

# **THYRISTORS & TRIACS**

**DATABOOK**

**1<sup>st</sup> EDITION**

**APRIL 1989**

## **USE IN LIFE SUPPORT MUST BE EXPRESSLY AUTHORIZED**

SGS-THOMSON' PRODUCTS ARE NOT AUTHORIZED FOR USE AS CRITICAL COMPONENTS IN LIFE SUPPORT DEVICES OR SYSTEMS WITHOUT THE EXPRESS WRITTEN APPROVAL OF THE PRESIDENT OF SGS-THOMSON Microelectronics. As used herein:

1. Life support devices to systems are devices or systems which, are intended for surgical implant into the body to support or sustain life, and whose failure to perform, when properly used in accordance with instructions for use provided in the labeling, can be reasonably expected to result in a significant injury to the user.
2. A critical component is any component of a life support device or system whose failure to perform can be reasonably expected to cause the failure of the life support device or system, or to affect its safety or effectiveness.



# TABLE OF CONTENTS

---

<b>ALPHANUMERICAL INDEX</b>	<b>Page</b>	<b>5</b>
-----------------------------	-------------	----------

---

<b>PRODUCT GUIDE</b>		<b>9</b>
SYMBOLS		<b>10</b>
UL HOMOLOGATION PRODUCTS		<b>11</b>
THYRISTOR SELECTION GUIDE		<b>12</b>
TRIAC SELECTION GUIDE		<b>15</b>
CROSS REFERENCE		<b>21</b>

---

<b>THYRISTOR DATASHEETS</b>		<b>35</b>
-----------------------------	--	-----------

---

<b>TRIAC DATASHEETS</b>		<b>197</b>
-------------------------	--	------------



# ALPHANUMERICAL INDEX

Type	Page
2N 681 .....	<b>37</b>
↓	
2N692 .....	<b>37</b>
2N 1770 .....	<b>43</b>
↓	
2N 1778 .....	<b>43</b>
2N 2619 .....	<b>43</b>
2N 3649 .....	<b>49</b>
↓	
2N 3653 .....	<b>49</b>
2N 3654 .....	<b>55</b>
↓	
2N 3658 .....	<b>55</b>
2N 5204 .....	<b>61</b>
↓	
2N 5207 .....	<b>61</b>
BTA 04-200 A .....	<b>307</b>
↓	
BTA 04-800 A .....	<b>307</b>
BTA 04-200 D .....	<b>311</b>
↓	
BTA 04-800 D .....	<b>311</b>
BTA 04-200 GP .....	<b>199</b>
↓	
BTA 04-600 GP .....	<b>199</b>
BTA 04-200 S .....	<b>315</b>
↓	
BTA 04-800 S .....	<b>315</b>
BTA 04-200 T .....	<b>319</b>
↓	
BTA 04-800 T .....	<b>319</b>
BTA 06-200 A .....	<b>323</b>
↓	
BTA 06-800 A .....	<b>323</b>
BTA 06-200 AW .....	<b>203</b>
↓	
BTA 06-800 AW .....	<b>203</b>
BTA 06-200 B .....	<b>327</b>
↓	
BTA 06-800 B .....	<b>327</b>
BTA 06-200 BW .....	<b>207</b>
↓	
BTA 06-800 BW .....	<b>207</b>

Type	Page
BTA 06-200 C .....	<b>331</b>
↓	
BTA 06-800 C .....	<b>331</b>
BTA 06-200 CW .....	<b>211</b>
↓	
BTA 06-800 CW .....	<b>211</b>
BTA 06-200 D .....	<b>335</b>
↓	
BTA 06-800 D .....	<b>335</b>
BTA 06-200 GP .....	<b>215</b>
↓	
BTA 06-600 GP .....	<b>215</b>
BTA 06-200 S .....	<b>339</b>
↓	
BTA 06-800 S .....	<b>339</b>
BTA 06-200 SW .....	<b>343</b>
↓	
BTA 06-800 SW .....	<b>343</b>
BTA 06-200 T .....	<b>349</b>
↓	
BTA 06-800 T .....	<b>349</b>
BTA 06-200 TW .....	<b>353</b>
↓	
BTA 06-800 TW .....	<b>353</b>
BTA 08-200 A .....	<b>359</b>
↓	
BTA 08-800 A .....	<b>359</b>
BTA 08-200 AW .....	<b>219</b>
↓	
BTA 08-800 AW .....	<b>219</b>
BTA 08-200 B .....	<b>363</b>
↓	
BTA 08-800 B .....	<b>363</b>
BTA 08-200 BW .....	<b>223</b>
↓	
BTA 08-800 BW .....	<b>223</b>
BTA 08-200 C .....	<b>367</b>
↓	
BTA 08-800 C .....	<b>367</b>
BTA 08-200 CW .....	<b>227</b>
↓	
BTA 08-800 CW .....	<b>227</b>

Type	Page
BTA 08-200 S .....	<b>371</b>
↓	
BTA 08-800 S .....	<b>371</b>
BTA 08-200 SW .....	<b>375</b>
↓	
BTA 08-800 SW .....	<b>375</b>
BTA 08-200 TW .....	<b>381</b>
↓	
BTA 08-800 TW .....	<b>381</b>
BTA 10-200 AW .....	<b>231</b>
↓	
BTA 10-800 AW .....	<b>231</b>
BTA 10-200 B .....	<b>387</b>
↓	
BTA 10-800 B .....	<b>387</b>
BTA 10-200 BW .....	<b>235</b>
↓	
BTA 10-800 BW .....	<b>235</b>
BTA 10-200 C .....	<b>391</b>
↓	
BTA 10-800 C .....	<b>391</b>
BTA 10-200 CW .....	<b>239</b>
↓	
BTA 10-800 CW .....	<b>239</b>
BTA 12-200 AW .....	<b>243</b>
↓	
BTA 12-800 AW .....	<b>243</b>
BTA 12-200 B .....	<b>395</b>
↓	
BTA 12-800 B .....	<b>395</b>
BTA 12-200 BW .....	<b>247</b>
↓	
BTA 12-800 BW .....	<b>247</b>
BTA 12-200 C .....	<b>399</b>
↓	
BTA 12-800 C .....	<b>399</b>
BTA 12-200 CW .....	<b>251</b>
↓	
BTA 12-800 CW .....	<b>251</b>
BTA 13-200 B .....	<b>255</b>
↓	
BTA 13-800 B .....	<b>255</b>

# ALPHANUMERICAL INDEX

Type	Page
BTA 16-200 AW ...	259
↓	
BTA 16-800 AW ...	259
BTA 16-200 B ...	263
↓	
BTA 16-800 B ...	263
BTA 16-200 BW ...	267
↓	
BTA 16-800 BW ...	267
BTA 16-200 CW ...	271
↓	
BTA 16-800 CW ...	271
BTA 25-200 A ...	275
↓	
BTA 25-800 A ...	275
BTA 25-200 B ...	279
↓	
BTA 25-800 B ...	279
BTA 26-200 A ...	283
↓	
BTA 26-800 A ...	283
BTA 26-200 B ...	287
↓	
BTA 26-800 B ...	287
BTA 40-200 A ...	291
↓	
BTA 40-800 A ...	291
BTA 40-200 B ...	295
↓	
BTA 40-800 B ...	295
BTA 41-200 A ...	299
↓	
BTA 41-800 A ...	299
BTA 41-200 B ...	303
↓	
BTA 41-800 B ...	303
BTB 04-200 A ...	307
↓	
BTB 04-800 A ...	307
BTB 04-200 D ...	311
↓	
BTB 04-800 D ...	311

Type	Page
BTB 04-200 S ...	315
↓	
BTB 04-800 S ...	315
BTB 04-200 T ...	319
↓	
BTB 04-800 T ...	319
BTB 06-200 A ...	323
↓	
BTB 06-800 A ...	323
BTB 06-200 AW ...	403
↓	
BTB 06-800 AW ...	403
BTB 06-200 B ...	327
↓	
BTB 06-800 B ...	327
BTB 06-200 BW ...	407
↓	
BTB 06-800 BW ...	407
BTB 06-200 C ...	331
↓	
BTB 06-800 C ...	331
BTB 06-200 CW ...	411
↓	
BTB 06-800 CW ...	411
BTB 06-200 D ...	335
↓	
BTB 06-800 D ...	335
BTB 06-200 S ...	339
↓	
BTB 06-800 S ...	339
BTB 06-200 SW ...	343
↓	
BTB 06-800 SW ...	343
BTB 06-200 T ...	349
↓	
BTB 06-800 T ...	349
BTB 06-200 TW ...	353
↓	
BTB 06-800 TW ...	353
BTB 08-200 A ...	359
↓	
BTB 08-800 A ...	359

Type	Page
BTB 08-200 AW ...	415
↓	
BTB 08-800 AW ...	415
BTB 08-200 B ...	363
↓	
BTB 08-800 B ...	363
BTB 08-200 BW ...	419
↓	
BTB 08-800 BW ...	419
BTB 08-200 C ...	367
↓	
BTB 08-800 C ...	367
BTB 08-200 CW ...	423
↓	
BTB 08-800 CW ...	423
BTB 08-200 S ...	371
↓	
BTB 08-800 S ...	371
BTB 08-200 SW ...	375
↓	
BTB 08-800 SW ...	375
BTB 08-200 TW ...	381
↓	
BTB 08-800 TW ...	381
BTB 10-200 AW ...	427
↓	
BTB 10-800 AW ...	427
BTB 10-200 B ...	387
↓	
BTB 10-800 B ...	387
BTB 10-200 BW ...	431
↓	
BTB 10-800 BW ...	431
BTB 10-200 C ...	391
↓	
BTB 10-800 C ...	391
BTB 10-200 CW ...	435
↓	
BTB 10-800 CW ...	435
BTB 12-200 AW ...	439
↓	
BTB 12-800 AW ...	439

# ALPHANUMERICAL INDEX

Type	Page
BTB 12-200 B	395
↓	
BTB 12-800 B	395
BTB 12-200 BW	443
↓	
BTB 12-800 BW	443
BTB 12-200 C	399
↓	
BTB 12-800 C	399
BTB 12-200 CW	447
↓	
BTB 12-800 CW	447
BTB 13-200 B	451
↓	
BTB 13-800 B	451
BTB 15-200 B	455
↓	
BTB 15-800 B	455
BTB 16-200 AW	459
↓	
BTB 16-800 AW	459
BTB 16-200B	463
↓	
BTB 16-800 B	463
BTB 16-200 BW	467
↓	
BTB 16-800 BW	467
BTB 16-200 CW	471
↓	
BTB 16-800 CW	471
BTB 24-200 B	475
↓	
BTB 24-800 B	475
BTB 26-200 A	479
↓	
BTB 26-800 A	479
BTB 26-200 B	483
↓	
BTB 26-800 B	483
BTB 41-200 A	487
↓	
BTB 41-800 A	487

Type	Page
BTB 41-200 B	491
↓	
BTB 41-800 B	491
BTW 30-600	67
↓	
BTW 30-1200	67
BTW 39-50	73
↓	
BTW 39-1200	73
BTW 48-200	79
↓	
BTW 48-1200	79
BTW 50-100	85
↓	
BTW 50-1200	85
BTW 66-200	91
↓	
BTW 66-1200	91
BTW 67-200	97
↓	
BTW 67-1200	97
BTW 68-200	103
↓	
BTW 68-1200	103
BTW 68-200N	109
↓	
BTW 68-1200 N	109
BTW 69-200	115
↓	
BTW 69-1200	115
BTW 69-200 N	121
↓	
BTW 69-1200 N	121
DB 3	495
DB 4	495
DC 34	499
DC 38	499
DC 42	499
TGAL 602	503
↓	
TGAL 610	503
TGDV 601	507
↓	
TGDV 612	507

Type	Page
TGF 148-600 B	125
↓	
TGF 148-1200 B	125
TGF 149-100 A	131
↓	
TGF 149-600 A	131
TL 1006	137
↓	
TL 8006	137
TLC 111 A	511
TLC 111 B	515
TLC 111 D	519
TLC 111 S	523
TLC 111 T	527
TLC 116 A	531
TLC 116 B	535
TLC 116 D	539
TLC 116 S	543
TLC 116 T	547
TLC 221 A	511
TLC 221 B	515
TLC 221 D	519
TLC 221 S	523
TLC 221 T	527
TLC 226 A	531
TLC 226 B	535
TLC 226 D	539
TLC 226 S	543
TLC 226 T	547
TLC 331 A	511
TLC 331 B	515
TLC 331 D	519
TLC 331 S	523
TLC 331 T	527
TLC 336 A	531
TLC 336 B	535
TLC 336 D	539
TLC 336 S	543
TLC 336 T	547
TLC 381 A	511
TLC 381 B	515
TLC 381 D	519
TLC 381 S	523
TLC 381 T	527
TLC 386 A	531
TLC 386 B	535
TLC 386 D	539
TLC 386 S	543
TLC 386 T	547

# ALPHANUMERICAL INDEX

Type	Page
TLS 106-05	141
↓	
TLS 106-6	141
TLS 107-05	141
↓	
TLS 107-6	141
TMMDB3	551
TODV 125	555
TODV 140	559
TODV 225	555
TODV 240	559
TODV 425	555
TODV 440	559
TODV 625	555
TODV 640	559
TODV 825	555
TODV 840	559
TODV 1025	555
TODV 1040	559
TODV 1225	555
TODV 1240	559
TPDV 125	563
TPDV 140	567
TPDV 225	563
TPDV 240	567
TPDV 425	563
TPDV 440	567
TPDV 625	563
TPDV 640	567
TPDV 825	563
TPDV 840	567
TPDV 1025	563
TPDV 1040	567
TPDV 1225	563
TPDV 1240	567
TRAL 1125 D	571
TRAL 1135 D	575
TRAL 2225 D	571
TRAL 2235 D	575
TRAL 3325 D	571
TRAL 3335 D	575
TRAL 3825 D	571
TRAL 3835 D	575
TSP 225	145
TSP 525	145
TSP 1025	145
TXDV 208	579
TXDV 212	583
TXDV 408	579
TXDV 412	583
TXDV 608	579
TXDV 612	583
TXDV 808	579

Type	Page
TXDV 812	583
TXN 054	151
TXN 056	155
TXN 058,G,K	159
TXN 0510	163
TXN 0512	167
TXN 104	151
TXN 106	155
TXN 108,G,K	159
TXN 110	163
TXN 112	167
TXN 204	151
TXN 206	155
TXN 208,G,K	159
TXN 210	163
TXN 212	167
TXN 404	151
TXN 406	155
TXN 408,G,K	159
TXN 410	163
TXN 412	167
TXN 604	151
TXN 606	155
TXN 608,G,K	159
TXN 610	163
TXN 612	167
TXN 804	151
TXN 806	155
TXN 808,G,K	159
TXN 810	163
TXN 812	167
TXN 1004	151
TXN 1006	155
TXN 1008,G,K	159
TXN 1010	163
TXN 1012	167
TYN 054	151
TYN 056	155
TYN 058,G,K	159
TYN 0510	163
TYN 0512	167
TYN 0516	171
TYN 104	151
TYN 106	155
TYN 108,G,K	159
TYN 110	163
TYN 112	167
TYN 116	171
TYN 204	151
TYN 206	155
TYN 208,G,K	159
TYN 210	163
TYN 212	167
TYN 216	171

Type	Page
TYN 225	179
TYN 404	151
TYN 406	155
TYN 408,G,K	159
TYN 410	163
TYN 412	167
TYN 416	171
TYN 425	179
TYN 604	151
TYN 606	155
TYN 608,G,K	159
TYN 610	163
TYN 612	167
TYN 616	171
TYN 625	179
TYN 682	175
TYN 683	175
TYN 685	175
TYN 688	175
TYN 690	175
TYN 692	175
TYN 804	151
TYN 806	155
TYN 808,G,K	159
TYN 810	163
TYN 812	167
TYN 816	171
TYN 825	179
TYN 1004	151
TYN 1006	155
TYN 1008,G,K	159
TYN 1010	163
TYN 1012	167
TYN 1025	179
TYN 1225	179
TYP 212	183
↓	
TYP 2012	183
TYS 406-05	189
↓	
TYS 406-8	189
TYS 407-05	189
↓	
TYS 407-8	189
TYS 606-05	193
↓	
TYS 606-8	193
TYS 607-05	193
↓	
TYS 607-8	193

# **PRODUCT GUIDE**

$di/dt$	Critical rate of rise of on-state current
$(di/dt)_c$	Critical rate of removal of the current of an alternistor
$dv/dt$	Critical rate of rise of off-state voltage
$(dv/dt)_c$	Critical rate of rise of commutating off-state voltage of a triac
$I_{DRM}$	Maximum forward leakage current
$I_{FGM}$	Peak forward gate current of a thyristor
$I_{GM}$	Peak gate current of a triac
$I_{GT}$	Gate trigger current
$I_H$	Continuous holding current
$I_L$	Latching current
$I_{RRM}$	Maximum reverse leakage current of a thyristor
$I_T (AV), I_O$	Mean on-state current of a thyristor
$I_{TM}$	Peak on-state current
$I_T(RMS)$	RMS on-state current
$I_{TSM}$	Non repetitive surge peak on-state current
$I^2t$	$I^2t$ for fusing
$P_G (AV)$	Mean gate power dissipation
$P_{GM}$	Peak gate power
$r_T$	Slope resistance
$R_{th} (c-h)$	Contract thermal resistance
$R_{th} (j-a)$	Junction to ambient thermal resistance
$R_{th} (j-c)$	Junction to case thermal resistance
$R_{th} (j-c) AC$	Junction to case thermal resistance for alternative current
$R_{th} (j-c) DC$	Junction to case thermal resistance for direct current
$R_{th} (j-l)$	Junction-leads thermal resistance
$T_{amb}$	Ambient temperature
$T_{case}, T_c$	Case temperature
$t_{gt}$	Turn-on time (total)
$T_j$	Junction temperature
$T_{lead}, T_L$	Lead temperature
$t_p$	Pulse width
$t_q$	Turn-off time of a thyristor
$T_{stg}$	Storage temperature
$V_{DRM}$	Repetitive peak off-state forward voltage
$V_{FGM}$	Peak forward gate voltage of a thyristor
$V_{GD}$	Gate non-trigger voltage
$V_{GM}$	Peak gate voltage of a triac
$V_{GT}$	Gate trigger voltage
$V_{RGM}$	Peak reverse gate voltage of a thyristor
$V_{RRM}$	Repetitive peak reverse voltage of a thyristor
$V_{TM}$	Peak on-state voltage
$V_{TO}$	Threshold voltage
$Z_{th}$	Thermal impedance

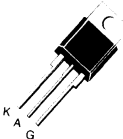
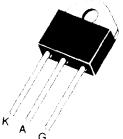
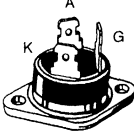

Case  Type	 <b>TO 220 AB</b>	 <b>TOP 3</b>	 <b>RD 91</b>
<b>THYRISTORS</b>	TXN 054 → 1004 TXN 056 → 1006 TXN 058 → 1008,G,K TXN 0510 → 1010 TXN 0512 → 1012	BTW 68-200 → 1200 BTW 69-200 → 1200	BTW 66-200 → 1200 BTW 67-200 → 1200
<b>TRIACS</b>	<b>Logic level triacs</b>		
	BTA 06-200 → 800 SW BTA 06-200 → 800 TW BTA 08-200 → 800 SW BTA 08-200 → 800 TW		
	<b>Snubberless triacs</b>		
	BTA 06-200 → 800 AW,BW,CW BTA 08-200 → 800 AW,BW,CW BTA 10-200 → 800 AW,BW,CW BTA 12-200 → 800 AW,BW,CW BTA 16-200 → 800 AW,BW,CW		
	<b>Sensitive gate triacs</b>		
	BTA 04-200 → 800 A,D,S,T BTA 06-200 → 800 A,D,S,T, BTA 08-200 → 800 A,S		
	<b>Standard triacs</b>		
	BTA 06-200 → 800 B,C BTA 08-200 → 800 B,C BTA 10-200 → 800 B,C BTA 12-200 → 800 B,C BTA 13-200 → 800 B BTA 16-200 → 800 B	BTA 26-200 → 800 A,B BTA 41-200 → 800 A,B	BTA 25-200 → 800 A,B BTA 40-200 → 800 A,B
	<b>Special triacs for light dimmers</b>		
	BTA 04-200 → 600 GP BTA 06-200 → 600 GP		
<b>Alternistors</b>			
TXDV 208 → 808 TXDV 212 → 812	TPDV 125 → 1225 TPDV 140 → 1240	TODV 125 → 1225 TODV 140 → 1240	

# THYRISTOR SELECTION GUIDE

## SENSITIVE GATE PLASTIC CASE THYRISTORS

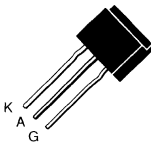
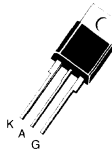
Case	 TL		 TO 220 AB				
	$I_T$ (RMS) (A)	4 (1)	4 (2)	4 (1)	4 (2)	6 (1)	6 (2)
$V_{RRM}$ (V)							
50	TLS 106-05	TLS 107-05	TYS 406-05	TYS 407-05	TYS 606-05	TYS 607-05	
100	TLS 106-1	TLS 107-1	TYS 406-1	TYS 407-1	TYS 606-1	TYS 607-1	
200	TLS 106-2	TLS 107-2	TYS 406-2	TYS 407-2	TYS 606-2	TYS 607-2	
400	TLS 106-4	TLS 107-4	TYS 406-4	TYS 407-4	TYS 606-4	TYS 607-4	
600	TLS 106-6	TLS 107-6	TYS 406-6	TYS 407-6	TYS 606-6	TYS 607-6	
800			TYS 406-8	TYS 407-8	TYS 606-8	TYS 607-8	

(1)  $I_{GT} = 0.2$  mA.

(2)  $I_{GT} = 0.5$  mA.

## STANDARD PLASTIC CASE THYRISTORS

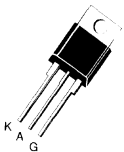
Case	 TL		 TO 220 AB							
	$I_T$ (RMS) (A)	3 (1)	4 (1) (4)	6 (1) (4)	8 (1) (4) (5)	10 (1) (4)	12 (1) (4)	16 (2)	25 (2)	25 (3)
$V_{RRM}$ (V)										
50			TYN 054	TYN 056	TYN 058	TYN 0510	TYN 0512	TYN 0516	TYN 682	
100	TL 1006		TYN 104	TYN 106	TYN 108	TYN 110	TYN 112	TYN 116	TYN 683	
200	TL 2006		TYN 204	TYN 206	TYN 208	TYN 210	TYN 212	TYN 216	TYN 685	
400	TL 4006		TYN 404	TYN 406	TYN 408	TYN 410	TYN 412	TYN 416	TYN 688	TYN 225
600	TL 6006		TYN 604	TYN 606	TYN 608	TYN 610	TYN 612	TYN 616	TYN 690	TYN 425
800	TL 8006		TYN 804	TYN 806	TYN 808	TYN 810	TYN 812	TYN 816	TYN 692	TYN 625
1000			TYN 1004	TYN 1006	TYN 1008	TYN 1010	TYN 1012			TYN 825
1200										TYN 1025

(1)  $I_{GTmax} = 15$  mA.

(2)  $I_{GTmax} = 25$  mA.

(3)  $I_{GTmax} = 40$  mA.

(4) Insulating version available

Ordering information TXN. Example: TXN 054

(5) With suffix G:  $I_{GTmax} = 25$  mA.

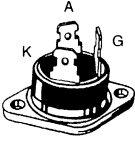
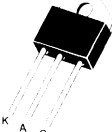
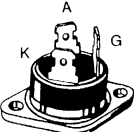
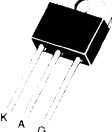

With suffix K:  $I_{GTmax} = 40$  mA.

STANDARD PLASTIC CASE THYRISTORS (Continued)

Case						
	RD 91	TOP 3	RD 91	TOP 3		
$I_T$ (RMS) (A)	30 (3)	30 (1) (3)	35 (1)	40 (3)	50 (2) (3)	55 (2)
$V_{RRM}$ (V)						
200	BTW 66- 200	BTW 68- 200	BTW 68- 200 N	BTW 67- 200	BTW 69- 200	BT W69- 200 N
400	BTW 66- 400	BTW 68- 400	BTW 68- 400 N	BTW 67- 400	BTW 69- 400	BTW 69- 400 N
600	BTW 66- 600	BTW 68- 600	BTW 68- 600 N	BTW 67- 600	BTW 69- 600	BTW 69- 600 N
800	BTW 66- 800	BTW 68- 800	BTW 68- 800 N	BTW 67- 800	BTW 69- 800	BTW 69- 800 N
1000	BTW 66-1000	BTW 68-1000	BTW 68-1000 N	BTW 67-1000	BTW 69-1000	BTW 69-1000 N
1200	BTW 66-1200	BTW 68-1200	BTW 68-1200 N	BTW 67-1200	BTW 69-1200	BTW 69-1200 N

(1)  $I_{GT}$  max = 50 A. (3) Insulated. Insulating voltage: 2500  $V_{RMS}$   
 (2)  $I_{GT}$  max = 80 A.

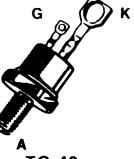
STANDARD METAL CASE THYRISTORS

Case						
	TO 64	TO 48	TO 65			
$I_T$ (RMS) (A)	7.4 (1)	25 (2)	25 (3)	35 (2)	50 (4)	63 (5)
$V_{RRM}$ (V)						
25	2N 1770		2N 681			
50	2N 1771	BTW 39- 50	2N 682			
100	2N 1772	BTW 30- 100	2N 683			BTW 50- 100
150	2N 1773					
200	2N 1774	BTW 39- 200	2N 685		BTW 48- 200	BTW 50- 200
250	2N 1775					
300	2N 1776	BTW 39- 300	2N 687			
400	2N 1777	BTW 39- 400	2N 688		BTW 48- 400	BTW 50- 400
500	2N 1778	BTW 39- 500	2N 689			
600	2N 2619	BTW 39- 600	2N 690	2N 5204	BTW 48- 600	BTW 50- 600
700		BTW 39- 700	2N 691			
800		BTW 39- 800	2N 692	2N 5205	BTW 48- 800	BTW 50- 800
900		BTW 39- 900				
1000		BTW 39-1000		2N 5206		BTW 50-1000
1100		BTW 39-1100				
1200		BTW 39-1200		2N 5207	BTW 48-1200	BTW 50-1200

(1)  $T_{case}$  = 90°C.  
 (2)  $T_{case}$  = 75°C.  
 (3)  $T_{case}$  = 70°C.  
 (4)  $T_{case}$  = 85°C.  
 (5)  $T_{case}$  = 105°C.

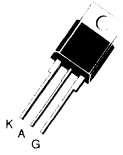
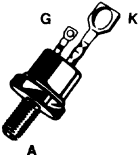

## OVERVOLTAGE PROTECTION THYRISTORS

Case	 TO 220 AB	 TO 48
$I_T$ (RMS) (A)	12 (1)	25 (2)
$V_{RRM}$ (V)		
25	TYP 212	TSP 225
50	TYP 512	TSP 525
100	TYP 1012	TSP 1025
200	TYP 2012	

(1)  $I_{TSM} = 750$  A (1 ms expo).

(2)  $I_{TSM} = 145$  A (250 ms  $\square$  )

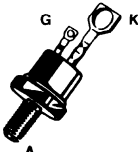
## FAST SWITCHING THYRISTORS

Case	 TO 48	 TO 65			
$I_T$ (RMS) (A)	25 (1)	35 (2)	35 (3)	63 (4)	63 (5)
$V_{RRM}$ (V)					
50		2N 3654	2N 3649	TGF 149-100 A	
100		2N 3655	2N 3650	TGF 149-200 A	
200		2N 3656	2N 3651	TGF 149-300 A	
300		2N 3657	2N 3652	TGF 149-400 A	
400		2N 3658	2N 3653	TGF 149-500 A	
500				TGF 149-600 A	
600	BTW 30- 600				TGF 148- 600 B
700					TGF 148- 800 B
800	BTW 30- 800				TGF 148- 800 B
900					TGF 148- 900 B
1000	BTW 30-1000				TGF 148-1000 B
1100					TGF 148-1100 B
1200	BTW 30-1200				TGF 148-1200 B

(1)  $V_{RRM} \leq 800$  V -  $t_q \leq 12$   $\mu$ s.  
 $V_{RRM} \geq 1000$  V -  $t_q \leq 20$   $\mu$ s.

(2)  $t_q \leq 15$   $\mu$ s.

(3)  $t_q \leq 10$   $\mu$ s.

(4)  $t_q \leq 20$   $\mu$ s.

(5)  $t_q \leq 40$   $\mu$ s.

**HIGH SWITCHING PERFORMANCE TRIACS**

Logic Level Triacs

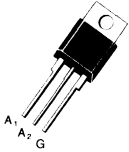
<b>Case</b>	 <p>TO 220 AB</p>	
$V_{RRM} \pm (V)$ / $I_T (RMS) (A)$	<b>6</b> (1) (2)	<b>8</b> (1) (2)
200 400 600 700 800	BTA 06-200 BTA 06-400 BTA 06-600 BTA 06-700 BTA 06-800	BTA 08-200 BTA 08-400 BTA 08-600 BTA 08-700 BTA 08-800

(1) With suffixes: TW, SW. (2) Non isolated type available. Designation BTB

Suffix	Quadrants		
	QI	QII	QIII
TW	5 mA	5 mA	5 mA
SW	10 mA	10 mA	10 mA

Snubberless Triacs

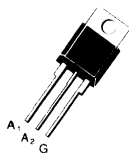
<b>Case</b>	 <p>TO 220 AB</p>				
$V_{DRM} \pm (V)$ / $I_T (RMS) (A)$	<b>6</b> (1) (2)	<b>8</b> (1) (2)	<b>10</b> (1) (2)	<b>12</b> (1) (2)	<b>16</b> (1) (2)
200 400 600 700 800	BTA 06-200 BTA 06-400 BTA 06-600 BTA 06-700 BTA 06-800	BTA 08-200 BTA 08-400 BTA 08-600 BTA 08-700 BTA 08-800	BTA 10-200 BTA 10-400 BTA 10-600 BTA 10-700 BTA 10-800	BTA 12-200 BTA 12-400 BTA 12-600 BTA 12-700 BTA 12-800	BTA 16-200 BTA 16-400 BTA 16-600 BTA 16-700 BTA 16-800

(1) With suffixes: AW, BW, CW. (2) Non isolated type available. Designation BTB.

Suffix	Quadrants		
	QI	QII	QIII
AW	75 mA	75 mA	75 mA
BW	50 mA	50 mA	50 mA
CW	35 mA	35 mA	35 mA

# TRIAC SELECTION GUIDE

## SENSITIVE GATE TRIACS

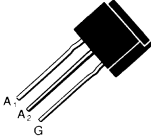
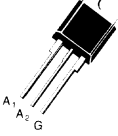
Case	 TL		 TO 220 AB		
$I_T$ (RMS) (A)	1 (1)	3 (1)	4 (1) (3)	6 (1) (3)	8 (2) (3)
$V_{DRM}$ $\pm$ (V)					
200	TLC 111	TLC 116	BTA 04-200	BTA 06-200	BTA 08-200
400	TLC 221	TLC 226	BTA 04-400	BTA 06-400	BTA 08-400
600	TLC 331	TLC 336	BTA 04-600	BTA 06-600	BTA 08-600
700	TLC 381	TLC 386	BTA 04-700	BTA 06-700	BTA 08-700
800			BTA 04-800	BTA 06-800	BTA 08-800

(1) With suffixes: T, S, D, A.

(2) With suffixes: S, A.

(3) Non isolated type available. Designation BTB....

Suffix	Quadrants			
	QI	QII	QIII	QIV
T	5 mA	5 mA	5 mA	5 mA
S	10 mA	10 mA	10 mA	10 mA
D	5 mA	5 mA	5 mA	10 mA
A	10 mA	10 mA	10 mA	25 mA

STANDARD PLASTIC CASE TRIACS

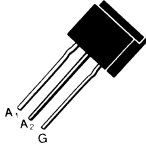
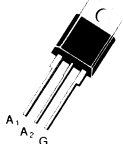
Case	 TL		 TO 220 AB									
	$I_T$ (RMS) (A)	$V_{DRM}$ $\pm$ (V)	1 (1)	3 (1)	6 (2) (3)	8 (2) (3)	10 (2) (3)	12 (2) (3)	12 (1) (3)	15 (1)	16 (1) (3)	25 (1)
200	TLC 111	TLC 116	BTA 06-200	BTA 08-200	BTA 10-200	BTA 12-200	BTA 13-200	BTB 15-200	BTA 16-200	BTB 24-200		
400	TLC 221	TLC 226	BTA 06-400	BTA 08-400	BTA 10-400	BTA 12-400	BTA 13-400	BTB 15-400	BTA 16-400	BTB 24-400		
600	TLC 331	TLC 336	BTA 06-600	BTA 08-600	BTA 10-600	BTA 12-600	BTA 13-600	BTB 15-600	BTA 16-600	BTB 24-600		
700	TLC 381	TLC 386	BTA 06-700	BTA 08-700	BTA 10-700	BTA 12-700	BTA 13-700	BTB 15-700	BTA 16-700	BTB 24-700		
800			BTA 06-800	BTA 08-800	BTA 10-800	BTA 12-800	BTA 13-800	BTB 15-800	BTA 16-800	BTB 24-800		

- (1) With suffix: B
- (2) With suffixes: B,C
- (3) Non isolated type available. Designation BTB...

Suffix	Quadrants			
	QI	QII	QIII	QIV
B	50 mA	50 mA	50 mA	100 mA
C	25 mA	25 mA	25 mA	50 mA

STANDARD PLASTIC CASE TRIACS

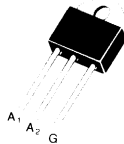
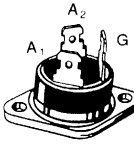
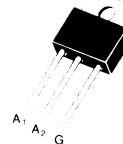

Case	 TOP 3		 RD 91		 TOP 3		
	$I_T$ (RMS) (A)	$V_{DRM}$ $\pm$ (V)	25 (1)	30	30 (1)	40	40 (1)
200	BTA 26-200 B, A	BTB 26-200 B, A	BTA 25-200 B, A	BTA 40-200 B, A	BTA 41-200 B, A	BTB 41-200 B, A	
400	BTA 26-400 B, A	BTB 26-400 B, A	BTA 25-400 B, A	BTA 40-400 B, A	BTA 41-400 B, A	BTB 41-400 B, A	
600	BTA 26-600 B, A	BTB 26-600 B, A	BTA 25-600 B, A	BTA 40-600 B, A	BTA 41-600 B, A	BTB 41-600 B, A	
700	BTA 26-700 B, A	BTB 26-700 B, A	BTA 25-700 B, A	BTA 40-700 B, A	BTA 41-700 B, A	BTB 41-700 B, A	
800	BTA 26-800 B, A	BTB 26-800 B, A	BTA 25-800 B, A	BTA 40-800 B, A	BTA 41-800 B, A	BTB 41-800 B, A	

Suffix B: Quadrants QI QII QIII:  $I_{GT}$  = 50 mA. Suffix A: Quadrants QI QII QIII:  $I_{GT}$  = 100 mA.  
 QIV :  $I_{GT}$  = 100 mA. QIV :  $I_{GT}$  = 150 mA.

(1) Insulated case - Insulating voltage 2500  $V_{RMS}$ .

# TRIAC SELECTION GUIDE

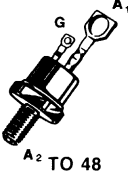
## STANDARD METAL CASE TRIACS

Case			
$I_T$ (RMS) (A)	25 (1)	35 (2)	60 (2)
$V_{DRM}$ (V)			
200	TRAL 1125 D	TRAL 1135 D	TGAL 602
400	TRAL 2225 D	TRAL 2235 D	TGAL 604
600	TRAL 3325 D	TRAL 3335 D	TGAL 606
700	TRAL 3825 D	TRAL 3835 D	
800			TGAL 608
1000			TGAL 610

(1) Quadrants QI QII QIII:  $I_{GT} = 100$  mA  
 QIV :  $I_{GT} = 150$  mA.

(2) Quadrants QI QIII :  $I_{GT} = 100$  mA  
 QII QIV:  $I_{GT} = 150$  mA.

## SPECIAL TRIACS FOR LIGHT DIMMERS

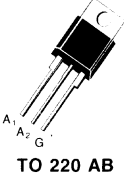



Case		
$I_T$ (RMS) (A)	4 (1)	6 (1)
$V_{DRM}$ (V)		
200	BTA 04-200 GP	BTA 06-200 GP
400	BTA 04-400 GP	BTA 06-400 GP
600	BTA 04-600 GP	BTA 06-600 GP

(1) Quadrants QI QII QIII:  $I_{GT} = 50$  mA.  
 QIV :  $I_{GT} = 75$  mA.

Insulated case - Insulating voltage 2500  $V_{RMS}$

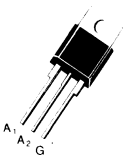
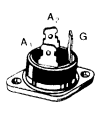



ALTERNISTOR

Case							
	TO 220 AB	RD 91	TOP 3	RD 91	TOP 3	TO 65	
$I_T$ (RMS) (A)	8	12	25	25	40	60	
$V_{DRM}$ $\pm$ (V)	(1) (4)	(1) (4)	(2) (4)	(2) (4)	(3) (4)	(3) (4)	
100			TODV 125	TPDV 125	TODV 140	TPDV 140	TGDV 601
200	TXDV 208	TXDV 212	TODV 225	TPDV 225	TODV 240	TPDV 240	TGDV 602
400	TXDV 408	TXDV 412	TODV 425	TPDV 425	TODV 440	TPDV 440	TGDV 604
600	TXDV 608	TXDV 612	TODV 625	TPDV 625	TODV 640	TPDV 640	TGDV 606
800	TXDV 808	TXDV 812	TODV 825	TPDV 825	TODV 840	TPDV 840	TGDV 608
1000			TODV 1025	TPDV 1025	TODV 1040	TPDV 1040	TGDV 610
1200			TODV 1225	TPDV 1225	TODV 1240	TPDV 1240	TGDV 612

- (1) Quadrants QI - QII - QIII:  $I_{GT} = 100$  mA
- (2) Quadrants QI - QII - QIII:  $I_{GT} = 150$  mA
- (3) Quadrants QI - QII - QIII:  $I_{GT} = 200$  mA
- (4) Insulated Case - Insulating voltage 2500  $V_{RMS}$

TRIGGER DIODES (DIACS)

Case				
Min	Breakover voltage Typ	Max	Types	
28	32	36	DB 3	TMMDB3
35	40	45	DB 4	
30	34	38	DC 34	
35	38	42	DC 38	
39	42	45	DC 42	



CROSS REFERENCE

INDUSTRY PART N.	SGS-THOMSON DIRECT REPLACEMENT	SGS-THOMSON SIMILAR REPLACEMENT	INDUSTRY PART N.	SGS-THOMSON DIRECT REPLACEMENT	SGS-THOMSON SIMILAR REPLACEMENT
2N3899		2N5204	2N6401	TYN116	
2N4169		2N1772	2N6402	TYN216	
2N4170		2N1775	2N6403	TYN416	
2N4172		2N1777	2N6404	TYN616	
2N4174		2N2619	2N6405	TYN816	
2N5204	2N5204		2N6504	TYN225	
2N5206	2N5206		2N6505	TYN225	
2N5207	2N5207		2N6506	TYN225	
2N6070		TLC116C	2N6507	TYN425	
2N6070A		TLC116D	2N6508	TYN625	
2N6070B		TLC116D	2N6509	TYN825	
2N6071		TLC116C	BR100/03	DB3	
2N6071A		TLC116D	BT136F500		BTA06-600C
2N6071B		TLC116T	BT136F500D		BTA04-600D
2N6072		TLC226C	BT136F500E		BTA04-600S
2N6072A		TLC226D	BT136F500F		BTA06-600C
2N6072B		TLC226T	BT136F600		BTA06-600C
2N6073		TLC226A	BT136F600E		BTA04-600S
2N6073A		TLC226D	BT136F600F		BTA06-600C
2N6073B		TLC226T	BT136-500	BTB06-600C	
2N6074		TLC336A	BT136-500E	BTB04-600S	
2N6074A		TLC336D	BT136-500F	BTB06-600C	
2N6074B		TLC336T	BT136-500G	BTB06-600B	
2N6075		TLC336A	BT136-600	BTB06-600C	
2N6075A		TLC336D	BT136-600E	BTB04-600S	
2N6077B		TLC336T	BT136-600F	BTB06-600C	
2N6236		TLS106-05	BT136-600G	BTB06-600B	
2N6237		TLS106-2	BT136-800	BTB06-700C	
2N6238		TLS106-1	BT136-800E	BTB04-800S	
2N6239		TLS106-1	BT136-800F	BTB06-800C	
2N6240		TLS106-4	BT136-800G	BTB06-800B	
2N6241		TLS106-6	BT137F500D		BTA08-600TW
2N6342	BTB08-200B		BT137F500E		BTA08-600S
2N6342A	BTB12-200B		BT137F500F		BTA08-600C
2N6343	BTB08-400B		BT137F500G		BTA08-600C
2N6343A	BTB12-400B		BT137F600		BTA08-600C
2N6344	BTB08-600B		BT137F600E		BTA08-600S
2N6344A	BTB12-600B		BT137F600F		BTA08-600C
2N6345	BTB08-800B		BT137F600G		BTA08-600B
2N6345A	BTB12-800B		BT137-500	BTB08-600C	
2N6346	BTB08-200B		BT137-500D		BTB08-600TW
2N6346A	BTB12-200B		BT137-500F	BTB08-600C	
2N6347	BTB08-400B		BT137-500G	BTB08-600B	
2N6347A	BTB12-400B		BT137-600	BTB08-600C	
2N6348	BTB08-600B		BT137-600F	BTB08-600C	
2N6348A	BTB12-600B		BT137-600G	BTB08-600B	
2N6349	BTB08-800B		BT137-800	BTB08-800C	
2N6349A	BTB12-800B		BT137-800F	BTB08-800C	
2N6394	TYN0512		BT137-800G	BTB08-800B	
2N6395	TYN112		BT137F500		BTA08-600C
2N6396	TYN212		BT138F500		BTA12-600C
2N6397	TYN412		BT138F500F		BTA12-600C
2N6398	TYN612		BT138F500G		BTA12-600C
2N6399	TYN812		BT138F600		BTA12-600C
2N6400	TYN0516		BT138F600F		BTA12-600C

# CROSS REFERENCE

INDUSTRY PART N.	SGS-THOMSON DIRECT REPLACEMENT	SGS-THOMSON SIMILAR REPLACEMENT	INDUSTRY PART N.	SGS-THOMSON DIRECT REPLACEMENT	SGS-THOMSON SIMILAR REPLACEMENT
BT138F600G		BTA12-600C	BTW45-800R	2N5205	
BT138-500	BTB12-600C		BTY91-400R		BTW39-400
BT138-500F	BTB12-600C		BTY91-500R		BTW39-600
BT138-500G	BTB12-600C		BTY91-600R		BTW39-600
BT138-600	BTB12-600C		BTY91-800R		BTW39-800
BT138-600F	BTB12-600C		C106A		TLS106-1
BT138-600G	BTB12-600C		C106A1		TLS106-1
BT139F500		BTA16-600CW	C106B		TLS106-2
BT139F500F		BTA16-600CW	C106B1		TLS106-2
BT139F500G		BTA16-600B	C106C		TLS106-4
BT139F600		BTA16-600CW	C106C1		TLS106-4
BT139F600F		BTA16-600CW	C106D		TLS106-4
BT139F600G		BTA16-600B	C106D1		TLS106-4
BT139-500		BTB16-600CW	C106E		TLS106-6
BT139-500F		BTB16-600CW	C106E1		TLS106-6
BT139-500G	BTB16-600B		C106F1		TLS106-05
BT139-600		BTB16-600CW	C106M		TLS106-6
BT139-600F		BTB16-600CW	C106M1		TLS106-6
BT139-600G	BTB16-600B		C106Y1		TLS106-05
BT139-800		BTB16-800CW	C107A		TLS107-1
BT139-800F		BTB16-800CW	C107A1		TLS107-1
BT139-800G	BTB16-800B		C107B		TLS107-2
BT150	TYS406-6		C107B1		TLS107-2
BT151F500		TXN610	C107C		TLS107-4
BT151F650		TXN810	C107C1		TLS107-4
BT151F800		TXN810	C107D		TLS107-4
BT151-500R	TYN610		C107D1		TLS107-4
BT151-650R	TYN810		C107E		TLS107-6
BT151-800R	TYN810		C107E1		TLS107-6
BT152-400R	TYN688		C107F1		TLS107-05
BT152-600R	TYN690		C107M		TLS107-6
BT158-400	BTB08-400C		C107M1		TLS107-6
BT158-600	BTB08-600C		C107Y1		TLS107-6
BTA140-500	BTB24-600B		C122A	TYN108G	
BTA140-600	BTB24-600B		C122A1	TYN108G	
BTA21C	BTB08-400C		C122B	TYN208G	
BTA21D	BTB08-400C		C122B1	TYN208G	
BTA21E	BTB08-600C		C122C	TYN408G	
BTA22B	BTB10-200C		C122C1	TYN408G	
BTA22C	BTB10-400C		C122D	TYN408G	
BTA22D	BTB10-400C		C122D1	TYN408G	
BTA22E	BTB10-600C		C122E	TYN608G	
BTA22M	BTB10-700C		C122E1	TYN608G	
BTA23B	BTB12-200C		C122F1	TYN058G	
BTA23C	BTB12-400C		C122M	TYN608G	
BTA23D	BTB12-400C		C122M1	TYN608G	
BTA23E	BTB12-600C		C122N1	TYN808	
BTA23M	BTB12-600C		C122S1	TYN808	
BTW40-400R	BTW48-400		C205A		TLS106-1
BTW40-600R	BTW48-600		C205B		TLS106-2
BTW40-800R	BTW48-800		C205C		TLS106-4
BTW45-1000R	2N5206		C205D		TLS106-4
BTW45-1200R	2N5207		C205Y		TLS106-05
BTW45-400R	2N5204		C205YY		TLS106-05
BTW45-600R	2N5204		C228A		2N5204

## CROSS REFERENCE

INDUSTRY PART N.	SGS-THOMSON DIRECT REPLACEMENT	SGS-THOMSON SIMILAR REPLACEMENT	INDUSTRY PART N.	SGS-THOMSON DIRECT REPLACEMENT	SGS-THOMSON SIMILAR REPLACEMENT
C228B		2N5204	IT115A	BTA16-200B	
C228C		2N5204	IT115B	BTA16-200B	
C228D		2N5204	IT115HA	BTA16-200C	
C228E		2N5204	IT115HX	BTA16-200C	
C228F		2N5204	IT16	BTA06-200B	
C228M		2N5204	IT16A	BTA06-200B	
C35A		2N5204	IT16B	BTA06-200B	
C35B		2N5204	IT16HA	BTA06-200C	
C35C		2N5204	IT16HX	BTA06-200C	
C35D		2N5204	IT18	BTA08-200B	
C35E		2N5204	IT18A	BTA08-200B	
C35F		2N5204	IT18B	BTA08-200B	
C35M		2N5204	IT18HA	BTA08-200C	
C35N		2N5205	IT18HX	BTA08-200C	
C35S		2N5205	IT210	BTA10-200B	
D0201YR		DB3	IT210A	BTA10-200B	
EC103A		TLS106-1	IT210B	BTA10-200B	
EC103A3		TLS107-1	IT210HA	BTA10-200C	
EC103B		TLS106-2	IT210HX	BTA10-200C	
EC103B3		TLS107-2	IT215	BTA16-200B	
EC103C		TLS106-4	IT215A	BTA16-200B	
EC103C3		TLS107-4	IT215B	BTA16-200B	
EC103D		TLS106-4	IT215HA	BTA16-200C	
EC103D3		TLS107-4	IT215HX	BTA16-200C	
EC103E		TLS106-6	IT26	BTA06-200B	
EC103E3		TLS107-6	IT26A	BTA06-200B	
EC103M		TLS106-6	IT26B	BTA06-200B	
EC103M3		TLS107-6	IT26HA	BTA06-200C	
EC103Y		TLS106-05	IT26HX	BTA06-200C	
EC103Y3		TLS107-05	IT28	BTA08-200B	
HT32	DB3		IT28A	BTA08-200B	
HT35	DC34		IT28B	BTA08-200B	
HT40	DC38		IT28HA	BTA08-200C	
IT010	BTA10-200B		IT28HX	BTA08-200C	
IT010B	BTA10-200B		IT310	BTA10-400B	
IT015	BTA16-200C		IT310A	BTA10-400B	
IT015	BTA16-200B		IT310B	BTA10-400B	
IT06	BTA06-200B		IT310HA	BTA10-400C	
IT06A	BTA06-200B		IT310HX	BTA10-400C	
IT06B	BTA06-200B		IT315	BTA16-400B	
IT06HA	BTA06-200C		IT315A	BTA16-400B	
IT06HX	BTA06-200C		IT315B	BTA16-400B	
IT08	BTA08-200B		IT315HA	BTA16-400C	
IT08A	BTA08-200B		IT315HX	BTA16-400C	
IT08B	BTA08-200B		IT36	BTA06-400B	
IT08HA	BTA08-200C		IT36A	BTA06-400B	
IT08HX	BTA08-200C		IT36B	BTA06-400B	
IT1010HA	BTA10-200C		IT36HA	BTA06-400C	
IT1010HX	BTA10-200C		IT36HX	BTA06-400C	
IT110	BTA10-200B		IT38	BTA08-400B	
IT110A	BTA10-200B		IT38A	BTA08-400B	
IT110B	BTA10-200B		IT38B	BTA08-400B	
IT110HA	BTA10-200C		IT38HA	BTA08-400C	
IT110HX	BTA10-200C		IT38HX	BTA08-400C	
IT115	BTA16-200B		IT410	BTA10-400B	

# CROSS REFERENCE

INDUSTRY PART N.	SGS-THOMSON DIRECT REPLACEMENT	SGS-THOMSON SIMILAR REPLACEMENT	INDUSTRY PART N.	SGS-THOMSON DIRECT REPLACEMENT	SGS-THOMSON SIMILAR REPLACEMENT
IT410A	BTA10-400B		IT68A	BTA08-600B	
IT410B	BTA10-400B		IT68B	BTA08-600B	
IT410HA	BTA10-400C		IT68HA	BTA08-600C	
IT410HX	BTA10-400C		IT68HX	BTA08-600C	
IT415	BTA16-400B		L2004F31		BTB04-200T
IT415A	BTA16-400B		L2004F51		BTB04-200T
IT415B	BTA16-400B		L2004F71		BTB04-200S
IT415HA	BTA16-400C		L2004F91		BTB04-200A
IT415HX	BTA16-400C		L2004L3	BTA04-200T	
IT46	BTA06-400B		L2004L5	BTA04-200T	
IT46A	BTA06-400B		L2004L7	BTA04-200S	
IT46B	BTA06-400B		L2004L9	BTA04-200A	
IT46HA	BTA06-400C		L2006L6	BTA06-200T	
IT46HX	BTA06-400C		L2006L7	BTA06-200S	
IT48	BTA08-400B		L2006L9	BTA06-200A	
IT48A	BTA08-400B		L2008L6	BTA08-200T	
IT48B	BTA08-400B		L2008L7	BTA08-200S	
IT48HA	BTA08-400C		L2008L9	BTA08-200A	
IT48HX	BTA08-400C		L201E3		TLC111T
IT510	BTA10-600B		L201E5		TLC111T
IT510A	BTA10-600B		L201E7		TLC111S
IT510B	BTA10-600B		L201E9		TLC111A
IT510HA	BTA10-600C		L4004F31		BTB04-400T
IT510HX	BTA10-600C		L4004F51		BTB04-400T
IT515	BTA16-600B		L4004F71		BTB04-400S
IT515A	BTA16-600B		L4004F91		BTB04-400A
IT515B	BTA16-600B		L4004L3	BTA04-400T	
IT515HA	BTA16-600C		L4004L5	BTA04-600T	
IT515HX	BTA16-600C		L4004L7	BTA04-400S	
IT56	BTA06-600B		L4004L9	BTA04-400A	
IT56A	BTA06-600B		L4006L6	BTA06-400T	
IT56B	BTA06-600B		L4006L7	BTA06-400S	
IT56HA	BTA06-600C		L4006L9	BTA06-400A	
IT56HX	BTA06-600C		L4008L6	BTA08-400T	
IT58	BTA08-600B		L4008L7	BTA08-440S	
IT58A	BTA08-600B		L4008L9	BTA08-400A	
IT58B	BTA08-600B		L401E3		TLC221T
IT58HA	BTA08-600C		L401E5		TLC221T
IT58HX	BTA08-600C		L401E7		TLC221S
IT610	BTA10-600B		L401E9		TLC221A
IT610A	BTA10-600B		M4013NN	BTW48-800	
IT610B	BTA10-600B		M4013PN	BTW48-1200	
IT610HA	BTA10-600C		M4013VN	BTW48-1200	
IT610HX	BTA10-600C		MAC15A10	BTB16-800B	
IT615	BTA16-600B		MAC15A10FP		BTA16-800B
IT615A	BTA16-600B		MAC15A4	BTB16-200B	
IT615B	BTA16-600B		MAC15A4FP		BTA16-200B
IT615HA	BTA16-600C		MAC15A5	BTB16-400B	
IT615HX	BTA16-600C		MAC15A5FP		BTA16-400B
IT66	BTA06-600B		MAC15A6	BTB16-400B	
IT66A	BTA06-600B		MAC15A6FP		BTA16-400B
IT66B	BTA06-600B		MAC15A7	BTB16-600B	
IT66HA	BTA06-600C		MAC15A7FP		BTA16-600B
IT66HX	BTA06-600C		MAC15A8	BTB16-600B	
IT68	BTA08-600B		MAC15A8FP		BTA16-600B

**CROSS REFERENCE**

INDUSTRY PART N.	SGS-THOMSON DIRECT REPLACEMENT	SGS-THOMSON SIMILAR REPLACEMENT	INDUSTRY PART N.	SGS-THOMSON DIRECT REPLACEMENT	SGS-THOMSON SIMILAR REPLACEMENT
MAC15A9	BTB16-700B	BTA16-700B	MAC222A7	BTB08-600C	
MAC15A9FP			MAC222-1		
MAC20A10			MAC222-10		
MAC20A4			MAC222-2		
MAC20A5			MAC222-3		
MAC20A6			MAC222-4		
MAC20A7			MAC222-5		
MAC20A8			MAC222-6		
MAC20A9			MAC222-7		
MAC210A10			BTB10-800C		
MAC210A10FP	BTB10-200C	BTA10-200C	MAC223A4		BTA24-200B
MAC210A4			MAC223A5		BTB24-400B
MAC210A4FP	BTB10-400C	BTA10-400C	MAC223A6		BTA24-400B
MAC210A5			MAC223A7		BTA24-600B
MAC210A5FP	BTB10-400C	BTA10-400C	MAC223A8		BTA24-600B
MAC210A6			MAC223A9		BTA24-700B
MAC210A6FP	BTB10-600C	BTA10-400C	MAC224A10		BTB41-800B
MAC210A7			MAC224A4		BTB41-200B
MAC210A7FP	BTB10-600C	BTA10-600C	MAC224A5		BTB41-400B
MAC210A8			MAC224A6		BTB41-400B
MAC210A8FP	BTB10-700C	BTA10-600C	MAC224A7		BTB41-600B
MAC210A9			MAC224A8		BTB41-600B
MAC210A9FP	BTB12-800C	BTA10-700C	MAC224A9		BTB41-700B
MAC212A10			MAC228A10	BTB08-800S	
MAC212A10FP	BTB12-200C	BTA12-800C	MAC228A4	BTB08-200S	
MAC212A4			MAC228A5	BTB08-400S	
MAC212A4FP	BTB12-400C	BTA12-200C	MAC228A6	BTB08-400S	
MAC212A6			MAC228A7	BTB08-600S	
MAC212A6FP	BTB12-600C	BTA12-400C	MAC228A8	BTB08-600S	
MAC212A8			MAC228A9	BTB08-700S	
MAC212A8FP	BTB08-800C	BTA12-600C	MAC228-10	BTB08-800S	
MAC218A10			MAC228-4	BTB08-200S	
MAC218A10FP	BTB08-200C	BTA08-800C	MAC228-5	BTB08-400S	
MAC218A4			MAC228-6	BTB08-400S	
MAC218A4FP	BTB08-400C	BTA08-200C	MAC228-7	BTB08-600S	
MAC218A6			MAC228-8	BTB08-600D	
MAC218A6FP	BTB08-400C	BTA08-400C	MAC228-9	BTB08-700S	
MAC218A8			MAC25A10		
MAC218A8FP	BTB08-200C	BTA08-400C	MAC25A4		BTA26-200B
MAC220-2			MAC25A5		
MAC220-3	BTB08-200C		MAC25A6		BTA26-400B
MAC220-5	BTB08-400C		MAC25A7		BTA26-600B
MAC220-7	BTB08-600C		MAC25A8		BTA26-600B
MAC220-9	BTB08-700B		MAC25A9		BTA26-700B
MAC221-3	BTB08-200C		MAC3010-15	BTB15-400B	
MAC221-5	BTB08-400C		MAC3010-25	BTB24-400B	
MAC221-7	BTB08-600C		MAC3010-4		BTB04-400A
MAC221-9	BTB08-700B		MAC3010-40		BTB40-400B
MAC222A1	BTB08-200C		MAC3010-401		BTA41-400B
MAC222A10	BTB08-700B		MAC3010-8	BTB08-400C	
MAC222A2	BTB08-200C		MAC3020-15	BTB15-400B	
MAC222A3	BTB08-200C		MAC3020-25	BTB24-400B	
MAC222A4	BTB08-200C		MAC3020-4		BTB04-400A
MAC222A5	BTB08-400C		MAC3020-40		BTB40-400B
MAC222A6	BTB08-400C		MAC3020-401		BTA41-400B

# CROSS REFERENCE

INDUSTRY PART N.	SGS-THOMSON DIRECT REPLACEMENT	SGS-THOMSON SIMILAR REPLACEMENT	INDUSTRY PART N.	SGS-THOMSON DIRECT REPLACEMENT	SGS-THOMSON SIMILAR REPLACEMENT
MAC3020-8	BTB08-400C		MCR100-6		TLS106-4
MAC3030-15	BTB15-400B		MCR100-7		TLS106-6
MAC3030-25	BTB24-400B		MCR100-8		TLS106-6
MAC3030-4		BTB04-400A	MCR102		TLS106-05
MAC3030-40		BTB40-400B	MCR103		TLS106-05
MAC3030-401		BTB41-400B	MCR106-1		TLS106-05
MAC3030-8	BTB08-400C		MCR106-3		TLS106-1
MAC3040-15	BTB15-400B		MCR106-4		TLS106-2
MAC3040-25	BTB24-400B		MCR106-6		TLS106-4
MAC3040-4		BTB06-400C	MCR106-8		TLS106-6
MAC3040-40		BTB40-400B	MCR218-10	TYN808G	
MAC3040-401		BTA41-400B	MCR218-2	TYN058G	
MAC3040-8	BTB08-400B		MCR218-3	TYN108G	
MAC3060-15	BTB16-600B		MCR218-4	TYN208G	
MAC3060-25	BTB24-600B		MCR218-5	TYN408G	
MAC3060-4		BTB04-400B	MCR218-6	TYN408G	
MAC3060-40		BTB41-600B	MCR218-7	TYN608G	
MAC3060-401		BTA41-600B	MCR218-8	TYN608G	
MAC3060-8	BTB08-600B		MCR218-9	TYN808G	
MAC320A10	BTB24-800B		MRC220-5	TYN412	
MAC320A10FP		BTA26-800B	MCR220-7	TYN612	
MAC320A4	BTB24-200B		MCR220-9	TYN812	
MAC320A4FP		BTA26-200B	MCR221-5	TYN416	
MAC320A6	BTB24-400B		MCR221-7	TYN616	
MAC320A6FP		BTA26-400B	MCR221-9	TYN816	
MAC320A8	BTB24-600B		MCR225-12	TYN1225	
MAC320A8FP		BTA26-600B	MCR225-5	TYN425	
MAC50A10		BTA40-800B	MCR225-7	TYN625	
MAC50A4		BTA40-200B	MCR225-9	TYN825	
MAC50A5		BTA40-400B	MCR22-2		TLS106-05
MAC50A6		BTA40-400B	MCR22-3		TLS106-1
MAC50A7		BTA40-600B	MCR22-4		TLS106-2
MAC50A8		BTA40-600B	MCR22-5		TLS106-4
MAC50A9		BTA40-700B	MCR22-6		TLS106-4
MAC97A3		TLC111D	MCR22-7		TLS106-6
MAC97A4		TLC111D	MCR22-8		TLS106-6
MAC97A5		TLC221D	MCR641	BTW48-200	
MAC97A6		TLC221D	MCR6410	BTW48-800	
MAC97A7		TLC331D	MCR642	BTW48-200	
MAC97A8		TLC331D	MCR643	BTW48-200	
MAC97B3		TLC111T	MCR644	BTW48-200	
MAC97B4		TLC111T	MCR645	BTW48-400	
MAC97B5		TLC221T	MCR646	BTW48-400	
MAC97B6		TLC221T	MCR647	BTW48-600	
MAC97B7		TLC331T	MCR648	BTW48-600	
MAC97B8		TLC331T	MCR649	BTW48-800	
MAC97-3		TLC111S	MCR68-1	TYN0512	
MAC97-4		TLC111S	MCR68-2	TYN0512	
MAC97-5		TLC221S	MCR68-3	TYN112	
MAC97-6		TLC221S	MCR68-6	TYN412	
MAC97-7		TLC331S	Q2001L3		TLC116A
MAC97-8		TLC331S	Q2001L4		TLC116B
MCR100-3		TLS106-1	Q2003L3		TLC116A
MCR100-4		TLS106-2	Q2003L4		TLC116B
MCR100-5		TLS106-4	Q2004F31		TLC116A



INDUSTRY PART N.	SGS-THOMSON DIRECT REPLACEMENT	SGS-THOMSON SIMILAR REPLACEMENT	INDUSTRY PART N.	SGS-THOMSON DIRECT REPLACEMENT	SGS-THOMSON SIMILAR REPLACEMENT
Q2004F41		TLC116B	Q401E4		TLC221B
Q2004L3	BTA04-200A		Q4025J6		BTA26-400B
Q2004L4	BTA04-200A		Q4025L5		BTA26-400B
Q2006F41		BTB06-200C	Q4025P		BTA25-400B
Q2006L4	BTA06-200C		Q4025R5	BTB24-400B	
Q2006L5	BTA06-200B		Q4040J7		BTA41-400A
Q2006R4	BTB06-200C		Q4040P		BTA40-400B
Q2008F41		BTA08-200C	Q4040W7		BTB41-400A
Q2008L4	BTA08-200C		Q5004F41		BTB04-600C
Q2008L4A	BTA08-200C		Q5004L4	BTA06-600C	
Q2008L5	BTA08-200B		Q5006F41		BTB06-600C
Q2008R4	BTB08-200C		Q5006L3	BTA06-600C	
Q2010F41		BTA10-200C	Q5006L5	BTA06-600B	
Q2010L4	BTA10-200C		Q5006R4	BTB06-600C	
Q2010L5	BTA10-200B		Q5008F41		BTB08-600C
Q2010R4	BTB10-200C		Q5008L4	BTA08-600C	
Q2012L5	BTA12-200B		Q5008L4A	BTA08-600C	
Q2012R5	BTB12-200B		Q5008L5	BTA08-600B	
Q2015L5	BTA16-200B		Q5008R4	BTA08-600C	
Q2015R5	BTB15-200B		Q5010L4	BTA10-600C	
Q201E3		TLC111A	Q5010L5	BTA10-600B	
Q201E4		TLC111B	Q5010R4	BTB10-600C	
Q2025J6		BTA26-200B	Q5012L5	BTA12-600B	
Q2025L5		BTA26-200B	Q5012R5	BTB12-600B	
Q2025P		BTA25-200B	Q5015L5	BTA16-600B	
Q2025R5	BTB24-200B		Q5015R5	BTB16-600B	
Q2025W6		BTB26-200B	Q5025J6	BTA26-600B	
Q2040J7		BTA41-200A	Q5025L6		BTA26-600B
Q2040P		BTA40-200B	Q5025P		BTA25-600B
Q2040W7		BTB41-200A	Q5025R5	BTB24-600B	
Q4001L3		TLC226A	Q5025W6		BTB26-600B
Q4001L4		TLC226B	Q5040J7		BTA41-600A
Q4003L3		TLC226A	Q5040P		BTA40-600B
Q4003L4		TLC226A	Q5040W7		BTB41-600A
Q4004F31		BTB04-400A	Q6004F41		BTB04-600C
Q4004F41		BTB04-400A	Q6004L4	BTA06-600C	
Q4004L3	BTA04-400A		Q6006F51		BTB06-600B
Q4004L4	BTA04-400A		Q6006L5	BTA06-600B	
Q4006F41		BTB06-400C	Q6006R5	BTB06-600B	
Q4006L4	BTA06-400C		Q6008F51		BTB08-600B
Q4006L5	BTA06-400B		Q6008L5	BTA08-600B	
Q4006R4	BTB06-400C		Q6008L5A	BTA08-600B	
Q4008F41		BTB08-400C	Q6008R5	BTB08-600B	
Q4008L4A	BTA08-400C		Q6010F41		BTB10-600C
Q4008L5	BTA08-400B		Q6010F51		BTB10-600B
Q4008R4	BTB08-400C		Q6010L5	BTA10-600B	
Q4010F41		BTB10-400C	Q6010R5	BTB10-600B	
Q4010L4	BTA10-400C		Q6012L5	BTA12-600B	
Q4010L5	BTA10-400B		Q6012R5	BTB12-600B	
Q4010R4	BTB10-400C		Q6015L5	BTA16-600B	
Q4012L5	BTA12-400B		Q6015R5	BTB15-600B	
Q4012R5	BTB12-400B		Q6025J6		BTA26-600B
Q4015L5	BTA15-400B		Q6025L6		BTA26-600B
Q4015R5	BTB15-400B		Q6025P		BTA25-600B
Q401E3		TLC221A	Q6025R5	BTB24-600B	

**CROSS REFERENCE**

INDUSTRY PART N.	SGS-THOMSON DIRECT REPLACEMENT	SGS-THOMSON SIMILAR REPLACEMENT	INDUSTRY PART N.	SGS-THOMSON DIRECT REPLACEMENT	SGS-THOMSON SIMILAR REPLACEMENT
Q6025W6		BTB26-600B	S0535W	BTW69-200N	
Q6040J7		BTA41-600A	S0602BH	TYS606-2	
Q6040P		BTA40-600B	S0602DH	TYS606-4	
Q6040W7		BTB41-600A	S0602MH	TYS606-6	
Q8004L4	BTA06-700C		S0602NH	TYS606-8	
Q8010L5	BTA10-700B		S0605BH	TYS407-2	
Q8010R5	BTB10-700B		S0605DH	TYS407-4	
Q8012L5	BTA12-700B		S0605MH	TYS407-6	
Q8012R5	BTB12-700B		S0605NH	TYS407-8	
Q8015L5	BTA16-700B		S0610BH	TYN206	
Q8025R5	BTB24-700B		S0610DH	TYN406	
S0105L		TYN116	S0610MH	TYN606	
S0301LS1		TLS106-05	S0610NH	TYN806	
S0301LS2		TLS107-05	S0810BH	TYN208	
S0303LS1		TLS106-05	S0810DH	TYN408	
S0303LS2		TLS107-05	S0810MH	TYN608	
S0304F1		TYN054	S0810NH	TYN808	
S0306F1		TYN056	S1001LS1		TL5106-1
S0306FS21		TYS606-05	S1001LS2		TL5107-1
S0306FS31		TYS607-05	S1001LS3		TL5107-6
S0306L	TXN056		S1003L		TXN104
S0308F1		TYN058	S1003LS1		TL5106-1
S0308L	TXN058		S1003LS2		TL5107-1
S0308R	TYN058		S1003LS3		TL5107-1
S0310F1		TYN0510	S1004F1		TYN104
S0310L	TXN0510		S1006F1		TYN106
S0312L	TXN0512		S1006FS21		TYS606-1
S0312R	TYN0512		S1006FS31		TYS607-1
S0316R	TYN0516		S1006L	TXN106	
S031E		TL1006	S1008F1		TYN108
S0325R	TYN682		S1008L	TXN108	
S0335J	BTW69-200		S1008R	TYN108	
S0335W	BTW69-200N		S1010BH	TYN210	
S0501LS1		TL5106-05	S1010DH	TYN410	
S0501LS2		TL5107-05	S1010F1		TYN110
S0503LS1		TL5106-05	S1010L	TXN110	
S0503LS2		TL5107-05	S1010MH	TYN610	
S0504F1		TYN054	S1010NH	TYN810	
S0506F1		TYN056	S1012L	TXN112	
S0506FS21		TYS606-05	S1012R	TYN112	
S0506FS31		TYS607-05	S1016R	TYN1016	
S0506L	TXN056		S101E		TL1006
S0508F1		TYN058	S1020L		TYN683
S0508FS21		TYS806-05	S1025R	TYN683	
S0508FS31		TYS807-05	S1035J	BTW69-200	
S0508L	TXN058		S1035W	BTW69-200N	
S0508R	TYN058		S1210BH	TYN212	
S0510F1		TYN0510	S1210DH	TYN412	
S0510L	TXN0510		S1210MH	TYN612	
S0512L	TXN0512		S1210NH	TYN812	
S0512R	TYN0512		S112A		TYN108
S0516R	TYN0516		S112B		TYN208
S051E		TL1006	S112C		TYN408
S0525R	TYN225		S122D		TYN408
S0535J	BTW69-200		S112F		TYN608

INDUSTRY PART N.	SGS-THOMSON DIRECT REPLACEMENT	SGS-THOMSON SIMILAR REPLACEMENT	INDUSTRY PART N.	SGS-THOMSON DIRECT REPLACEMENT	SGS-THOMSON SIMILAR REPLACEMENT
S122F		TYN058	S2514BK		BTW66-200
S122M		TYN608	S2514DH		TYN688
S122S		TYN808	S2514DK		BTW66-400
S1610BH	TYN216		S2514MH		TYN690
S1610DH	TYN416		S2514MK		BTW66-600
S1610MH	TYN616		S2514NK		BTW66-800
S1610NH	TYN816		S2800A		TYN108
S2001LS1		TLS106-1	S2800B		TYN208
S2001LS2		TLS106-2	S2800C		TYN408
S2001LS3		TLS107-2	S2800D		TYN408
S2003LS1		TLS106-1	S2800E		TYN608
S2003LS2		TLS106-2	S2800F		TYN058
S2003LS3		TLS107-2	S2800M		TYN608
S2004F1		TYN204	S2800N		TYN808
S2006F1		TYN206	S2800S		TYN808
S2006FS21		TYS606-2	S4001LS1		TLS106-4
S2006FS31		TYS607-2	S4001LS2		TLS106-4
S2006L	TXN206		S4001LS3		TLS106-4
S2008F1		TYN208	S4003L		TXN404
S2008L	TXN208		S4003LS1		TLS106-4
S2008R	TYN208		S4003LS2		TLS106-4
S20010F1		TYN210	S4003LS3		TLS107-4
S2010L		TXN210	S4004F1		TYN404
S2012F1		TYN212	S4006F1		TYN406
S2012L		TXN212	S4006FS21		TYS606-4
S2012R		TYN212	S4006FS31		TYS607-4
S2016R		TYN216	S4006L	TXN406	
S201E		TL2006	S4008F1		TYN408
S2020L		TYN685	S4008FS21		TYS806-4
S2025R	TYN685		S4008FS31		TYS807-4
S2035J	BTW69-200		S4008L	TXN408	
S2035W	BTW69-200N		S4008R	TYN408	
S2060A		TYS406-1	S4010F1		TYN410
S2060B		TYS406-2	S4010L	TXN410	
S2060C		TYS406-4	S4012F1		TYN412
S2060D		TYS406-4	S4012L	TXN412	
S2060E		TYS406-6	S4012R	TYN412	
S2060F		TYS406-05	S4015L		TYN416
S2060M		TYS406-6	S4016R	TYN416	
S2060Y		TYS406-05	S401E		TL4006
S2061		TYS407-05	S4020L		TYN688
S2061A		TYS407-1	S4025R	TYN688	
S2061B		TYS407-2	S4035J	BTW69-400	
S2061C		TYS407-4	S4035W	BTW69-400N	
S2061D		TYS407-4	S6003L		TXN604
S2061E		TYS407-6	S6004F1		TYN604
S2061M		TYS407-6	S6006F1		TXN606
S2512BH		TYN685	S6006L	TXN606	
S2512BK		BTW66-200	S6008F1		TXN608
S2512DH		TYN688	S6008L	TXN608	
S2512DK		BTW66-400	S6008R	TYN608	
S2512MH		TYN690	S6010F1		TXN610
S2512MK		BTW66-600	S6010L	TXN610	
S2512NK		BTW66-800	S6012L	TXN612	
S2514BH		TYN685	S6012R	TYN612	



CROSS REFERENCE

INDUSTRY PART N.	SGS-THOMSON DIRECT REPLACEMENT	SGS-THOMSON SIMILAR REPLACEMENT	INDUSTRY PART N.	SGS-THOMSON DIRECT REPLACEMENT	SGS-THOMSON SIMILAR REPLACEMENT
S0410BH	TYN204		T2512DK		BTA25-400B
S0410DH	TYN404		T2512MH	BTB24-600B	
S0410MH	TYN604		T2512MK		BTA25-600B
S0410NH	TYN804		T2512NH	BTB24-700B	
T106A1		TLS106-1	T2513BH	BTB24-200B	
T106B1		TLS106-2	T2513BK		BTA25-200A
T106C1		TLS106-4	T2513DH	BTB24-400B	
T106D1		TLS106-4	T2513DK		BTA25-400A
T106E1		TLS106-6	T2513MH	BTB24-600B	
T106F1		TLS106-05	T2513MK		BTA25-600A
T106M1		TLS106-6	T2513NH	BTB24-700B	
T106Q1		TLS106-05	T2800A	BTB08-200C	
T106Y1		TLS106-05	T2800B	BTB08-200C	
T107A1		TLS107-1	T2800C	BTB08-400C	
T107B1		TLS107-2	T2800D	BTB08-400B	
T107C1		TLS107-4	T2800E	BTB08-600B	
T107D1		TLS107-4	T2800F	BTB08-200C	
T107E1		TLS107-6	T2800M	BTB08-600C	
T107F1		TLS107-05	T2801A	BTB06-200B	
T107M1		TLS107-6	T2801B	BTB06-200B	
T107Q1		TLS107-05	T2801C	BTB06-400B	
T107Y1		TLS107-05	T2801D	BTB06-400C	
T2322A		TLC116S	T2801E	BTB06-600C	
T2322B		TLC116S	T2801F	BTB06-200C	
T2322C		TLC226S	T2801M	BTB06-600B	
T2322D		TLC226S	T2801N	BTB06-700B	
T2322E		TLC336S	T2801S	BTB06-700B	
T2322M		TLC336S	T2802B	BTB08-200B	
T2323A		TLC116C	T2802C	BTB08-400B	
T2323B		TLC116C	T2802D	BTB08-400B	
T2323C		TLC226C	T2802E	BTB08-600B	
T2323D		TLC226C	T2802F	BTB08-200C	
T2323E		TLC336C	T2802M	BTB08-600B	
T2323M		TLC336C	T2850A		BTA08-200C
T2500A	BTB06-200C		T2850B		BTA08-200C
T2500AFP		BTA06-200C	T2850D		BTA08-400C
T2500B	BTB06-200C		T2850E		BTA08-600C
T2500BFP		BTA06-200C	T2850M		BTA08-600C
T2500C	BTB06-400C		T4012BK		BTA40-200B
T2500CFP		BTA06-400C	T4012DK		BTA40-400B
T2500D	BTB06-400C		T4012MK		BTA40-600B
T2500DFP		BTA06-400C	T4013BK		BTA40-200A
T2500E	BTB06-600C		T4013DK		BTA40-400A
T2500EFP		BTA06-600C	T4013MK		BTA40-600A
T2500M	BTB06-600C		T6000B		BTB16-200B
T2500MFP		BTA06-600C	T6000C		BTB16-400B
T2500N	BTB06-700C		T6000D		BTB16-400B
T2500NFP		BTA06-700C	T6000E		BTB16-600B
T2500S	BTB06-700C		T6000M		BTB16-600B
T2500SFP		BTA06-700C	T6001B		BTB16-200B
T2506B	BTB06-200C		T6001C		BTB16-400B
T2506D	BTB06-400C		T6001D		BTB16-400B
T2512BH	BTB24-200B		T6001E		BTB16-600B
T2512BK		BTA25-200B	T6001M		BTB16-600B
T2512DH	BTB24-400B		TAG220-200	BTB06-200C	

**CROSS REFERENCE**

INDUSTRY PART N.	SGS-THOMSON DIRECT REPLACEMENT	SGS-THOMSON SIMILAR REPLACEMENT	INDUSTRY PART N.	SGS-THOMSON DIRECT REPLACEMENT	SGS-THOMSON SIMILAR REPLACEMENT
TAG220-400	BTB06-400C		TAG252-700	BTB10-700C	
TAG220-600	BTB06-600C		TAG255-200	BTB12-200B	
TAG220-700	BTB06-700C		TAG255-400	BTB12-400B	
TAG221-200	BTB06-200S		TAG255-600	BTB12-600B	
TAG221-400	BTB06-400S		TAG255-700	BTB12-700B	
TAG221-600	BTB06-600S		TAG255-800	BTB12-800B	
TAG221-700	BTB06-700S		TAG256-200	BTB12-200B	
TAG222-200	BTB06-200D		TAG256-400	BTB12-400B	
TAG222-400	BTB06-400D		TAG256-600	BTB12-600B	
TAG222-600	BTB06-600D		TAG256-700	BTB12-700B	
TAG222-700	BTB06-700D		TAG256-800	BTB12-800B	
TAG224-200	BTB08-200C		TAG257-200	BTB12-200C	
TAG224-400	BTB08-400C		TAG257-400	BTB12-400C	
TAG224-600	BTB08-600C		TAG257-600	BTB12-600C	
TAG224-700	BTB08-700C		TAG257-800	BTB12-800C	
TAG225-200	BTB08-200C		TAG265-200	BTB12-200B	
TAG225-400	BTB08-400C		TAG265-400	BTB12-400B	
TAG225-600	BTB08-600C		TAG265-600	BTB12-600B	
TAG225-700	BTB08-700C		TAG265-800	BTB12-800B	
TAG226-200	BTB08-200S		TAG266-200	BTB12-200C	
TAG226-400	BTB08-400S		TAG266-400	BTB12-400C	
TAG226-600	BTB08-600S		TAG266-600	BTB12-600C	
TAG226-700	BTB08-700C		TAG266-800	BTB12-700C	
TAG227-200	BTB08-200S		TAG280-200	BTB16-200B	
TAG227-400	BTB08-400S		TAG280-400	BTB16-400B	
TAG227-600	BTB08-600S		TAG280-600	BTB16-600B	
TAG230-200	BTB04-200C		TAG280-700	BTB16-700B	
TAG230-400	BTB04-400C		TAG280-800	BTB16-800B	
TAG230-600	BTB04-600C		TAG281-200	BTB16-200B	
TAG230-700	BTB04-700C		TAG281-400	BTB16-400B	
TAG230-800	BTB04-800C		TAG281-600	BTB16-600B	
TAG231-200	BTB06-200C		TAG281-700	BTB16-700B	
TAG231-400	BTB06-400C		TAG281-800	BTB16-800B	
TAG231-600	BTB06-600C		TAG420-200	BTA06-200B	
TAG232-200	BTB06-200S		TAG420-400	BTA06-400B	
TAG232-400	BTB06-400S		TAG420-600	BTA06-700B	
TAG232-600	BTB06-600S		TAG420-700	BTA06-700B	
TAG232-700	BTB06-700S		TAG421-200	BTA06-200C	
TAG233-200	BTB06-200T		TAG421-400	BTA06-400C	
TAG233-400	BTB06-400T		TAG421-600	BTA06-600C	
TAG233-600	BTB06-600T		TAG425-200	BTA08-200B	
TAG233-700	BTB06-700T		TAG425-400	BTA08-400B	
TAG250-200	BTB10-200C		TAG425-600	BTA08-600B	
TAG250-400	BTB10-600C		TAG425-700	BTA08-700B	
TAG250-600	BTB10-600C		TAG426-200	BTA08-200C	
TAG250-700	BTB10-700C		TAG426-400	BTA08-400C	
TAG250-800	BTB10-800C		TAG426-600	BTA08-600C	
TAG251-200	BTB10-200C		TAG451-200	BTA08-200C	
TAG251-400	BTB10-400C		TAG451-400	BTA08-400C	
TAG251-600	BTB10-600C		TAG451-600	BTA08-600C	
TAG251-700	BTB10-700C		TAG452-200	BTA08-200A	
TAG251-800	BTB10-800C		TAG452-400	BTA08-400A	
TAG252-200	BTB10-200C		TAG452-600	BTA08-600A	
TAG252-400	BTB10-400C		TAG456-200	BTA10-200C	
TAG252-600	BTB10-600C		TAG456-400	BTA10-400C	

CROSS REFERENCE

INDUSTRY PART N.	SGS-THOMSON DIRECT REPLACEMENT	SGS-THOMSON SIMILAR REPLACEMENT	INDUSTRY PART N.	SGS-THOMSON DIRECT REPLACEMENT	SGS-THOMSON SIMILAR REPLACEMENT
TAG456-600	BTA10-600C		TAG627-100		TYN108
TAG457-200	BTA10-200C		TAG627-200		TYN208
TAG457-400	BTA10-400C		TAG627-400		TYN408
TAG457-600	BTA10-600C		TAG627-600		TYN608
TAG480-200	BTA12-200B		TAG627-700		TYN808
TAG480-400	BTA12-400B		TAG627-800		TYN808
TAG480-600	BTA12-600B		TAG630-100	TYN104	
TAG480-700	BTA12-700B		TAG630-200	TYN204	
TAG481-200	BTA12-200C		TAG630-400	TYN404	
TAG481-400	BTA12-400C		TAG630-600	TYN604	
TAG481-600	BTA12-600C		TAG630-700	TYN804	
TAG481-700	BTA12-700C		TAG630-800	TYN804	
TAG481-800	BTA12-800C		TAG631-100	TYN104	
TAG510B	TYN204		TAG631-200	TYN204	
TAG510D	TYN404		TAG631-400	TYN404	
TAG510M	TYN604		TAG631-600	TYN604	
TAG511B	TYN204		TAG631-700	TYN804	
TAG511D	TYN404		TAG631-800	TYN804	
TAG511M	TYN604		TAG632-100		TYN104
TAG512B	TYN204		TAG632-200		TYN204
TAG512D	TYN404		TAG632-400		TYN404
TAG512M	TYN604		TAG632-600		TYN604
TAG620-100	TYN106		TAG633-200	TYN804	
TAG620-200	TYN206		TAG633-400	TYS406-2	
TAG620-400	TYN406		TAG633-600	TYS406-4	
TAG620-600	TYN606		TAG633-700	TYS406-6	
TAG620-700	TYN806		TAG633-800	TYS406-8	
TAG620-800	TYN806		TAG660-100	TYN110	
TAG621-100	TYN106		TAG660-200	TYN210	
TAG621-200	TYN206		TAG660-400	TYN408	
TAG621-400	TYN406		TAG660-700	TYN810	
TAG621-600	TYN606		TAG660-800	TYN810	
TAG621-700	TYN806		TAG661-100	TYN110	
TAG621-800	TYN806		TAG661-200	TYN210	
TAG622-100		TYN106	TAG661-400	TYN410	
TAG622-200		TYN206	TAG661-600	TYN610	
TAG622-400		TYN406	TAG661-700	TYN810	
TAG622-600		TYN606	TAG661-800	TYN810	
TAG623-200	TYN806		TAG662-100		TYN110
TAG623-400	TYS606-2		TAG662-200		TYN210
TAG623-600	TYS606-4		TAG662-400		TYN410
TAG623-800	TYS606-6		TAG662-600		TYN610
TAG625-100	TYS606-8		TAG665-100	TYN112	
TAG625-200	TYN108G		TAG665-200	TYN212	
TAG625-400	TYN208G		TAG665-400	TYN412	
TAG625-600	TYN408G		TAG665-600	TYN612	
TAG625-700	TYN608G		TAG665-700	TYN812	
TAG625-800	TYN808G		TAG665-800	TYN812	
TAG626-100	TYN808G		TAG666-100	TYN112	
TAG626-200	TYN108		TAG666-200	TYN212	
TAG626-400	TYN208		TAG666-400	TYN412	
TAG626-600	TYN408		TAG666-600	TYN612	
TAG626-700	TYN608		TAG666-700	TYN812	
TAG626-800	TYN808		TAG666-800	TYN812	
			TAG667-100		TYN112

# CROSS REFERENCE

INDUSTRY PART N.	SGS-THOMSON DIRECT REPLACEMENT	SGS-THOMSON SIMILAR REPLACEMENT	INDUSTRY PART N.	SGS-THOMSON DIRECT REPLACEMENT	SGS-THOMSON SIMILAR REPLACEMENT
TAG667-200		TYN212	TIC126S		TYN812
TAG667-400		TYN412	TIC201A		TLC116D
TAG667-600		TYN612	TIC201B		TLC116D
TAG670-200	TYN208K		TIC201C		TLC226D
TAG675-200	TYN212K		TIC201D		TLC226D
TAG675-400	TYN412K		TIC201E		TLC336D
TAG675-600	TYN612K		TIC201M		TLC336D
TAG676-200	TYN212K		TIC201S		TLC386D
TAG676-400	TYN412K		TIC206A		BTB04-200D
TAG676-600	TYN612K		TIC206B		BTB04-200D
TAG680-100	TYN616		TIC206C		BTB04-400D
TAG680-200	TYN116		TIC206D		BTB04-400D
TAG680-400	TYN216		TIC206E		BTB04-600D
TAG680-600	TYN416		TIC206M		BTB04-700D
TAG680-700	TYN816		TIC206M		BTB04-600D
TAG680-800	TYN816		TIC216A	BTA06-200C	
TAG96-100		TLC116B	TIC216B	BTA06-200C	
TAG96-200		TLC216B	TIC216D	BTA06-400C	
TAG96-400		TLC416B	TIC225A		BTB08-200S
TAG96-500		TLC616B	TIC225B		BTB08-200S
TAG96-600		TLC616B	TIC225C		BTB08-400S
TIC106A		YS606-1	TIC225D		BTB08-400S
TIC106B		YS606-2	TIC225E		BTB08-600S
TIC106C		YS606-4	TIC225M		BTB08-600S
TIC106D		YS606-4	TIC225S		BTB08-400S
TIC106E		YS606-6	TIC226A		BTB08-200B
TIC106M		YS606-6	TIC226B		BTB08-200B
TIC108A		YS607-1	TIC226C		BTB08-400B
TIC108B		YS607-2	TIC226D		BTB08-400B
TIC108C		YS607-4	TIC226E		BTB08-600B
TIC108D		YS607-4	TIC226M		BTB08-600B
TIC108E		YS607-6	TIC226S		BTB08-700B
TIC108M		YS607-6	TIC236B	BTB12-200BW	
TIC116A	TYN108		TIC236D	BTB12-400BW	
TIC116B	TYN208		TIC236E	BTB12-600BW	
TIC116C		TYN408	TIC236M	BTB12-600BW	
TIC116D	TYN408		TIC236S	BTB12-700BW	
TIC116E		TYN608	TIC246A	BTB16-200BW	
TIC116F	TYN608		TIC246B	BTA16-200BW	
TIC116M	TYN608		TIC246C	BTB16-400BW	
TIC116N		TYN808	TIC246D	BTA16-400BW	
TIC116S		TYN808	TIC246E	BTA16-600BW	
TIC116Y	TYN058		TIC246M	BTA16-600BW	
TIC122A	TYN108		TIC246S	BTB16-700BW	
TIC122B	TYN208		TIC253A		BTB26-200B
TIC122D	TYN408		TIC253B	BTB24-200B	
TIC122F	TYN608		TIC253C		BTB26-400B
TIC122M	TYN608		TIC253D		BTB26-400B
TIC126A	TYN112		TIC253E		BTB26-600B
TIC126B	TYN212		TIC253M		BTB26-600B
TIC126C		TYN412	TIC263A		BTB26-200B
TIC126D	TYN412		TIC263B		BTB26-200B
TIC126E		TYN612	TIC263C		BTB26-400B
TIC126F	TYN610		TIC263D		BTB26-400B
TIC126M	TYN610		TIC263E		BTB26-600B
TIC126N		TYN812	TIC263M		BTB26-600B
			TIC336A		BTB12-200BW



# **THYRISTOR DATASHEETS**



**THYRISTORS**

- GLASS PASSIVATED CHIP
- HIGH STABILITY AND RELIABILITY

Thread : 1/4" -28 UNF : type N"  
 M6 on request : type N" + suffix M



**TO 48**  
(Metal)

**DESCRIPTION**

General purpose SCR suited for power supplies up to 400 Hz on resistive or inductive loads.

**ABSOLUTE RATINGS** (limiting values)

Symbol	Parameter		Value	Unit
$I_{T(RMS)}$	RMS on-state Current (1)	$T_c = 70\text{ }^\circ\text{C}$	25	A
$I_{T(AV)}$	Mean on-state Current (1)	$T_c = 70\text{ }^\circ\text{C}$	16	A
$I_{TSM}$	Non Repetitive Surge Peak on-state Current ( $T_j$ initial $\leq 125\text{ }^\circ\text{C}$ ) (2)	$t = 8.3\text{ ms}$	210	A
		$t = 10\text{ ms}$	200	
$I^2t$	$I^2t$ Value for Fusing	$t = 10\text{ ms}$	200	$\text{A}^2\text{s}$
di/dt	Critical Rate of Rise of on-state Current (3)		100	A/ $\mu\text{s}$
$T_{stg}$ $T_j$	Storage and Operating Junction Temperature Range		- 65 to 150 - 65 to 125	$^\circ\text{C}$ $^\circ\text{C}$

Symbol	Parameter	2N681	2N682	2N683	2N685	2N687	2N688	2N689	2N690	2N691	2N692	Unit
$V_{DRM}$ $V_{RRM}$	Repetitive Peak off-state Voltage (4)	25	50	100	200	300	400	500	600	700	800	V

(1) Single phase circuit, 180° conduction angle.

(2) Half sine wave.

(3)  $I_G = 0.4\text{ A}$   $di_G/dt = 1\text{ A}/\mu\text{s}$ .

(4)  $T_j = 125\text{ }^\circ\text{C}$ .

**THERMAL RESISTANCES**

Symbol	Parameter	Value	Unit
$R_{th(j-c)}$	Junction-case for D.C.	1.7	$^\circ\text{C}/\text{W}$
$R_{th(c-h)}$	Contact (case to heatsink)	0.4	$^\circ\text{C}/\text{W}$

**GATE CHARACTERISTICS** (maximum values)

$P_{GM} = 5\text{ W}$  ( $t_p = 100\ \mu\text{s}$ )       $I_{FGM} = 2\text{ A}$  ( $t_p = 100\ \mu\text{s}$ )       $V_{RGM} = 5\text{ V}$   
 $P_{G(AV)} = 1\text{ W}$        $V_{FGM} = 10\text{ V}$  ( $t_p = 100\ \mu\text{s}$ )

**ELECTRICAL CHARACTERISTICS**

Symbol	Test Conditions			Min.	Typ.	Max.	Unit
$I_{GT}$	$T_j = 25\text{ }^\circ\text{C}$ Pulse Duration > 20 $\mu\text{s}$	$V_D = 12\text{ V}$	$R_L = 33\ \Omega$		30	40	mA
$V_{GT}$	$T_j = 25\text{ }^\circ\text{C}$ Pulse Duration > 20 $\mu\text{s}$	$V_D = 12\text{ V}$	$R_L = 33\ \Omega$			1.5	V
$V_{GD}$	$T_j = 125\text{ }^\circ\text{C}$	$V_D = V_{DRM}$	$R_L = 3.3\text{ k}\Omega$	0.25			V
$I_H$	$T_j = 25\text{ }^\circ\text{C}$	$I_T = 0.5\text{ A}$	Gate Open		20		mA
$I_L$	$T_j = 25\text{ }^\circ\text{C}$ Pulse Duration > 20 $\mu\text{s}$	$V_D = 12\text{ V}$	$I_G = 80\text{ mA}$		40		mA
$V_{TM}$	$T_j = 25\text{ }^\circ\text{C}$	$I_{TM} = 50\text{ A}$	$t_p = 10\text{ ms}$			2	V
$I_{DRM}$	$V_{DRM}$ Specified			$T_j = 25\text{ }^\circ\text{C}$		0.02	mA
				$T_j = 125\text{ }^\circ\text{C}$		3	
$I_{RRM}$	$V_{RRM}$ Specified			$T_j = 25\text{ }^\circ\text{C}$		0.02	mA
				$T_j = 125\text{ }^\circ\text{C}$		3	
$t_{gt}$	$T_j = 25\text{ }^\circ\text{C}$ $I_G = 200\text{ mA}$	$V_D = V_{DRM}$ $di_G/dt = 2\text{ A}/\mu\text{s}$	$I_T = 50\text{ A}$		2		$\mu\text{s}$
$t_q$	$T_j = 125\text{ }^\circ\text{C}$ $V_D = 67\% V_{DRM}$ Gate Open	$I_T = 50\text{ A}$ $di/dt = 30\text{ A}/\mu\text{s}$	$V_R = 50\text{ V}$ $dv/dt = 20\text{ V}/\mu\text{s}$		100		$\mu\text{s}$
$dv/dt^*$	$T_j = 125\text{ }^\circ\text{C}$ Linear Slope up to $V_D = 67\% V_{DRM}$	Gate Open		200			V/ $\mu\text{s}$

\* For higher guaranteed values, please consult us.

**PACKAGE MECHANICAL DATA : TO 48 Metal**

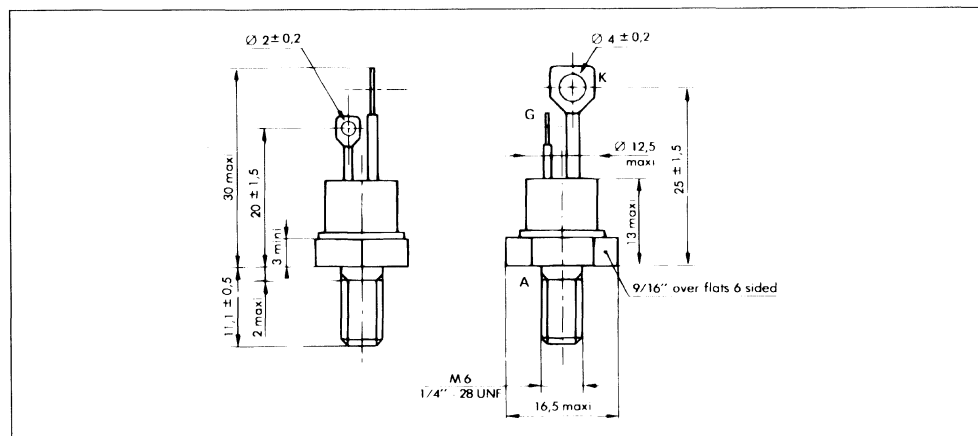

Cooling method : by conduction (method C)  
 Marking : type number  
 Weight :  $13.5 \pm 1\text{ g}$   
 Polarity : anode to case  
 Stud torque :  $3.5\text{ m}\cdot\text{N min} - 3.8\text{ m}\cdot\text{N max}$ .

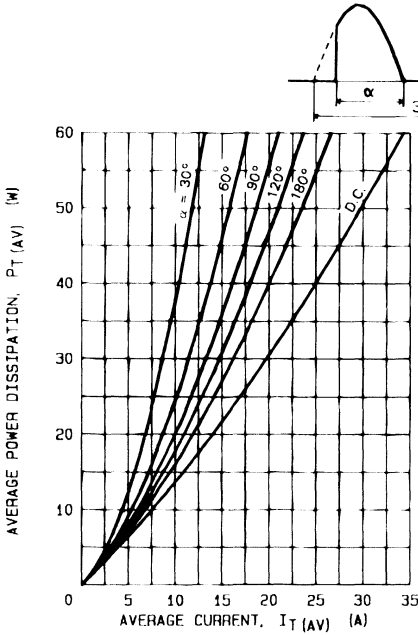

FIG. 1 - MAXIMUM ON-STATE POWER DISSIPATION FOR SINUSOIDAL CURRENT WAVEFORM

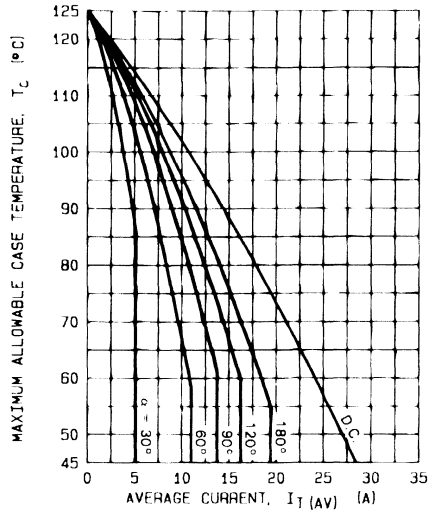

FIG. 2 - MAXIMUM ALLOWABLE CASE TEMPERATURE FOR SINUSOIDAL CURRENT WAVEFORM

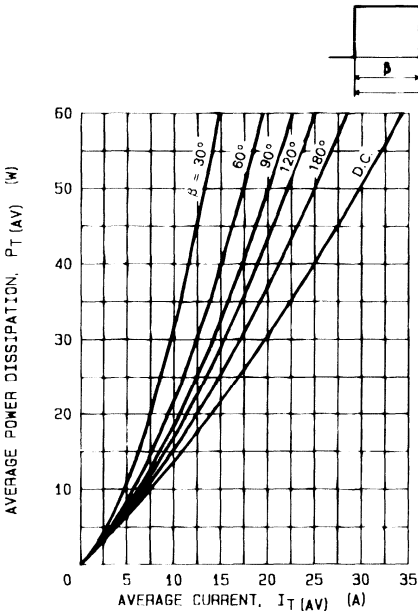

FIG. 3 - MAXIMUM ON-STATE POWER DISSIPATION FOR RECTANGULAR CURRENT WAVEFORM

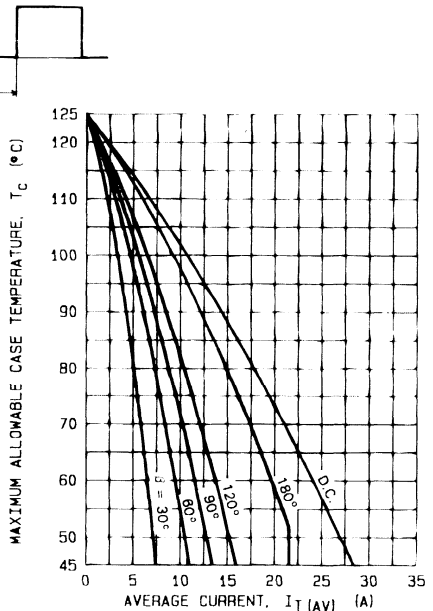

FIG. 4 - MAXIMUM ALLOWABLE CASE TEMPERATURE FOR RECTANGULAR CURRENT WAVEFORM

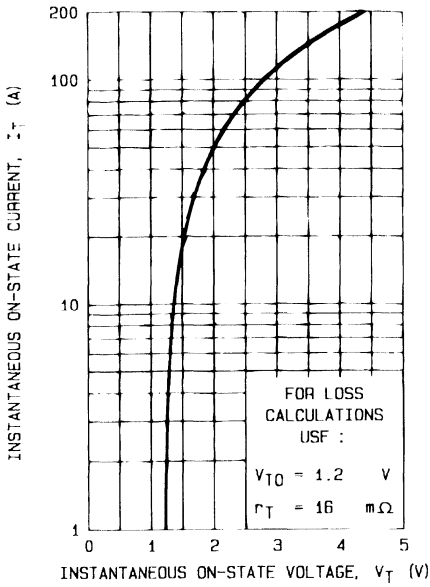

FIG. 5 - MAXIMUM ON-STATE CONDUCTION CHARACTERISTIC ( $T_J = 125^\circ\text{C}$ ).

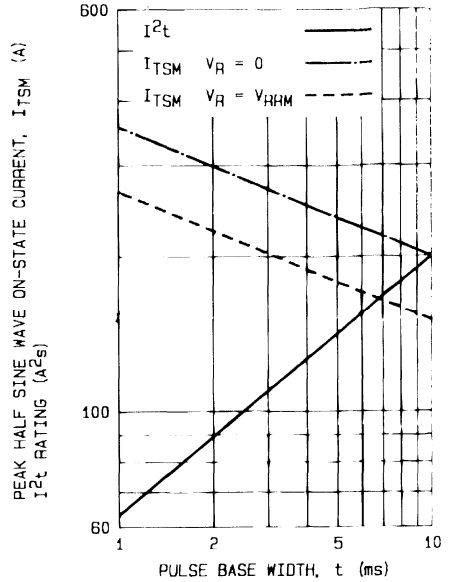

FIG. 6 - NON REPETITIVE SUB-CYCLE SURGE ON-STATE CURRENT AND  $I^2t$  RATINGS (INITIAL  $T_J = 125^\circ\text{C}$ ).

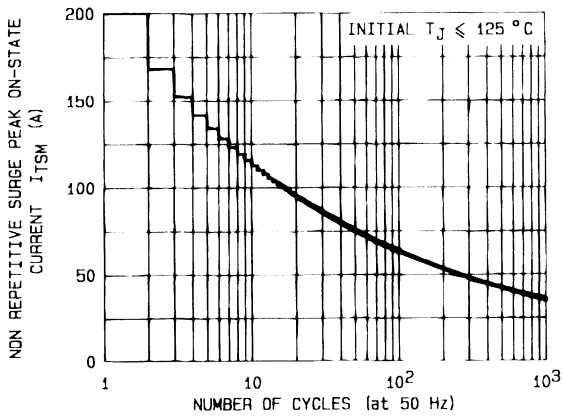
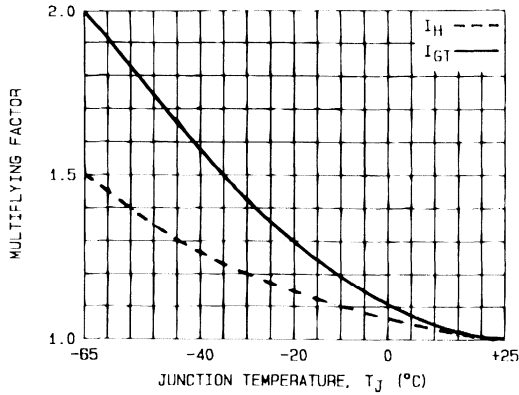
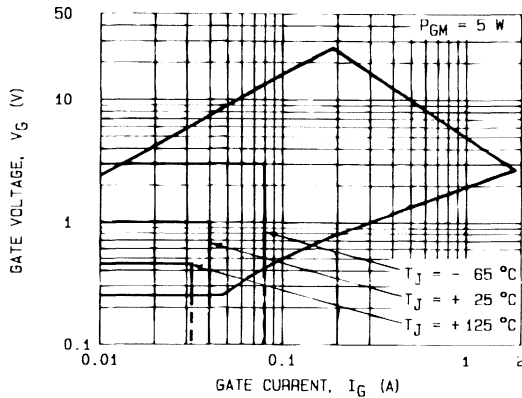

FIG. 7 - NON REPETITIVE SURGE PEAK ON-STATE CURRENT VERSUS NUMBER OF CYCLES.



**FIG.8 - RELATIVE VARIATION OF GATE TRIGGER CURRENT AND HOLDING CURRENT VERSUS JUNCTION TEMPERATURE.**



**FIG.9 - GATE TRIGGER CHARACTERISTICS.**

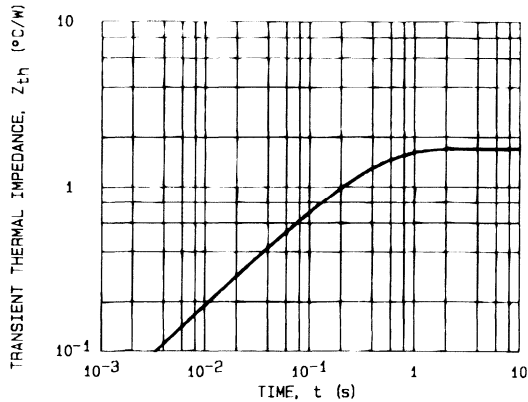

Conduction angle ( $\alpha, \beta$ )	Effective thermal resistance ( $^{\circ}\text{C}/\text{W}$ ) junction to case	
	Sinusoidal	Rectangular
180°	1.84	1.80
120°	1.90	2.55
90°	2.04	2.89
60°	2.38	3.23
30°	3.06	4.08

**FIG.10 - TRANSIENT THERMAL IMPEDANCE JUNCTION TO CASE.**





## THYRISTORS

- GLASS PASSIVATED CHIP
- HIGH STABILITY AND RELIABILITY

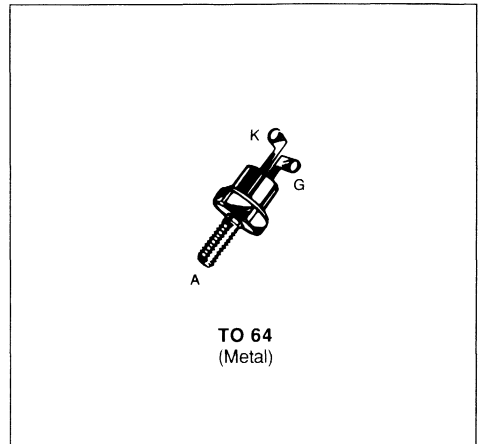

### DESCRIPTION

General purpose SCR suited for power supplies up to 400 Hz on resistive or inductive loads.

### ABSOLUTE RATINGS (limiting values)

Symbol	Parameter	Value	Unit
$I_{T(RMS)}$	RMS on-state Current (1)	$T_c = 90\text{ }^\circ\text{C}$ 7.4	A
$I_{T(AV)}$	Mean on-state Current (1)	$T_c = 90\text{ }^\circ\text{C}$ 4.7	A
$I_{TSM}$	Non Repetitive Surge Peak on-state Current ( $T_j$ initial $\leq 125\text{ }^\circ\text{C}$ ) (2)	$t = 8.3\text{ ms}$ 84	A
		$t = 10\text{ ms}$ 80	
$I^2t$	$I^2t$ Value for Fusing	$t = 10\text{ ms}$ 32	$\text{A}^2\text{s}$
$di/dt$	Critical Rate of Rise of on-state Current (3)	100	$\text{A}/\mu\text{s}$
$T_{stg}$ $T_j$	Storage and Operating Junction Temperature Range	- 65 to 150	$^\circ\text{C}$
		- 65 to 125	$^\circ\text{C}$

Symbol	Parameter	2N1770	2N1771	2N1772	2N1773	2N1774	2N1775	2N1776	2N1777	2N1778	2N2619	Unit
$V_{DRM}$ $V_{RRM}$	Repetitive Peak off-state Voltage (4)	25	50	100	150	200	250	300	400	500	600	V

(1) Single phase circuit,  $180^\circ$  conduction angle.

(2) Half sine wave.

(3)  $I_G = 150\text{ mA}$   $di_G/dt = 1\text{ A}/\mu\text{s}$ .

(4)  $T_j = 125\text{ }^\circ\text{C}$ .

### THERMAL RESISTANCES

Symbol	Parameter	Value	Unit
$R_{th(j-c)}$	Junction-case for D.C.	4.4	$^\circ\text{C}/\text{W}$
$R_{th(c-h)}$	Contact (case to heatsink)	0.4	$^\circ\text{C}/\text{W}$

**GATE CHARACTERISTICS** (maximum values)

$P_{GM} = 5 \text{ W}$  ( $t_p = 100 \mu\text{s}$ )       $I_{FGM} = 2 \text{ A}$  ( $t_p = 100 \mu\text{s}$ )       $V_{RGM} = 5 \text{ V}$   
 $P_{G(AV)} = 0.5 \text{ W}$        $V_{FGM} = 10 \text{ V}$  ( $t_p = 100 \mu\text{s}$ )

**ELECTRICAL CHARACTERISTICS**

Symbol	Test Conditions			Min.	Typ.	Max.	Unit
$I_{GT}$	$T_j = 25 \text{ }^\circ\text{C}$ Pulse Duration > 20 $\mu\text{s}$	$V_D = 12 \text{ V}$	$R_L = 33 \text{ } \Omega$		10	15	mA
$V_{GT}$	$T_j = 25 \text{ }^\circ\text{C}$ Pulse Duration > 20 $\mu\text{s}$	$V_D = 12 \text{ V}$	$R_L = 33 \text{ } \Omega$			1.5	V
$V_{GD}$	$T_j = 125 \text{ }^\circ\text{C}$	$V_D = V_{DRM}$	$R_L = 3.3 \text{ k}\Omega$	.2			V
$I_H$	$T_j = 25 \text{ }^\circ\text{C}$	$I_T = 0.5 \text{ A}$	Gate Open		20	30	mA
$I_L$	$T_j = 25 \text{ }^\circ\text{C}$ Pulse Duration > 20 $\mu\text{s}$	$V_D = 12 \text{ V}$	$I_G = 30 \text{ mA}$		40		mA
$V_{TM}$	$T_j = 25 \text{ }^\circ\text{C}$	$I_{TM} = 15 \text{ A}$	$t_p = 10 \text{ ms}$			1.85	V
$I_{DRM}$	$V_{DRM}$ Specified		$T_j = 25 \text{ }^\circ\text{C}$			0.02	mA
			$T_j = 125 \text{ }^\circ\text{C}$		1	2	
$I_{RRM}$	$V_{RRM}$ Specified		$T_j = 25 \text{ }^\circ\text{C}$			0.02	mA
			$T_j = 125 \text{ }^\circ\text{C}$		1	2	
$t_{gt}$	$T_j = 25 \text{ }^\circ\text{C}$ $I_G = 200 \text{ mA}$	$V_D = V_{DRM}$ $di_G/dt = 2 \text{ A}/\mu\text{s}$	$I_T = 15 \text{ A}$		2		$\mu\text{s}$
$t_q$	$T_j = 125 \text{ }^\circ\text{C}$ $V_D = 67 \% V_{DRM}$ Gate Open	$I_T = 15 \text{ A}$ $di/dt = 30 \text{ A}/\mu\text{s}$	$V_R = 24 \text{ V}$ $dv/dt = 20 \text{ V}/\mu\text{s}$		30		$\mu\text{s}$
$dv/dt^*$	$T_j = 125 \text{ }^\circ\text{C}$ Linear Slope up to $V_D = 67 \% V_{DRM}$	Gate Open		200			V/ $\mu\text{s}$

\* For higher guaranteed values, please consult us.

**PACKAGE MECHANICAL DATA**

TO 64 Metal

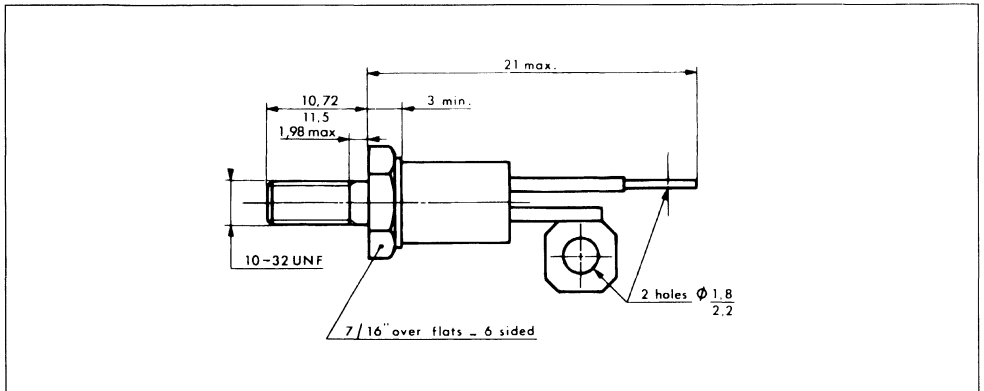

Cooling method : by conduction (method C)  
 Marking : type number  
 Weight : 5 g  
 Polarity : anode to case  
 Stud torque : 3.5 m.N min - 3.8 m.N max

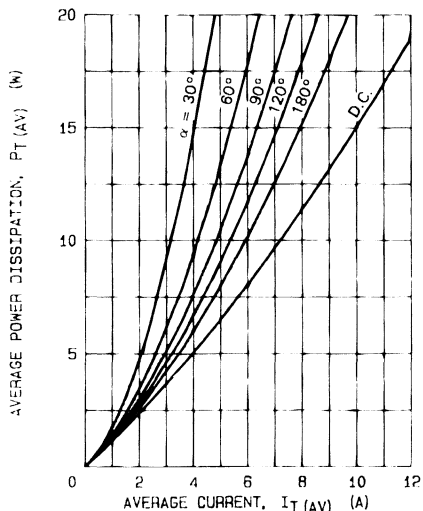
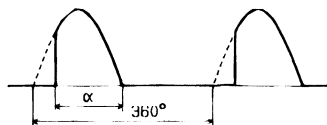

FIG. 1 - MAXIMUM ON-STATE POWER DISSIPATION FOR SINUSOIDAL CURRENT WAVEFORM

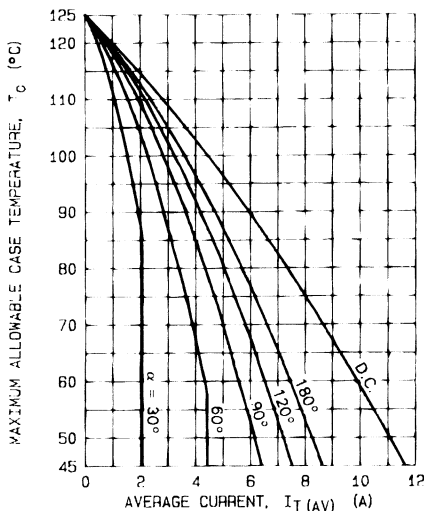

FIG. 2 - MAXIMUM ALLOWABLE CASE TEMPERATURE FOR SINUSOIDAL CURRENT WAVEFORM

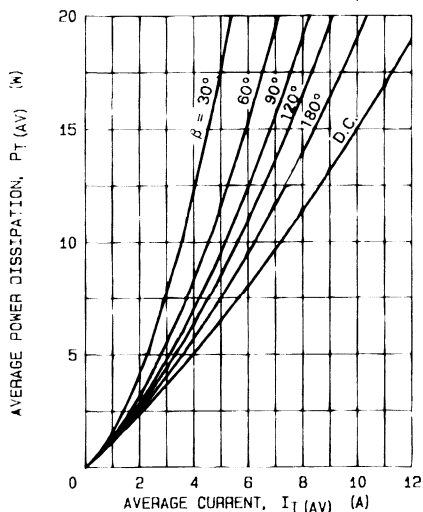
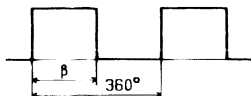

FIG. 3 - MAXIMUM ON-STATE POWER DISSIPATION FOR RECTANGULAR CURRENT WAVEFORM

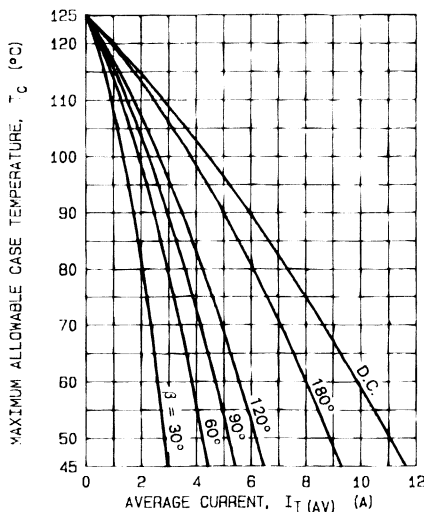

FIG. 4 - MAXIMUM ALLOWABLE CASE TEMPERATURE FOR RECTANGULAR CURRENT WAVEFORM

D882N1770P3

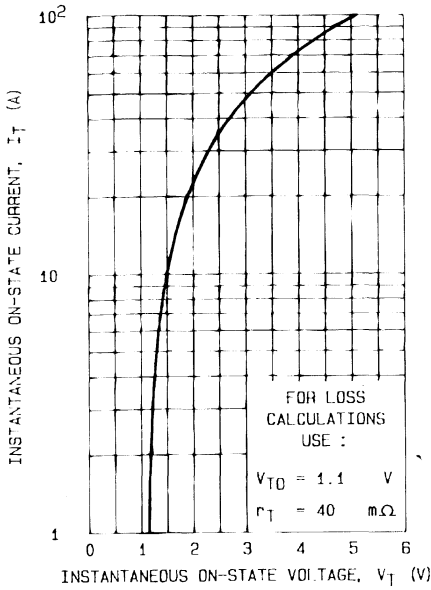

FIG. 5 - MAXIMUM ON-STATE CONDUCTION CHARACTERISTIC ( $T_J = 125^\circ\text{C}$ ).

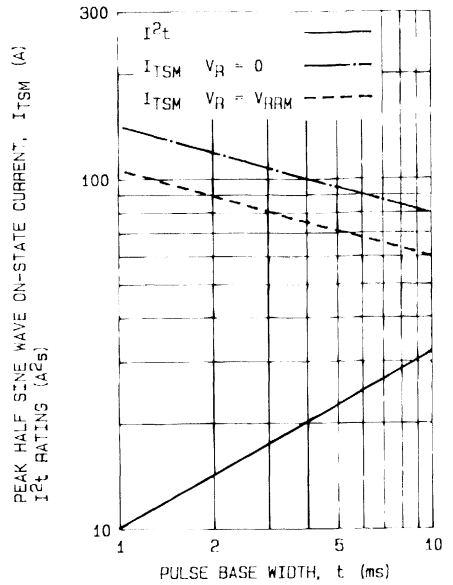

FIG. 6 - NON REPETITIVE SUB-CYCLE SURGE ON-STATE CURRENT AND  $I^2t$  RATING (INITIAL  $T_J = 125^\circ\text{C}$ ).

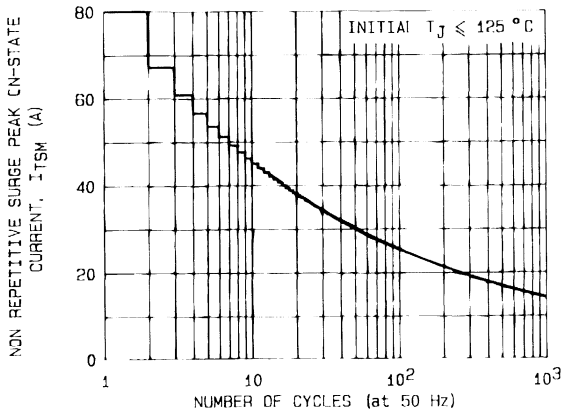

FIG. 7 - NON REPETITIVE SURGE PEAK ON-STATE CURRENT VERSUS NUMBER OF CYCLES.

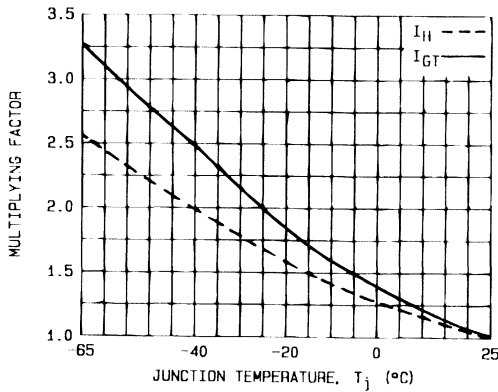

FIG. 8 - RELATIVE VARIATION OF GATE TRIGGER CURRENT AND HOLDING CURRENT VERSUS JUNCTION TEMPERATURE.

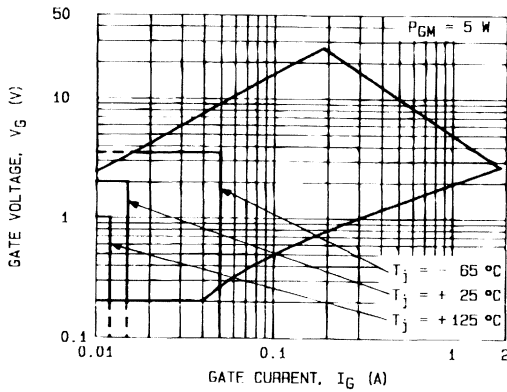

FIG. 9 - GATE TRIGGER CHARACTERISTICS.

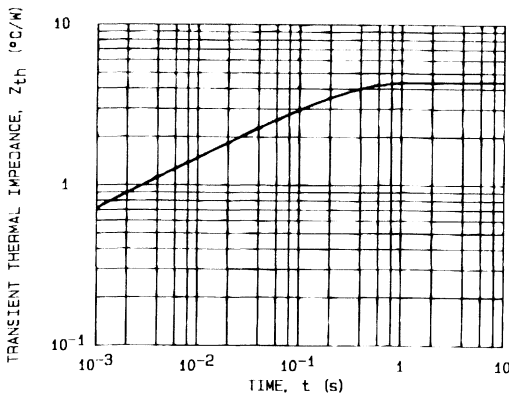

FIG. 10 - TRANSIENT THERMAL IMPEDANCE JUNCTION TO CASE.

Conduction angle ( $\alpha, \beta$ )	Effective thermal resistance ( $^{\circ}\text{C}/\text{W}$ ) junction to case	
	Sinusoidal	Rectangular
180°	4.75	4.66
120°	4.93	6.60
90°	5.28	7.48
60°	6.16	8.36
30°	7.92	.10





**FAST SWITCHING THYRISTORS**

- GLASS PASSIVATED CHIP
- HIGH STABILITY AND RELIABILITY
- HIGH di/dt AND dv/dt RATINGS
- $t_q \leq 15 \mu s$

Thread : 1/4" -28 UNF : type N°  
M6 on request : type N° + suffix M



**TO 48**  
(Metal)

**DESCRIPTION**

SCR designed for high frequency power switching applications.

**ABSOLUTE RATINGS** (limiting values)

Symbol	Parameter	Value	Unit
$I_{T(RMS)}$	RMS on-state Current (1)	$T_C = 40^\circ C$	35 A
$I_{T(AV)}$	Mean on-state Current (1)	$T_C = 40^\circ C$	22.5 A
$I_{TSM}$	Non Repetitive Surge Peak on-state Current ( $T_j$ initial $\leq 120^\circ C$ ) (2)	$t = 8.3$ ms	210 A
		$t = 10$ ms	200
$I^2t$	$I^2t$ Value for Fusing	$t = 10$ ms	200 $A^2s$
di/dt	Critical Rate of Rise of on-state Current (3)	400	$A/\mu s$
$T_{stg}$ $T_j$	Storage and Operating Junction Temperature Range	- 65 to 150	$^\circ C$
		- 65 to 120	$^\circ C$

Symbol	Parameter	2N 36..					Unit
		49	50	51	52	53	
$V_{DRM}$ $V_{RRM}$	Repetitive Peak off-state Voltage (4)	50	100	200	300	400	V

(1) Single phase circuit, 180° conduction angle.

(2) Half sine wave.

(3)  $I_G = 1$  A  $di/dt = 1$  A/ $\mu s$ .

(4)  $T_j = 120^\circ C$ .

**THERMAL RESISTANCES**

Symbol	Parameter	Value	Unit
$R_{th(j-c)}$	Junction-case for D.C.	1.45	$^\circ C/W$
$R_{th(c-h)}$	Contact (case to heatsink)	0.40	$^\circ C/W$

**GATE CHARACTERISTICS** (maximum values)

$P_{GM} = 60 \text{ W}$  ( $t_p = 500 \mu\text{s}$ )       $I_{FGM} = 10 \text{ A}$  ( $t_p = 500 \mu\text{s}$ )       $V_{RGM} = 5 \text{ V}$   
 $P_{G(AV)} = 1 \text{ W}$        $V_{FGM} = 15 \text{ V}$  ( $t_p = 500 \mu\text{s}$ )

**ELECTRICAL CHARACTERISTICS**

Symbol	Test Conditions			Min.	Typ.	Max.	Unit
$I_{GT}$	$T_j = 25 \text{ }^\circ\text{C}$ Pulse Duration > 20 $\mu\text{s}$	$V_D = 12 \text{ V}$	$R_L = 33 \text{ } \Omega$			180	mA
$V_{GT}$	$T_j = 25 \text{ }^\circ\text{C}$ Pulse Duration > 20 $\mu\text{s}$	$V_D = 12 \text{ V}$	$R_L = 33 \text{ } \Omega$			1.5	V
$V_{GD}$	$T_j = 120 \text{ }^\circ\text{C}$	$V_D = V_{DRM}$	$R_L = 3.3 \text{ k}\Omega$	0.2			V
$I_H$	$T_j = 25 \text{ }^\circ\text{C}$	$I_T = 500 \text{ mA}$	Gate Open		70		mA
$I_L$	$T_j = 25 \text{ }^\circ\text{C}$ Pulse Duration > 20 $\mu\text{s}$	$V_D = 12 \text{ V}$	$I_G = 360 \text{ mA}$		140		mA
$V_{TM}$	$T_j = 25 \text{ }^\circ\text{C}$	$I_{TM} = 25 \text{ A}$	$t_p = 10 \text{ ms}$			2.05	V
$I_{DRM}$	$T_j = 120 \text{ }^\circ\text{C}$	$V_{DRM}$ Specified				6	mA
$I_{RRM}$	$T_j = 120 \text{ }^\circ\text{C}$	$V_{RRM}$ Specified				6	mA
$t_{gt}$	$T_j = 25 \text{ }^\circ\text{C}$ $I_G = 500 \text{ mA}$	$V_D = V_{DRM}$ $di_G/dt = 5 \text{ A}/\mu\text{s}$	$I_T = 25 \text{ A}$		1		$\mu\text{s}$
$t_q$	$T_j = 120 \text{ }^\circ\text{C}$ $V_D = 67 \% V_{DRM}$ $dv/dt = 200 \text{ V}/\mu\text{s}$	$I_T = 25 \text{ A}$ $di/dt = 5 \text{ A}/\mu\text{s}$ Gate Open	$V_R = 15 \text{ V}$			15	$\mu\text{s}$
$dv/dt^*$	$T_j = 120 \text{ }^\circ\text{C}$	Gate Open Linear Slope up to $V_D = 67 \% V_{DRM}$		200			V/ $\mu\text{s}$

\* For higher guaranteed values, please consult us.

**PACKAGE MECHANICAL DATA**

TO 48 Metal

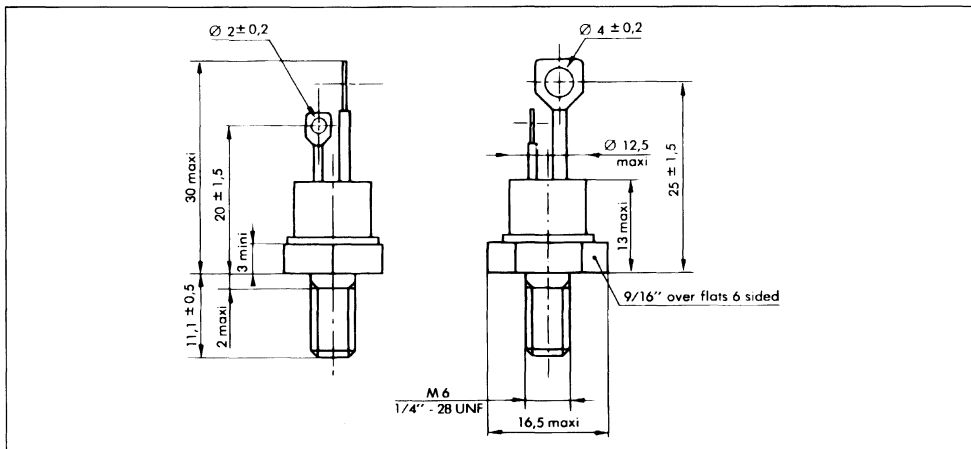

Cooling method : by conduction (method C)

Marking : type number

Weight : 13.5 ± 1 g

Polarity : anode to case

Stud torque : 3.5 m $\Lambda$ N min - 3.8 m $\Lambda$ N max.



SINUSOIDAL CURRENT PULSE DATA

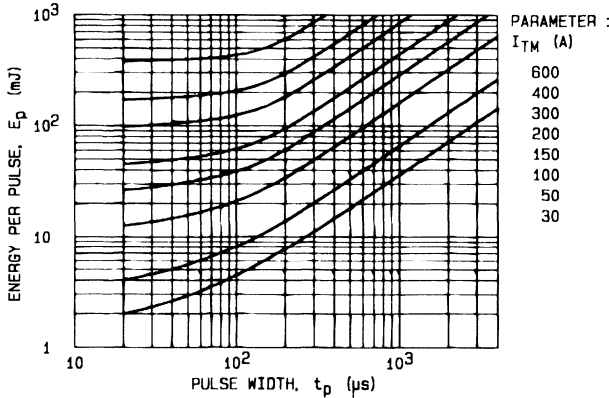

FIG.1 - ENERGY PER PULSE FOR SINUSOIDAL PULSES.

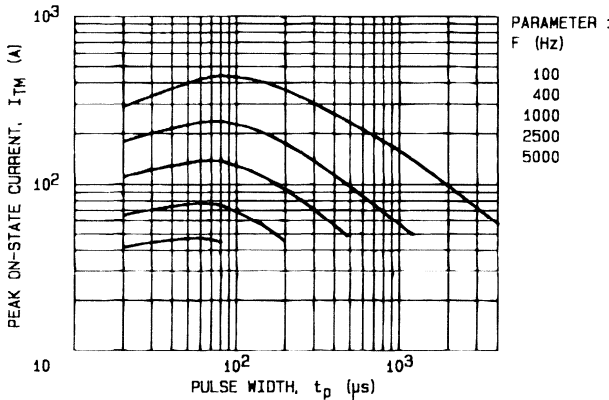

FIG.2 - MAXIMUM ALLOWABLE PEAK ON-STATE CURRENT VERSUS PULSE WIDTH FOR  $T_c = 85^\circ\text{C}$ .

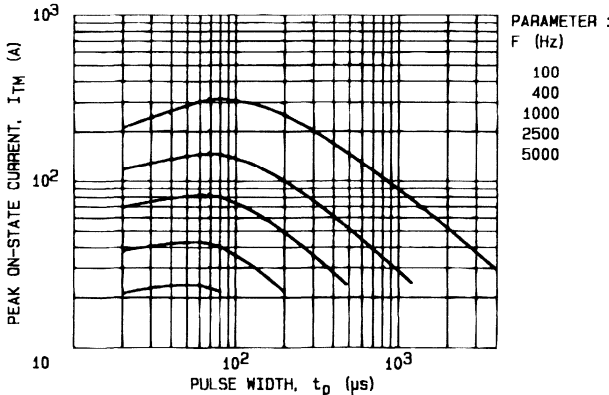
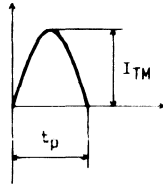

FIG.3 - MAXIMUM ALLOWABLE PEAK ON-STATE CURRENT VERSUS PULSE WIDTH FOR  $T_c = 80^\circ\text{C}$ .

- NOTES :
1.  $V_D = V_R = 200$  Volts.
  2. R.C Snubber,  $C = 0.1 \mu\text{F}$ ,  
 $R = 33 \Omega$ .

TRAPEZOIDAL CURRENT PULSE DATA

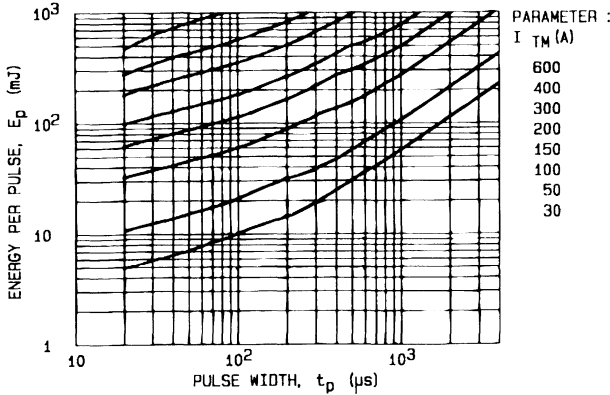
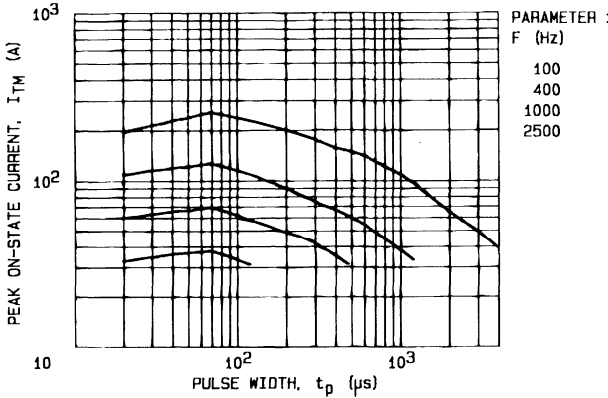

FIG. 4 - ENERGY PER PULSE FOR TRAPEZOIDAL PULSES.



$di/dt = 100 \text{ A}/\mu\text{s}$

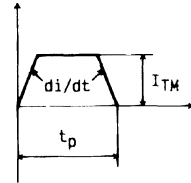
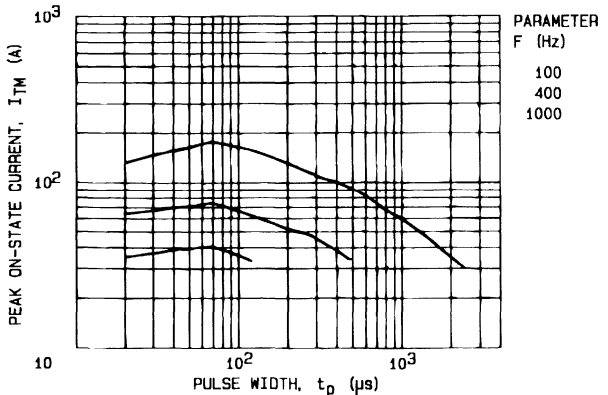

FIG. 5 - MAXIMUM ALLOWABLE PEAK ON-STATE CURRENT VERSUS PULSE WIDTH FOR  $T_c = 85 \text{ }^\circ\text{C}$ .



NOTES :

1.  $V_D = V_R = 200$  Volts.
2. R.C Snubber,  $C = 0.1 \mu\text{F}$ ,  
 $R = 33 \Omega$ .

FIG. 8 - MAXIMUM ALLOWABLE PEAK ON-STATE CURRENT VERSUS PULSE WIDTH FOR  $T_c = 90 \text{ }^\circ\text{C}$ .

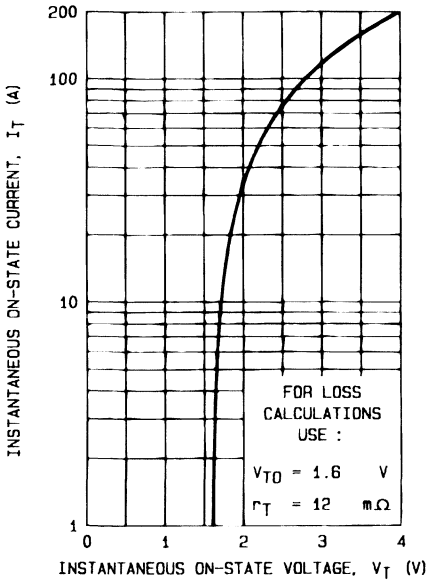

FIG.7 - MAXIMUM ON-STATE CONDUCTION CHARACTERISTIC ( $T_J = 120^\circ\text{C}$ ).

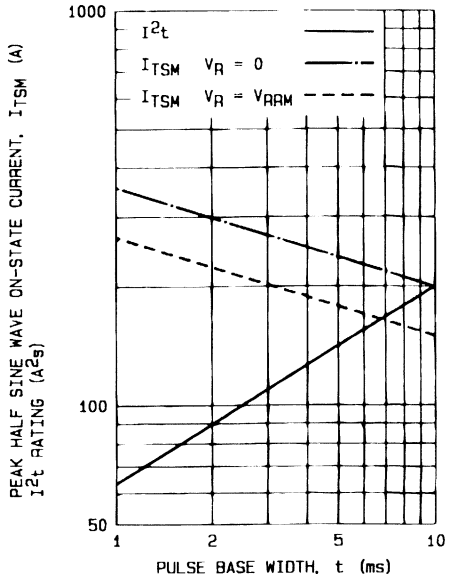

FIG.8 - NON REPETITIVE SUB-CYCLE SURGE ON-STATE CURRENT AND  $I^2t$  RATING (INITIAL  $T_J = 120^\circ\text{C}$ ).

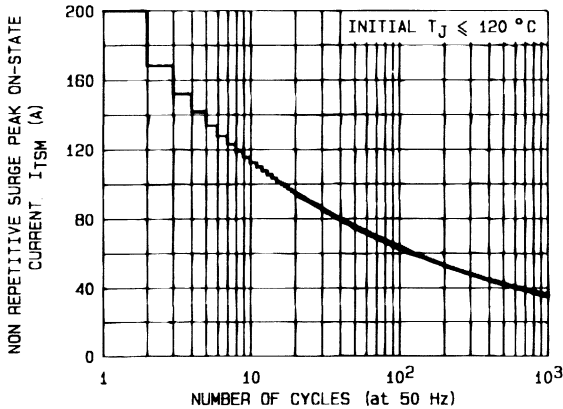

FIG.9 - NON REPETITIVE SURGE PEAK ON-STATE CURRENT VERSUS NUMBER OF CYCLES.

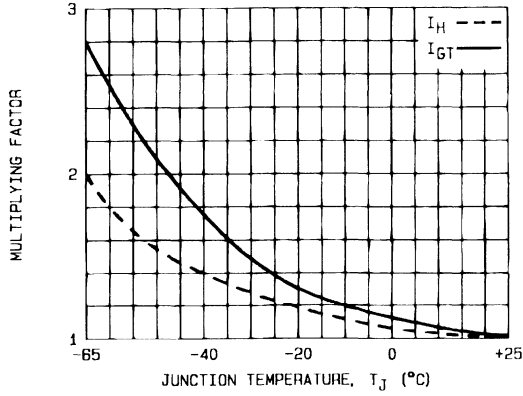

FIG.10 - RELATIVE VARIATION OF GATE TRIGGER CURRENT AND HOLDING CURRENT VERSUS JUNCTION TEMPERATURE.

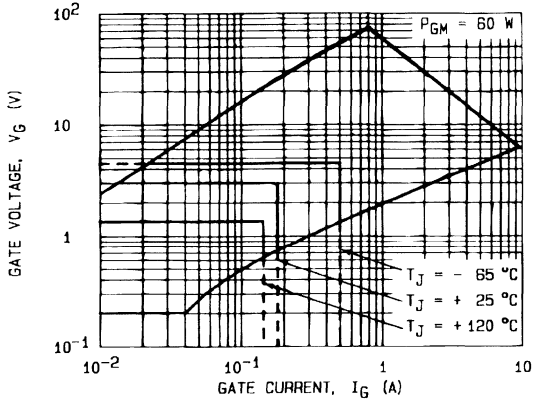

FIG.11 - GATE TRIGGER CHARACTERISTICS.

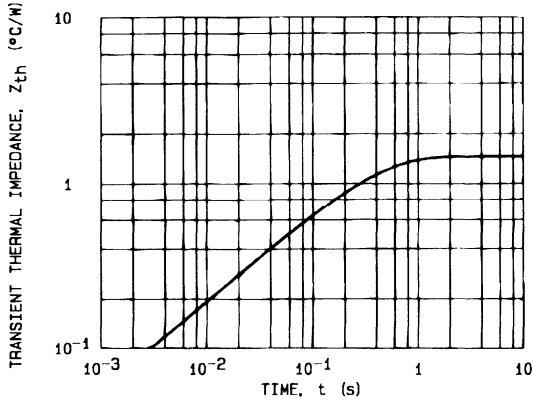
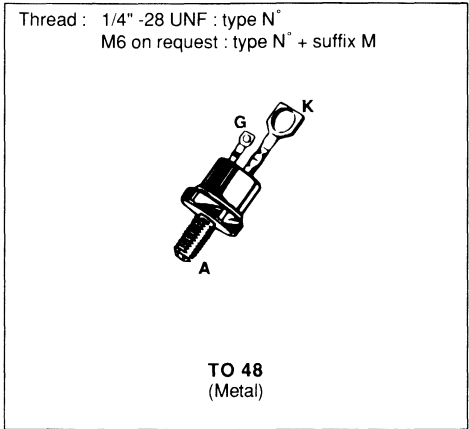

FIG.12 - TRANSIENT THERMAL IMPEDANCE JUNCTION TO CASE.



**FAST SWITCHING THYRISTORS**

- GLASS PASSIVATED CHIP
- HIGH STABILITY AND RELIABILITY
- HIGH di/dt AND dv/dt RATINGS
- $t_q < 10 \mu s$



**DESCRIPTION**

SCR designed for high frequency power switching applications.

**ABSOLUTE RATINGS** (limiting values)

Symbol	Parameter	Value	Unit
$I_{T(RMS)}$	RMS on-state Current (1)	$T_C = 40 \text{ }^\circ\text{C}$ 35	A
$I_{T(AV)}$	Mean on-state Current (1)	$T_C = 40 \text{ }^\circ\text{C}$ 22.5	A
$I_{TSM}$	Non Repetitive Surge Peak on-state Current ( $T_j$ initial $\leq 120 \text{ }^\circ\text{C}$ ) (2)	$t = 8.3 \text{ ms}$	210
		$t = 10 \text{ ms}$	200
$I^2t$	$I^2t$ Value for Fusing	$t = 10 \text{ ms}$ 200	$\text{A}^2\text{s}$
di/dt	Critical Rate of Rise of on-state Current (3)	400	$\text{A}/\mu\text{s}$
$T_{stg}$ $T_j$	Storage and Operating Junction Temperature Range	- 65 to 150 - 65 to 120	$^\circ\text{C}$ $^\circ\text{C}$

Symbol	Parameter	2N 36..					Unit
		54	55	56	57	58	
$V_{DRM}$ $V_{RRM}$	Repetitive Peak off-state Voltage (4)	50	100	200	300	400	V

- (1) Single phase circuit, 180° conduction angle.  
 (2) Half sine wave.  
 (3)  $I_G = 1 \text{ A}$   $di_G/dt = 1 \text{ A}/\mu\text{s}$ .  
 (4)  $T_j = 120 \text{ }^\circ\text{C}$ .

**THERMAL RESISTANCES**

Symbol	Parameter	Value	Unit
$R_{th(j-c)}$	Junction-case for D.C.	1.45	$^\circ\text{C}/\text{W}$
$R_{th(c-h)}$	Contact (case to heatsink)	0.40	$^\circ\text{C}/\text{W}$

**GATE CHARACTERISTICS** (maximum values)

$P_{GM} = 60 \text{ W}$  ( $t_p = 500 \mu\text{s}$ )       $I_{FGM} = 10 \text{ A}$  ( $t_p = 500 \mu\text{s}$ )       $V_{RGM} = 5 \text{ V}$   
 $P_{G(AV)} = 1 \text{ W}$        $V_{FGM} = 15 \text{ V}$  ( $t_p = 500 \mu\text{s}$ )

**ELECTRICAL CHARACTERISTICS**

Symbol	Test Conditions			Min.	Typ.	Max.	Unit
$I_{GT}$	$T_j = 25 \text{ }^\circ\text{C}$ Pulse Duration > 20 $\mu\text{s}$	$V_D = 12 \text{ V}$	$R_L = 33 \text{ }\Omega$			180	mA
$V_{GT}$	$T_j = 25 \text{ }^\circ\text{C}$ Pulse Duration > 20 $\mu\text{s}$	$V_D = 12 \text{ V}$	$R_L = 33 \text{ }\Omega$			1.5	V
$V_{GD}$	$T_j = 120 \text{ }^\circ\text{C}$	$V_D = V_{DRM}$	$R_L = 3.3 \text{ k}\Omega$	0.2			V
$I_H$	$T_j = 25 \text{ }^\circ\text{C}$	$I_T = 500 \text{ mA}$	Gate Open		70		mA
$I_L$	$T_j = 25 \text{ }^\circ\text{C}$ Pulse Duration > 20 $\mu\text{s}$	$V_D = 12 \text{ V}$	$I_G = 360 \text{ mA}$		140		mA
$V_{TM}$	$T_j = 25 \text{ }^\circ\text{C}$	$I_{TM} = 25 \text{ A}$	$t_p = 10 \text{ ms}$			2.05	V
$I_{DRM}$	$T_j = 120 \text{ }^\circ\text{C}$	$V_{DRM}$ Specified				6	mA
$I_{RRM}$	$T_j = 120 \text{ }^\circ\text{C}$	$V_{RRM}$ Specified				6	mA
$t_{gt}$	$T_j = 25 \text{ }^\circ\text{C}$ $I_G = 500 \text{ mA}$	$V_D = V_{DRM}$ $di_G/dt = 5 \text{ A}/\mu\text{s}$	$I_T = 25 \text{ A}$		1		$\mu\text{s}$
$t_q$	$T_j = 120 \text{ }^\circ\text{C}$ $V_D = 67 \% V_{DRM}$ $dv/dt = 200 \text{ V}/\mu\text{s}$	$I_T = 25 \text{ A}$ $di/dt = 5 \text{ A}/\mu\text{s}$ Gate Open	$V_R = 15 \text{ V}$			10	$\mu\text{s}$
$dv/dt^*$	$T_j = 120 \text{ }^\circ\text{C}$ Linear Slope up to $V_D = 67 \% V_{DRM}$	Gate Open		200			V/ $\mu\text{s}$

\* For higher guaranteed values, please consult us.

**PACKAGE MECHANICAL DATA**

TO 48 Metal

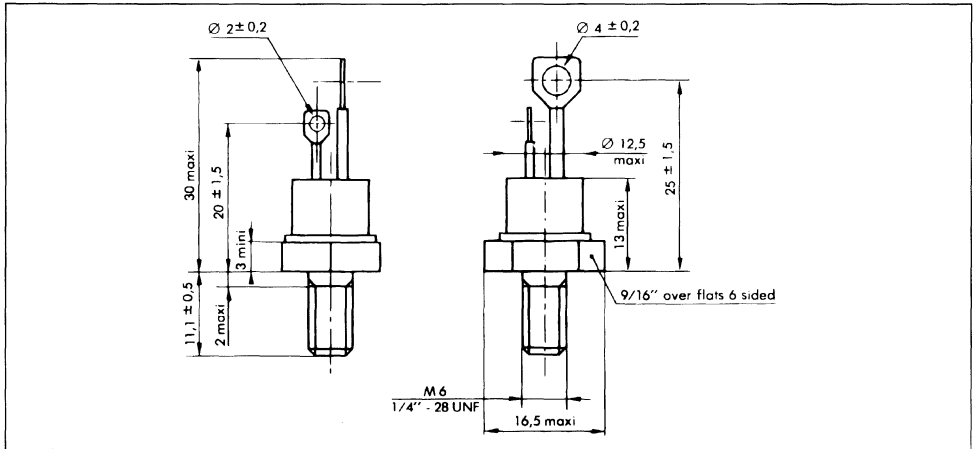

Cooling method : by conduction (method C)

Marking : type number

Weight :  $13.5 \pm 1 \text{ g}$

Polarity : anode to case

Stud torque : 3.5 mAN min - 3.8 mAN max.

SINUSOIDAL CURRENT PULSE DATA

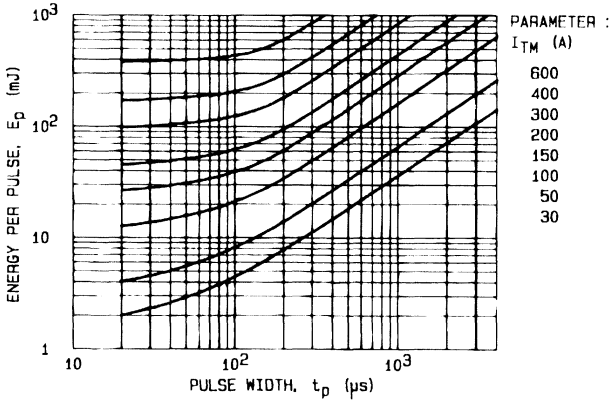

FIG.1 - ENERGY PER PULSE FOR SINUSOIDAL PULSES.

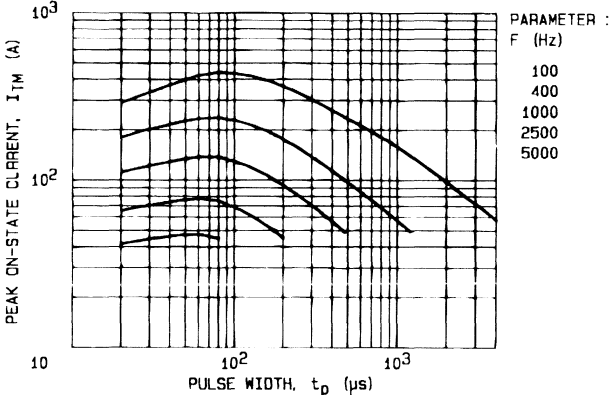

FIG.2 - MAXIMUM ALLOWABLE PEAK ON-STATE CURRENT VERSUS PULSE WIDTH FOR  $T_c = 85^\circ\text{C}$ .

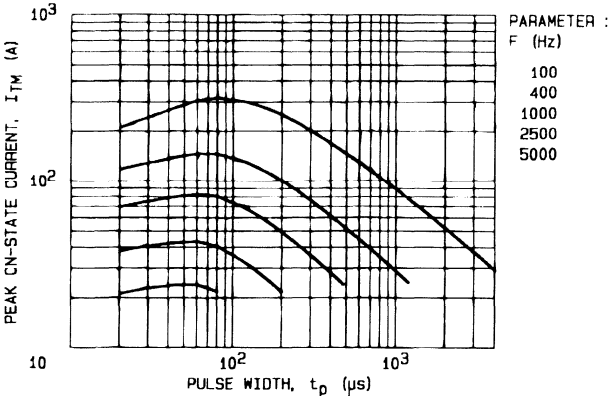
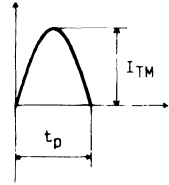

FIG.3 - MAXIMUM ALLOWABLE PEAK ON-STATE CURRENT VERSUS PULSE WIDTH FOR  $T_c = 80^\circ\text{C}$ .

NOTES :

1.  $V_D = V_R = 200$  Volts.
2. R.C Snubber,  $C = 0.1 \mu\text{F}$ ,  
 $R = 33 \Omega$ .

TRAPEZOIDAL CURRENT PULSE DATA

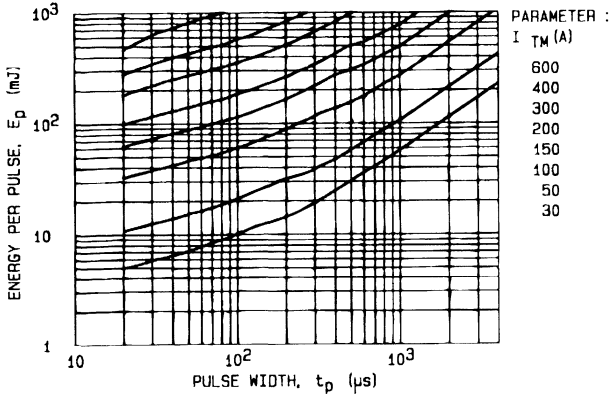
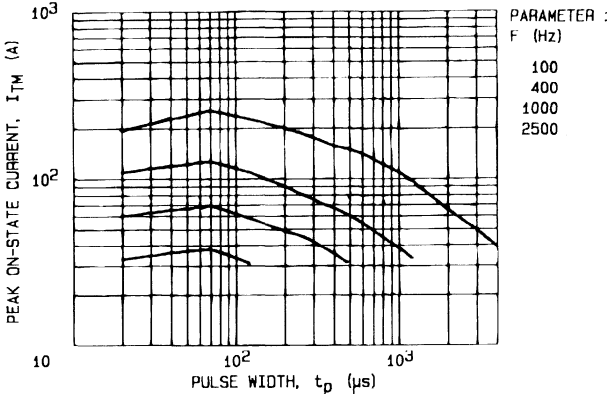

FIG.4 - ENERGY PER PULSE FOR TRAPEZOIDAL PULSES.



$di/dt = 100 \text{ A}/\mu\text{s}$

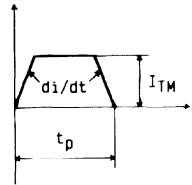
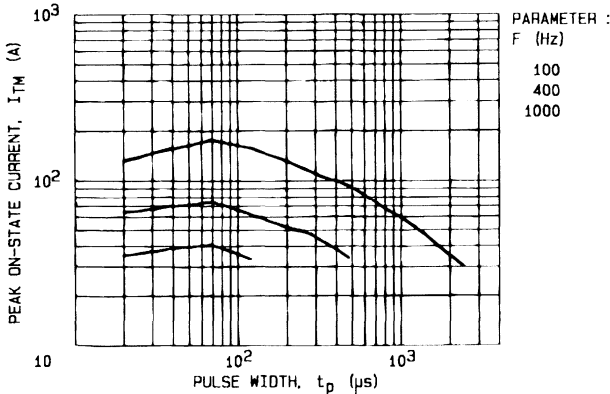

FIG.5 - MAXIMUM ALLOWABLE PEAK ON-STATE CURRENT VERSUS PULSE WIDTH FOR  $T_C = 85^\circ\text{C}$ .



NOTES :

1.  $V_D = V_R = 200$  Volts.
2. R.C Snubber,  $C = 0.1 \mu\text{F}$ ,  
 $R = 33 \Omega$ .

FIG.8 - MAXIMUM ALLOWABLE PEAK ON-STATE CURRENT VERSUS PULSE WIDTH FOR  $T_C = 90^\circ\text{C}$ .



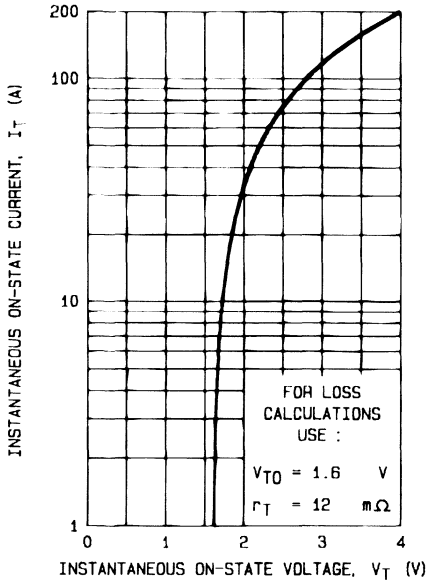

FIG.7 - MAXIMUM ON-STATE CONDUCTION CHARACTERISTIC ( $T_J = 120^\circ\text{C}$ ).

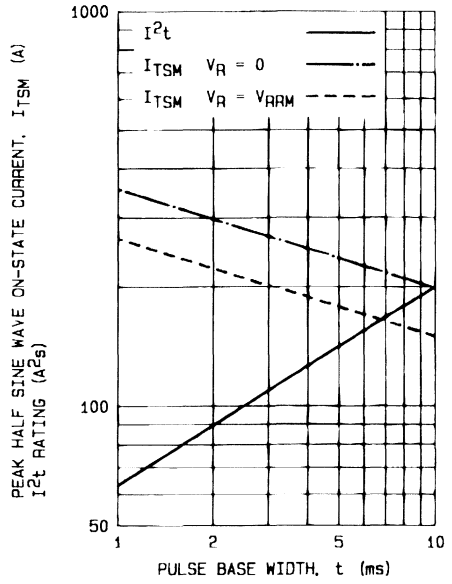

FIG.8 - NON REPETITIVE SUB-CYCLE SURGE ON-STATE CURRENT AND  $I^2t$  RATING (INITIAL  $T_J = 120^\circ\text{C}$ ).

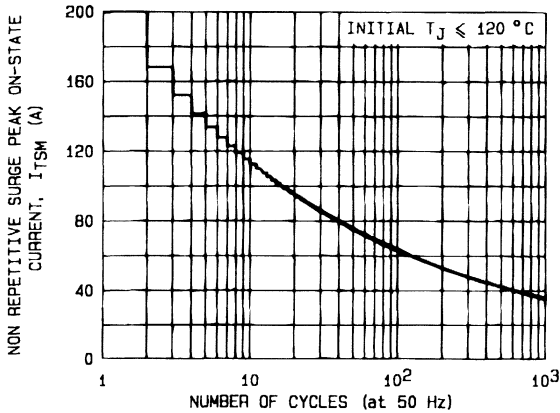

FIG.9 - NON REPETITIVE SURGE PEAK ON-STATE CURRENT VERSUS NUMBER OF CYCLES.

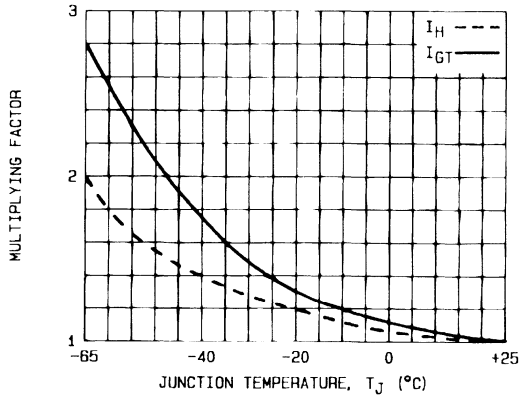

FIG. 10 - RELATIVE VARIATION OF GATE TRIGGER CURRENT AND HOLDING CURRENT VERSUS JUNCTION TEMPERATURE.

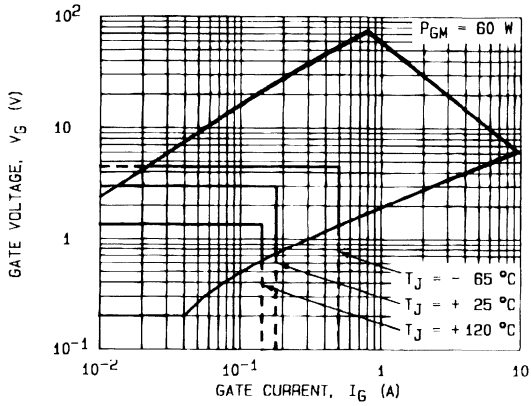

FIG. 11 - GATE TRIGGER CHARACTERISTICS.

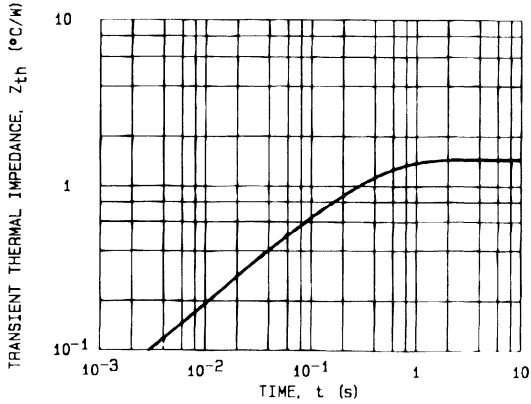

FIG. 12 - TRANSIENT THERMAL IMPEDANCE JUNCTION TO CASE.

## THYRISTORS

- GLASS PASSIVATED CHIP
- HIGH STABILITY AND RELIABILITY

Thread : 1/4" -28 UNF : type N°  
 M6 on request : type N° + suffix M



**TO 48**  
(Metal)

### DESCRIPTION

General purpose SCR suited for power supplies up to 400 Hz on resistive or inductive loads.

### ABSOLUTE RATINGS (limiting values)

Symbol	Parameter	Value	Unit
$I_{T(RMS)}$	RMS on-state Current (1)	$T_c = 75\text{ }^\circ\text{C}$ 35	A
$I_{T(AV)}$	Mean on-state Current (1)	$T_c = 75\text{ }^\circ\text{C}$ 22.5	A
$I_{TSM}$	Non Repetitive Surge Peak on-state Current ( $T_j$ initial $\leq 125\text{ }^\circ\text{C}$ ) (2)	$t = 8.3\text{ ms}$	360
		$t = 10\text{ ms}$	330
$I^2t$	$I^2t$ Value for Fusing	$t = 10\text{ ms}$ 545	A <sup>2</sup> s
di/dt	Critical Rate of Rise of on-state Current (3)	100	A/ $\mu$ s
$T_{stg}$ $T_j$	Storage and Operating Junction Temperature Range	- 40 to 150	$^\circ\text{C}$
		- 40 to 125	$^\circ\text{C}$

Symbol	Parameter	2N5204	2N5205	2N5206	2N5207	Unit
$V_{DRM}$ , $V_{RRM}$	Repetitive Peak off-state Voltage (4)	600	800	1000	1200	V

(1) Single phase circuit, 180° conduction angle.

(2) Half sine wave.

(3)  $I_G = 0.4\text{ A}$  di/dt = 1 A/ $\mu$ s.

(4)  $T_j = 125\text{ }^\circ\text{C}$ .

### THERMAL RESISTANCES

Symbol	Parameter	Value	Unit
$R_{th(j-c)}$	Junction-case for D.C.	1	$^\circ\text{C/W}$
$R_{th(c-h)}$	Contact (case to heatsink)	0.4	$^\circ\text{C/W}$

**GATE CHARACTERISTICS** (maximum values)

$P_{GM} = 60 \text{ W}$  ( $t_p = 500 \mu\text{s}$ )       $I_{FGM} = 10 \text{ A}$  ( $t_p = 500 \mu\text{s}$ )       $V_{RGM} = 5 \text{ V}$   
 $P_{G(AV)} = 1 \text{ W}$        $V_{FGM} = 15 \text{ V}$  ( $t_p = 500 \mu\text{s}$ )

**ELECTRICAL CHARACTERISTICS**

Symbol	Test Conditions			Min.	Typ.	Max.	Unit
$I_{GT}$	$T_j = 25 \text{ }^\circ\text{C}$ Pulse Duration > 20 $\mu\text{s}$	$V_D = 12 \text{ V}$	$R_L = 33 \text{ } \Omega$			40	mA
$V_{GT}$	$T_j = 25 \text{ }^\circ\text{C}$ Pulse Duration > 20 $\mu\text{s}$	$V_D = 12 \text{ V}$	$R_L = 33 \text{ } \Omega$			1.5	V
$V_{GD}$	$T_j = 125 \text{ }^\circ\text{C}$	$V_D = V_{DRM}$	$R_L = 3.3 \text{ k}\Omega$	0.25			V
$I_H$	$T_j = 25 \text{ }^\circ\text{C}$	$I_T = 0.5 \text{ A}$	Gate Open			100	mA
$I_L$	$T_j = 25 \text{ }^\circ\text{C}$ Pulse Duration > 20 $\mu\text{s}$	$V_D = 12 \text{ V}$	$I_G = 80 \text{ mA}$			200	mA
$V_{TM}$	$T_j = 25 \text{ }^\circ\text{C}$	$I_{TM} = 70 \text{ A}$	$t_p = 10 \text{ ms}$			2.3	V
$I_{DRM}$	$V_{DRM}$ Specified			$T_j = 25 \text{ }^\circ\text{C}$		0.02	mA
				$T_j = 125 \text{ }^\circ\text{C}$		3.3	
$I_{RRM}$	$V_{RRM}$ Specified			$T_j = 25 \text{ }^\circ\text{C}$		0.02	mA
				$T_j = 125 \text{ }^\circ\text{C}$		3.3	
$t_{gt}$	$T_j = 25 \text{ }^\circ\text{C}$ $I_G = 200 \text{ mA}$	$V_D = V_{DRM}$ $di_G/dt = 2 \text{ A}/\mu\text{s}$	$I_T = 70 \text{ A}$		2		$\mu\text{s}$
$t_q$	$T_j = 125 \text{ }^\circ\text{C}$ $V_D = 67 \% V_{DRM}$ Gate Open	$I_T = 70 \text{ A}$ $di/dt = 30 \text{ A}/\mu\text{s}$	$V_R = 30 \text{ V}$ $dv/dt = 20 \text{ V}/\mu\text{s}$		100		$\mu\text{s}$
$dv/dt^*$	$T_j = 125 \text{ }^\circ\text{C}$	Gate Open Linear Slope up to $V_D = 67 \% V_{DRM}$		200			V/ $\mu\text{s}$

\* For higher guaranteed values, please consult us.

**PACKAGE MECHANICAL DATA : TO 48 Metal**

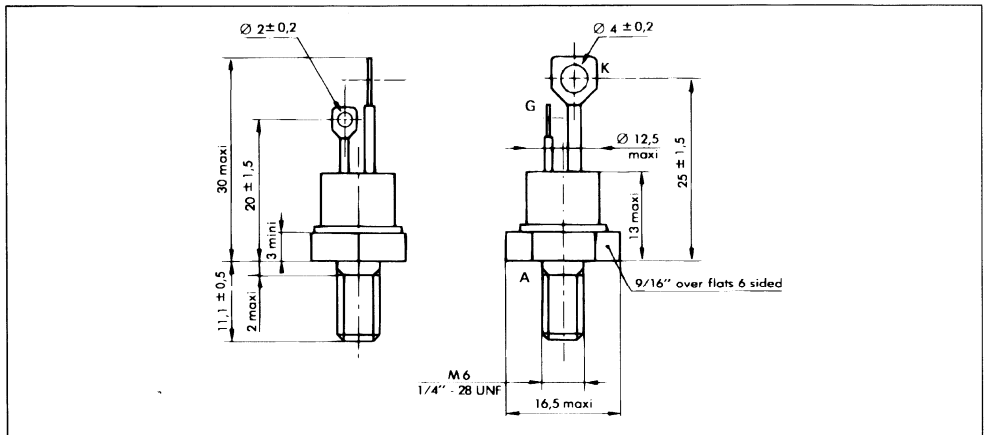

Cooling method : by conduction (method C)  
 Marking : type number  
 Weight :  $13.5 \pm 1 \text{ g}$   
 Polarity : anode to case  
 Stud torque : 3.5 mAN min - 3.8 mAN max.

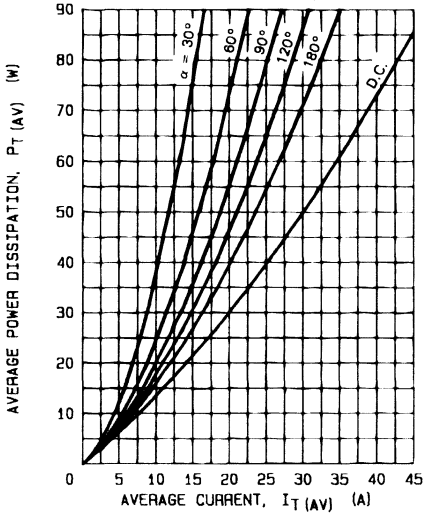
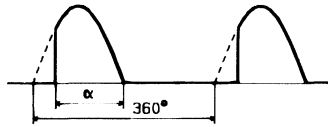

FIG.1 - MAXIMUM ON-STATE POWER DISSIPATION FOR SINUSOIDAL CURRENT WAVEFORM

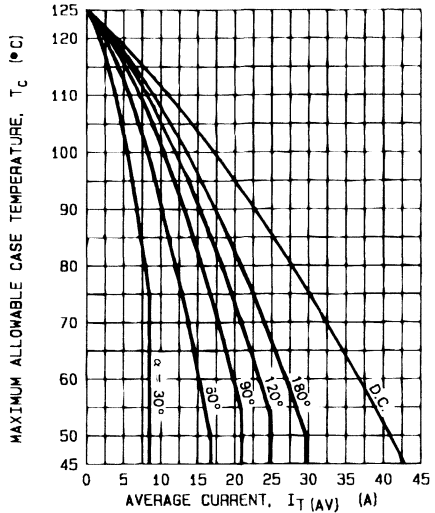

FIG.2 - MAXIMUM ALLOWABLE CASE TEMPERATURE FOR SINUSOIDAL CURRENT WAVEFORM

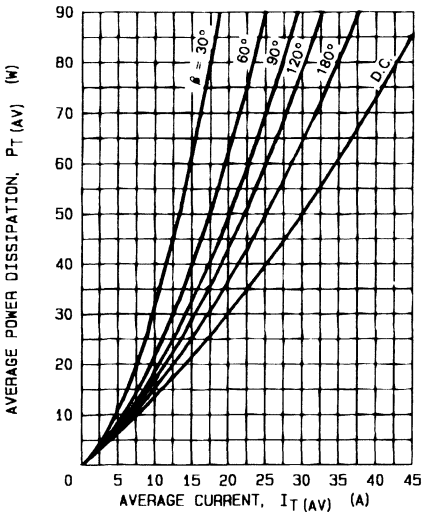
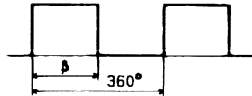

FIG.3 - MAXIMUM ON-STATE POWER DISSIPATION FOR RECTANGULAR CURRENT WAVEFORM

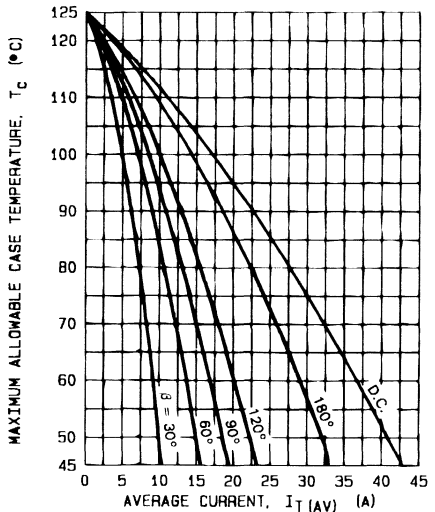

FIG.4 - MAXIMUM ALLOWABLE CASE TEMPERATURE FOR RECTANGULAR CURRENT WAVEFORM

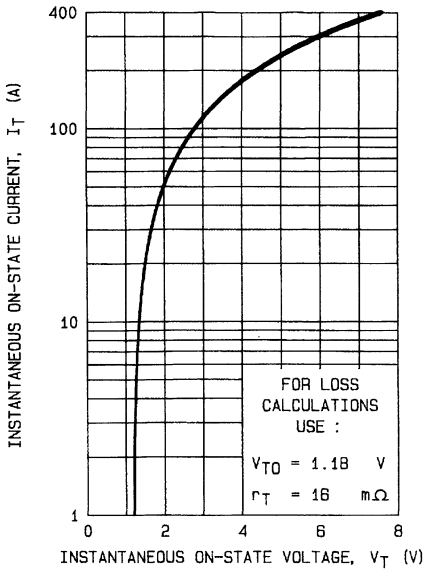

FIG. 5 - MAXIMUM ON-STATE CONDUCTION CHARACTERISTIC ( $T_J = 125^\circ\text{C}$ ).

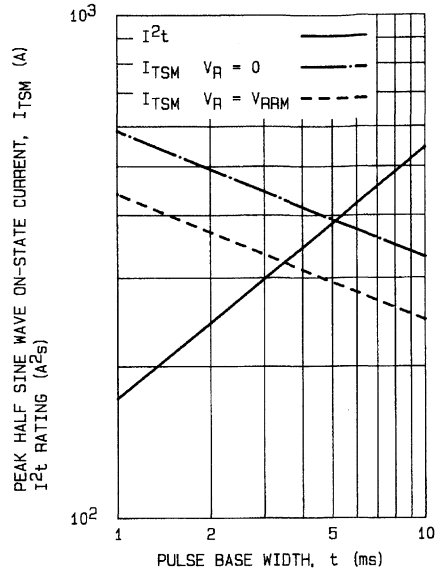

FIG. 6 - NON REPETITIVE SUB-CYCLE SURGE ON-STATE CURRENT AND  $I^2t$  RATING (INITIAL  $T_J = 125^\circ\text{C}$ ).

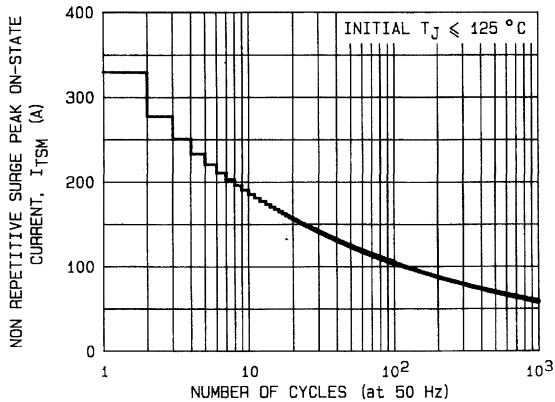

FIG. 7 - NON REPETITIVE SURGE PEAK ON-STATE CURRENT VERSUS NUMBER OF CYCLES.

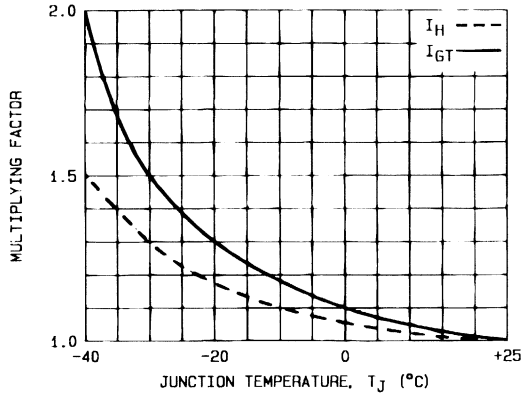

FIG.8 - RELATIVE VARIATION OF GATE TRIGGER CURRENT AND HOLDING CURRENT VERSUS JUNCTION TEMPERATURE.

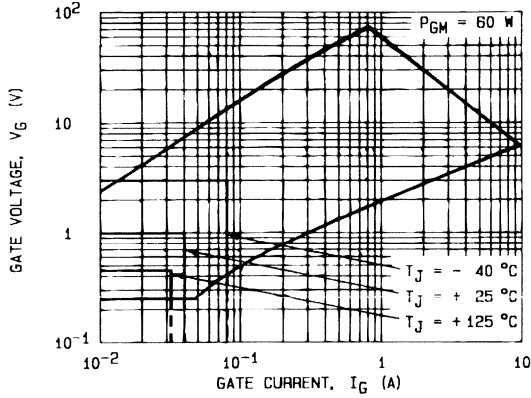
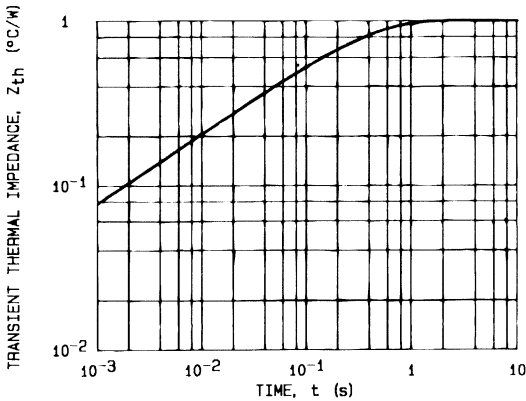

FIG.9 - GATE TRIGGER CHARACTERISTICS.



Conduction angle ( $\alpha, \beta$ )	Effective thermal resistance ( $^{\circ}\text{C}/\text{W}$ ) junction to case	
	Sinusoidal	Rectangular
180°	1.08	1.06
120°	1.12	1.50
90°	1.20	1.70
60°	1.40	1.90
30°	1.80	2.40

FIG.10 - TRANSIENT THERMAL IMPEDANCE JUNCTION TO CASE.





## FAST SWITCHING THYRISTORS

- GLASS PASSIVATED CHIP
- HIGH STABILITY AND RELIABILITY
- HIGH di/dt AND dv/dt RATINGS
- $t_q \leq 12\mu\text{s}$  FOR BTW30-600/800  
 $\leq 20\mu\text{s}$  FOR BTW30-1000/1200

Thread : 1/4" -28 UNF : type N°  
 M6 on request : type N° + suffix M



**TO 48**  
(Metal)

### DESCRIPTION

SCR designed for high frequency power switching applications.

### ABSOLUTE RATINGS (limiting values)

Symbol	Parameter		Value	Unit
$I_{T(RMS)}$	RMS on-state Current (1)	$T_C = 60\text{ }^\circ\text{C}$	25	A
$I_{T(AV)}$	Mean on-state Current (1)	$T_C = 60\text{ }^\circ\text{C}$	16	A
$I_{TSM}$	Non Repetitive Surge Peak on-state Current ( $T_j$ initial $\leq 125\text{ }^\circ\text{C}$ ) (2)	$t = 8.3\text{ ms}$	210	A
		$t = 10\text{ ms}$	200	
$I^2t$	$I^2t$ Value for Fusing	$t = 10\text{ ms}$	200	$\text{A}^2\text{s}$
di/dt	Critical Rate of Rise of on-state Current (3)		200	$\text{A}/\mu\text{s}$
$T_{stg}$ $T_j$	Storage and Operating Junction Temperature Range		- 40 to150 - 40 to125	$^\circ\text{C}$ $^\circ\text{C}$

Symbol	Parameter	BTW 30-				Unit
		600	800	1000	1200	
$V_{DRM}$ $V_{RRM}$	Repetitive Peak off-state Voltage (4)	600	800	1000	1200	V

(1) Single phase circuit, 180° conduction angle.

(2) Half sine wave.

(3)  $I_G = 1\text{ A}$   $di_G/dt = 1\text{ A}/\mu\text{s}$ .

(4)  $T_j = 125\text{ }^\circ\text{C}$ .

### THERMAL RESISTANCES

Symbol	Parameter	Value	Unit
$R_{th(j-c)}$	Junction-case for D.C.	1.4	$^\circ\text{C}/\text{W}$
$R_{th(c-h)}$	Contact (case to heatsink)	0.4	$^\circ\text{C}/\text{W}$

**GATE CHARACTERISTICS** (maximum values)

$P_{GM} = 20 \text{ W}$  ( $t_p = 100 \mu\text{s}$ )       $I_{FGM} = 1 \text{ A}$  ( $t_p = 100 \mu\text{s}$ )       $V_{RGM} = 5 \text{ V}$   
 $P_G(AV) = 1 \text{ W}$        $V_{FGM} = 15 \text{ V}$  ( $t_p = 100 \mu\text{s}$ )

**ELECTRICAL CHARACTERISTICS**

Symbol	Test Conditions			Min.	Typ.	Max.	Unit
$I_{GT}$	$T_J = 25 \text{ }^\circ\text{C}$	$V_D = 12 \text{ V}$	$R_L = 33 \text{ } \Omega$			200	mA
$V_{GT}$	$T_J = 25 \text{ }^\circ\text{C}$	$V_D = 12 \text{ V}$	$R_L = 33 \text{ } \Omega$			1.5	V
$V_{GO}$	$T_J = 125 \text{ }^\circ\text{C}$	$V_D = V_{DRM}$	$R = 3.3 \text{ k}\Omega$	0.2			V
$I_H$	$T_J = 25 \text{ }^\circ\text{C}$	$I_T = 500 \text{ mA}$	Gate Open		70		mA
$I_L$	$T_J = 25 \text{ }^\circ\text{C}$	$V_D = 12 \text{ V}$	$I_G = 400 \text{ mA}$		140		mA
$V_{TM}$	$T_J = 25 \text{ }^\circ\text{C}$	$I_{TM} = 50 \text{ A}$	$t_p = 10 \text{ ms}$			3	V
$I_{DRM}$	$T_J = 100 \text{ }^\circ\text{C}$	$V_{DRM}$ Specified				6	mA
$I_{RRM}$	$T_J = 100 \text{ }^\circ\text{C}$	$V_{RRM}$ Specified				6	mA
$t_{gt}$	$T_J = 25 \text{ }^\circ\text{C}$	$V_D = V_{DRM}$	$I_T = 50 \text{ A}$		1		$\mu\text{s}$
$t_q$	$T_J = 125 \text{ }^\circ\text{C}$	$I_T = 50 \text{ A}$	$V_R = 50 \text{ V}$	BTW 30-600/800	12		$\mu\text{s}$
				BTW 30-1000/1200	20		
$dv/dt^*$	$T_J = 125 \text{ }^\circ\text{C}$	Gate Open Linear Slope up to $V_D = 67 \% V_{DRM}$		200			V/ $\mu\text{s}$

\* For higher guaranteed values, please consult us.

**PACKAGE MECHANICAL DATA**

TO 48 Metal

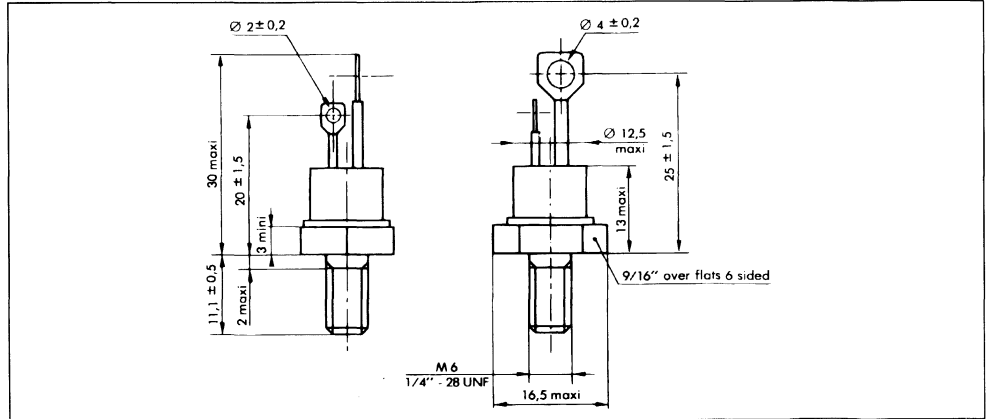

Cooling method : by conduction (method C)  
 Marking : type number  
 Weight :  $13.5 \pm 1 \text{ g}$   
 Polarity : anode to case  
 Stud torque :  $3.5 \text{ m}\cdot\text{N}$  min -  $3.8 \text{ m}\cdot\text{N}$  max.

SINUSOIDAL CURRENT PULSE DATA

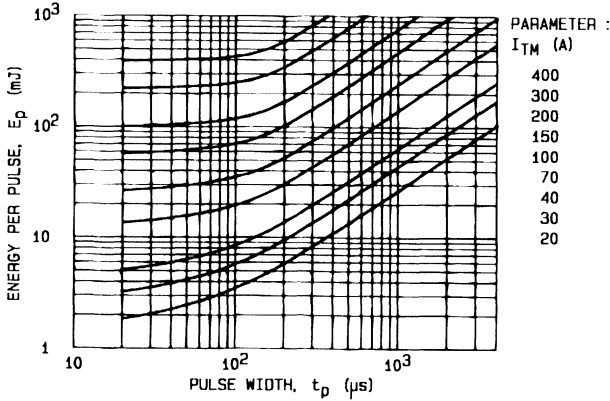

FIG.1 - ENERGY PER PULSE FOR SINUSOIDAL PULSES.

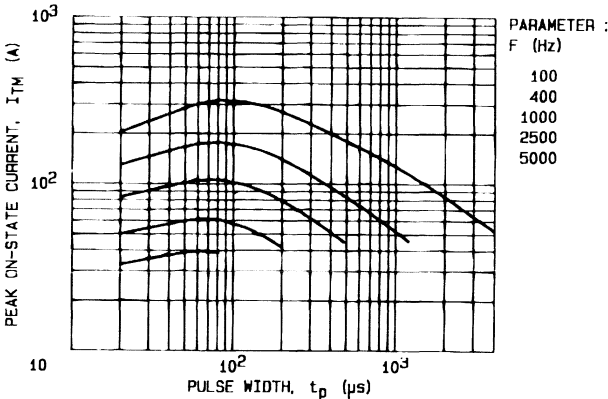

FIG.2 - MAXIMUM ALLOWABLE PEAK ON-STATE CURRENT VERSUS PULSE WIDTH FOR  $T_C = 85^\circ\text{C}$ .

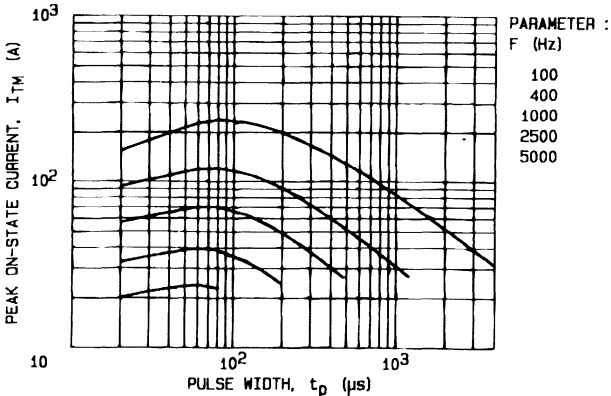
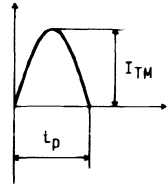

FIG.3 - MAXIMUM ALLOWABLE PEAK ON-STATE CURRENT VERSUS PULSE WIDTH FOR  $T_C = 80^\circ\text{C}$ .

NOTES :

1.  $V_D = V_R = 600$  Volts.
2. R.C Snubber,  $C = 0.1\mu\text{F}$ ,  
 $R = 33\Omega$ .

TRAPEZOIDAL CURRENT PULSE DATA

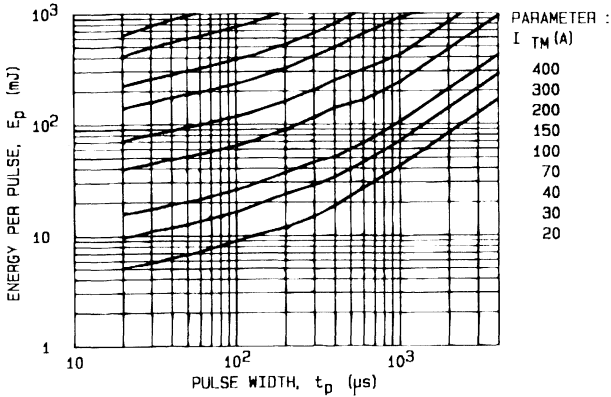

FIG.4 - ENERGY PER PULSE FOR TRAPEZOIDAL PULSES.

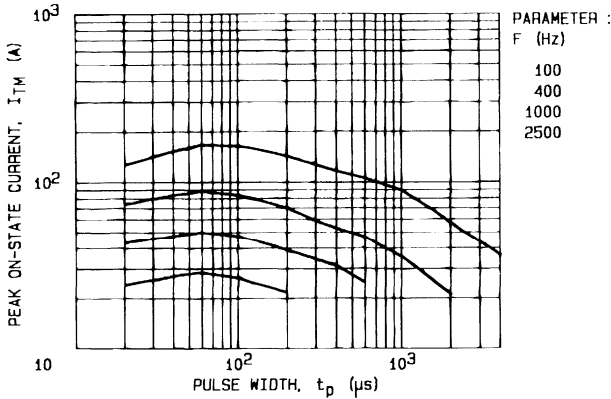

FIG.5 - MAXIMUM ALLOWABLE PEAK ON-STATE CURRENT VERSUS PULSE WIDTH FOR T<sub>C</sub> = 85 °C.

$di/dt = 100 \text{ A}/\mu\text{s}$

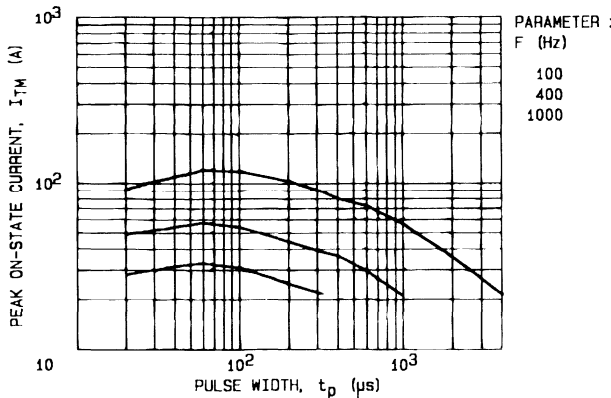
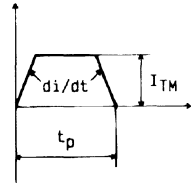

FIG.8 - MAXIMUM ALLOWABLE PEAK ON-STATE CURRENT VERSUS PULSE WIDTH FOR T<sub>C</sub> = 90 °C.

NOTES :

1. V<sub>D</sub> = V<sub>R</sub> = 600 Volts.
2. R.C Snubber, C = 0.1 μF,  
R = 33 Ω.

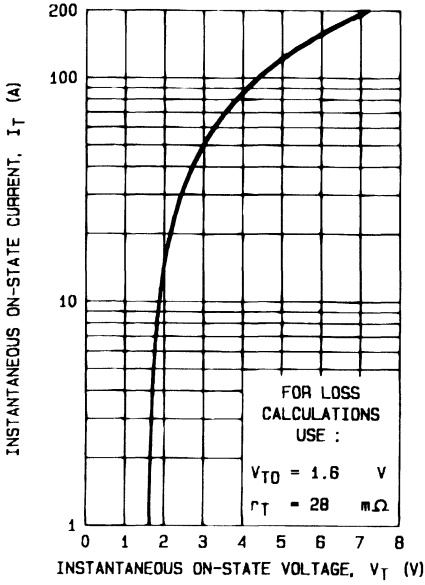

FIG.7 - MAXIMUM ON-STATE CONDUCTION CHARACTERISTIC ( $T_J = 125^\circ\text{C}$ ).

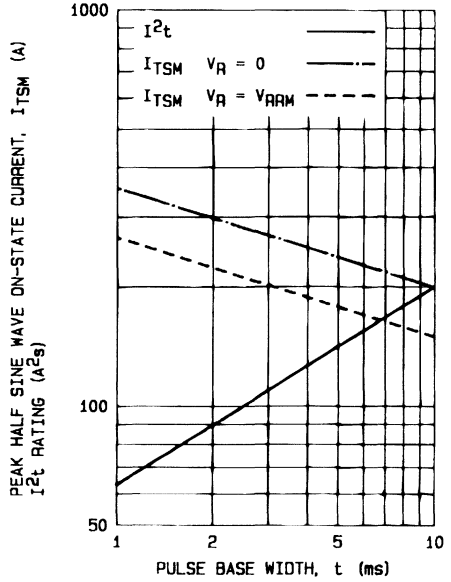

FIG.8 - NON REPETITIVE SUB-CYCLE SURGE ON-STATE CURRENT AND  $I^2t$  RATING (INITIAL  $T_J = 125^\circ\text{C}$ ).

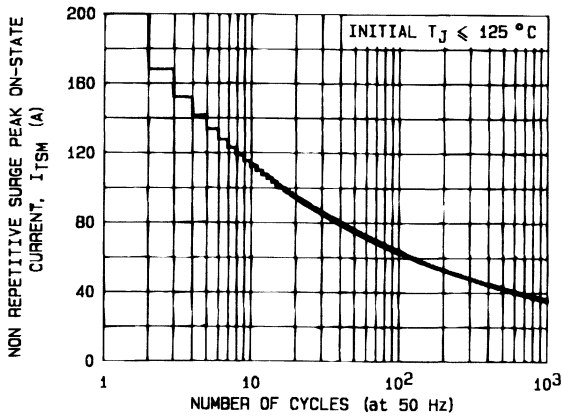
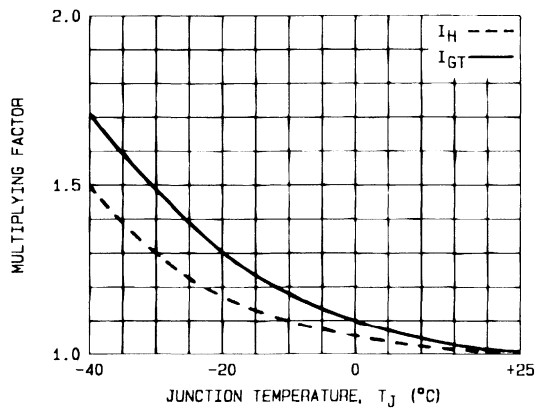
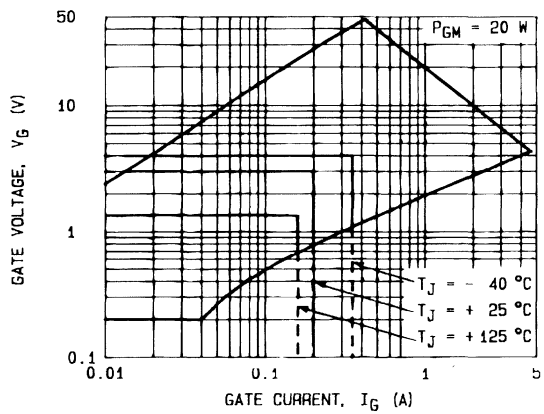

FIG.9 - NON REPETITIVE SURGE PEAK ON-STATE CURRENT VERSUS NUMBER OF CYCLES.



**FIG. 10 - RELATIVE VARIATION OF GATE TRIGGER CURRENT AND HOLDING CURRENT VERSUS JUNCTION TEMPERATURE.**



**FIG. 11 - GATE TRIGGER CHARACTERISTICS.**

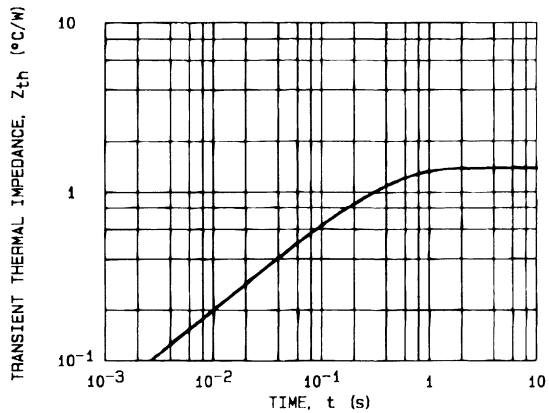
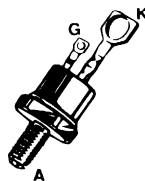

**FIG. 12 - TRANSIENT THERMAL IMPEDANCE JUNCTION TO CASE.**

**THYRISTORS**

- GLASS PASSIVATED CHIP
- HIGH STABILITY AND RELIABILITY

Thread : 1/4" -28 UNF : type N°  
 M6 on request : type N° + suffix M



**TO 48**  
(Metal)

**DESCRIPTION**

General purpose SCR suited for power supplies up to 400 Hz on resistive or inductive loads.

**ABSOLUTE RATINGS** (limiting values)

Symbol	Parameter	Value	Unit
$I_{T(RMS)}$	RMS on-state Current (1)	$T_c = 75^\circ\text{C}$ 25	A
$I_{T(AV)}$	Mean on-state Current (1)	$T_c = 75^\circ\text{C}$ 16	A
$I_{TSM}$	Non Repetitive Surge Peak on-state Current ( $T_j$ initial $\leq 125^\circ\text{C}$ ) (2)	$t = 8.3$ ms	210
		$t = 10$ ms	200
$I^2t$	$I^2t$ Value for Fusing	$t = 10$ ms	200
$di/dt$	Critical Rate of Rise of on-state Current (3)	100	A/ $\mu\text{s}$
$T_{stg}$	Storage and Operating Junction Temperature Range	- 40 to 150	$^\circ\text{C}$
$T_j$		- 40 to 125	$^\circ\text{C}$

Symbol	Parameter	BTW39-												Unit	
		50	100	200	300	400	500	600	700	800	900	1000	1100		1200
$V_{DRM}$ $V_{RRM}$	Repetitive Peak off-state Voltage (4)	50	100	200	300	400	500	600	700	800	900	1000	1100	1200	V

(1) Single phase circuit,  $180^\circ$  conduction angle.

(2) Half sine wave.

(3)  $I_G = 0.8$  A  $di/dt = 1$  A/ $\mu\text{s}$ .

(4)  $T_j = 125^\circ\text{C}$ .

**THERMAL RESISTANCES**

Symbol	Parameter	Value	Unit
$R_{th(j-c)}$	Junction-case for D.C.	1.42	$^\circ\text{C/W}$
$R_{th(c-h)}$	Contact (case to heatsink)	0.4	$^\circ\text{C/W}$

**GATE CHARACTERISTICS** (maximum values)

$P_{GM} = 20 \text{ W}$  ( $t_p = 100 \mu\text{s}$ )       $I_{FGM} = 8 \text{ A}$  ( $t_p = 100 \mu\text{s}$ )       $V_{RGM} = 5 \text{ V}$   
 $P_{G(AV)} = 1 \text{ W}$        $V_{FGM} = 15 \text{ V}$  ( $t_p = 100 \mu\text{s}$ )

**ELECTRICAL CHARACTERISTICS**

Symbol	Test Conditions			Min.	Typ.	Max.	Unit
$I_{GT}$	$T_j = 25 \text{ }^\circ\text{C}$ Pulse Duration > 20 $\mu\text{s}$	$V_D = 12 \text{ V}$	$R_L = 33 \text{ } \Omega$		50	80	mA
$V_{GT}$	$T_j = 25 \text{ }^\circ\text{C}$ Pulse Duration > 20 $\mu\text{s}$	$V_D = 12 \text{ V}$	$R_L = 33 \text{ } \Omega$			1.5	V
$V_{GD}$	$T_j = 125 \text{ }^\circ\text{C}$	$V_D = V_{DRM}$	$R_L = 3.3 \text{ k}\Omega$	0.2			V
$I_H$	$T_j = 25 \text{ }^\circ\text{C}$	$I_T = 0.5 \text{ A}$	Gate Open		20		mA
$I_L$	$T_j = 25 \text{ }^\circ\text{C}$ Pulse Duration > 20 $\mu\text{s}$	$V_D = 12 \text{ V}$	$I_G = 160 \text{ mA}$		40		mA
$V_{TM}$	$T_j = 25 \text{ }^\circ\text{C}$	$I_{TM} = 50 \text{ A}$	$t_p = 10 \text{ ms}$			2.2	V
$I_{DRM}$	$V_{DRM}$ Specified		$T_j = 25 \text{ }^\circ\text{C}$			0.02	mA
			$T_j = 125 \text{ }^\circ\text{C}$			5	
$I_{RRM}$	$V_{RRM}$ Specified		$T_j = 25 \text{ }^\circ\text{C}$			0.02	mA
			$T_j = 125 \text{ }^\circ\text{C}$			5	
$t_{gt}$	$T_j = 25 \text{ }^\circ\text{C}$ $I_G = 200 \text{ mA}$	$V_D = V_{DRM}$ $di_G/dt = 2 \text{ A}/\mu\text{s}$	$I_T = 50 \text{ A}$		2		$\mu\text{s}$
$t_q$	$T_j = 125 \text{ }^\circ\text{C}$ $V_D = 67 \% V_{DRM}$ Gate Open	$I_T = 50 \text{ A}$ $di/dt = 30 \text{ A}/\mu\text{s}$	$V_R = 50 \text{ V}$ $dv/dt = 20 \text{ V}/\mu\text{s}$		100		$\mu\text{s}$
$dv/dt^*$	$T_j = 125 \text{ }^\circ\text{C}$ Linear Slope up to $V_D = 67 \% V_{DRM}$	Gate Open		200	400		V/ $\mu\text{s}$

\* For higher guaranteed values, please consult us.

**PACKAGE MECHANICAL DATA : TO 48 Metal**

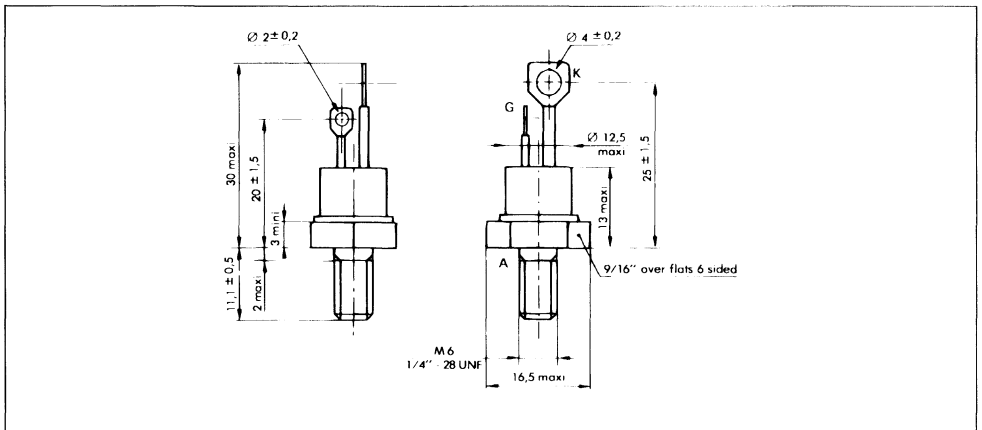

Cooling method : by conduction (method C)  
 Marking : type number  
 Weight :  $13.5 \pm 1 \text{ g}$   
 Polarity : anode to case  
 Stud torque :  $3.5 \text{ m}\cdot\text{N}$  min -  $3.8 \text{ m}\cdot\text{N}$  max.



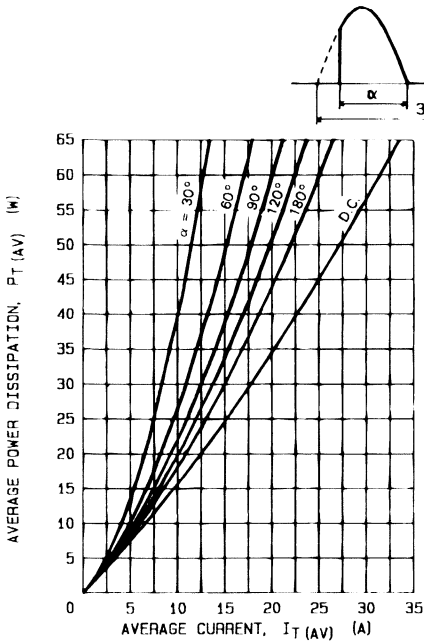

FIG. 1 - MAXIMUM ON-STATE POWER DISSIPATION FOR SINUSOIDAL CURRENT WAVEFORM

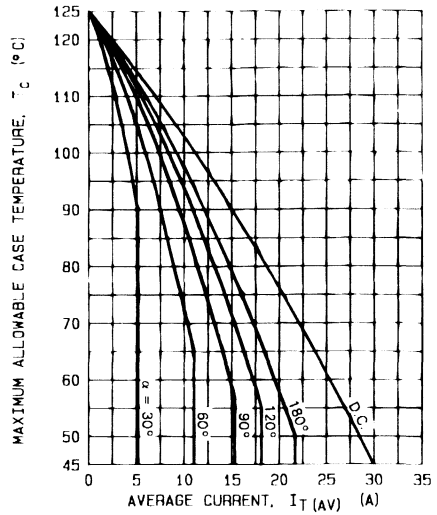

FIG. 2 - MAXIMUM ALLOWABLE CASE TEMPERATURE FOR SINUSOIDAL CURRENT WAVEFORM

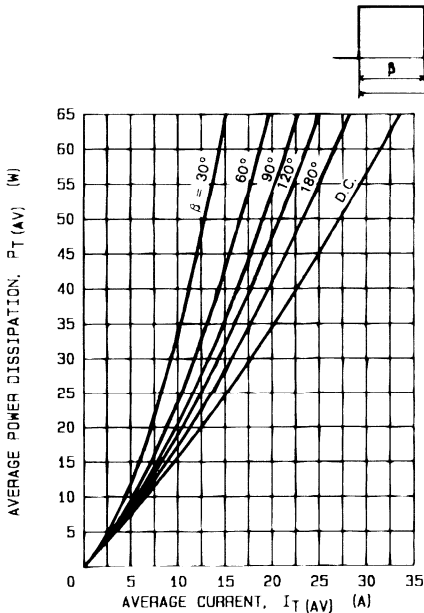

FIG. 3 - MAXIMUM ON-STATE POWER DISSIPATION FOR RECTANGULAR CURRENT WAVEFORM

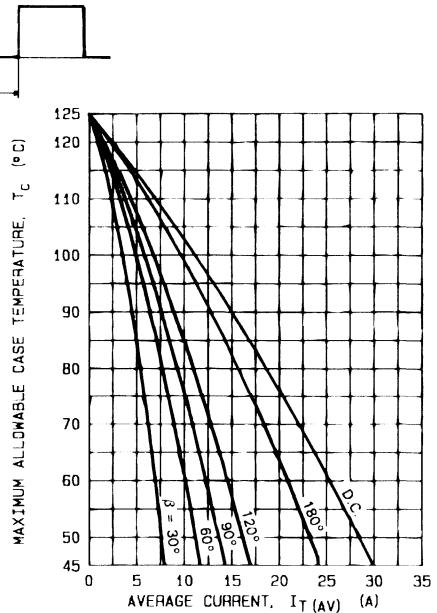

FIG. 4 - MAXIMUM ALLOWABLE CASE TEMPERATURE FOR RECTANGULAR CURRENT WAVEFORM

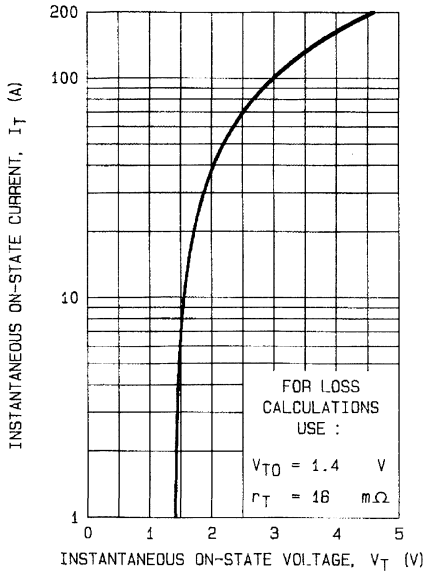

FIG.5 - MAXIMUM ON-STATE CONDUCTION CHARACTERISTIC ( $T_J = 125^\circ\text{C}$ ).

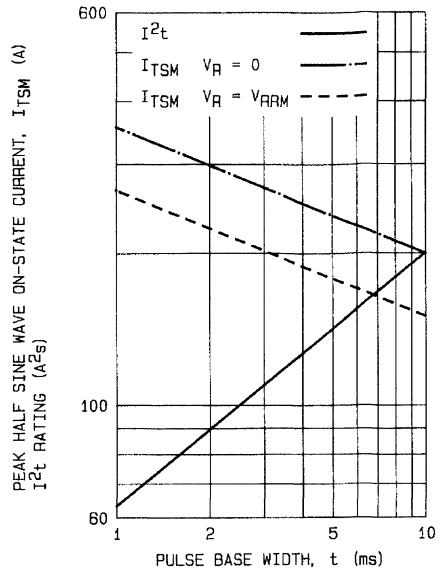

FIG.6 - NON REPETITIVE SUB-CYCLE SURGE ON-STATE CURRENT AND  $I^2t$  RATING (INITIAL  $T_J = 125^\circ\text{C}$ ).

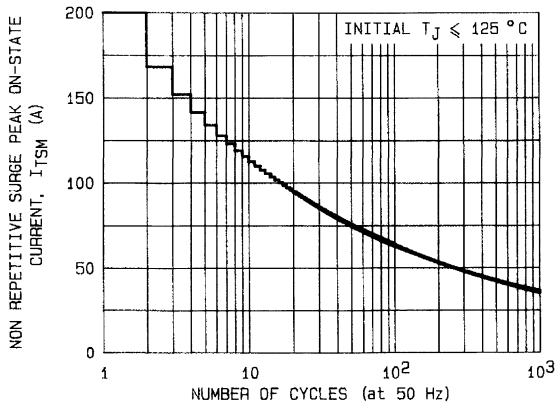

FIG.7 - NON REPETITIVE SURGE PEAK ON-STATE CURRENT VERSUS NUMBER OF CYCLES.

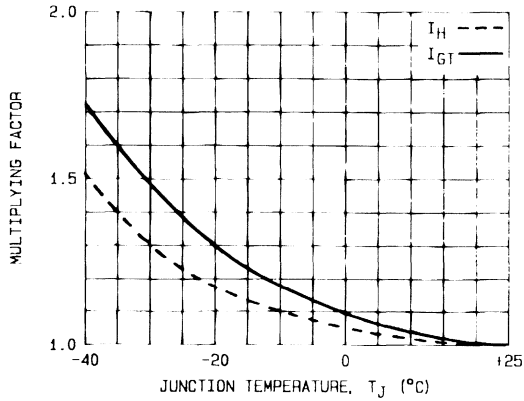

FIG.8 - RELATIVE VARIATION OF GATE TRIGGER CURRENT AND HOLDING CURRENT VERSUS JUNCTION TEMPERATURE.

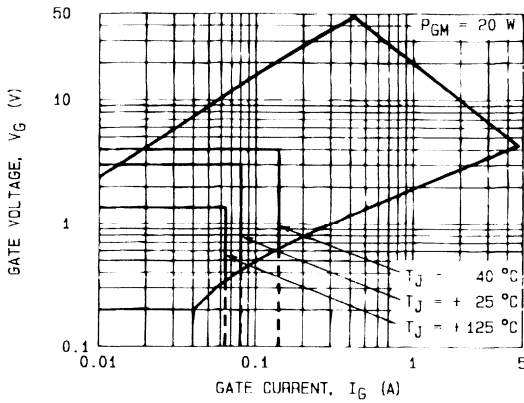
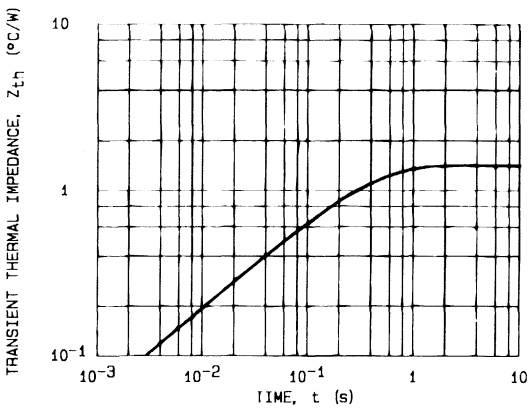

FIG.8 - GATE TRIGGER CHARACTERISTICS.



Conduction angle ( $\alpha, \beta$ )	Effective thermal resistance ( $^{\circ}\text{C}/\text{W}$ ) junction to case	
	Sinusoidal	Rectangular
180°	1.53	1.51
120°	1.59	2.13
90°	1.70	2.41
60°	1.99	2.70
30°	2.56	3.41

FIG.10 - TRANSIENT THERMAL IMPEDANCE JUNCTION TO CASE.



**THYRISTORS**

- GLASS PASSIVATED CHIP
- HIGH STABILITY AND RELIABILITY
- HIGH SURGE CAPABILITY

Thread : 1/4" -28 UNF : type N<sup>o</sup>  
 M6 on request : type N<sup>o</sup> + suffix M



**TO 48**  
(Metal)

**DESCRIPTION**

General purpose SCR suited for power supplies up to 400 Hz on resistive or inductive loads.

**ABSOLUTE RATINGS** (limiting values)

Symbol	Parameter	Value	Unit
$i_{T(RMS)}$	RMS on-state Current (1)	$T_c = 85\text{ }^\circ\text{C}$ 50	A
$I_{T(AV)}$	Mean on-state Current (1)	$T_c = 85\text{ }^\circ\text{C}$ 32	A
$I_{TSM}$	Non Repetitive Surge Peak on-state Current ( $T_j$ initial $\leq 125\text{ }^\circ\text{C}$ ) (2)	$t = 8.3\text{ ms}$	520
		$t = 10\text{ ms}$	500
$I^2t$	$I^2t$ Value for Fusing	$t = 10\text{ ms}$ 1250	A <sup>2</sup> s
di/dt	Critical Rate of Rise of on-state Current (3)	100	A/ $\mu$ s
$T_{stg}$ $T_j$	Storage and Operating Junction Temperature Range	- 40 to 150 - 40 to 125	$^\circ\text{C}$ $^\circ\text{C}$

Symbol	Parameter	BTW48-					Unit
		200	400	600	800	1200	
$V_{DRM}$ $V_{RRM}$	Repetitive Peak off-state Voltage (4)	200	400	600	800	1200	V

(1) Single phase circuit, 180° conduction angle.

(2) Half sine wave.

(3)  $I_G = 0.6\text{ A}$  di/dt = 1 A/ $\mu$ s.

(4)  $T_j = 125\text{ }^\circ\text{C}$ .

**THERMAL RESISTANCES**

Symbol	Parameter	Value	Unit
$R_{th(j-c)}$	Junction-case for D.C.	0.7	$^\circ\text{C}/\text{W}$
$R_{th(c-h)}$	Contact (case to heatsink)	0.4	$^\circ\text{C}/\text{W}$

**GATE CHARACTERISTICS** (maximum values)

$P_{GM} = 60 \text{ W}$  ( $t_p = 500 \mu\text{s}$ )       $I_{FGM} = 10 \text{ A}$  ( $t_p = 500 \mu\text{s}$ )       $V_{RGM} = 5 \text{ V}$   
 $P_{G(AV)} = 1 \text{ W}$        $V_{FGM} = 15 \text{ V}$  ( $t_p = 500 \mu\text{s}$ )

**ELECTRICAL CHARACTERISTICS**

Symbol	Test Conditions			Min.	Typ.	Max.	Unit
$I_{GT}$	$T_j = 25 \text{ }^\circ\text{C}$ Pulse Duration > 20 $\mu\text{s}$	$V_D = 12 \text{ V}$	$R_L = 33 \text{ }\Omega$		30	60	mA
$V_{GT}$	$T_j = 25 \text{ }^\circ\text{C}$ Pulse Duration > 20 $\mu\text{s}$	$V_D = 12 \text{ V}$	$R_L = 33 \text{ }\Omega$			1.5	V
$V_{GD}$	$T_j = 125 \text{ }^\circ\text{C}$	$V_D = V_{DRM}$	$R_L = 3.3 \text{ k}\Omega$	0.2			V
$I_H$	$T_j = 25 \text{ }^\circ\text{C}$	$I_T = 0.5 \text{ A}$	Gate Open		30		mA
$I_L$	$T_j = 25 \text{ }^\circ\text{C}$ Pulse Duration > 20 $\mu\text{s}$	$V_D = 12 \text{ V}$	$I_G = 120 \text{ mA}$		60		mA
$V_{TM}$	$T_j = 25 \text{ }^\circ\text{C}$	$I_{TM} = 100 \text{ A}$	$t_p = 10 \text{ ms}$			1.8	V
$I_{DRM}$	$V_{DRM}$ Specified			$T_j = 25 \text{ }^\circ\text{C}$		0.02	mA
				$T_j = 125 \text{ }^\circ\text{C}$		5	
$I_{RRM}$	$V_{RRM}$ Specified			$T_j = 25 \text{ }^\circ\text{C}$		0.02	mA
				$T_j = 125 \text{ }^\circ\text{C}$		5	
$t_{gt}$	$T_j = 25 \text{ }^\circ\text{C}$ $I_G = 200 \text{ mA}$	$V_D = V_{DRM}$ $di_G/dt = 2 \text{ A}/\mu\text{s}$	$I_T = 100 \text{ A}$		2		$\mu\text{s}$
$t_q$	$T_j = 125 \text{ }^\circ\text{C}$ $V_D = 67 \% V_{DRM}$ Gate Open	$I_T = 100 \text{ A}$ $di/dt = 30 \text{ A}/\mu\text{s}$	$V_R = 50 \text{ V}$ $dv/dt = 20 \text{ V}/\mu\text{s}$		100		$\mu\text{s}$
$dv/dt^*$	$T_j = 125 \text{ }^\circ\text{C}$	Gate Open Linear Slope up to $V_D = 67 \% V_{DRM}$		200			V/ $\mu\text{s}$

\* For higher guaranteed values, please consult us.

**PACKAGE MECHANICAL DATA : TO 48 Metal**

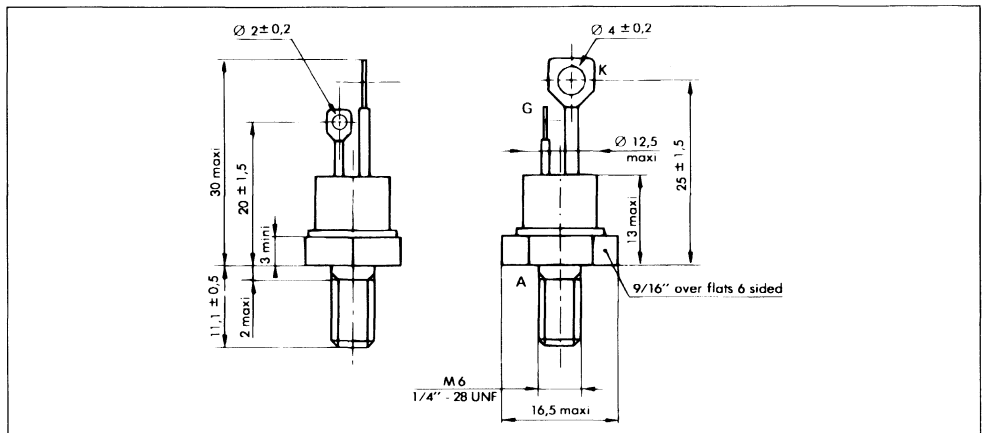

Cooling method : by conduction (method C)  
 Marking : type number  
 Weight :  $13,5 \pm 1 \text{ g}$   
 Polarity : anode to case  
 Stud torque : 3.5 mAN min - 3.8 mAN max.

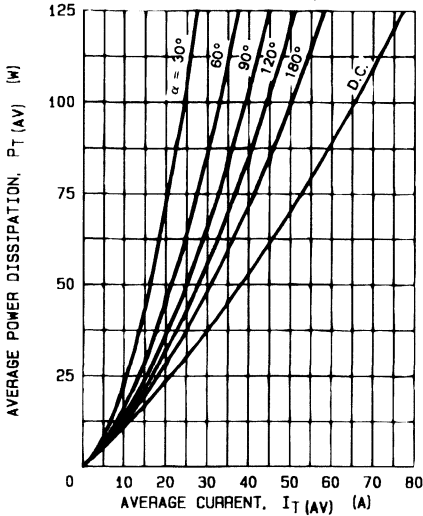
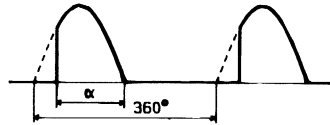

FIG.1 - MAXIMUM ON-STATE POWER DISSIPATION FOR SINUSOIDAL CURRENT WAVEFORM

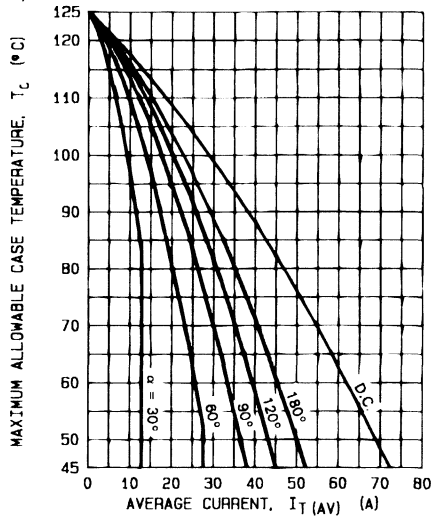

FIG.2 - MAXIMUM ALLOWABLE CASE TEMPERATURE FOR SINUSOIDAL CURRENT WAVEFORM

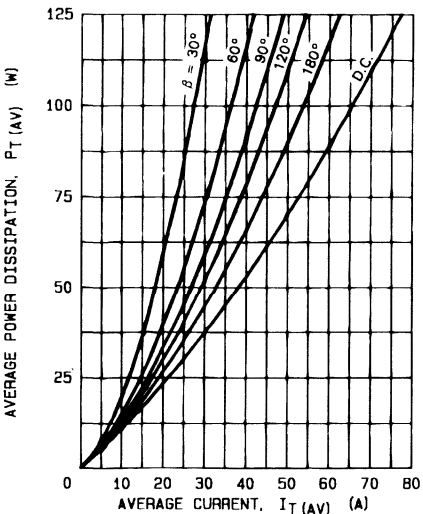
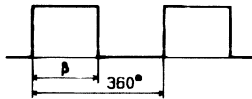

FIG.3 - MAXIMUM ON-STATE POWER DISSIPATION FOR RECTANGULAR CURRENT WAVEFORM

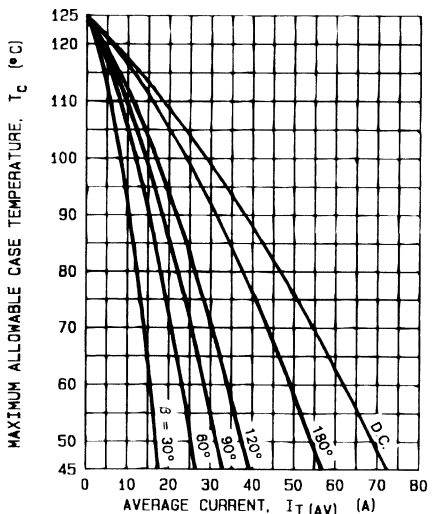

FIG.4 - MAXIMUM ALLOWABLE CASE TEMPERATURE FOR RECTANGULAR CURRENT WAVEFORM

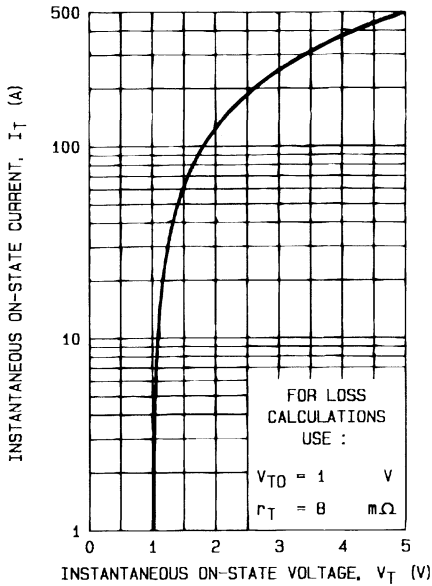

FIG.5 - MAXIMUM ON-STATE CONDUCTION CHARACTERISTIC ( $T_J = 125^\circ\text{C}$ ).

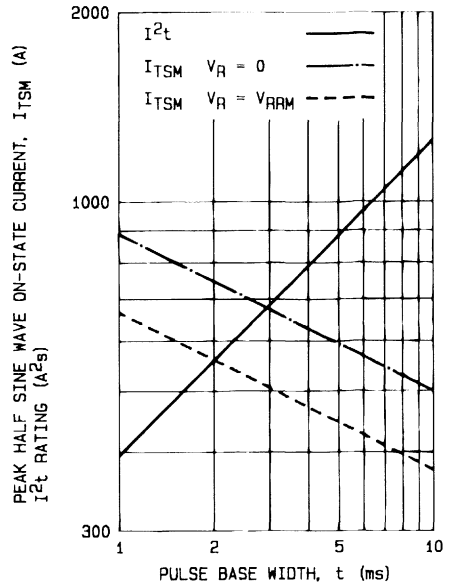

FIG.6 - NON REPETITIVE SUB-CYCLE SURGE ON-STATE CURRENT AND  $I^2t$  RATING (INITIAL  $T_J = 125^\circ\text{C}$ ).

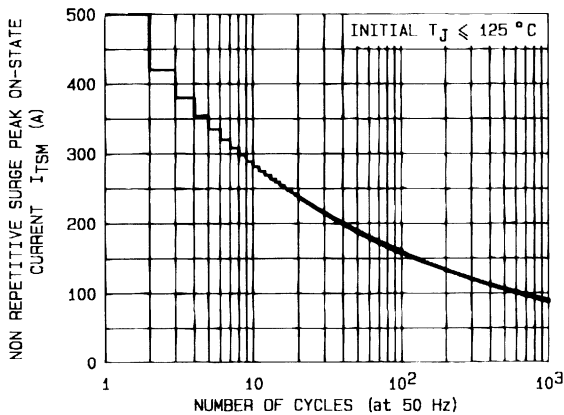

FIG.7 - NON REPETITIVE SURGE PEAK ON-STATE CURRENT VERSUS NUMBER OF CYCLES.



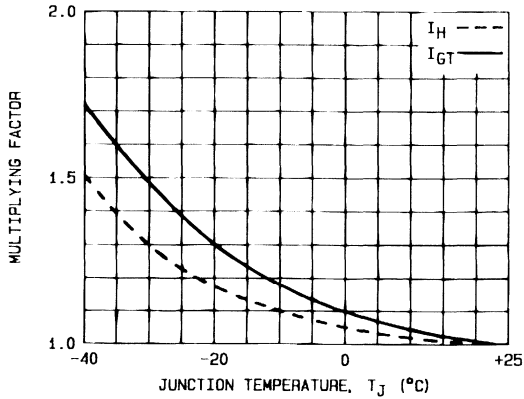

FIG.8 - RELATIVE VARIATION OF GATE TRIGGER CURRENT AND HOLDING CURRENT VERSUS JUNCTION TEMPERATURE.

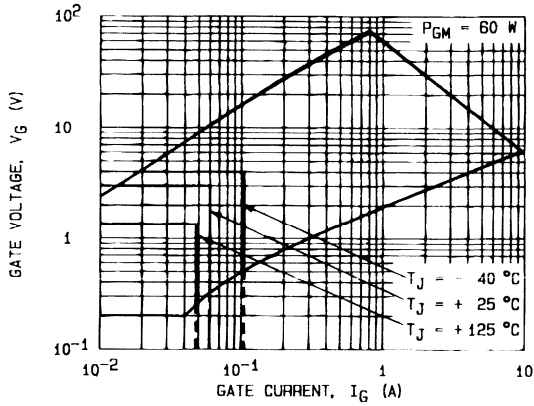
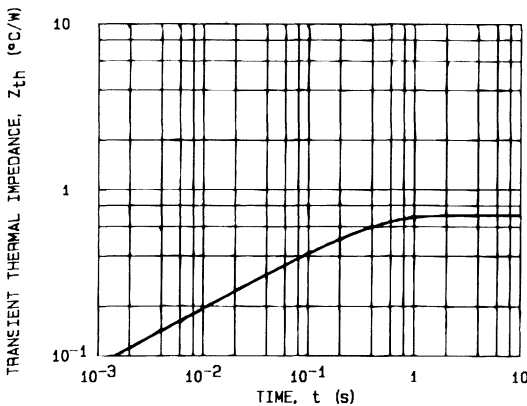

FIG.9 - GATE TRIGGER CHARACTERISTICS.



Conduction angle ( $\alpha, \beta$ )	Effective thermal resistance ( $^{\circ}\text{C}/\text{W}$ ) junction to case	
	Sinusoidal	Rectangular
180°	0.76	0.74
120°	0.78	1.05
90°	0.84	1.19
60°	0.98	1.33
30°	1.26	1.68

FIG.10 - TRANSIENT THERMAL IMPEDANCE JUNCTION TO CASE.



**THYRISTORS**

- GLASS PASSIVATED CHIP
- HIGH STABILITY AND RELIABILITY
- HIGH SURGE CAPABILITY

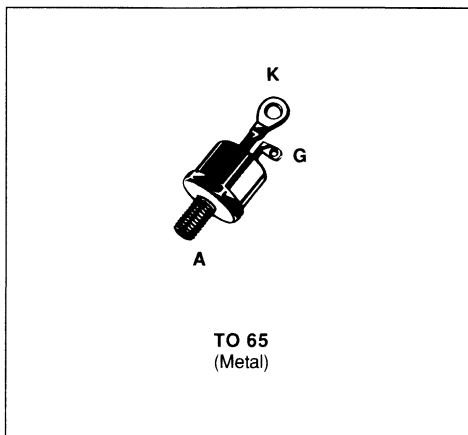
**DESCRIPTION**

General purpose SCR suited for power supplies up to 400 Hz on resistive or inductive loads.

**ABSOLUTE RATINGS** (limiting values)

Symbol	Parameter		Value	Unit
$I_{T(RMS)}$	RMS on-state Current (1)	$T_c = 105^\circ\text{C}$	63	A
$I_{T(AV)}$	Mean on-state Current (1)	$T_c = 105^\circ\text{C}$	40	A
$I_{TSM}$	Non Repetitive Surge Peak on-state Current ( $T_j$ initial $\leq 125^\circ\text{C}$ ) (2)	$t = 8.3$ ms	950	A
		$t = 10$ ms	910	
$I^2t$	$I^2t$ Value for Fusing	$t = 10$ ms	4150	$\text{A}^2\text{s}$
$di/dt$	Critical Rate of Rise of on-state Current (3)		100	$\text{A}/\mu\text{s}$
$T_{stg}$ $T_j$	Storage and Operating Junction Temperature Range		- 40 to 150 - 40 to 125	$^\circ\text{C}$ $^\circ\text{C}$

Symbol	Parameter	BTW50-							Unit
		100	200	400	600	800	1000	1200	
$V_{DRM}$ $V_{RRM}$	Repetitive Peak off-state Voltage (4)	100	200	400	600	800	1000	1200	V

(1) Single phase circuit,  $180^\circ$  conduction angle.

(2) Half sine wave.

(3)  $I_G = 1.5$  A  $di/dt = 1$  A/ $\mu\text{s}$ .

(4)  $T_j = 125^\circ\text{C}$ .

**THERMAL RESISTANCES**

Symbol	Parameter	Value	Unit
$R_{th(j-c)}$	Junction-case for D.C.	0.36	$^\circ\text{C}/\text{W}$
$R_{th(c-h)}$	Contact (case to heatsink)	0.3	$^\circ\text{C}/\text{W}$

**GATE CHARACTERISTICS** (maximum values)

$P_{GM} = 80 \text{ W}$  ( $t_p = 500 \mu\text{s}$ )       $I_{FGM} = 10 \text{ A}$  ( $t_p = 500 \mu\text{s}$ )       $V_{RGM} = 5 \text{ V}$   
 $P_{G(AV)} = 2 \text{ W}$        $V_{FGM} = 15 \text{ V}$  ( $t_p = 500 \mu\text{s}$ )

**ELECTRICAL CHARACTERISTICS**

Symbol	Test Conditions			Min.	Typ.	Max.	Unit
$I_{GT}$	$T_j = 25 \text{ }^\circ\text{C}$ Pulse Duration > 20 $\mu\text{s}$	$V_D = 12 \text{ V}$	$R_L = 33 \text{ } \Omega$			150	mA
$V_{GT}$	$T_j = 25 \text{ }^\circ\text{C}$ Pulse Duration > 20 $\mu\text{s}$	$V_D = 12 \text{ V}$	$R_L = 33 \text{ } \Omega$			1.5	V
$V_{GD}$	$T_j = 125 \text{ }^\circ\text{C}$	$V_D = V_{DRM}$	$R_L = 3.3 \text{ k}\Omega$	0.2			V
$I_H$	$T_j = 25 \text{ }^\circ\text{C}$	$I_T = 0.5 \text{ A}$	Gate Open		50		mA
$I_L$	$T_j = 25 \text{ }^\circ\text{C}$ Pulse Duration > 20 $\mu\text{s}$	$V_D = 12 \text{ V}$	$I_G = 300 \text{ mA}$		100		mA
$V_{TM}$	$T_j = 25 \text{ }^\circ\text{C}$	$I_{TM} = 500 \text{ A}$	$t_p = 10 \text{ ms}$			3	V
$I_{DRM}$	$V_{DRM}$ Specified		$T_j = 25 \text{ }^\circ\text{C}$			0.02	mA
			$T_j = 125 \text{ }^\circ\text{C}$			12	
$I_{RRM}$	$V_{RRM}$ Specified		$T_j = 25 \text{ }^\circ\text{C}$			0.02	mA
			$T_j = 125 \text{ }^\circ\text{C}$			12	
$t_{gt}$	$T_j = 25 \text{ }^\circ\text{C}$ $I_G = 1 \text{ A}$	$V_D = V_{DRM}$ $di_G/dt = 10 \text{ A}/\mu\text{s}$	$I_T = 500 \text{ A}$		2		$\mu\text{s}$
$t_q$	$T_j = 125 \text{ }^\circ\text{C}$ $V_D = 67 \% V_{DRM}$ Gate Open	$I_T = 500 \text{ A}$ $di/dt = 30 \text{ A}/\mu\text{s}$	$V_R = 50 \text{ V}$ $dv/dt = 20 \text{ V}/\mu\text{s}$		100		$\mu\text{s}$
$dv/dt^*$	$T_j = 125 \text{ }^\circ\text{C}$ Linear Slope up to $V_D = 67 \% V_{DRM}$	Gate Open		200			V/ $\mu\text{s}$

\* For higher guaranteed values, please consult us.

**PACKAGE MECHANICAL DATA : TO 65 Metal**

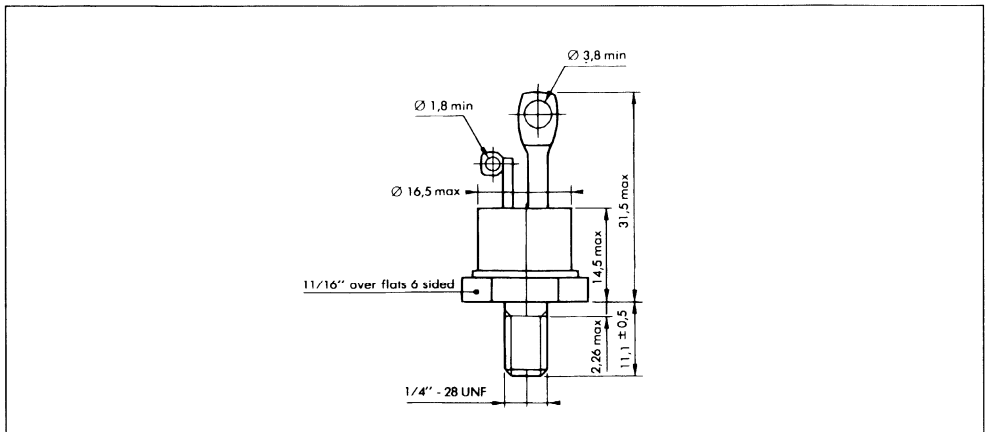

Cooling method : by conduction (method C)  
 Marking : type number  
 Weight : 19 g without accessories  
 Polarity : anode to case  
 Stud torque : 3.5 mAN min - 3.8 mAN max.

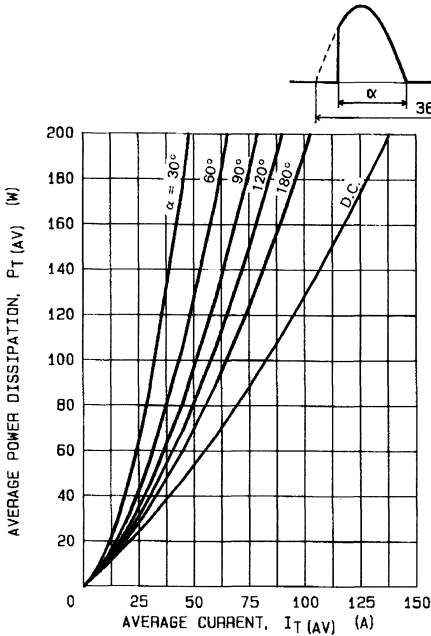

FIG.1 - MAXIMUM ON-STATE POWER DISSIPATION FOR SINUSOIDAL CURRENT WAVEFORM

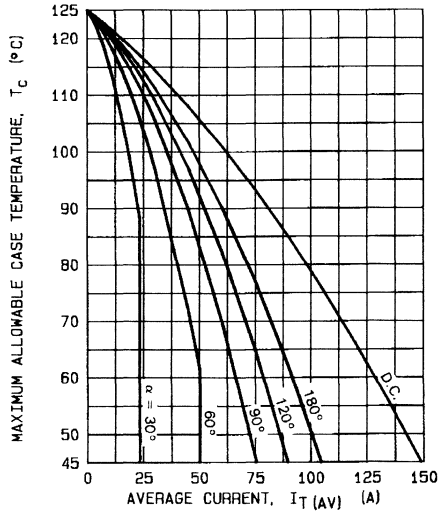

FIG.2 - MAXIMUM ALLOWABLE CASE TEMPERATURE FOR SINUSOIDAL CURRENT WAVEFORM

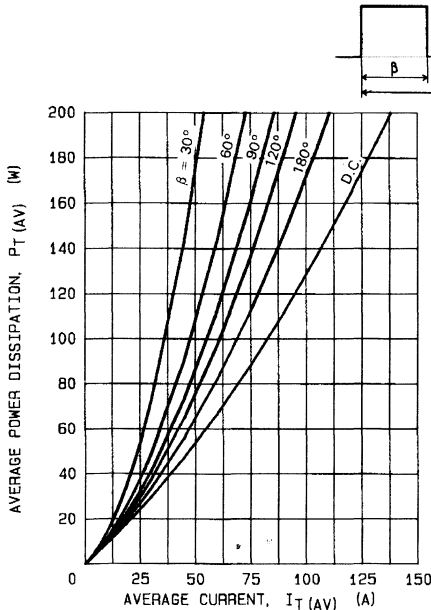

FIG.3 - MAXIMUM ON-STATE POWER DISSIPATION FOR RECTANGULAR CURRENT WAVEFORM

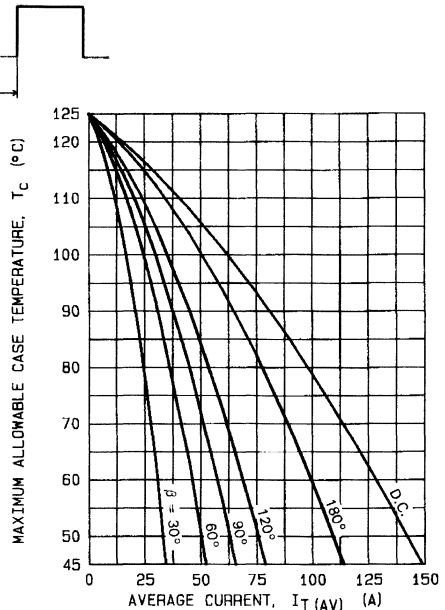

FIG.4 - MAXIMUM ALLOWABLE CASE TEMPERATURE FOR RECTANGULAR CURRENT WAVEFORM

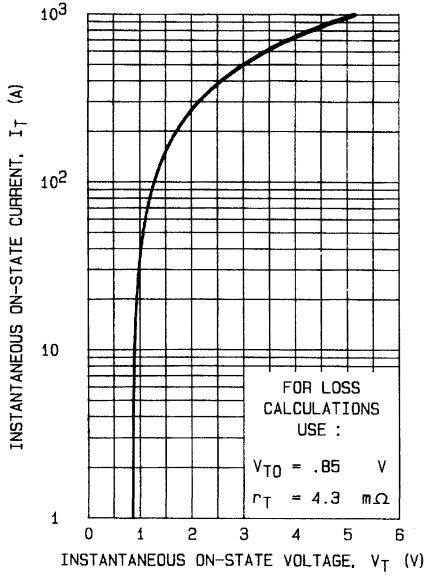

FIG.5 - MAXIMUM ON-STATE CONDUCTION CHARACTERISTIC ( $T_J = 125^\circ\text{C}$ ).

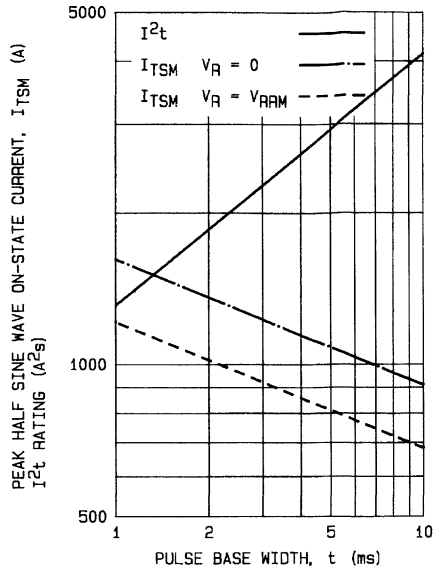

FIG.8 - NON REPETITIVE SUB-CYCLE SURGE ON-STATE CURRENT AND  $I^2t$  RATING (INITIAL  $T_J = 125^\circ\text{C}$ ).

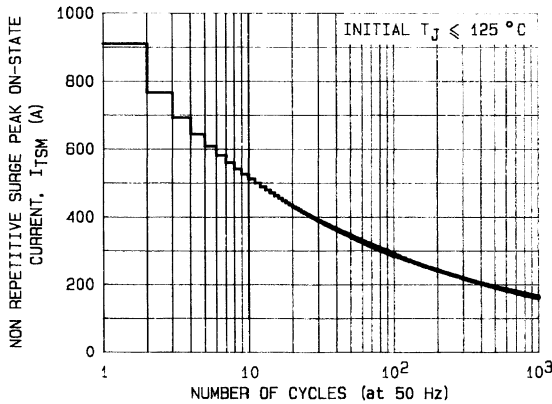

FIG.7 - NON REPETITIVE SURGE PEAK ON-STATE CURRENT VERSUS NUMBER OF CYCLES.

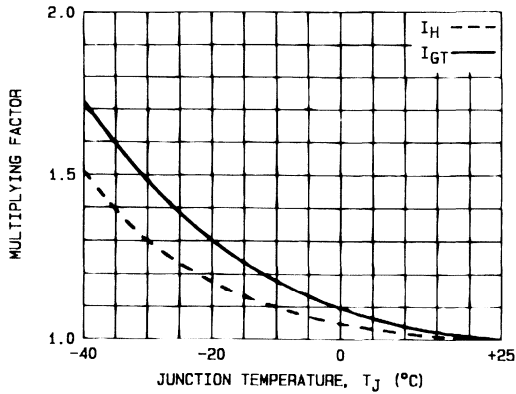

FIG.8 - RELATIVE VARIATION OF GATE TRIGGER CURRENT AND HOLDING CURRENT VERSUS JUNCTION TEMPERATURE.

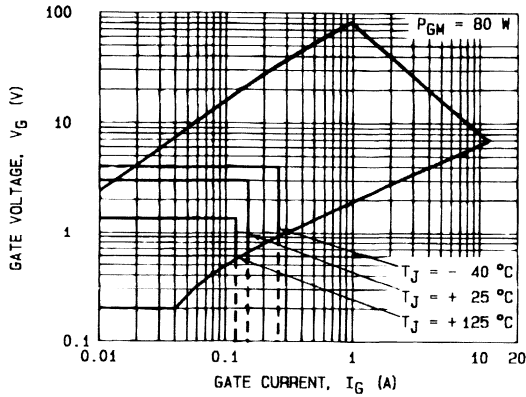
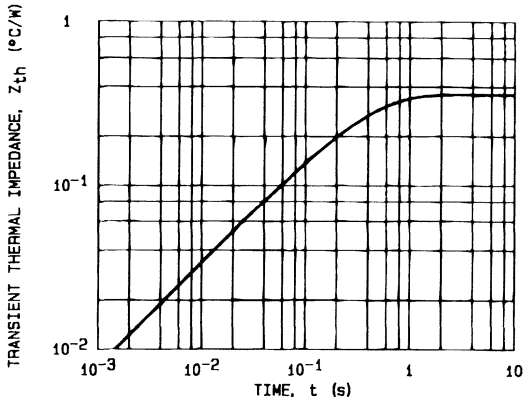

FIG.9 - GATE TRIGGER CHARACTERISTICS.



Conduction angle ( $\alpha, \beta$ )	Effective thermal resistance ( $^{\circ}\text{C}/\text{W}$ ) junction to case	
	Sinusoidal	Rectangular
180°	0.38	0.38
120°	0.40	0.54
90°	0.43	0.61
60°	0.50	0.68
30°	0.65	0.86

FIG.10 - TRANSIENT THERMAL IMPEDANCE JUNCTION TO CASE.





**THYRISTORS**

- GLASS PASSIVATED CHIP
- HIGH STABILITY AND RELIABILITY
- HIGH SURGE CAPABILITY
- EASY MOUNTING (FAST-ON CONNECTIONS)
- ISOLATED PACKAGE :  
INSULATING VOLTAGE 2500 V<sub>RMS</sub>
- UL RECOGNIZED (E81734)

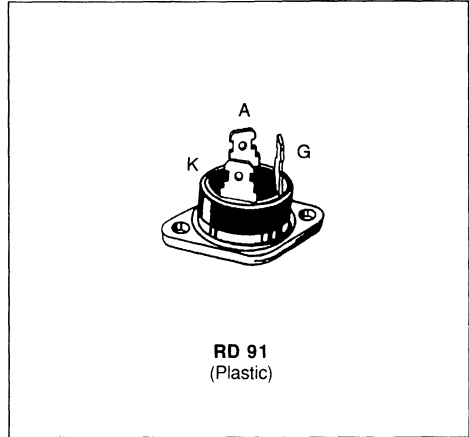
**DESCRIPTION**

General purpose SCR suited for power supplies up to 400 Hz on resistive or inductive loads.

**ABSOLUTE RATINGS** (limiting values)

Symbol	Parameter		Value	Unit
$I_{T(RMS)}$	RMS on-state Current (1)	$T_c = 65\text{ }^\circ\text{C}$	30	A
$I_{T(AV)}$	Mean on-state Current (1)	$T_c = 65\text{ }^\circ\text{C}$	20	A
$I_{TSM}$	Non Repetitive Surge Peak on-state Current ( $T_j$ initial = $25\text{ }^\circ\text{C}$ ) (2)	$t = 8.3\text{ ms}$	420	A
		$t = 10\text{ ms}$	400	
$I^2t$	$I^2t$ Value for Fusing	$t = 10\text{ ms}$	800	$\text{A}^2\text{s}$
$di/dt$	Critical Rate of Rise of on-state Current (3)		100	$\text{A}/\mu\text{s}$
$T_{stg}$ $T_j$	Storage and Operating Junction Temperature Range		- 40 to 125 - 40 to 110	$^\circ\text{C}$ $^\circ\text{C}$

Symbol	Parameter	BTW66-						Unit
		200	400	600	800	1000	1200	
$V_{DRM}$ $V_{RRM}$	Repetitive Peak off-state Voltage (4)	200	400	600	800	1000	1200	V

(1) Single phase circuit,  $180^\circ$  conduction angle.

(2) Half sine wave.

(3)  $I_G = 500\text{ mA}$   $di_G/dt = 1\text{ A}/\mu\text{s}$ .

(4)  $T_j = 110\text{ }^\circ\text{C}$ .

**THERMAL RESISTANCES**

Symbol	Parameter	Value	Unit
$R_{th(j-c)}$	Junction-case for D.C.	1.02	$^\circ\text{C}/\text{W}$
$R_{th(c-h)}$	Contact (case to heatsink)	0.10	$^\circ\text{C}/\text{W}$

**GATE CHARACTERISTICS** (maximum values)

$P_{GM} = 50 \text{ W}$  ( $t_p = 10 \mu\text{s}$ )       $I_{FGM} = 2 \text{ A}$  ( $t_p = 10 \mu\text{s}$ )       $V_{RGM} = 5 \text{ V}$   
 $P_{G(AV)} = 1 \text{ W}$        $V_{FGM} = 15 \text{ V}$  ( $t_p = 10 \mu\text{s}$ )

**ELECTRICAL CHARACTERISTICS**

Symbol	Test Conditions			Min.	Typ.	Max.	Unit
$I_{GT}$	$T_j = 25 \text{ }^\circ\text{C}$ Pulse Duration > 20 $\mu\text{s}$	$V_D = 12 \text{ V}$	$R_L = 33 \text{ } \Omega$			50	mA
$V_{GT}$	$T_j = 25 \text{ }^\circ\text{C}$ Pulse Duration > 20 $\mu\text{s}$	$V_D = 12 \text{ V}$	$R_L = 33 \text{ } \Omega$			1.5	V
$V_{GD}$	$T_j = 110 \text{ }^\circ\text{C}$	$V_D = V_{DRM}$	$R_L = 3.3 \text{ k}\Omega$	0.2			V
$I_H$	$T_j = 25 \text{ }^\circ\text{C}$	$I_T = 0.5 \text{ A}$	Gate Open		20	75	mA
$I_L$	$T_j = 25 \text{ }^\circ\text{C}$ Pulse Duration > 20 $\mu\text{s}$	$V_D = 12 \text{ V}$	$I_G = 100 \text{ mA}$		40		mA
$V_{TM}$	$T_j = 25 \text{ }^\circ\text{C}$	$I_{TM} = 60 \text{ A}$	$t_p = 10 \text{ ms}$			2.2	V
$I_{DRM}$	$V_{DRM}$ Specified			$T_j = 25 \text{ }^\circ\text{C}$		0.02	mA
				$T_j = 110 \text{ }^\circ\text{C}$		3	
$I_{RRM}$	$V_{RRM}$ Specified			$T_j = 25 \text{ }^\circ\text{C}$		0.02	mA
				$T_j = 110 \text{ }^\circ\text{C}$		3	
$t_{gt}$	$T_j = 25 \text{ }^\circ\text{C}$ $I_G = 200 \text{ mA}$	$V_D = V_{DRM}$ $di_G/dt = 0.2 \text{ A}/\mu\text{s}$	$I_T = 60 \text{ A}$		2		$\mu\text{s}$
$t_q$	$T_j = 110 \text{ }^\circ\text{C}$ $V_D = 67 \% V_{DRM}$ Gate Open	$I_T = 60 \text{ A}$ $di/dt = 30 \text{ A}/\mu\text{s}$	$V_R = 75 \text{ V}$ $dv/dt = 20 \text{ V}/\mu\text{s}$		100		$\mu\text{s}$
$dv/dt^*$	$T_j = 110 \text{ }^\circ\text{C}$ Gate Open Linear Slope up to $V_D = 67 \% V_{DRM}$			$V_{DRM} \leq 800 \text{ V}$	500		V/ $\mu\text{s}$
				$V_{DRM} \geq 1000 \text{ V}$	250		

\* For higher guaranteed values, please consult us.

**PACKAGE MECHANICAL DATA : RD 91 Plastic**

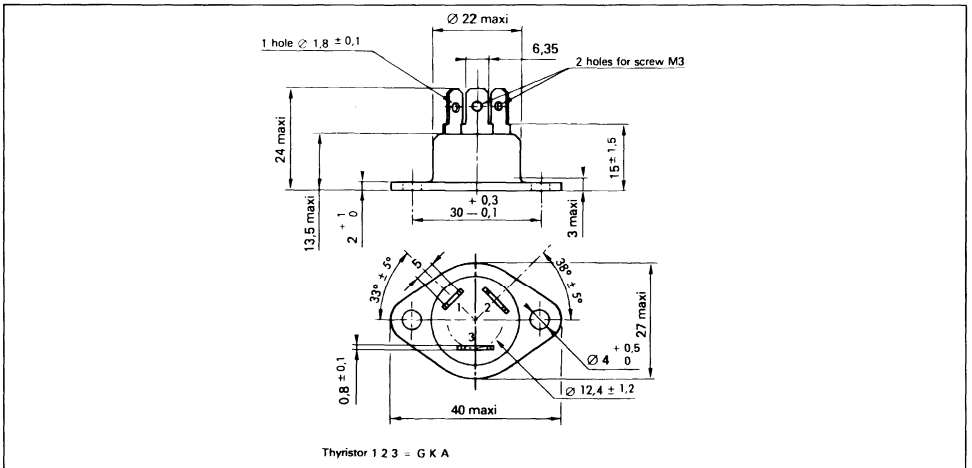

Cooling method : by conduction (method C)  
 Marking : type number  
 Weight : 15 g.

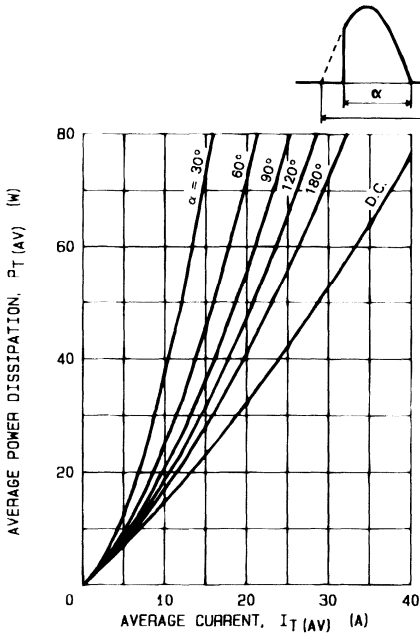

FIG.1 - MAXIMUM ON-STATE POWER DISSIPATION FOR SINUSOIDAL CURRENT WAVEFORM

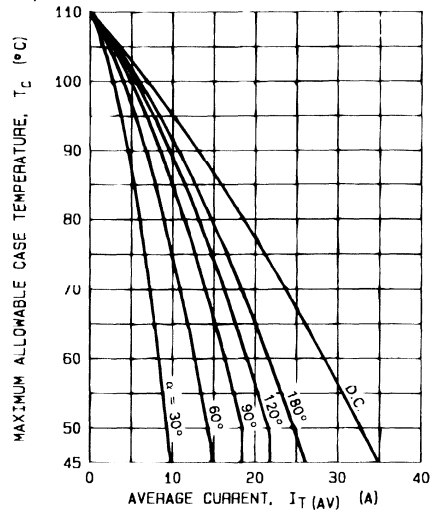

FIG.2 - MAXIMUM ALLOWABLE CASE TEMPERATURE FOR SINUSOIDAL CURRENT WAVEFORM

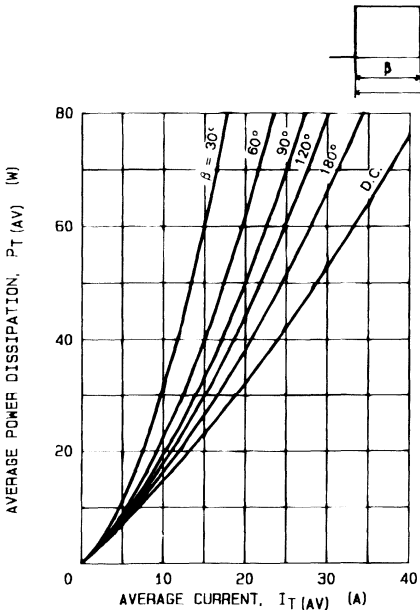

FIG.3 - MAXIMUM ON-STATE POWER DISSIPATION FOR RECTANGULAR CURRENT WAVEFORM

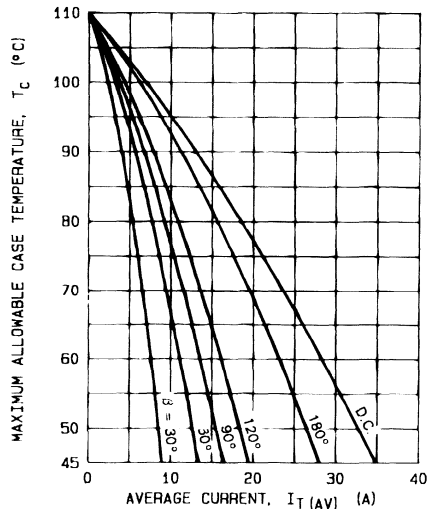

FIG.4 - MAXIMUM ALLOWABLE CASE TEMPERATURE FOR RECTANGULAR CURRENT WAVEFORM

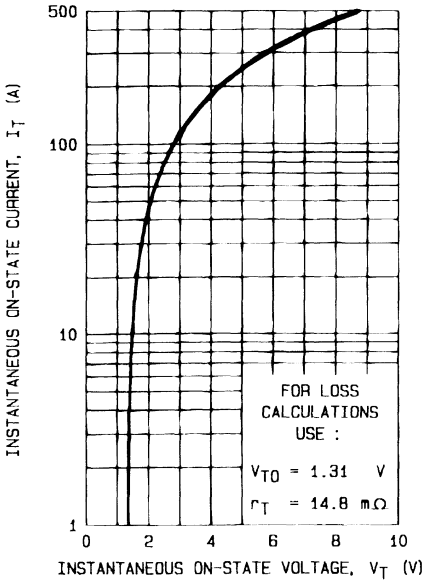

FIG.5 - MAXIMUM ON-STATE CONDUCTION CHARACTERISTIC ( $T_J = 110$  °C).

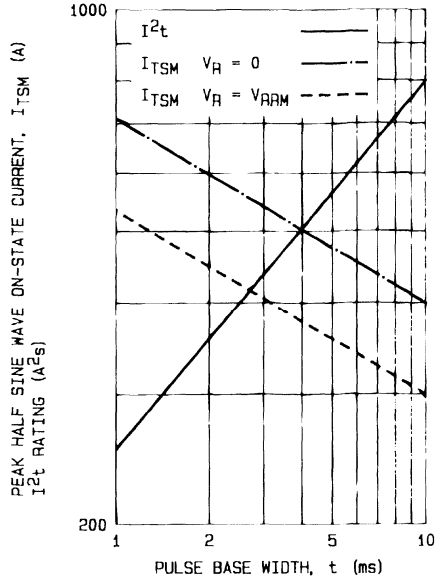

FIG.6 - NON REPETITIVE SUB-CYCLE SURGE ON-STATE CURRENT AND  $I^2t$  RATING (INITIAL  $T_J = 25$  °C).

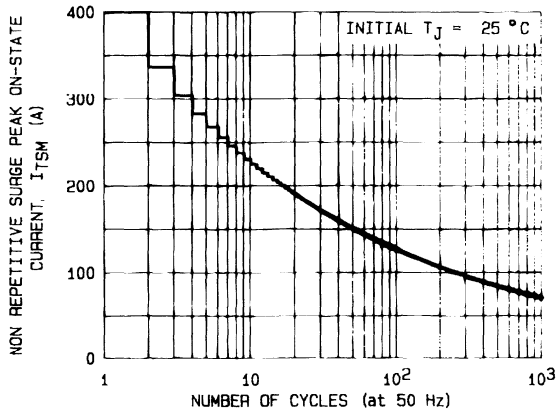

FIG.7 - NON REPETITIVE SURGE PEAK ON-STATE CURRENT VERSUS NUMBER OF CYCLES.

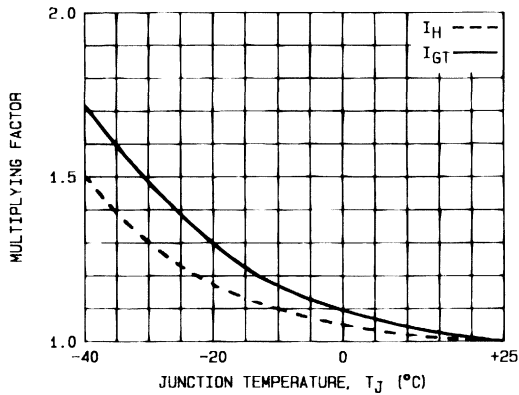

FIG.8 - RELATIVE VARIATION OF GATE TRIGGER CURRENT AND HOLDING CURRENT VERSUS JUNCTION TEMPERATURE.

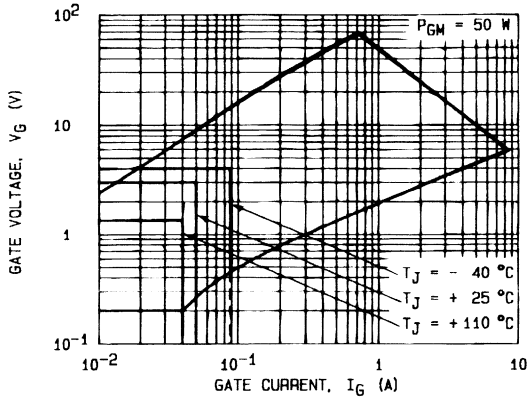
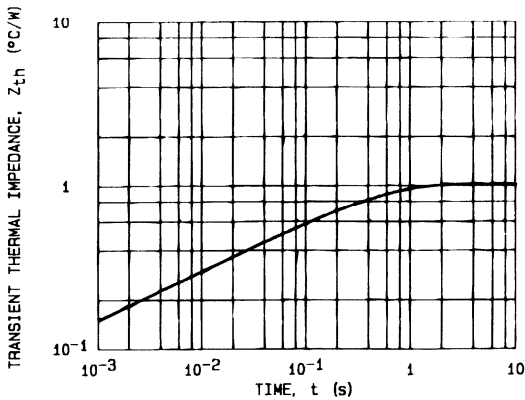

FIG.9 - GATE TRIGGER CHARACTERISTICS.



Conduction angle ( $\alpha, \beta$ )	Effective thermal resistance ( $^{\circ}\text{C}/\text{W}$ ) junction to case	
	Sinusoidal	Rectangular
180°	1.10	1.08
120°	1.14	1.53
90°	1.22	1.73
60°	1.43	1.94
30°	1.84	2.45

FIG.10 - TRANSIENT THERMAL IMPEDANCE JUNCTION TO CASE.



**THYRISTORS**

- GLASS PASSIVATED CHIP
- HIGH STABILITY AND RELIABILITY
- HIGH SURGE CAPABILITY
- HIGH ON-STATE CURRENT
- EASY MOUNTING (FAST-ON CONNECTIONS)
- ISOLATED PACKAGE :  
INSULATING VOLTAGE 2500 V<sub>RMS</sub>
- UL RECOGNIZED (E81734)

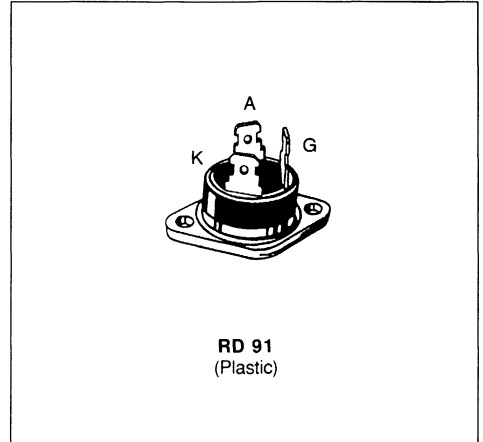

**DESCRIPTION**

General purpose SCR suited for power supplies up to 400 Hz on resistive or inductive loads.

**ABSOLUTE RATINGS** (limiting values)

Symbol	Parameter	Value	Unit	
$I_{T(RMS)}$	RMS on-state Current (1)	$T_c = 65\text{ }^\circ\text{C}$ 40	A	
$I_{T(AV)}$	Mean on-state Current (1)	$T_c = 65\text{ }^\circ\text{C}$ 25	A	
$I_{TSM}$	Non Repetitive Surge Peak on-state Current ( $T_j$ initial = $25\text{ }^\circ\text{C}$ ) (2)	$t = 8.3\text{ ms}$	525	A
		$t = 10\text{ ms}$	500	
$I^2t$	$I^2t$ Value for Fusing	$t = 10\text{ ms}$ 1250	$\text{A}^2\text{s}$	
$di/dt$	Critical Rate of Rise of on-state Current (3)	100	$\text{A}/\mu\text{s}$	
$T_{stg}$ $T_j$	Storage and Operating Junction Temperature Range	- 40 to 125	$^\circ\text{C}$	
		- 40 to 110	$^\circ\text{C}$	

Symbol	Parameter	BTW67-						Unit
		200	400	600	800	1000	1200	
$V_{DRM}$ $V_{RRM}$	Repetitive Peak off state Voltage (4)	200	400	600	800	1000	1200	V

- (1) Single phase circuit,  $180^\circ$  conduction angle.  
 (2) Half sine wave.  
 (3)  $I_G = 800\text{ mA}$   $di_G/dt = 1\text{ A}/\mu\text{s}$ .  
 (4)  $T_j = 110\text{ }^\circ\text{C}$ .

**THERMAL RESISTANCES**

Symbol	Parameter	Value	Unit
$R_{th(j-c)}$	Junction-case for D.C.	0.93	$^\circ\text{C}/\text{W}$
$R_{th(c-h)}$	Contact (case to heatsink)	0.10	$^\circ\text{C}/\text{W}$

**GATE CHARACTERISTICS** (maximum values)

$P_{GM} = 50 \text{ W}$  ( $t_p = 10 \mu\text{s}$ )       $I_{FGM} = 2 \text{ A}$  ( $t_p = 10 \mu\text{s}$ )       $V_{RGM} = 5 \text{ V}$   
 $P_{G(AV)} = 1 \text{ W}$        $V_{FGM} = 15 \text{ V}$  ( $t_p = 10 \mu\text{s}$ )

**ELECTRICAL CHARACTERISTICS**

Symbol	Test Conditions			Min.	Typ.	Max.	Unit
$I_{GT}$	$T_j = 25 \text{ }^\circ\text{C}$ Pulse Duration > 20 $\mu\text{s}$	$V_D = 12 \text{ V}$	$R_L = 33 \text{ } \Omega$			80	mA
$V_{GT}$	$T_j = 25 \text{ }^\circ\text{C}$ Pulse Duration > 20 $\mu\text{s}$	$V_D = 12 \text{ V}$	$R_L = 33 \text{ } \Omega$			1.5	V
$V_{GD}$	$T_j = 110 \text{ }^\circ\text{C}$	$V_D = V_{DRM}$	$R_L = 3.3 \text{ k}\Omega$	0.2			V
$I_H$	$T_j = 25 \text{ }^\circ\text{C}$	$I_T = 0.5 \text{ A}$	Gate Open		20	150	mA
$I_L$	$T_j = 25 \text{ }^\circ\text{C}$ Pulse Duration > 20 $\mu\text{s}$	$V_D = 12 \text{ V}$	$I_G = 160 \text{ mA}$		40		mA
$V_{TM}$	$T_j = 25 \text{ }^\circ\text{C}$	$I_{TM} = 80 \text{ A}$	$t_p = 10 \text{ ms}$			2	V
$I_{DRM}$	$V_{DRM}$ Specified			$T_j = 25 \text{ }^\circ\text{C}$		0.02	mA
				$T_j = 110 \text{ }^\circ\text{C}$		6	
$I_{RRM}$	$V_{RRM}$ Specified			$T_j = 25 \text{ }^\circ\text{C}$		0.02	mA
				$T_j = 110 \text{ }^\circ\text{C}$		6	
$t_{gt}$	$T_j = 25 \text{ }^\circ\text{C}$ $I_G = 200 \text{ mA}$	$V_D = V_{DRM}$ $di_G/dt = 0.2 \text{ A}/\mu\text{s}$	$I_T = 80 \text{ A}$		2		$\mu\text{s}$
$t_q$	$T_j = 110 \text{ }^\circ\text{C}$ $V_D = 67 \% V_{DRM}$ Gate Open	$I_T = 80 \text{ A}$ $di/dt = 30 \text{ A}/\mu\text{s}$	$V_R = 75 \text{ V}$ $dv/dt = 20 \text{ V}/\mu\text{s}$		100		$\mu\text{s}$
$dv/dt^*$	$T_j = 110 \text{ }^\circ\text{C}$ Linear Slope up to $V_D = 67 \% V_{DRM}$	Gate Open		$V_{DRM} \leq 800 \text{ V}$	500		V/ $\mu\text{s}$
				$V_{DRM} \geq 1000 \text{ V}$	250		

\* For higher guaranteed values, please consult us.

**PACKAGE MECHANICAL DATA : RD 91 Plastic**

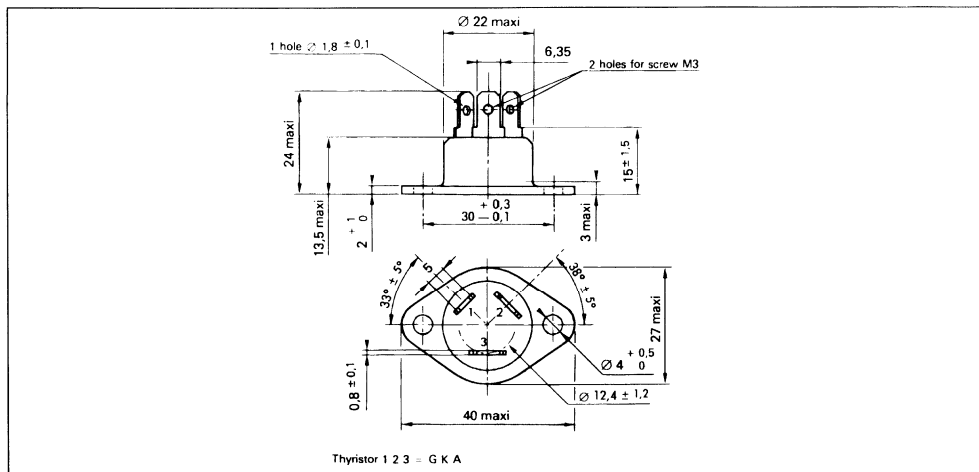

Cooling method : by conduction (method C)  
 Marking : type number  
 Weight : 15 g.



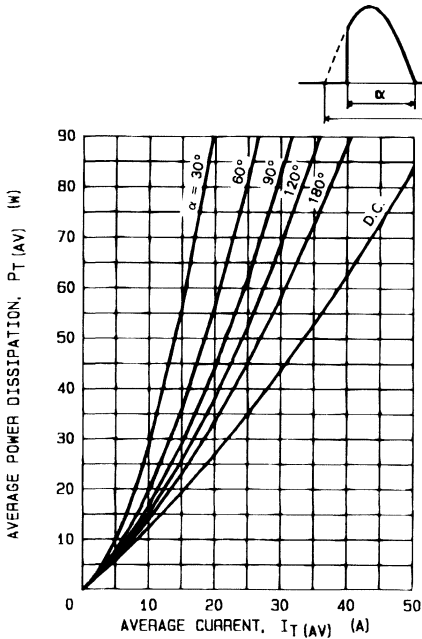

FIG.1 - MAXIMUM ON-STATE POWER DISSIPATION FOR SINUSOIDAL CURRENT WAVEFORM

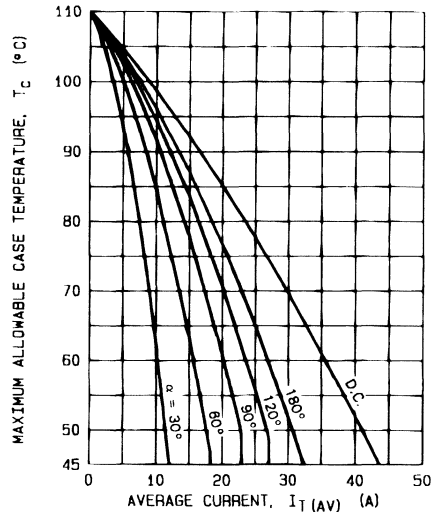

FIG.2 - MAXIMUM ALLOWABLE CASE TEMPERATURE FOR SINUSOIDAL CURRENT WAVEFORM

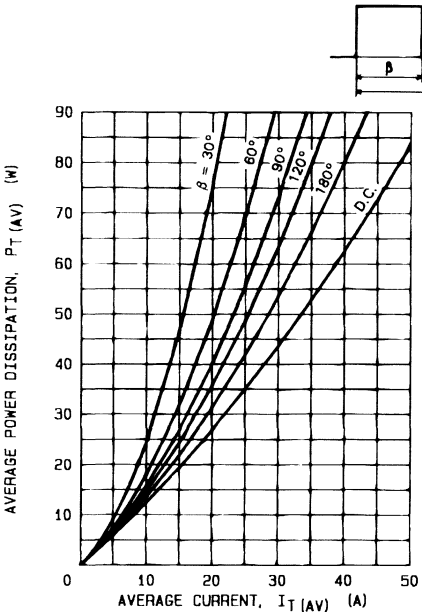

FIG.3 - MAXIMUM ON-STATE POWER DISSIPATION FOR RECTANGULAR CURRENT WAVEFORM

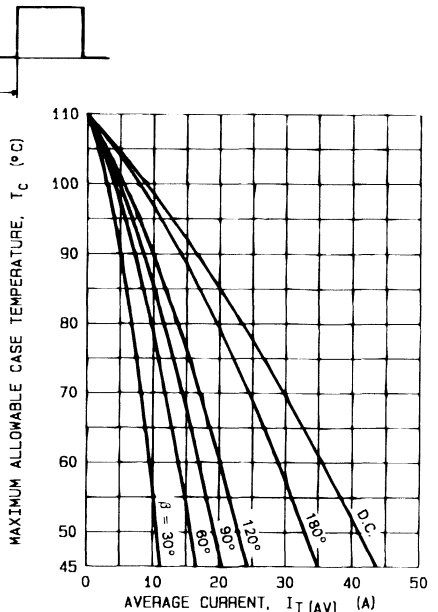

FIG.4 - MAXIMUM ALLOWABLE CASE TEMPERATURE FOR RECTANGULAR CURRENT WAVEFORM

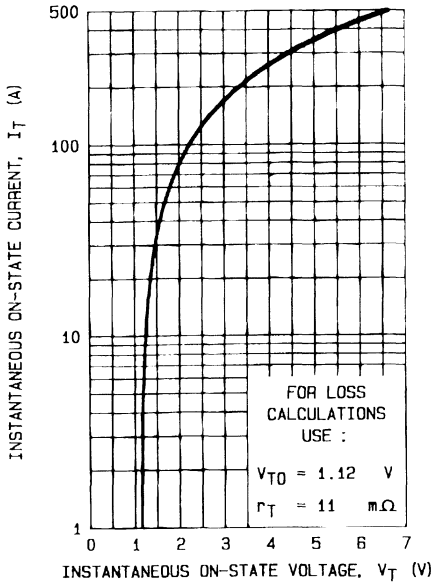

FIG.5 - MAXIMUM ON-STATE CONDUCTION CHARACTERISTIC ( $T_J = 110^\circ\text{C}$ ).

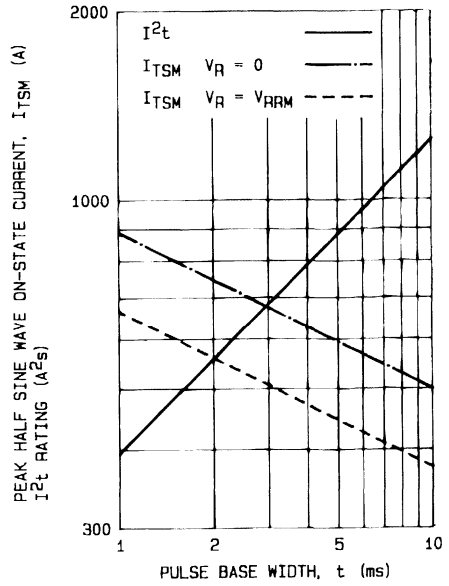

FIG.8 - NON REPETITIVE SUB-CYCLE SURGE ON-STATE CURRENT AND  $I^2t$  RATING (INITIAL  $T_J = 25^\circ\text{C}$ ).

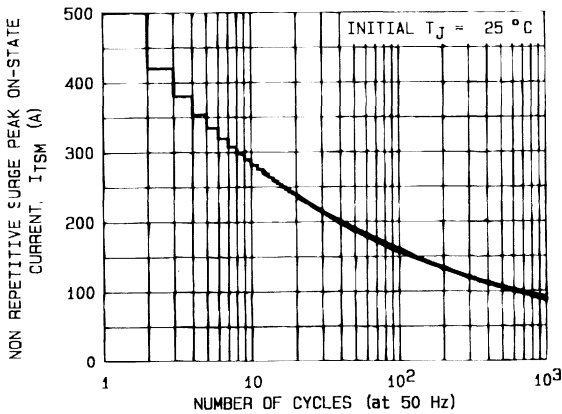

FIG.7 - NON REPETITIVE SURGE PEAK ON-STATE CURRENT VERSUS NUMBER OF CYCLES.

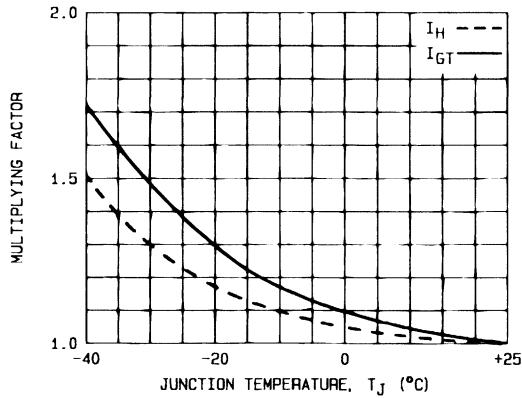

FIG. 8 - RELATIVE VARIATION OF GATE TRIGGER CURRENT AND HOLDING CURRENT VERSUS JUNCTION TEMPERATURE.

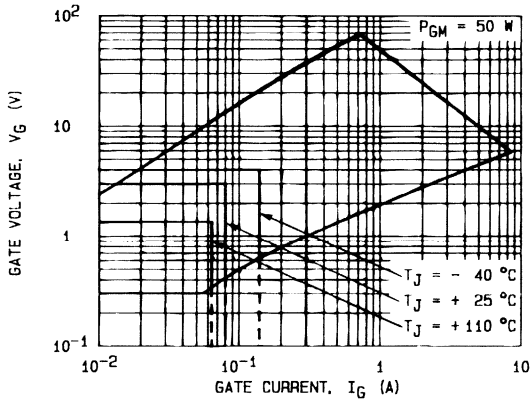
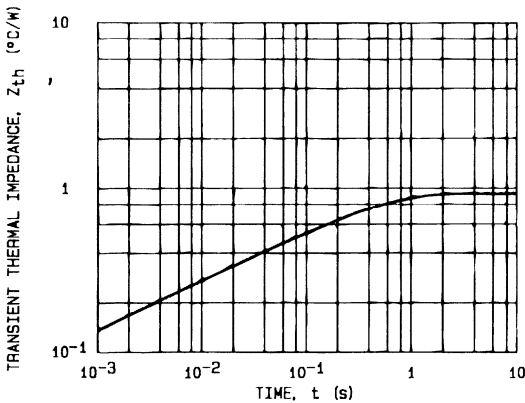

FIG. 9 - GATE TRIGGER CHARACTERISTICS.



Conduction angle ( $\alpha, \beta$ )	Effective thermal resistance ( $^{\circ}\text{C}/\text{W}$ ) junction to case	
	Sinusoidal	Rectangular
180°	1.00	0.99
120°	1.04	1.40
90°	1.12	1.58
60°	1.30	1.77
30°	1.67	2.23

FIG. 10 - TRANSIENT THERMAL IMPEDANCE JUNCTION TO CASE.



**THYRISTORS**

- GLASS PASSIVATED CHIP
- HIGH STABILITY AND RELIABILITY
- HIGH SURGE CAPABILITY
- EASY MOUNTING ON HEATSINK
- ISOLATED PACKAGE :  
INSULATING VOLTAGE 2500 V<sub>RMS</sub>
- UL RECOGNIZED (E81734)

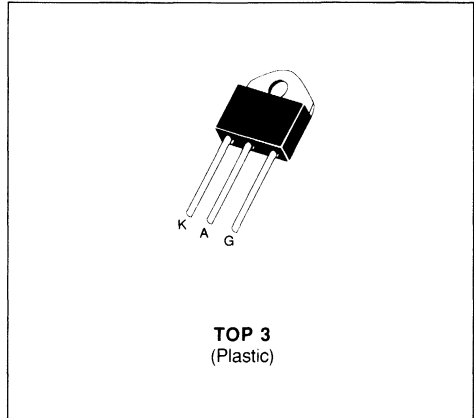
**DESCRIPTION**

General purpose SCR suited for power supplies up to 400 Hz on resistive or inductive loads.

**ABSOLUTE RATINGS** (limiting values)

Symbol	Parameter		BTW68-200 → 800	BTW68-1000/1200	Unit
$I_{T(RMS)}$	RMS on-state Current (1)	$T_c = 75\text{ }^\circ\text{C}$	30		A
$I_{T(AV)}$	Mean on-state Current (1)	$T_c = 75\text{ }^\circ\text{C}$	19		A
$I_{TSM}$	Non Repetitive Surge Peak on-state Current ( $T_j$ initial = $25\text{ }^\circ\text{C}$ ) (2)	$t = 8.3\text{ ms}$	420	315	A
		$t = 10\text{ ms}$	400	300	
$I^2t$	$I^2t$ Value for Fusing	$t = 10\text{ ms}$	800	450	A <sup>2</sup> s
di/dt	Critical Rate of Rise of on-state Current (3)		100		A/ $\mu$ s
$T_{stg}$ $T_j$	Storage and Operating Junction Temperature Range		- 40 to 125		$^\circ\text{C}$
			- 40 to 125		$^\circ\text{C}$

Symbol	Parameter	BTW68-						Unit
		200	400	600	800	1000	1200	
$V_{DRM}$ $V_{RRM}$	Repetitive Peak off-state Voltage (4)	200	400	600	800	1000	1200	V

(1) Single phase circuit,  $180^\circ$  conduction angle.

(2) Half sine wave.

(3)  $I_G = 500\text{ mA}$   $di_G/dt = 1\text{ A}/\mu\text{s}$ .

(4)  $T_j = 125\text{ }^\circ\text{C}$ .

**THERMAL RESISTANCES**

Symbol	Parameter	Value	Unit
$R_{th(j-c)}$	Junction-case for D.C.	1.25	$^\circ\text{C}/\text{W}$
$R_{th(c-h)}$	Contact (case to heatsink)	0.20	$^\circ\text{C}/\text{W}$

**GATE CHARACTERISTICS** (maximum values)

$P_{GM} = 50 \text{ W}$  ( $t_p = 10 \mu\text{s}$ )       $I_{FGM} = 2 \text{ A}$  ( $t_p = 10 \mu\text{s}$ )       $V_{RGM} = 5 \text{ V}$   
 $P_{G(AV)} = 1 \text{ W}$        $V_{FGM} = 15 \text{ V}$  ( $t_p = 10 \mu\text{s}$ )

**ELECTRICAL CHARACTERISTICS**

Symbol	Test Conditions			Min.	Typ.	Max.	Unit
$I_{GT}$	$T_j = 25 \text{ }^\circ\text{C}$ Pulse Duration > 20 $\mu\text{s}$	$V_D = 12 \text{ V}$	$R_L = 33 \text{ } \Omega$			50	mA
$V_{GT}$	$T_j = 25 \text{ }^\circ\text{C}$ Pulse Duration > 20 $\mu\text{s}$	$V_D = 12 \text{ V}$	$R_L = 33 \text{ } \Omega$			1.5	V
$V_{GD}$	$T_j = 125 \text{ }^\circ\text{C}$	$V_D = V_{DRM}$	$R_L = 3.3 \text{ k}\Omega$	0.2			V
$I_H$	$T_j = 25 \text{ }^\circ\text{C}$	$I_T = 0.5 \text{ A}$	Gate Open		20	75	mA
$I_L$	$T_j = 25 \text{ }^\circ\text{C}$ Pulse Duration > 20 $\mu\text{s}$	$V_D = 12 \text{ V}$	$I_G = 100 \text{ mA}$		40		mA
$V_{TM}$	$T_j = 25 \text{ }^\circ\text{C}$	$I_{TM} = 60 \text{ A}$	$t_p = 10 \text{ ms}$			2.1	V
$I_{DRM}$	$V_{DRM}$ Specified					$T_j = 25 \text{ }^\circ\text{C}$	mA
						$T_j = 125 \text{ }^\circ\text{C}$	
$I_{RRM}$	$V_{RRM}$ Specified					$T_j = 25 \text{ }^\circ\text{C}$	mA
						$T_j = 125 \text{ }^\circ\text{C}$	
$t_{gt}$	$T_j = 25 \text{ }^\circ\text{C}$ $I_G = 200 \text{ mA}$	$V_D = V_{DRM}$ $di_G/dt = 0.2 \text{ A}/\mu\text{s}$	$I_T = 60 \text{ A}$		2		$\mu\text{s}$
$t_q$	$T_j = 125 \text{ }^\circ\text{C}$ $V_D = 67 \% V_{DRM}$ Gate Open	$I_T = 60 \text{ A}$ $di/dt = 30 \text{ A}/\mu\text{s}$	$V_R = 75 \text{ V}$ $dv/dt = 20 \text{ V}/\mu\text{s}$		100		$\mu\text{s}$
$dv/dt^*$	$T_j = 125 \text{ }^\circ\text{C}$ Linear Slope up to $V_D = 67 \% V_{DRM}$	Gate Open		$V_{DRM} \leq 800 \text{ V}$	500		V/ $\mu\text{s}$
				$V_{DRM} \geq 1000 \text{ V}$	250		

\* For higher guaranteed values, please consult us.

**PACKAGE MECHANICAL DATA : TOP 3 Plastic**

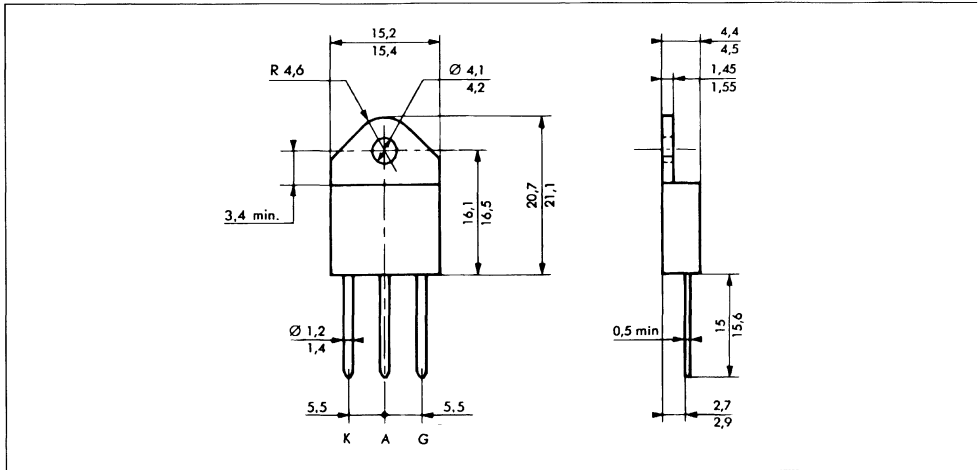

Cooling method : by conduction (method C)  
 Marking : type number  
 Weight : 5 g.

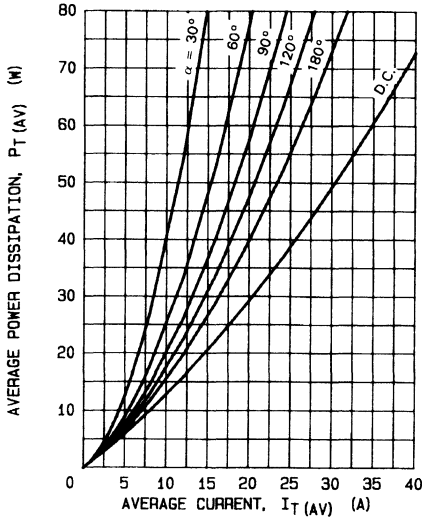
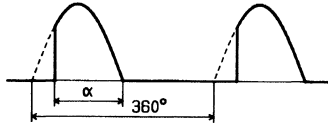

FIG.1 - MAXIMUM ON-STATE POWER DISSIPATION FOR SINUSOIDAL CURRENT WAVEFORM

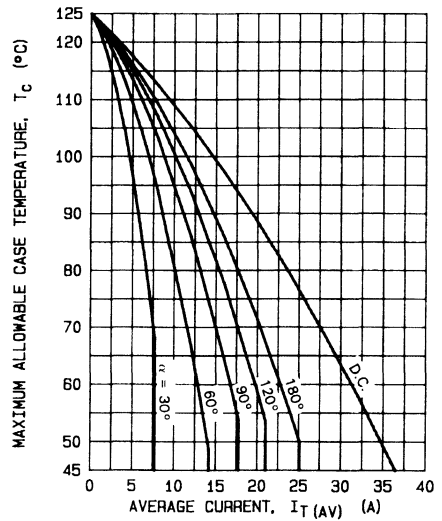

FIG.2 - MAXIMUM ALLOWABLE CASE TEMPERATURE FOR SINUSOIDAL CURRENT WAVEFORM

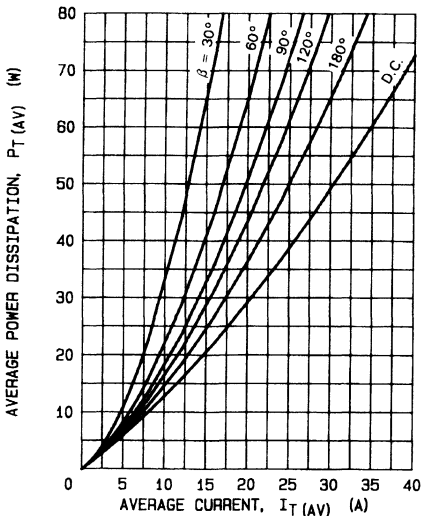
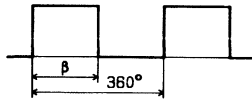

FIG.3 - MAXIMUM ON-STATE POWER DISSIPATION FOR RECTANGULAR CURRENT WAVEFORM

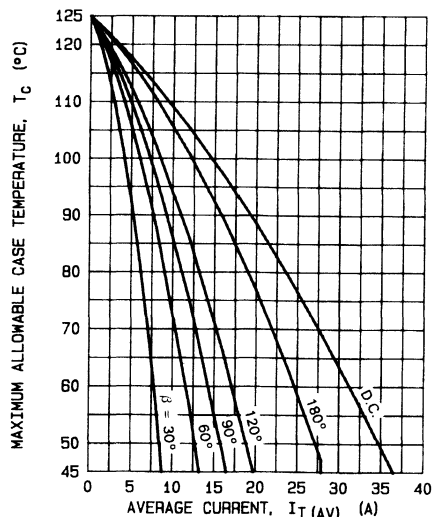

FIG.4 - MAXIMUM ALLOWABLE CASE TEMPERATURE FOR RECTANGULAR CURRENT WAVEFORM

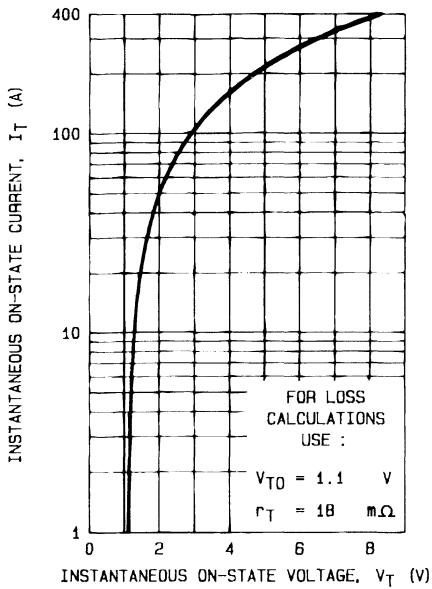

FIG.5 - MAXIMUM ON-STATE CONDUCTION CHARACTERISTIC ( $T_J = 125^\circ\text{C}$ ).

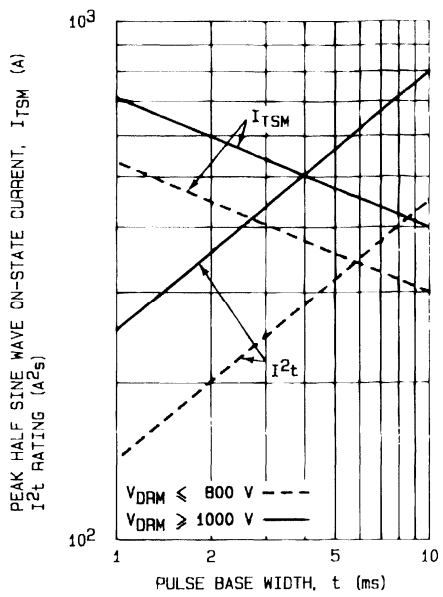

FIG.6 - NON REPETITIVE SUB-CYCLE SURGE ON-STATE CURRENT AND  $I^2t$  RATING (INITIAL  $T_J = 25^\circ\text{C}$ ).

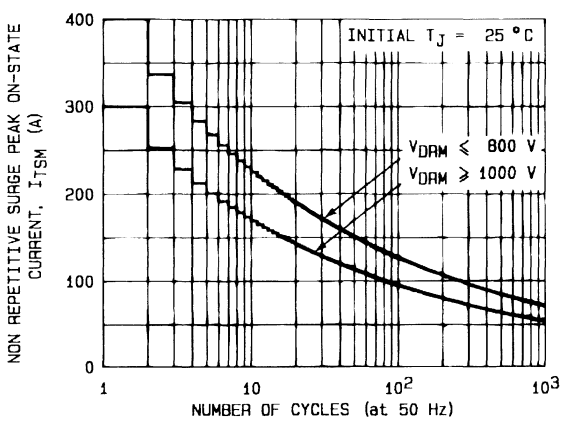

FIG.7 - NON REPETITIVE SURGE PEAK ON-STATE CURRENT VERSUS NUMBER OF CYCLES.



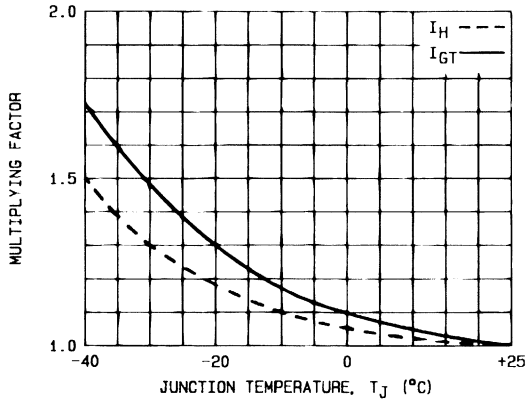

FIG.8 - RELATIVE VARIATION OF GATE TRIGGER CURRENT AND HOLDING CURRENT VERSUS JUNCTION TEMPERATURE.

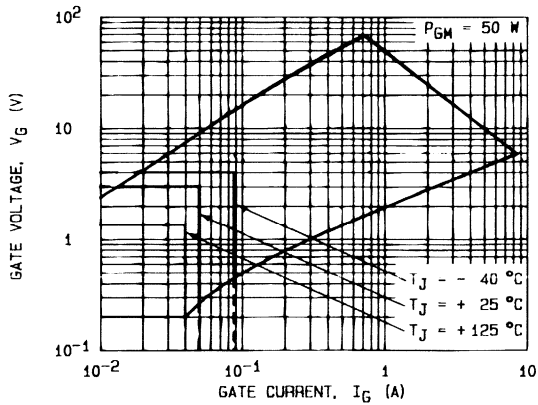
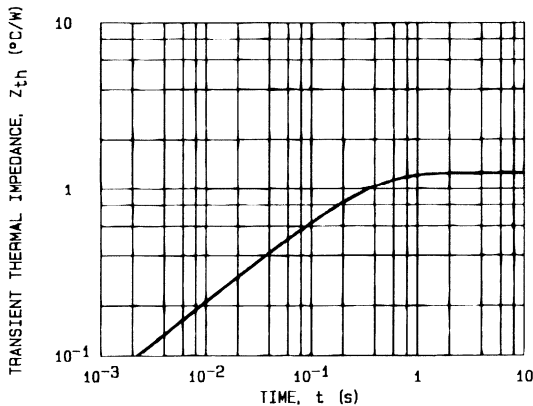

FIG.9 - GATE TRIGGER CHARACTERISTICS.



Conduction angle ( $\alpha, \beta$ )	Effective thermal resistance ( $^{\circ}\text{C}/\text{W}$ ) junction to case	
	Sinusoidal	Rectangular
180°	1.35	1.33
120°	1.40	1.88
90°	1.50	2.13
60°	1.75	2.38
30°	2.25	3.00

FIG.10 - TRANSIENT THERMAL IMPEDANCE JUNCTION TO CASE.





**THYRISTORS**

- GLASS PASSIVATED CHIP
- HIGH STABILITY AND RELIABILITY
- HIGH SURGE CAPABILITY
- EASY MOUNTING ON HEATSINK

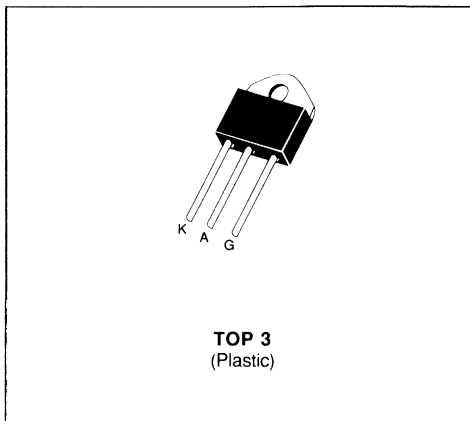

**DESCRIPTION**

General purpose SCR suited for power supplies up to 400 Hz on resistive or inductive loads.

**ABSOLUTE RATINGS** (limiting values)

Symbol	Parameter		BTW68-200N → 800N		BTW68-1000N/1200N		Unit
$I_{T(RMS)}$	RMS on-state Current (1)	$T_c = 75\text{ }^\circ\text{C}$	35				A
$I_{T(AV)}$	Mean on-state Current (1)	$T_c = 75\text{ }^\circ\text{C}$	22				A
$I_{TSM}$	Non Repetitive Surge Peak on-state Current ( $T_j$ initial = $25\text{ }^\circ\text{C}$ ) (2)	$t = 8.3\text{ ms}$	420	315		A	
		$t = 10\text{ ms}$	400	300			
$I^2t$	$I^2t$ Value for Fusing	$t = 10\text{ ms}$	800	450		$\text{A}^2\text{s}$	
$di/dt$	Critical Rate of Rise of on-state Current (3)		100				$\text{A}/\mu\text{s}$
$T_{stg}$ $T_j$	Storage and Operating Junction Temperature Range		- 40 to 125				$^\circ\text{C}$
			- 40 to 125				$^\circ\text{C}$

Symbol	Parameter	BTW68-						Unit
		200N	400N	600N	800N	1000N	1200N	
$V_{DRM}$ $V_{RRM}$	Repetitive Peak off-state Voltage (4)	200	400	600	800	1000	1200	V

(1) Single phase circuit,  $180^\circ$  conduction angle.

(2) Half sine wave.

(3)  $I_G = 500\text{ mA}$   $di_G/dt = 1\text{ A}/\mu\text{s}$ .

(4)  $T_j = 125\text{ }^\circ\text{C}$ .

**THERMAL RESISTANCES**

Symbol	Parameter	Value	Unit
$R_{th(j-c)}$	Junction-case for D.C.	1.1	$^\circ\text{C}/\text{W}$
$R_{th(c-h)}$	Contact (case to heatsink)	0.20	$^\circ\text{C}/\text{W}$

**GATE CHARACTERISTICS** (maximum values)

$P_{GM} = 50 \text{ W}$  ( $t_p = 10 \mu\text{s}$ )       $I_{FGM} = 2 \text{ A}$  ( $t_p = 10 \mu\text{s}$ )       $V_{RGM} = 5 \text{ V}$   
 $P_{G(AV)} = 1 \text{ W}$        $V_{FGM} = 15 \text{ V}$  ( $t_p = 10 \mu\text{s}$ )

**ELECTRICAL CHARACTERISTICS**

Symbol	Test Conditions			Min.	Typ.	Max.	Unit
$I_{GT}$	$T_j = 25 \text{ }^\circ\text{C}$ Pulse Duration > 20 $\mu\text{s}$	$V_D = 12 \text{ V}$	$R_L = 33 \text{ } \Omega$			50	mA
$V_{GT}$	$T_j = 25 \text{ }^\circ\text{C}$ Pulse Duration > 20 $\mu\text{s}$	$V_D = 12 \text{ V}$	$R_L = 33 \text{ } \Omega$			1.5	V
$V_{GD}$	$T_j = 125 \text{ }^\circ\text{C}$	$V_D = V_{DRM}$	$R_L = 3.3 \text{ k}\Omega$	0.2			V
$I_H$	$T_j = 25 \text{ }^\circ\text{C}$	$I_T = 0.5 \text{ A}$	Gate Open		20	75	mA
$I_L$	$T_j = 25 \text{ }^\circ\text{C}$ Pulse Duration > 20 $\mu\text{s}$	$V_D = 12 \text{ V}$	$I_G = 100 \text{ mA}$		40		mA
$V_{TM}$	$T_j = 25 \text{ }^\circ\text{C}$	$I_{TM} = 70 \text{ A}$	$t_p = 10 \text{ ms}$			2.25	V
$I_{DRM}$	$V_{DRM}$ Specified			$T_j = 25 \text{ }^\circ\text{C}$		0.02	mA
				$T_j = 125 \text{ }^\circ\text{C}$		3	
$I_{RRM}$	$V_{RRM}$ Specified			$T_j = 25 \text{ }^\circ\text{C}$		0.02	mA
				$T_j = 125 \text{ }^\circ\text{C}$		3	
$t_{gt}$	$T_j = 25 \text{ }^\circ\text{C}$ $I_G = 200 \text{ mA}$	$V_D = V_{DRM}$ $di_G/dt = 0.2 \text{ A}/\mu\text{s}$	$I_T = 70 \text{ A}$		2		$\mu\text{s}$
$t_q$	$T_j = 125 \text{ }^\circ\text{C}$ $V_D = 67 \% V_{DRM}$ Gate Open	$I_T = 70 \text{ A}$ $di/dt = 30 \text{ A}/\mu\text{s}$	$V_R = 75 \text{ V}$ $dv/dt = 20 \text{ V}/\mu\text{s}$		100		$\mu\text{s}$
$dv/dt^*$	$T_j = 125 \text{ }^\circ\text{C}$ Linear Slope up to $V_D = 67 \% V_{DRM}$	Gate Open		$V_{DRM} \leq 800 \text{ V}$	500		V/ $\mu\text{s}$
				$V_{DRM} \geq 1000 \text{ V}$	250		

\* For higher guaranteed values, please consult us.

**PACKAGE MECHANICAL DATA : TOP 3 Plastic**

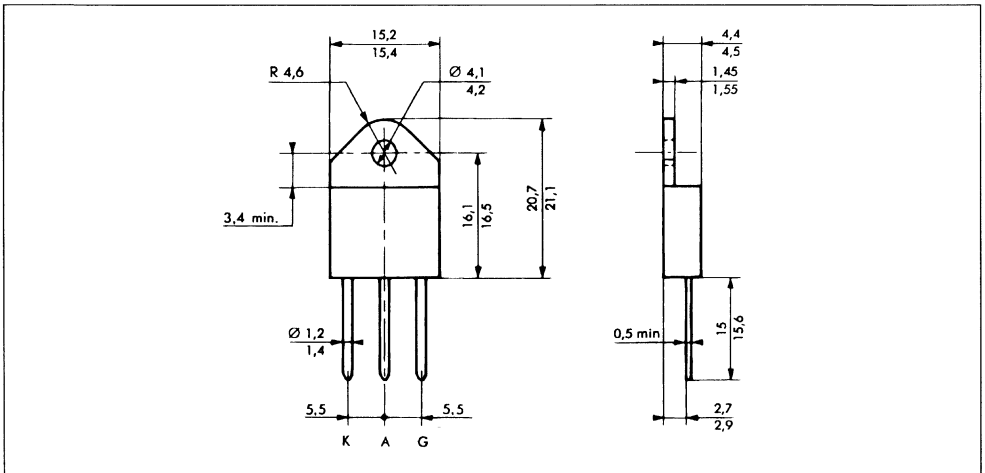

Cooling method : by conduction (method C)  
 Marking : type number  
 Weight : 5 g.

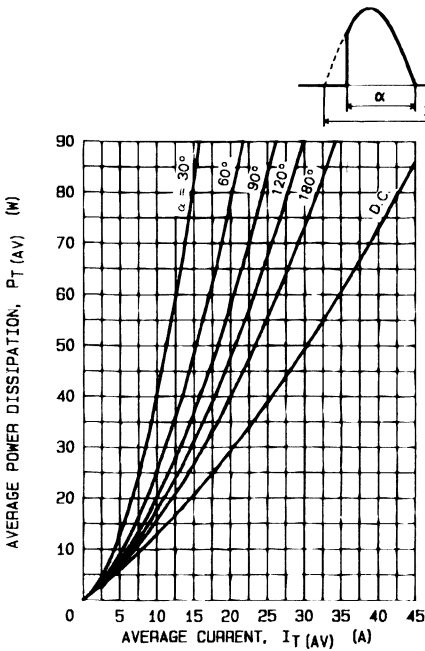

FIG.1 - MAXIMUM ON-STATE POWER DISSIPATION FOR SINUSOIDAL CURRENT WAVEFORM

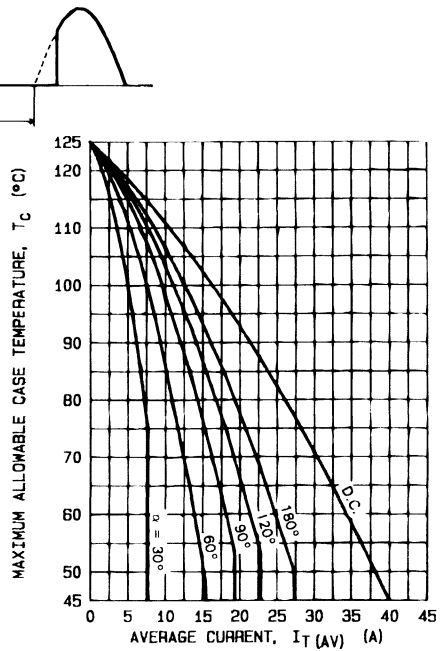

FIG.2 - MAXIMUM ALLOWABLE CASE TEMPERATURE FOR SINUSOIDAL CURRENT WAVEFORM

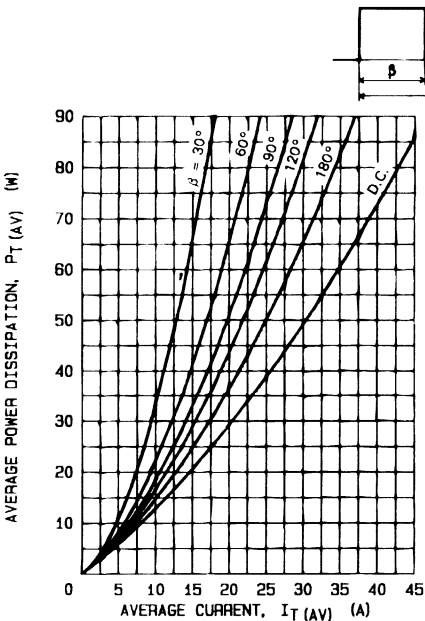

FIG.3 - MAXIMUM ON-STATE POWER DISSIPATION FOR RECTANGULAR CURRENT WAVEFORM

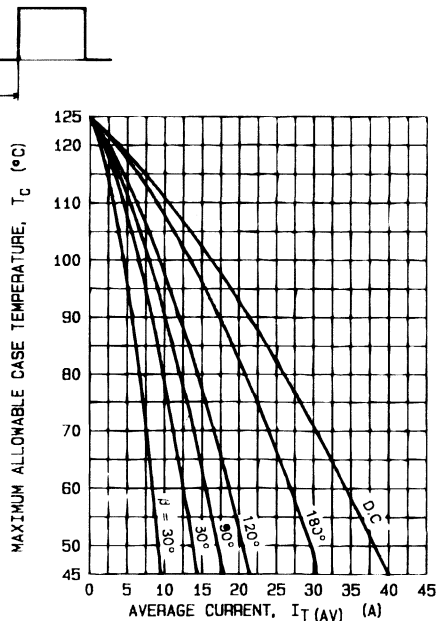

FIG.4 - MAXIMUM ALLOWABLE CASE TEMPERATURE FOR RECTANGULAR CURRENT WAVEFORM

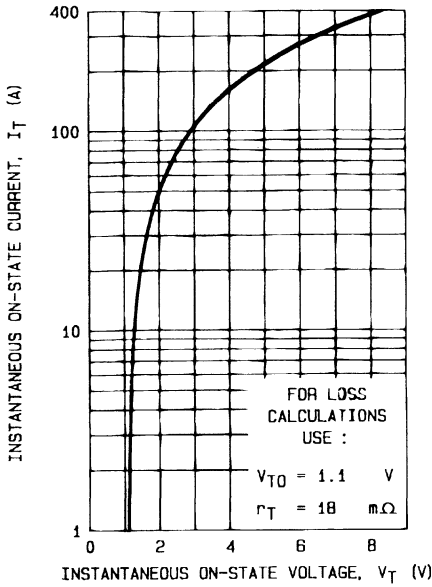

FIG.5 - MAXIMUM ON-STATE CONDUCTION CHARACTERISTIC ( $T_J = 125^\circ\text{C}$ ).

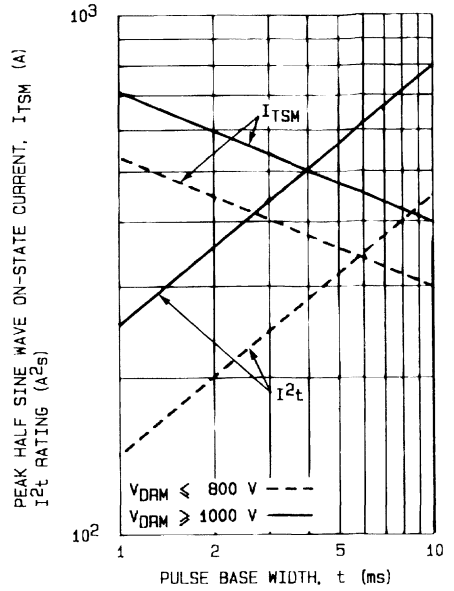

FIG.6 - NON REPETITIVE SUB-CYCLE SURGE ON-STATE CURRENT AND  $I^2t$  RATING (INITIAL  $T_J = 25^\circ\text{C}$ ).

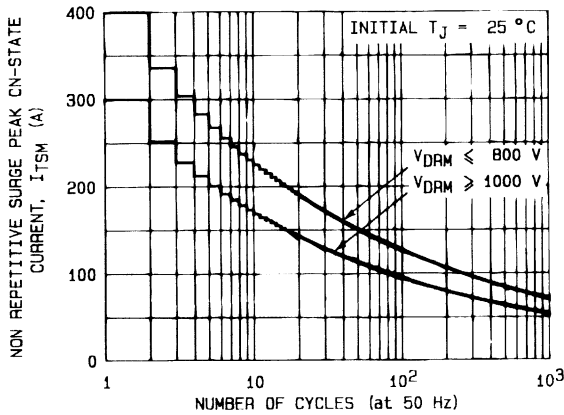

FIG.7 - NON REPETITIVE SURGE PEAK ON-STATE CURRENT VERSUS NUMBER OF CYCLES.

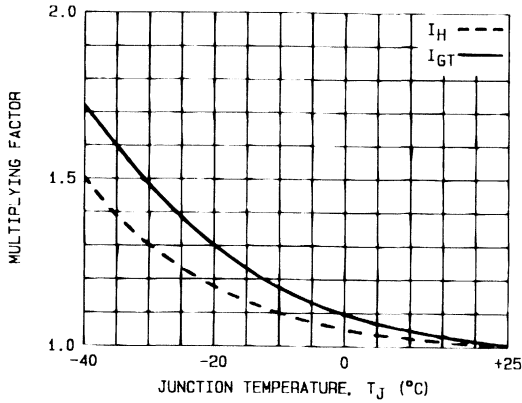

FIG.8 - RELATIVE VARIATION OF GATE TRIGGER CURRENT AND HOLDING CURRENT VERSUS JUNCTION TEMPERATURE.

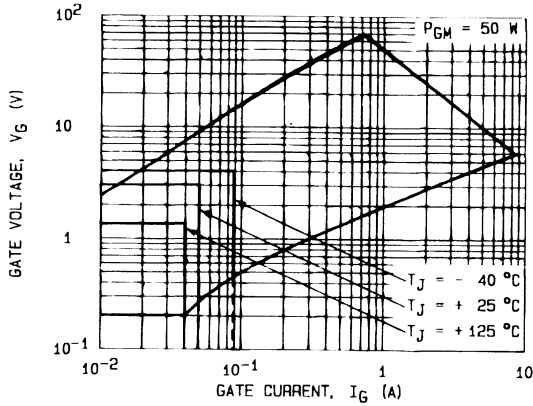
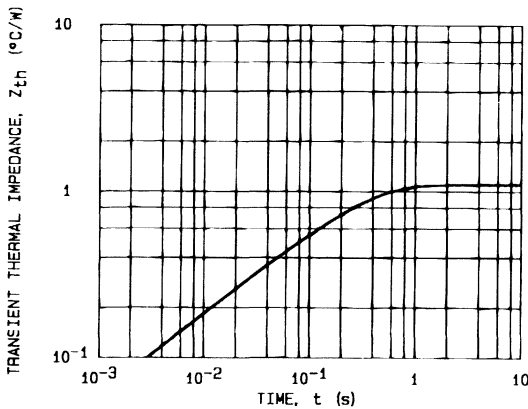

FIG.9 - GATE TRIGGER CHARACTERISTICS.



Conduction angle (α,β)	Effective thermal resistance (°C/W) junction to case	
	Sinusoidal	Rectangular
180°	1.19	1.17
120°	1.23	1.65
90°	1.32	1.87
60°	1.54	2.09
30°	1.98	2.64

FIG.10 - TRANSIENT THERMAL IMPEDANCE JUNCTION TO CASE.





**THYRISTORS**

- GLASS PASSIVATED CHIP
- HIGH STABILITY AND RELIABILITY
- HIGH SURGE CAPABILITY
- HIGH ON-STATE CURRENT
- EASY MOUNTING ON HEATSINK
- ISOLATED PACKAGE :  
INSULATING VOLTAGE 2500 V<sub>RMS</sub>
- UL RECOGNIZED (E81734)

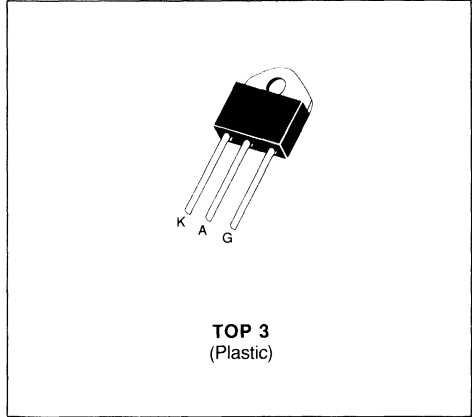
**DESCRIPTION**

General purpose SCR suited for power supplies up to 400 Hz on resistive or inductive loads.

**ABSOLUTE RATINGS** (limiting values)

Symbol	Parameter		BTW69-200 → 800		BTW69-1000/1200		Unit
$I_{T(RMS)}$	RMS on-state Current (1)	$T_c = 70\text{ }^\circ\text{C}$	50				A
$I_{T(AV)}$	Mean on-state Current (1)	$T_c = 70\text{ }^\circ\text{C}$	32				A
$I_{TSM}$	Non Repetitive Surge Peak on-state Current ( $T_j$ initial = $25\text{ }^\circ\text{C}$ ) (2)	$t = 8.3\text{ ms}$	525	420			A
		$t = 10\text{ ms}$	500	400			
$I^2t$	$I^2t$ Value for Fusing	$t = 10\text{ ms}$	1250	800			A <sup>2</sup> s
$di/dt$	Critical Rate of Rise of on-state Current (3)		100				A/ $\mu$ s
$T_{stg}$ $T_j$	Storage and Operating Junction Temperature Range		- 40 to 125				$^\circ\text{C}$
			- 40 to 125				$^\circ\text{C}$

Symbol	Parameter	BTW69-						Unit
		200	400	600	800	1000	1200	
$V_{DRM}$ $V_{RRM}$	Repetitive Peak off-state Voltage (4)	200	400	600	800	1000	1200	V

(1) Single phase circuit,  $180^\circ$  conduction angle.

(2) Half sine wave.

(3)  $I_G = 800\text{ mA}$   $di_G/dt = 1\text{ A}/\mu\text{s}$ .

(4)  $T_j = 125\text{ }^\circ\text{C}$ .

**THERMAL RESISTANCES**

Symbol	Parameter	Value	Unit
$R_{th(j-c)}$	Junction-case for D.C.	1	$^\circ\text{C}/\text{W}$
$R_{th(c-h)}$	Contact (case to heatsink)	0.20	$^\circ\text{C}/\text{W}$

**GATE CHARACTERISTICS** (maximum values)

$P_{GM} = 50 \text{ W}$  ( $t_p = 10 \mu\text{s}$ )       $I_{FGM} = 2 \text{ A}$  ( $t_p = 10 \mu\text{s}$ )       $V_{RGM} = 5 \text{ V}$   
 $P_{G(AV)} = 1 \text{ W}$        $V_{FGM} = 15 \text{ V}$  ( $t_p = 10 \mu\text{s}$ )

**ELECTRICAL CHARACTERISTICS**

Symbol	Test Conditions			Min.	Typ.	Max.	Unit
$I_{GT}$	$T_j = 25 \text{ }^\circ\text{C}$ Pulse Duration > 20 $\mu\text{s}$	$V_D = 12 \text{ V}$	$R_L = 33 \text{ } \Omega$			80	mA
$V_{GT}$	$T_j = 25 \text{ }^\circ\text{C}$ Pulse Duration > 20 $\mu\text{s}$	$V_D = 12 \text{ V}$	$R_L = 33 \text{ } \Omega$			1.5	V
$V_{GD}$	$T_j = 125 \text{ }^\circ\text{C}$	$V_D = V_{DRM}$	$R_L = 3.3 \text{ k}\Omega$	0.2			V
$I_H$	$T_j = 25 \text{ }^\circ\text{C}$	$I_T = 0.5 \text{ A}$	Gate Open		20	150	mA
$I_L$	$T_j = 25 \text{ }^\circ\text{C}$ Pulse Duration > 20 $\mu\text{s}$	$V_D = 12 \text{ V}$	$I_G = 160 \text{ mA}$		40		mA
$V_{TM}$	$T_j = 25 \text{ }^\circ\text{C}$	$I_{TM} = 100 \text{ A}$	$t_p = 10 \text{ ms}$			1.9	V
$I_{DRM}$	$V_{DRM}$ Specified			$T_j = 25 \text{ }^\circ\text{C}$		0.02	mA
				$T_j = 125 \text{ }^\circ\text{C}$		6	
$I_{RRM}$	$V_{RRM}$ Specified			$T_j = 25 \text{ }^\circ\text{C}$		0.02	mA
				$T_j = 125 \text{ }^\circ\text{C}$		6	
$t_{gt}$	$T_j = 25 \text{ }^\circ\text{C}$ $I_G = 200 \text{ mA}$	$V_D = V_{DRM}$ $di_G/dt = 0.2 \text{ A}/\mu\text{s}$	$I_T = 100 \text{ A}$		2		$\mu\text{s}$
$t_q$	$T_j = 125 \text{ }^\circ\text{C}$ $V_D = 67\% V_{DRM}$ Gate Open	$I_T = 100 \text{ A}$ $di/dt = 30 \text{ A}/\mu\text{s}$	$V_R = 75 \text{ V}$ $dv/dt = 20 \text{ V}/\mu\text{s}$		100		$\mu\text{s}$
$dv/dt^*$	$T_j = 125 \text{ }^\circ\text{C}$ Linear Slope up to $V_D = 67\% V_{DRM}$	Gate Open		$V_{DRM} \leq 800 \text{ V}$	500		$V/\mu\text{s}$
				$V_{DRM} \geq 1000 \text{ V}$	250		

\* For higher guaranteed values, please consult us.

**PACKAGE MECHANICAL DATA : TOP 3 Plastic**

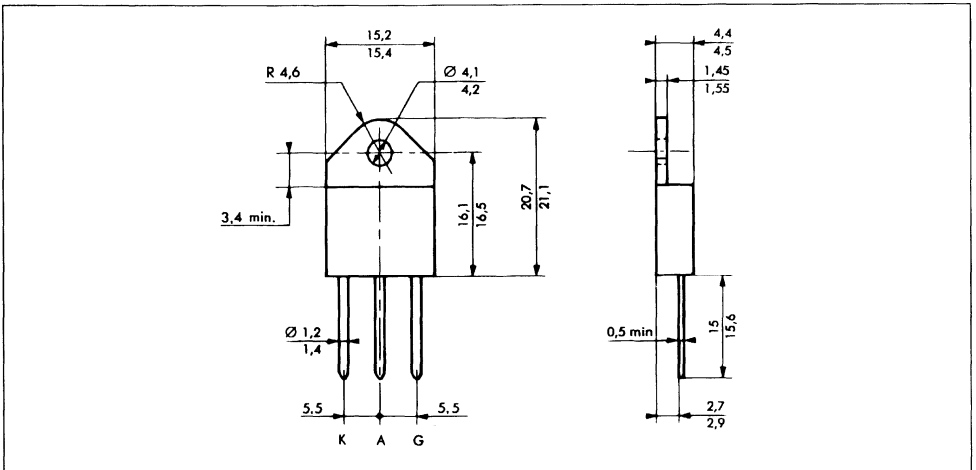

Cooling method : by conduction (method C)  
 Marking : type number  
 Weight : 5 g.

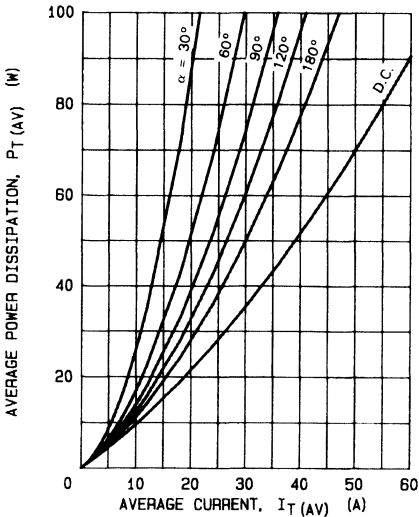
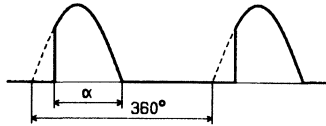

FIG.1 - MAXIMUM ON-STATE POWER DISSIPATION FOR SINUSOIDAL CURRENT WAVEFORM

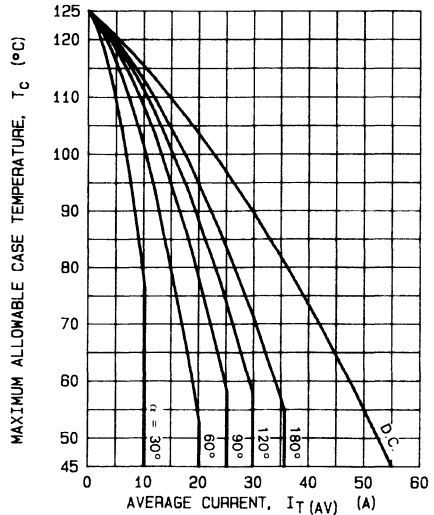

FIG.2 - MAXIMUM ALLOWABLE CASE TEMPERATURE FOR SINUSOIDAL CURRENT WAVEFORM

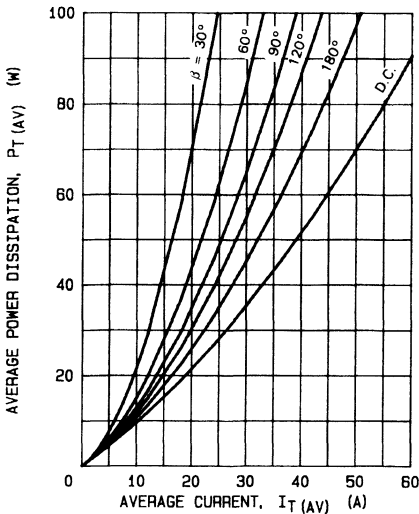
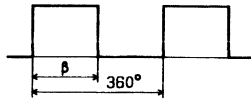

FIG.3 - MAXIMUM ON-STATE POWER DISSIPATION FOR RECTANGULAR CURRENT WAVEFORM

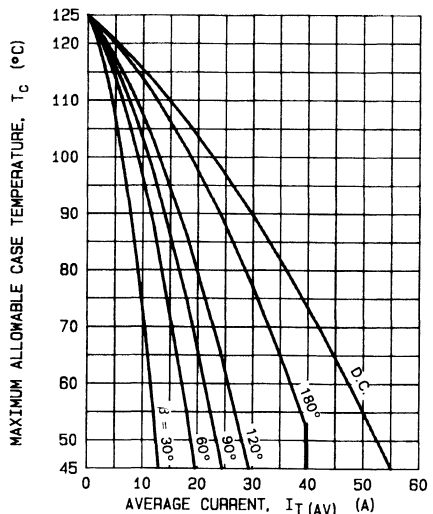

FIG.4 - MAXIMUM ALLOWABLE CASE TEMPERATURE FOR RECTANGULAR CURRENT WAVEFORM

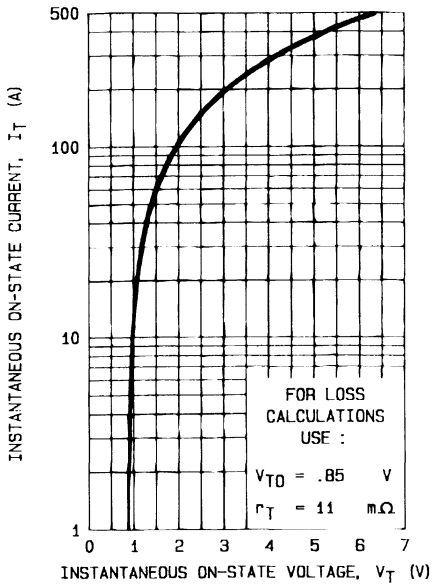

FIG.5 - MAXIMUM ON-STATE CONDUCTION CHARACTERISTIC ( $T_J = 125^\circ\text{C}$ ).

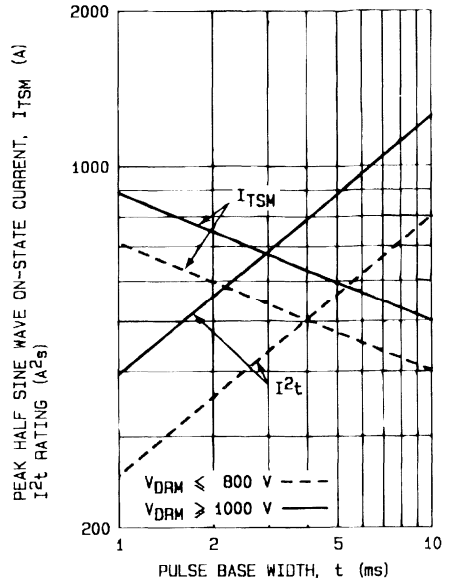

FIG.8 - NON REPETITIVE SUB-CYCLE SURGE ON-STATE CURRENT AND  $I^2t$  RATING (INITIAL  $T_J = 25^\circ\text{C}$ ).

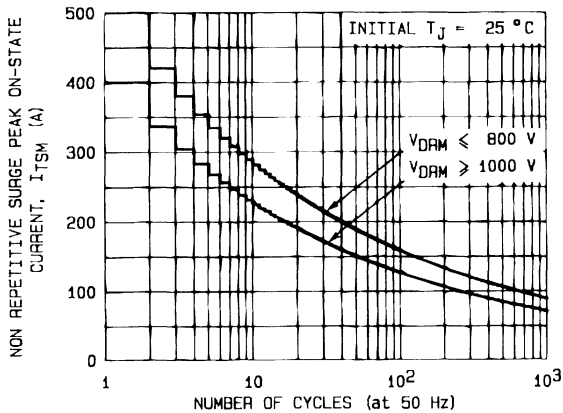

FIG.7 - NON REPETITIVE SURGE PEAK ON-STATE CURRENT VERSUS NUMBER OF CYCLES.

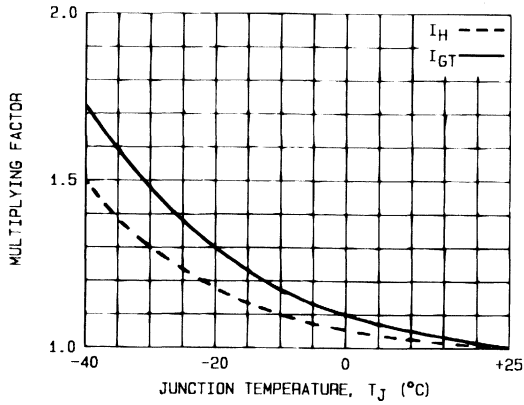

FIG.8 - RELATIVE VARIATION OF GATE TRIGGER CURRENT AND HOLDING CURRENT VERSUS JUNCTION TEMPERATURE.

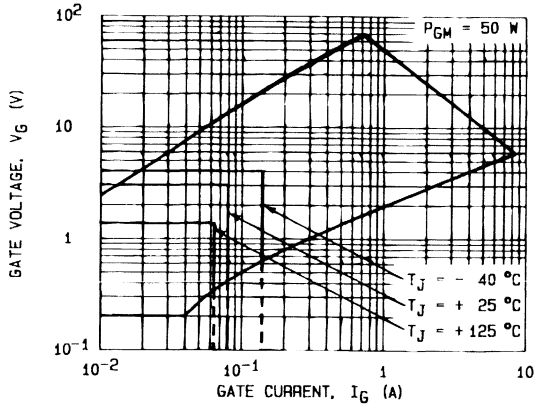
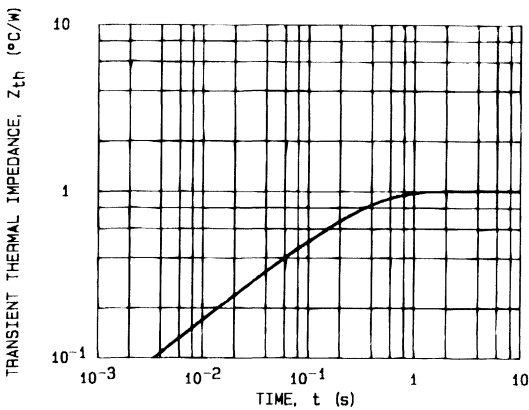

FIG.9 - GATE TRIGGER CHARACTERISTICS.



Conduction angle ( $\alpha, \beta$ )	Effective thermal resistance ( $^{\circ}\text{C}/\text{W}$ ) junction to case	
	Sinusoidal	Rectangular
180°	1.08	1.06
120°	1.12	1.50
90°	1.20	1.70
60°	1.40	1.90
30°	1.80	2.40

FIG.10 - TRANSIENT THERMAL IMPEDANCE JUNCTION TO CASE.





**THYRISTORS**

- GLASS PASSIVATED CHIP
- HIGH STABILITY AND RELIABILITY
- HIGH SURGE CAPABILITY
- HIGH ON-STATE CURRENT
- EASY MOUNTING ON HEATSINK

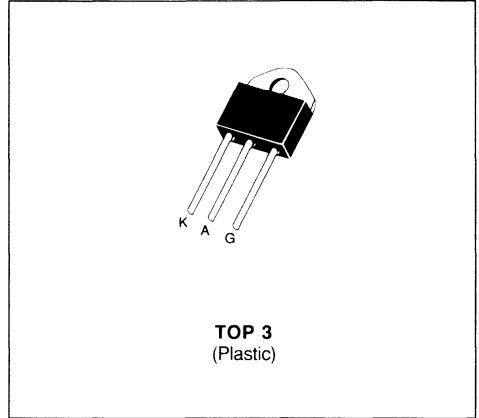

**DESCRIPTION**

General purpose SCR suited for power supplies up to 400 Hz on resistive or inductive loads.

**ABSOLUTE RATINGS** (limiting values)

Symbol	Parameter		BTW69-200N → 800N		BTW69-1000N/1200N		Unit
$I_{T(RMS)}$	RMS on-state Current (1)	$T_c = 70\text{ }^\circ\text{C}$	55				A
$I_{T(AV)}$	Mean on-state Current (1)	$T_c = 70\text{ }^\circ\text{C}$	35				A
$I_{TSM}$	Non Repetitive Surge Peak on-state Current ( $T_j$ initial = $25\text{ }^\circ\text{C}$ ) (2)	$t = 8.3\text{ ms}$	525	420		A	
		$t = 10\text{ ms}$	500	400			
$I^2t$	$I^2t$ Value for Fusing	$t = 10\text{ ms}$	1250	800		$\text{A}^2\text{s}$	
$di/dt$	Critical Rate of Rise of on-state Current (3)		100				$\text{A}/\mu\text{s}$
$T_{stg}$ $T_j$	Storage and Operating Junction Temperature Range		- 40 to 125				$^\circ\text{C}$
			- 40 to 125				$^\circ\text{C}$

Symbol	Parameter	BTW69-						Unit
		200N	400N	600N	800N	1000N	1200N	
$V_{DRM}$ $V_{RRM}$	Repetitive Peak off state Voltage (4)	200	400	600	800	1000	1200	V

(1) Single phase circuit,  $180^\circ$  conduction angle.

(2) Half sine wave.

(3)  $I_G = 800\text{ mA}$   $di_G/dt = 1\text{ A}/\mu\text{s}$ .

(4)  $T_j = 125\text{ }^\circ\text{C}$ .

**THERMAL RESISTANCES**

Symbol	Parameter	Value	Unit
$R_{th(j-c)}$	Junction-case for D.C.	0.87	$^\circ\text{C}/\text{W}$
$R_{th(c-h)}$	Contact (case to heatsink)	0.20	$^\circ\text{C}/\text{W}$

**GATE CHARACTERISTICS** (maximum values)

$P_{GM} = 50 \text{ W}$  ( $t_p = 10 \mu\text{s}$ )

$I_{FGM} = 2 \text{ A}$  ( $t_p = 10 \mu\text{s}$ )

$V_{RGM} = 5 \text{ V}$

$P_{G(AV)} = 1 \text{ W}$

$V_{FGM} = 15 \text{ V}$  ( $t_p = 10 \mu\text{s}$ )

**ELECTRICAL CHARACTERISTICS**

Symbol	Test Conditions			Min.	Typ.	Max.	Unit
$I_{GT}$	$T_j = 25 \text{ }^\circ\text{C}$ Pulse Duration > 20 $\mu\text{s}$	$V_D = 12 \text{ V}$	$R_L = 33 \text{ } \Omega$			80	mA
$V_{GT}$	$T_j = 25 \text{ }^\circ\text{C}$ Pulse Duration > 20 $\mu\text{s}$	$V_D = 12 \text{ V}$	$R_L = 33 \text{ } \Omega$			1.5	V
$V_{GD}$	$T_j = 125 \text{ }^\circ\text{C}$	$V_D = V_{DRM}$	$R_L = 3.3 \text{ k}\Omega$	0.2			V
$I_H$	$T_j = 25 \text{ }^\circ\text{C}$	$I_T = 0.5 \text{ A}$	Gate Open		20	150	mA
$I_L$	$T_j = 25 \text{ }^\circ\text{C}$ Pulse Duration > 20 $\mu\text{s}$	$V_D = 12 \text{ V}$	$I_G = 160 \text{ mA}$		40		mA
$V_{TM}$	$T_j = 25 \text{ }^\circ\text{C}$	$I_{TM} = 110 \text{ A}$	$t_p = 10 \text{ ms}$			2	V
$I_{DRM}$	$V_{DRM}$ Specified			$T_j = 25 \text{ }^\circ\text{C}$		0.02	mA
				$T_j = 125 \text{ }^\circ\text{C}$		6	
$I_{RRM}$	$V_{RRM}$ Specified			$T_j = 25 \text{ }^\circ\text{C}$		0.02	mA
				$T_j = 125 \text{ }^\circ\text{C}$		6	
$t_{gt}$	$T_j = 25 \text{ }^\circ\text{C}$ $I_G = 200 \text{ mA}$	$V_D = V_{DRM}$ $di/dt = 0.2 \text{ A}/\mu\text{s}$	$I_T = 110 \text{ A}$		2		$\mu\text{s}$
$t_q$	$T_j = 125 \text{ }^\circ\text{C}$ $V_D = 67 \% V_{DRM}$ Gate Open	$I_T = 110 \text{ A}$ $di/dt = 30 \text{ A}/\mu\text{s}$	$V_R = 75 \text{ V}$ $dv/dt = 20 \text{ V}/\mu\text{s}$		100		$\mu\text{s}$
$dv/dt^*$	$T_j = 125 \text{ }^\circ\text{C}$ Linear Slope up to $V_D = 67 \% V_{DRM}$	Gate Open		$V_{DRM} \leq 800 \text{ V}$	500		V/ $\mu\text{s}$
				$V_{DRM} \geq 1000 \text{ V}$	250		

\* For higher guaranteed values, please consult us.

**PACKAGE MECHANICAL DATA : TOP 3 Plastic**

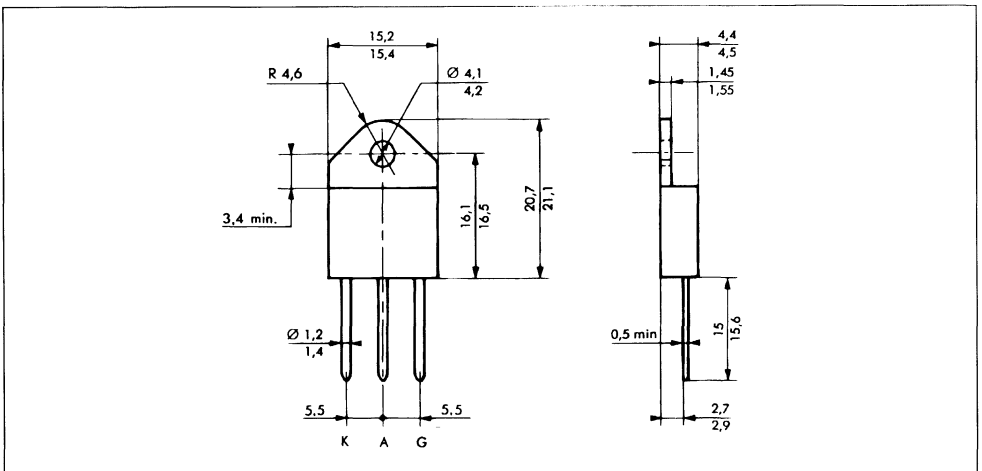

Cooling method : by conduction (method C)

Marking : type number

Weight : 5 g.



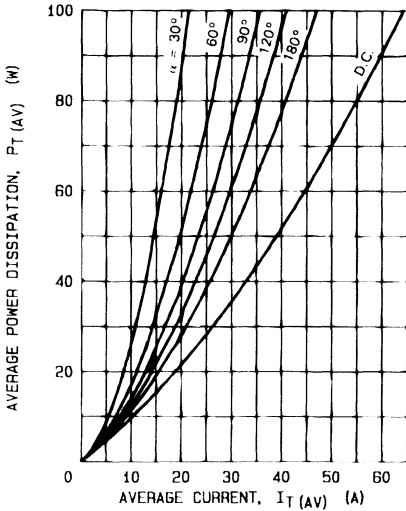
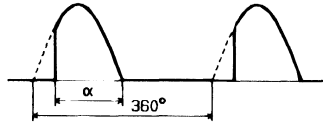

FIG.1 - MAXIMUM ON-STATE POWER DISSIPATION FOR SINUSOIDAL CURRENT WAVEFORM

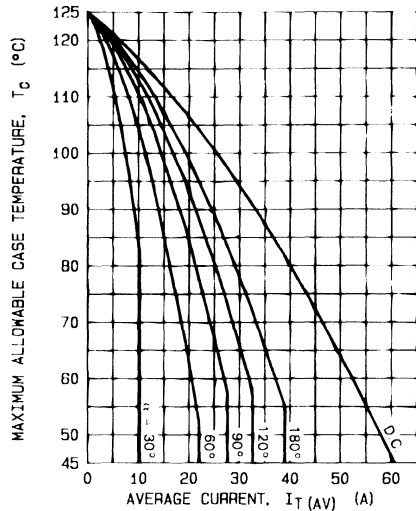

FIG.2 - MAXIMUM ALLOWABLE CASE TEMPERATURE FOR SINUSOIDAL CURRENT WAVEFORM

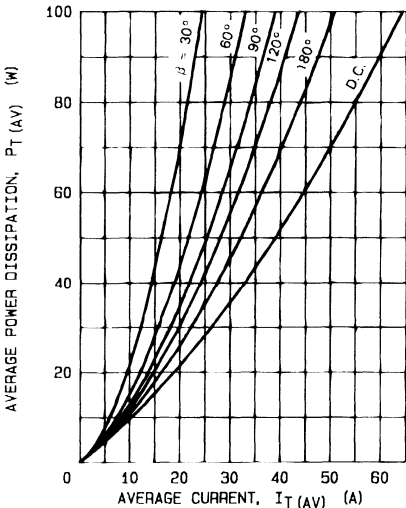
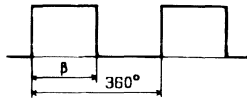

FIG.3 - MAXIMUM ON-STATE POWER DISSIPATION FOR RECTANGULAR CURRENT WAVEFORM

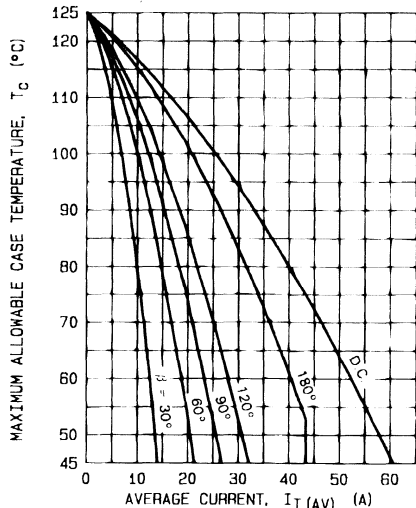

FIG.4 - MAXIMUM ALLOWABLE CASE TEMPERATURE FOR RECTANGULAR CURRENT WAVEFORM

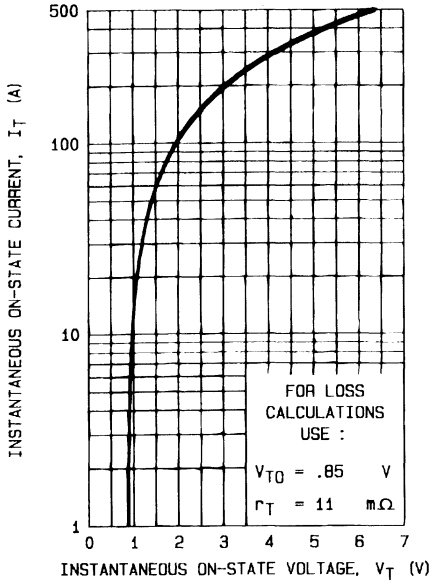

FIG.5 - MAXIMUM ON-STATE CONDUCTION CHARACTERISTIC ( $T_J = 125^\circ\text{C}$ ).

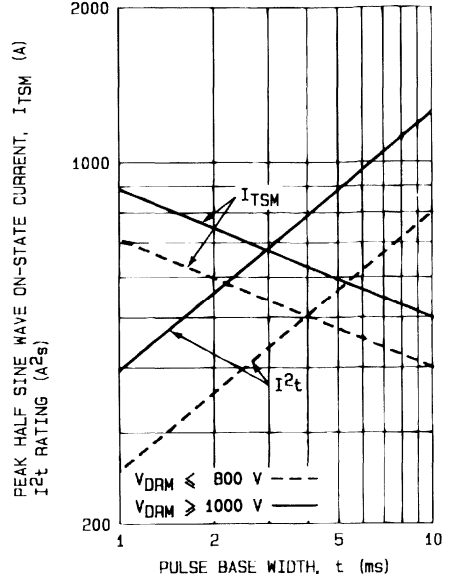

FIG.6 - NON REPETITIVE SUB-CYCLE SURGE ON-STATE CURRENT AND  $I^2t$  RATING (INITIAL  $T_J = 25^\circ\text{C}$ ).

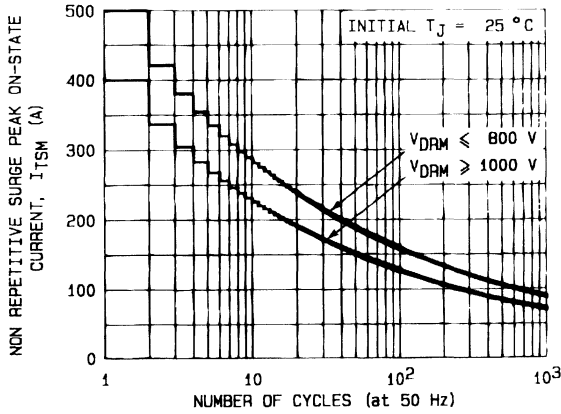
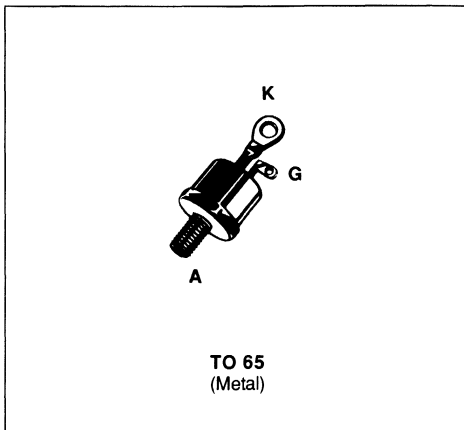

FIG.7 - NON REPETITIVE SURGE PEAK ON-STATE CURRENT VERSUS NUMBER OF CYCLES.

## FAST SWITCHING THYRISTORS

- GLASS PASSIVATED CHIP
- HIGH STABILITY AND RELIABILITY
- EXCELLENT SURGE CAPABILITY
- HIGH di/dt AND dv/dt RATINGS
- $t_q \leq 40 \mu\text{s}$



### DESCRIPTION

SCR designed for high frequency power switching applications.

### ABSOLUTE RATINGS (limiting values)

Symbol	Parameter	Value	Unit
$I_{T(RMS)}$	RMS on-state Current (1)	$T_C = 65 \text{ }^\circ\text{C}$ 63	A
$I_{T(AV)}$	Mean on-state Current (1)	$T_C = 65 \text{ }^\circ\text{C}$ 40	A
$I_{TSM}$	Non Repetitive Surge Peak on-state Current ( $T_j$ initial $\leq 125 \text{ }^\circ\text{C}$ ) (2)	$t = 8.3 \text{ ms}$ 700	A
		$t = 10 \text{ ms}$ 670	
$I^2t$	$I^2t$ Value for Fusing	$t = 10 \text{ ms}$ 2245	$\text{A}^2\text{s}$
di/dt	Critical Rate of Rise of on-state Current (3)	200	$\text{A}/\mu\text{s}$
$T_{stg}$ $T_j$	Storage and Operating Junction Temperature Range	- 40 to 150 - 40 to 125	$^\circ\text{C}$ $^\circ\text{C}$

Symbol	Parameter	TGF148-							Unit
		600B	700B	800B	900B	1000B	1100B	1200B	
$V_{DRM}$ $V_{RRM}$	Repetitive Peak off-state Voltage (4)	600	700	800	900	1000	1100	1200	V

(1) Single phase circuit,  $180^\circ$  conduction angle.

(2) Half sine wave.

(3)  $I_G = 1 \text{ A}$  di/dt =  $1 \text{ A}/\mu\text{s}$ .

(4)  $T_j = 125 \text{ }^\circ\text{C}$ .

### THERMAL RESISTANCES

Symbol	Parameter	Value	Unit
$R_{th(j-c)}$	Junction-case for D.C.	0.61	$^\circ\text{C}/\text{W}$
$R_{th(c-h)}$	Contact (case to heatsink)	0.30	$^\circ\text{C}/\text{W}$

**GATE CHARACTERISTICS** (maximum values)

$P_{GM} = 80 \text{ W}$  ( $t_p = 500 \mu\text{s}$ )       $I_{FGM} = 10 \text{ A}$  ( $t_p = 500 \mu\text{s}$ )       $V_{RGM} = 5 \text{ V}$   
 $P_{G(AV)} = 2 \text{ W}$        $V_{FGM} = 15 \text{ V}$  ( $t_p = 500 \mu\text{s}$ )

**ELECTRICAL CHARACTERISTICS**

Symbol	Test Conditions			Min.	Typ.	Max.	Unit
$I_{GT}$	$T_j = 25 \text{ }^\circ\text{C}$ Pulse Duration > 20 $\mu\text{s}$	$V_D = 12 \text{ V}$	$R_L = 33 \text{ }\Omega$			150	mA
$V_{GT}$	$T_j = 25 \text{ }^\circ\text{C}$ Pulse Duration > 20 $\mu\text{s}$	$V_D = 12 \text{ V}$	$R_L = 33 \text{ }\Omega$			1.5	V
$V_{GD}$	$T_j = 125 \text{ }^\circ\text{C}$	$V_D = V_{DRM}$	$R_L = 3.3 \text{ k}\Omega$	0.2			V
$I_H$	$T_j = 25 \text{ }^\circ\text{C}$	$I_T = 500 \text{ mA}$	Gate Open			200	mA
$I_L$	$T_j = 25 \text{ }^\circ\text{C}$ Pulse Duration > 20 $\mu\text{s}$	$V_D = 12 \text{ V}$	$I_G = 300 \text{ mA}$			400	mA
$V_{TM}$	$T_j = 25 \text{ }^\circ\text{C}$	$I_{TM} = 500 \text{ A}$	$t_p = 10 \text{ ms}$			4	V
$I_{DRM}$	$T_j = 125 \text{ }^\circ\text{C}$	$V_{DRM}$ Specified				12	mA
$I_{RRM}$	$T_j = 125 \text{ }^\circ\text{C}$	$V_{RRM}$ Specified				12	mA
$t_{gt}$	$T_j = 25 \text{ }^\circ\text{C}$ $I_G = 1 \text{ A}$	$V_D = V_{DRM}$ $di_G/dt = 10 \text{ A}/\mu\text{s}$	$I_T = 500 \text{ A}$		2		$\mu\text{s}$
$t_q$	$T_j = 125 \text{ }^\circ\text{C}$ $V_D = 67 \% V_{DRM}$ $dv/dt = 20 \text{ V}/\mu\text{s}$	$I_T = 500 \text{ A}$ $di/dt = 30 \text{ A}/\mu\text{s}$ Gate Open	$V_R = 50 \text{ V}$			40	$\mu\text{s}$
$dv/dt^*$	$T_j = 125 \text{ }^\circ\text{C}$ Linear Slope up to $V_D = 67 \% V_{DRM}$	Gate Open		200			V/ $\mu\text{s}$

\* For higher guaranteed values, please consult us.

**PACKAGE MECHANICAL DATA**

TO 65 Metal

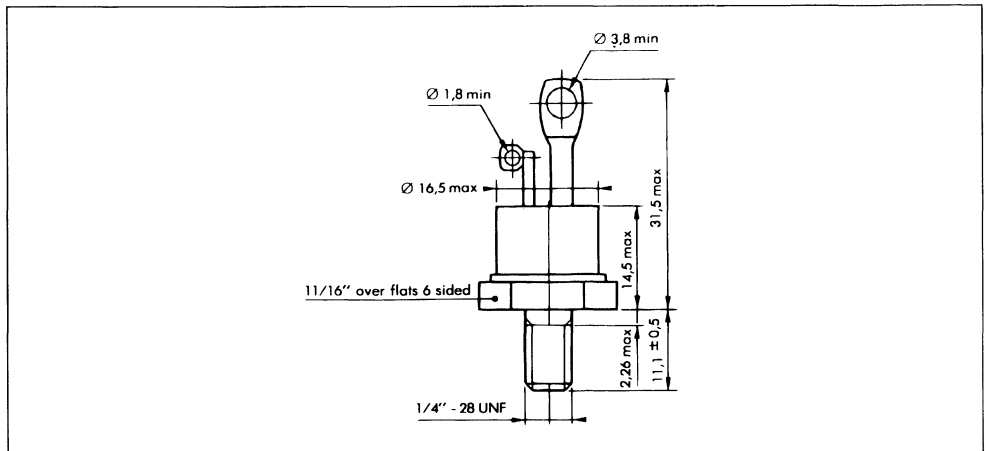

Cooling method : by conduction (method C)  
 Marking : type number  
 Weight : 19 g without accessories  
 Polarity : anode to case  
 Stud torque : 3.5 mAN min - 3.8 mAN max.

SINUSOIDAL CURRENT PULSE DATA

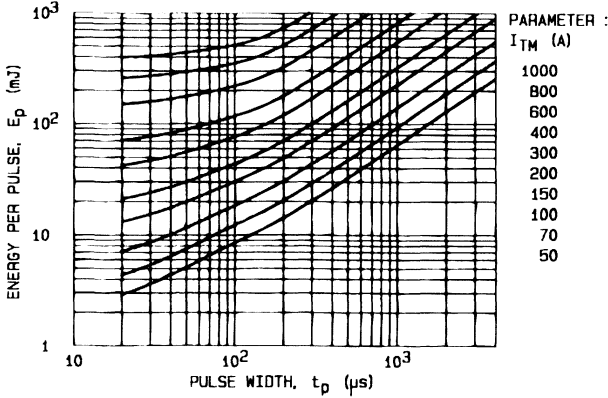

FIG.1 - ENERGY PER PULSE FOR SINUSOIDAL PULSES.

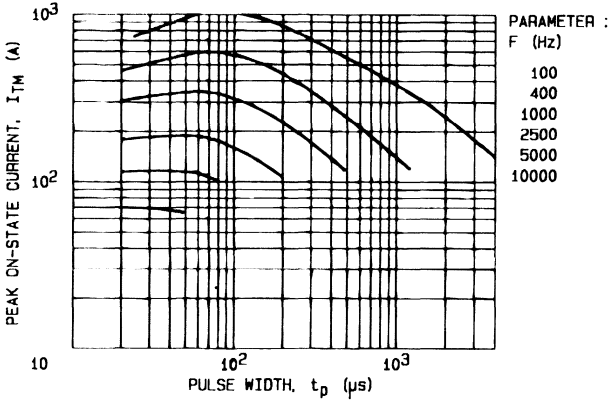

FIG.2 - MAXIMUM ALLOWABLE PEAK ON-STATE CURRENT VERSUS PULSE WIDTH FOR  $T_c = 85^\circ\text{C}$ .

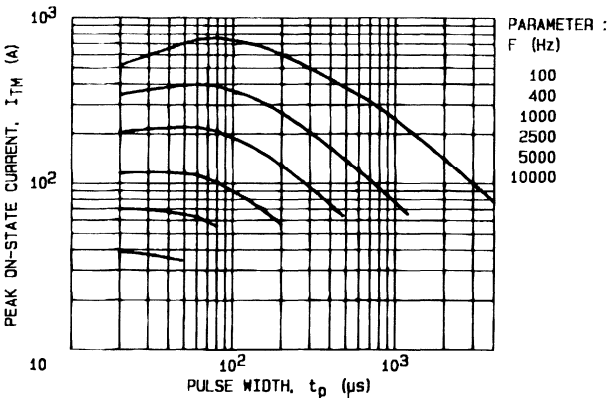
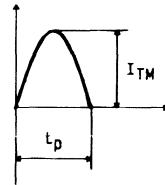

FIG.3 - MAXIMUM ALLOWABLE PEAK ON-STATE CURRENT VERSUS PULSE WIDTH FOR  $T_c = 80^\circ\text{C}$ .

NOTES :

1.  $V_D = V_R = 600$  Volts.
2. R.C Snubber,  $C = 0.1\mu\text{F}$ ,  
 $R = 33\Omega$ .

TRAPEZOIDAL CURRENT PULSE DATA

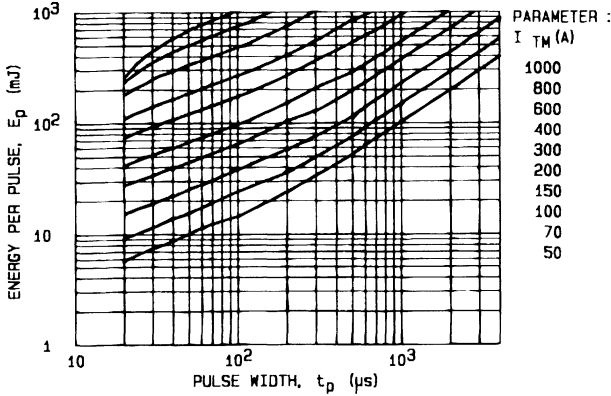
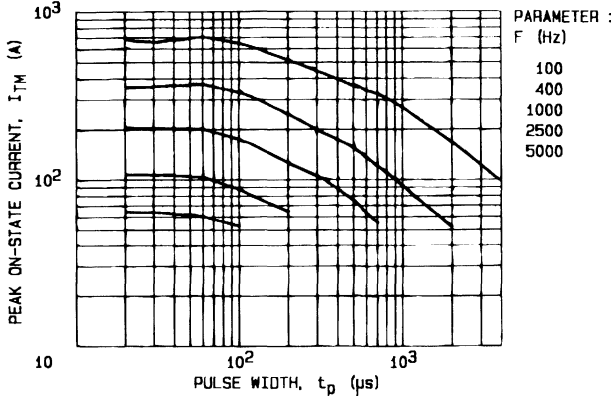

FIG. 4 - ENERGY PER PULSE FOR TRAPEZOIDAL PULSES.



$di/dt = 100 \text{ A}/\mu\text{s}$

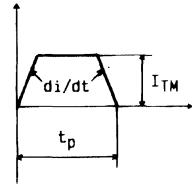
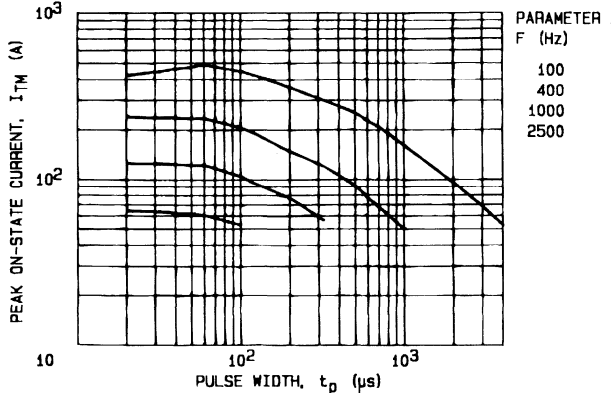

FIG. 5 - MAXIMUM ALLOWABLE PEAK ON-STATE CURRENT VERSUS PULSE WIDTH FOR  $T_0 = 85 \text{ }^\circ\text{C}$ .



NOTES :

1.  $V_D = V_R = 600 \text{ Volts}$ .
2. R.C Snubber,  $C = 0.1 \mu\text{F}$ ,  
 $R = 33 \Omega$ .

FIG. 6 - MAXIMUM ALLOWABLE PEAK ON-STATE CURRENT VERSUS PULSE WIDTH FOR  $T_0 = 90 \text{ }^\circ\text{C}$ .

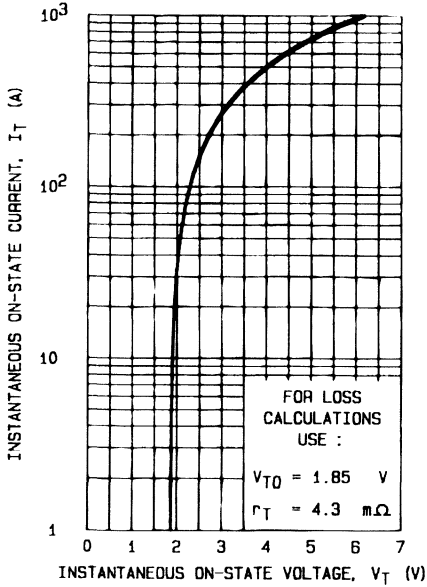

FIG.7 - MAXIMUM ON-STATE CONDUCTION CHARACTERISTIC ( $T_J = 125^\circ\text{C}$ ).

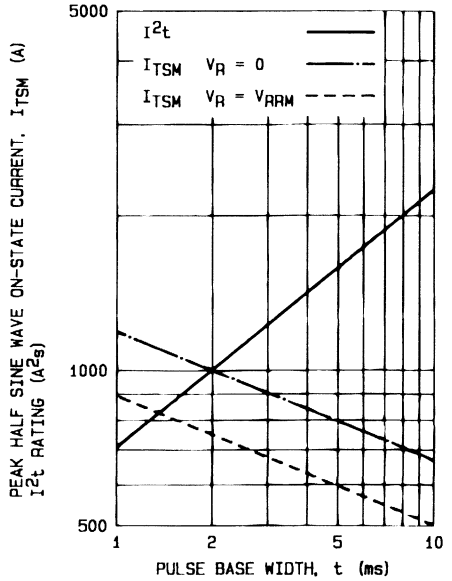

FIG.8 - NON REPETITIVE SUB-CYCLE SURGE ON-STATE CURRENT AND  $I^2t$  RATING (INITIAL  $T_J = 125^\circ\text{C}$ ).

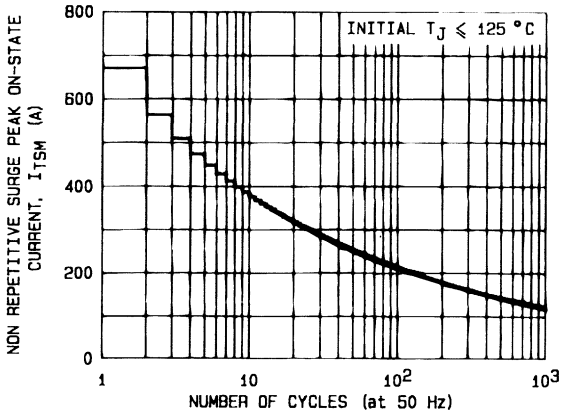

FIG.9 - NON REPETITIVE SURGE PEAK ON-STATE CURRENT VERSUS NUMBER OF CYCLES.

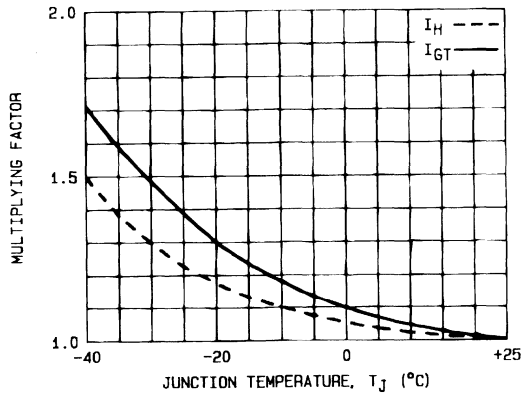

FIG. 10 - RELATIVE VARIATION OF GATE TRIGGER CURRENT AND HOLDING CURRENT VERSUS JUNCTION TEMPERATURE.

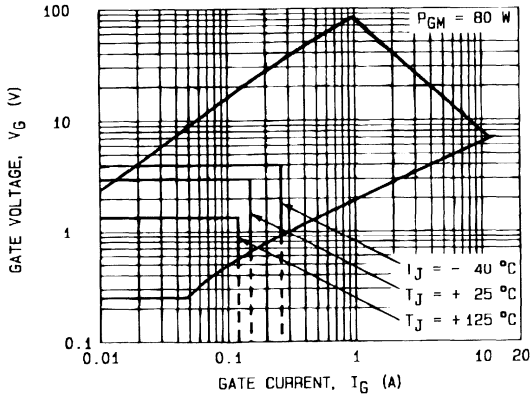

FIG. 11 - GATE TRIGGER CHARACTERISTICS.

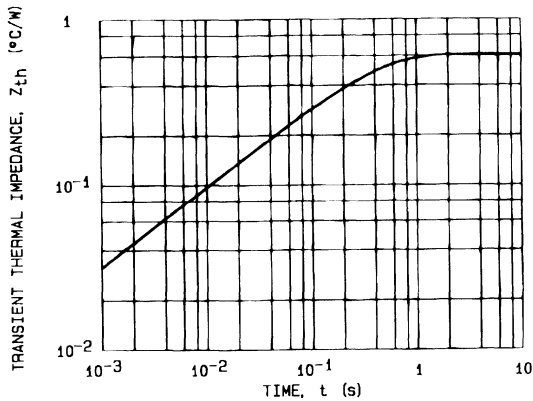
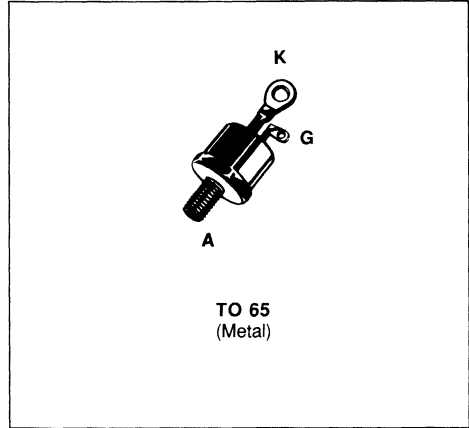

FIG. 12 - TRANSIENT THERMAL IMPEDANCE JUNCTION TO CASE.



**FAST SWITCHING THYRISTORS**

- GLASS PASSIVATED CHIP
- HIGH STABILITY AND RELIABILITY
- EXCELLENT SURGE CAPABILITY
- HIGH di/dt AND dv/dt RATINGS
- $t_q \leq 20 \mu\text{s}$

**DESCRIPTION**

SCR designed for high frequency power switching applications.

**ABSOLUTE RATINGS** (limiting values)

Symbol	Parameter		Value	Unit
$I_{T(RMS)}$	RMS on-state Current (1)	$T_C = 65^\circ\text{C}$	63	A
$I_{T(AV)}$	Mean on-state Current (1)	$T_C = 65^\circ\text{C}$	40	A
$I_{TSM}$	Non Repetitive Surge Peak on-state Current ( $T_j$ initial $\leq 125^\circ\text{C}$ ) (2)	$t = 8.3 \text{ ms}$	960	A
		$t = 10 \text{ ms}$	920	
$I^2t$	$I^2t$ Value for Fusing	$t = 10 \text{ ms}$	4230	$\text{A}^2\text{s}$
di/dt	Critical Rate of Rise of on-state Current (3)		200	A/ $\mu\text{s}$
$T_{stg}$	Storage and Operating Junction Temperature Range		- 40 to 150	$^\circ\text{C}$
$T_j$			- 40 to 125	$^\circ\text{C}$

Symbol	Parameter	TGF149-						Unit
		100A	200A	300A	400A	500A	600A	
$V_{DRM}$ $V_{RRM}$	Repetitive Peak off-state Voltage (4)	100	200	300	400	500	600	V

(1) Single phase circuit,  $180^\circ$  conduction angle.

(2) Half sine wave.

(3)  $I_G = 1 \text{ A}$      $di_G/dt = 1 \text{ A}/\mu\text{s}$ .

(4)  $T_j = 125^\circ\text{C}$ .

**THERMAL RESISTANCES**

Symbol	Parameter	Value	Unit
$R_{th(j-c)}$	Junction-case for D.C.	1.08	$^\circ\text{C}/\text{W}$
$R_{th(c-h)}$	Contact (case to heatsink)	0.30	$^\circ\text{C}/\text{W}$

**GATE CHARACTERISTICS** (maximum values)

$P_{GM} = 80 \text{ W}$  ( $t_p = 500 \mu\text{s}$ )       $I_{FGM} = 10 \text{ A}$  ( $t_p = 500 \mu\text{s}$ )       $V_{RGM} = 5 \text{ V}$   
 $P_G(AV) = 2 \text{ W}$        $V_{FGM} = 15 \text{ V}$  ( $t_p = 500 \mu\text{s}$ )

**ELECTRICAL CHARACTERISTICS**

Symbol	Test Conditions			Min.	Typ.	Max.	Unit
$I_{GT}$	$T_j = 25 \text{ }^\circ\text{C}$ Pulse Duration > 20 $\mu\text{s}$	$V_D = 12 \text{ V}$	$R_L = 33 \text{ } \Omega$			150	mA
$V_{GT}$	$T_j = 25 \text{ }^\circ\text{C}$ Pulse Duration > 20 $\mu\text{s}$	$V_D = 12 \text{ V}$	$R_L = 33 \text{ } \Omega$			1.5	V
$V_{GD}$	$T_j = 125 \text{ }^\circ\text{C}$	$V_D = V_{DRM}$	$R_L = 3.3 \text{ k}\Omega$	0.2			V
$I_H$	$T_j = 25 \text{ }^\circ\text{C}$	$I_T = 500 \text{ mA}$	Gate Open			200	mA
$I_L$	$T_j = 25 \text{ }^\circ\text{C}$ Pulse Duration > 20 $\mu\text{s}$	$V_D = 12 \text{ V}$	$I_G = 300 \text{ mA}$			400	mA
$V_{TM}$	$T_j = 25 \text{ }^\circ\text{C}$	$I_{TM} = 500 \text{ A}$	$t_p = 10 \text{ ms}$			3	V
$I_{DRM}$	$T_j = 125 \text{ }^\circ\text{C}$	$V_{DRM}$ Specified				12	mA
$I_{RRM}$	$T_j = 125 \text{ }^\circ\text{C}$	$V_{RRM}$ Specified				12	mA
$t_{gt}$	$T_j = 25 \text{ }^\circ\text{C}$ $I_G = 1 \text{ A}$	$V_D = V_{DRM}$ $di_G/dt = 10 \text{ A}/\mu\text{s}$	$I_T = 500 \text{ A}$		2		$\mu\text{s}$
$t_q$	$T_j = 125 \text{ }^\circ\text{C}$ $V_D = 67 \% V_{DRM}$ $dv/dt = 20 \text{ V}/\mu\text{s}$	$I_T = 500 \text{ A}$ $di/dt = 30 \text{ A}/\mu\text{s}$ Gate Open	$V_R = 50 \text{ V}$			20	$\mu\text{s}$
$dv/dt^*$	$T_j = 125 \text{ }^\circ\text{C}$ Linear Slope up to $V_D = 67 \% V_{DRM}$	Gate Open		200			V/ $\mu\text{s}$

\* For higher guaranteed values, please consult us.

**PACKAGE MECHANICAL DATA**

TO 65 Metal

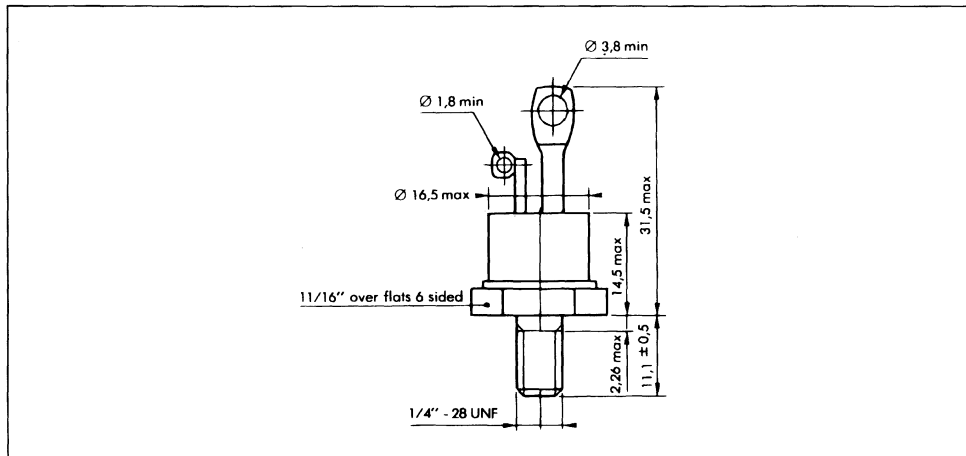

Cooling method : by conduction (method C)

Marking : type number

Weight : 19 g without accessories

Polarity : anode to case

Stud torque : 3.5 mAN min - 3.8 mAN max.

SINUSOIDAL CURRENT PULSE DATA

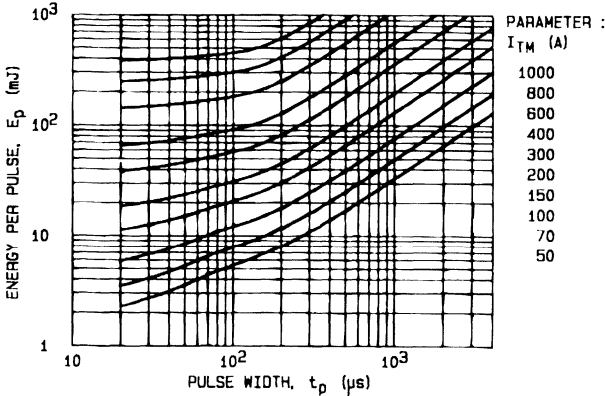

FIG. 1 - ENERGY PER PULSE FOR SINUSOIDAL PULSES.

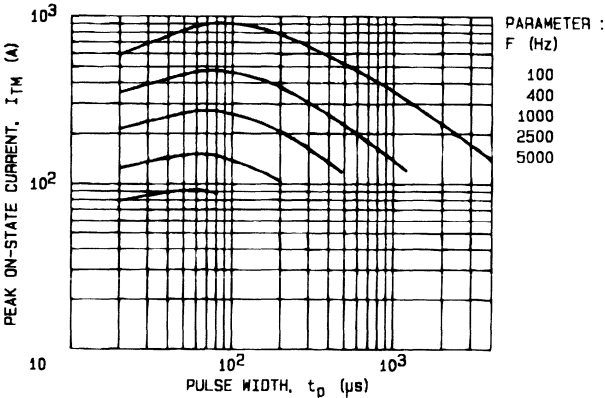

FIG. 2 - MAXIMUM ALLOWABLE PEAK ON-STATE CURRENT VERSUS PULSE WIDTH FOR  $T_c = 85^\circ\text{C}$ .

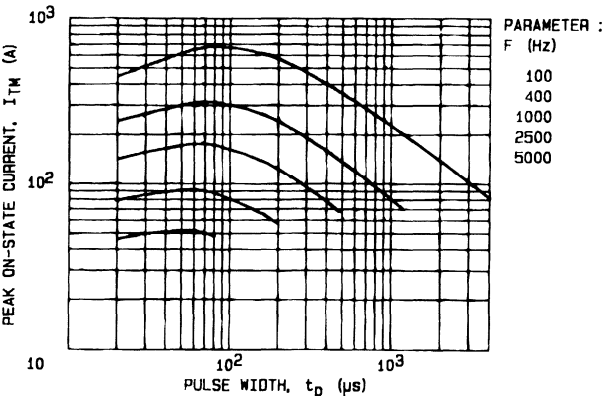
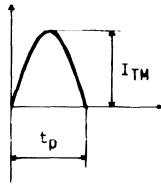

FIG. 3 - MAXIMUM ALLOWABLE PEAK ON-STATE CURRENT VERSUS PULSE WIDTH FOR  $T_c = 90^\circ\text{C}$ .

NOTES :

1.  $V_D = V_R = 300$  Volts.
2. R.C Snubber.  $C = 0.1 \mu\text{F}$ .  
 $R = 33 \Omega$ .

TRAPEZOIDAL CURRENT PULSE DATA

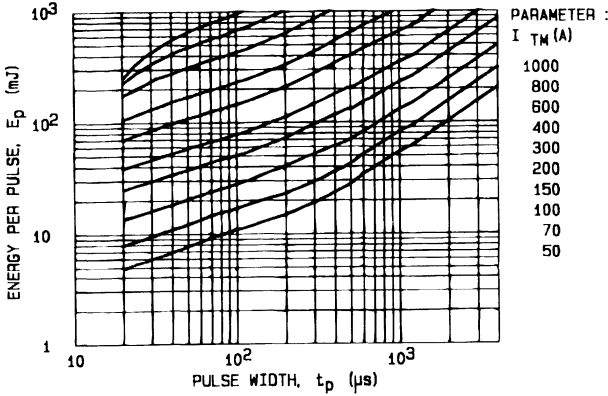

FIG.4 - ENERGY PER PULSE FOR TRAPEZOIDAL PULSES.

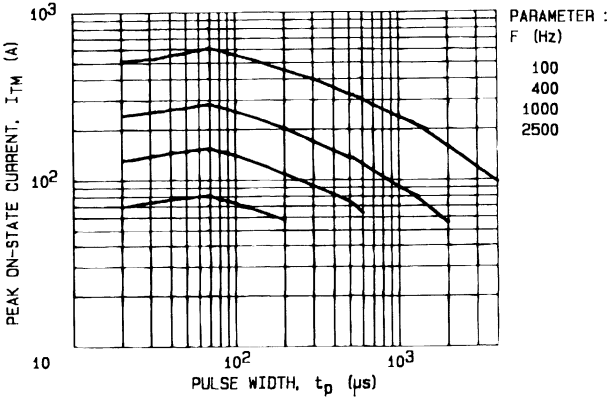

FIG.5 - MAXIMUM ALLOWABLE PEAK ON-STATE CURRENT VERSUS PULSE WIDTH FOR  $T_c = 85^\circ\text{C}$ .

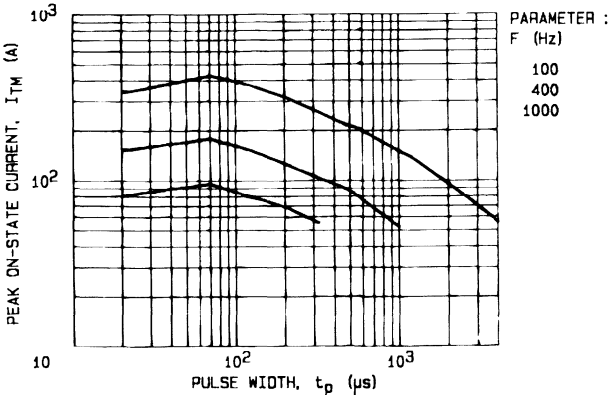
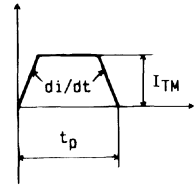

FIG.8 - MAXIMUM ALLOWABLE PEAK ON-STATE CURRENT VERSUS PULSE WIDTH FOR  $T_c = 80^\circ\text{C}$ .

$di/dt = 100 \text{ A}/\mu\text{s}$



NOTES :

1.  $V_D = V_R = 300 \text{ Volts}$ .
2. R.C Snubber,  $C = 0.1 \mu\text{F}$ ,  
 $R = 33 \Omega$ .

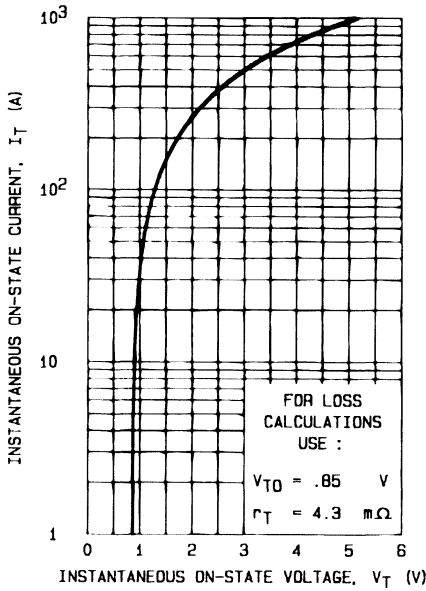

FIG.7 - MAXIMUM ON-STATE CONDUCTION CHARACTERISTIC ( $T_J = 125^\circ\text{C}$ ).

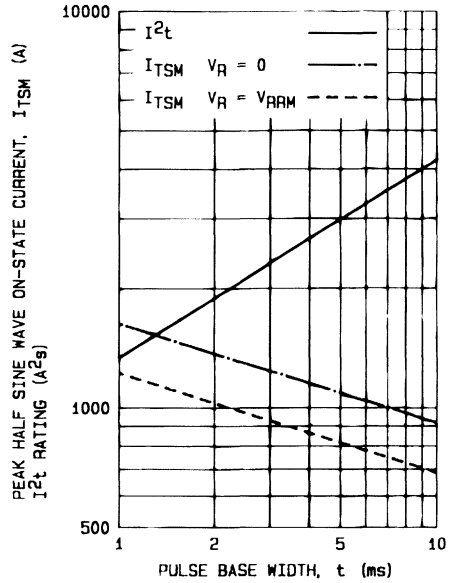

FIG.8 - NON REPETITIVE SUB-CYCLE SURGE ON-STATE CURRENT AND  $I^2t$  RATING (INITIAL  $T_J = 125^\circ\text{C}$ ).

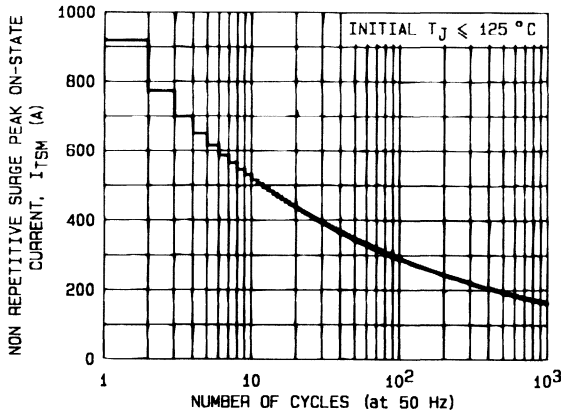

FIG.9 - NON REPETITIVE SURGE PEAK ON-STATE CURRENT VERSUS NUMBER OF CYCLES.

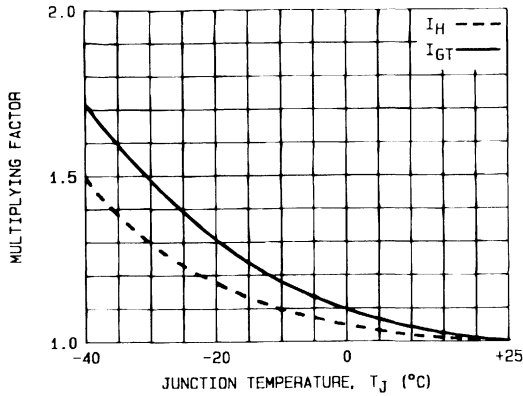

FIG.10 - RELATIVE VARIATION OF GATE TRIGGER CURRENT AND HOLDING CURRENT VERSUS JUNCTION TEMPERATURE.

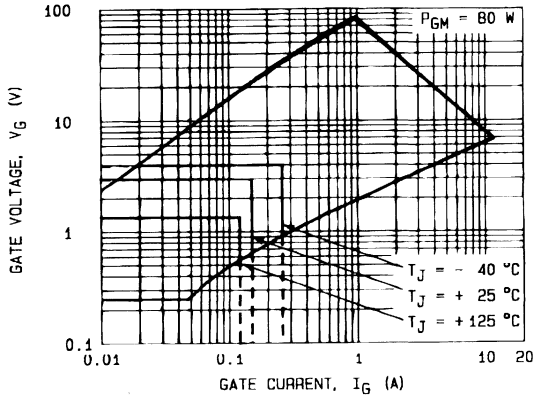

FIG.11 - GATE TRIGGER CHARACTERISTICS.

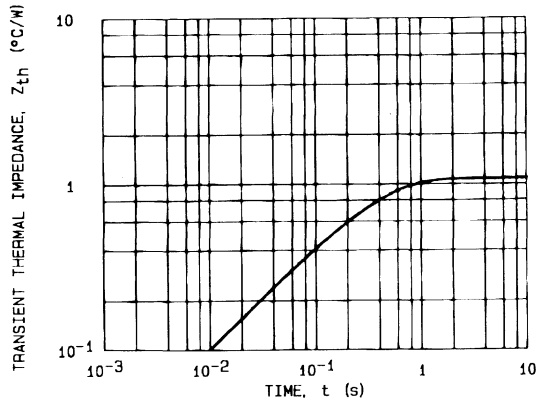
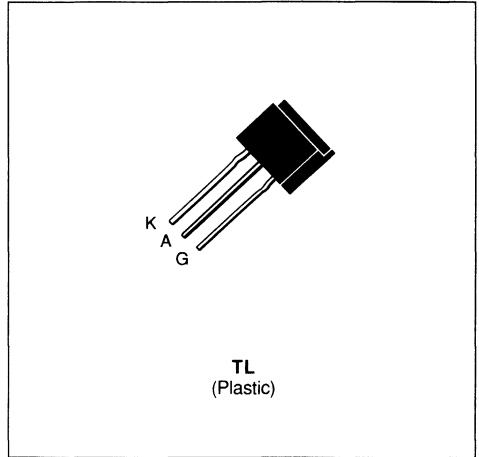

FIG.12 - TRANSIENT THERMAL IMPEDANCE JUNCTION TO CASE.



THYRISTORS

- GLASS PASSIVATED CHIP
- HIGH STABILITY AND RELIABILITY
- HIGH SURGE CAPABILITY
- HIGH ON-STATE CURRENT



**DESCRIPTION**

General purpose SCR suited for power supplies up to 400 Hz on resistive or inductive loads.

**ABSOLUTE RATINGS** (limiting values)

Symbol	Parameter		Value	Unit
$I_{T(RMS)}$	RMS on-state Current (1)	$T_I = 50\text{ }^\circ\text{C}$	3	A
$I_{T(AV)}$	Mean on-state Current (1)	$T_I = 50\text{ }^\circ\text{C}$	2	A
$I_{TSM}$	Non Repetitive Surge Peak on-state Current ( $T_j$ initial = 25 °C) (2)	$t = 8.3\text{ ms}$	73	A
		$t = 10\text{ ms}$	70	
$I^2t$	$I^2t$ Value for Fusing	$t = 10\text{ ms}$	25	A <sup>2</sup> s
$di/dt$	Critical Rate of Rise of on-state Current (3)		100	A/ $\mu$ s
$T_{stg}$ $T_j$	Storage and Operating Junction Temperature Range		- 40 to 150	°C
			- 40 to 110	°C

Symbol	Parameter	TL1006	TL2006	TL4006	TL6006	TL8006	Unit
$V_{DRM}$ $V_{RRM}$	Repetitive Peak off-state Voltage (4)	100	200	400	600	800	V

(1) Single phase circuit, 180° conduction angle.  
 (2) Half sine wave.  
 (3)  $I_G = 150\text{ mA}$   $di_G/dt = 1\text{ A}/\mu\text{s}$ .  
 (4)  $T_j = 110\text{ }^\circ\text{C}$ .

**THERMAL RESISTANCES**

Symbol	Parameter	Value	Unit
$R_{th(j-l)}$	Junction-leads	15	°C/W
$R_{th(j-a)}$	Junction-ambient on Printed Circuit (with Cu 1 cm <sup>2</sup> )	50	°C/W

**GATE CHARACTERISTICS** (maximum values)

$P_{GM} = 20 \text{ W}$  ( $t_p = 10 \mu\text{s}$ )       $I_{FGM} = 1 \text{ A}$  ( $t_p = 10 \mu\text{s}$ )       $V_{RGM} = 5 \text{ V}$   
 $P_{G(AV)} = 0.1 \text{ W}$        $V_{FGM} = 15 \text{ V}$  ( $t_p = 10 \mu\text{s}$ )

**ELECTRICAL CHARACTERISTICS**

Symbol	Test Conditions			Min.	Typ.	Max.	Unit	
$I_{GT}$	$T_j = 25 \text{ }^\circ\text{C}$ Pulse Duration > 20 $\mu\text{s}$	$V_D = 12 \text{ V}$	$R_L = 33 \text{ } \Omega$			15	mA	
$V_{GT}$	$T_j = 25 \text{ }^\circ\text{C}$ Pulse Duration > 20 $\mu\text{s}$	$V_D = 12 \text{ V}$	$R_L = 33 \text{ } \Omega$		1	1.5	V	
$V_{GD}$	$T_j = 110 \text{ }^\circ\text{C}$	$V_D = V_{DRM}$	$R_L = 3.3 \text{ k}\Omega$	0.2			V	
$I_H$	$T_j = 25 \text{ }^\circ\text{C}$	$I_T = 100 \text{ mA}$	Gate Open		20		mA	
$I_L$	$T_j = 25 \text{ }^\circ\text{C}$ Pulse Duration > 20 $\mu\text{s}$	$V_D = 12 \text{ V}$	$I_G = 30 \text{ mA}$		40		mA	
$V_{TM}$	$T_j = 25 \text{ }^\circ\text{C}$	$I_{TM} = 6 \text{ A}$	$t_p = 10 \text{ ms}$			1.9	V	
$I_{DRM}$	$V_{DRM}$ Specified					$T_j = 25 \text{ }^\circ\text{C}$	0.01	mA
						$T_j = 110 \text{ }^\circ\text{C}$	0.75	
$I_{RRM}$	$V_{RRM}$ Specified					$T_j = 25 \text{ }^\circ\text{C}$	0.01	mA
						$T_j = 110 \text{ }^\circ\text{C}$	0.75	
$t_{gt}$	$T_j = 25 \text{ }^\circ\text{C}$ $I_G = 100 \text{ mA}$	$V_D = V_{DRM}$ $di_G/dt = 1 \text{ A}/\mu\text{s}$	$I_T = 6 \text{ A}$		1.5		$\mu\text{s}$	
$t_q$	$T_j = 110 \text{ }^\circ\text{C}$ $V_D = 67 \% V_{DRM}$ Gate Open	$I_T = 6 \text{ A}$ $di/dt = 10 \text{ A}/\mu\text{s}$	$V_R = 10 \text{ V}$ $dv/dt = 20 \text{ V}/\mu\text{s}$		70		$\mu\text{s}$	
$dv/dt^*$	$T_j = 110 \text{ }^\circ\text{C}$ Linear Slope up to $V_D = 67 \% V_{DRM}$	Gate Open		200			V/ $\mu\text{s}$	

\* For higher guaranteed values, please consult us.

**PACKAGE MECHANICAL DATA**

TL Plastic

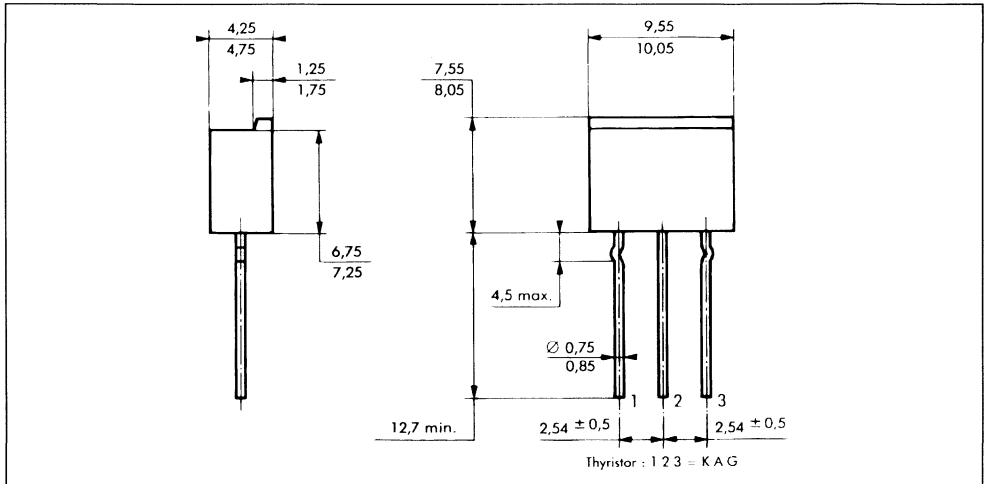



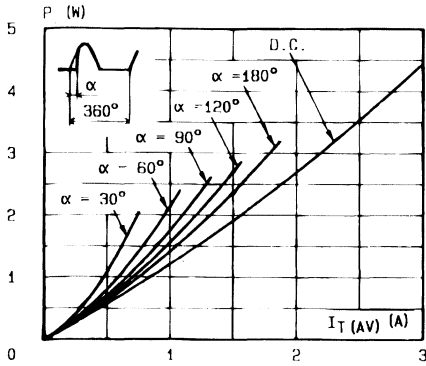

Fig.1 - Maximum mean power dissipation versus mean on-state current.

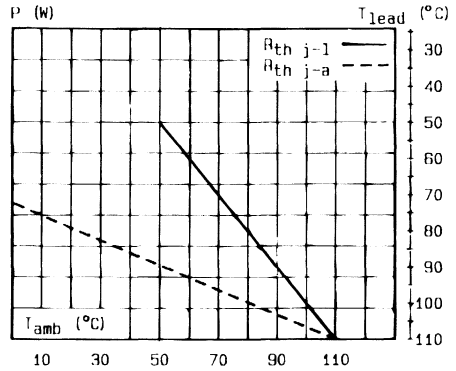

Fig.2 - Correlation between maximum mean power dissipation and maximum allowable temperatures ( $T_{amb}$  and  $T_{lead}$ ).

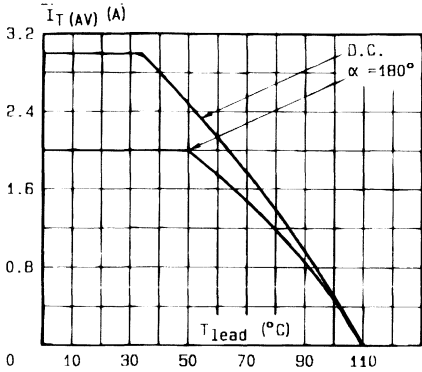

Fig.3 - Mean on-state current versus leads temperature.

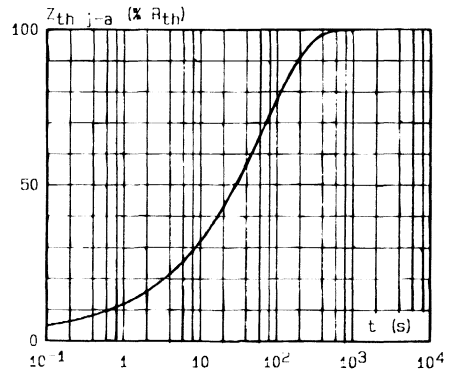

Fig.4 - Thermal transient impedance junction to ambient versus pulse duration.

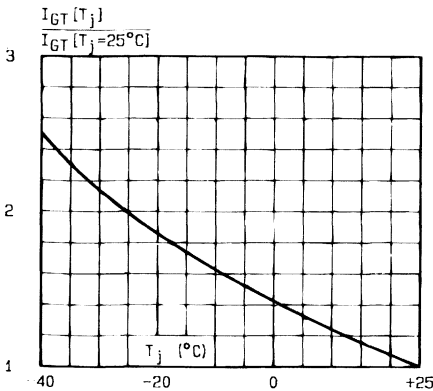

Fig.5 - Relative variation of gate trigger current versus junction temperature.

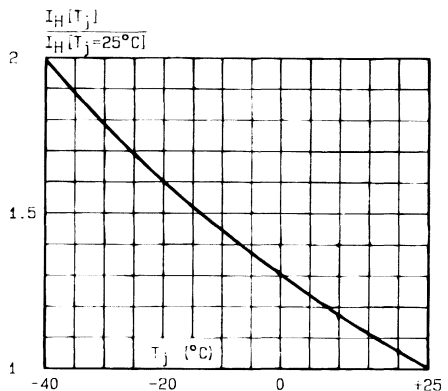

Fig.6 - Relative variation of holding current versus junction temperature.

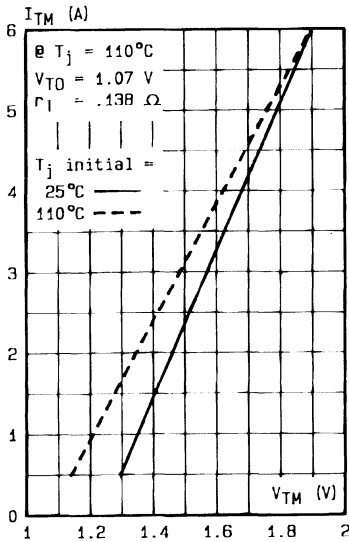

Fig.7 - On-state characteristics at low level (maximum values).

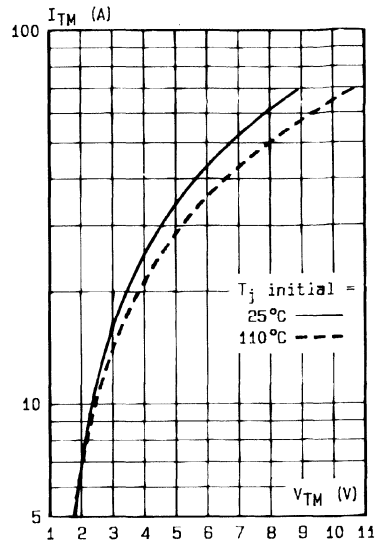

Fig.8 - On-state characteristics at high level (maximum values).

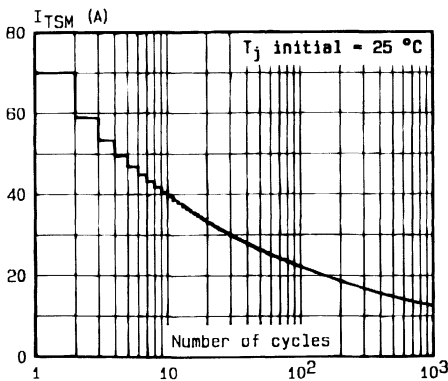

Fig.9 - Non repetitive surge peak on-state current versus number of cycles.

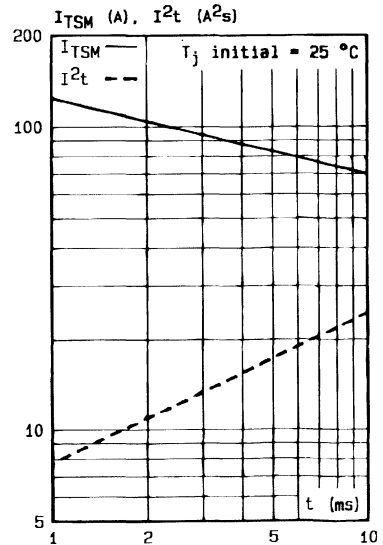
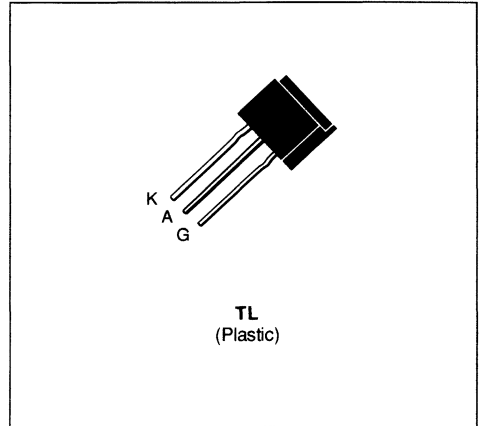

Fig.10 - Non repetitive surge peak on-state current for a sinusoidal pulse with width :  $t \leq 10\text{ ms}$ , and corresponding value of  $I^2t$ .

## SENSITIVE GATE THYRISTORS

- OPERATES DIRECTLY FROM LOW SIGNAL
- GLASS PASSIVATED CHIP
- HIGH STABILITY AND RELIABILITY
- HIGH ON-STATE CURRENT



### ABSOLUTE RATINGS (limiting values)

Symbol	Parameter		Value	Unit
$I_T (RMS)$	RMS on-state Current (1)	$T_J = 25\text{ }^\circ\text{C}$	4	A
$I_T (AV)$	Mean on-state Current (1)	$T_J = 25\text{ }^\circ\text{C}$	2.5	A
$I_{TSM}$	Non Repetitive Surge Peak on-state Current ( $T_J$ initial = $25\text{ }^\circ\text{C}$ ) (2)	$t = 8.3\text{ ms}$	37	A
		$t = 10\text{ ms}$	35	
$I^2t$	$I^2t$ Value for Fusing	$t = 10\text{ ms}$	6	$\text{A}^2\text{s}$
$di/dt$	Critical Rate of Rise of on-state Current (3)		100	$\text{A}/\mu\text{s}$
$T_{stg}$ $T_J$	Storage and Operating Junction Temperature Range		- 40 to 150 - 40 to 110	$^\circ\text{C}$ $^\circ\text{C}$

Symbol	Parameter	TLS106-.. or TLS107-..					Unit
		05	1	2	4	6	
$V_{DRM}$ $V_{RRM}$	Repetitive Peak off-state Voltage (4)	50	100	200	400	600	V

(1) Single phase circuit,  $180^\circ$  conduction angle.

(2) Half sine wave.

(3)  $I_G = 5\text{ mA}$   $di_G/dt = 1\text{ A}/\mu\text{s}$ .

(4)  $T_J = 110\text{ }^\circ\text{C}$   $R_{GK} = 1\text{ K}\Omega$ .

### THERMAL RESISTANCES

Symbol	Parameter	Value	Unit
$R_{th(j-l)}$	Junction-leads	15	$^\circ\text{C}/\text{W}$
$R_{th(j-a)}$	Junction-ambient on Printed Circuit (with Cu $1\text{ cm}^2$ )	50	$^\circ\text{C}/\text{W}$

**GATE CHARACTERISTICS** (maximum values)

$P_{GM} = 20 \text{ W}$  ( $t_p = 20 \mu\text{s}$ )

$I_{FGM} = 1 \text{ A}$  ( $t_p = 20 \mu\text{s}$ )

$V_{RGM} = 5 \text{ V}$

$P_{G(AV)} = 10 \text{ mW}$

$V_{FGM} = 15 \text{ V}$  ( $t_p = 20 \mu\text{s}$ )

**ELECTRICAL CHARACTERISTICS**

Symbol	Types	Test Conditions	Min.	Typ.	Max.	Unit
$I_{GT}$	TLS106	$T_j = 25 \text{ }^\circ\text{C}$ $V_D = 12 \text{ V}$ $R_L = 140 \text{ }\Omega$			0.2	mA
	TLS107	Pulse Duration > 20 $\mu\text{s}$			0.5	
$V_{GT}$		$T_j = 25 \text{ }^\circ\text{C}$ $V_D = 12 \text{ V}$ $R_L = 140 \text{ }\Omega$ Pulse Duration > 20 $\mu\text{s}$			1.5	V
$V_{GD}$		$T_j = 110 \text{ }^\circ\text{C}$ $V_D = V_{DRM}$ $R_L = 3.3 \text{ k}\Omega$ $R_{GK} = 1 \text{ k}\Omega$	0.1			V
$I_H$		$T_j = 25 \text{ }^\circ\text{C}$ $I_T = 50 \text{ mA}$ $R_{GK} = 1 \text{ k}\Omega$			5	mA
$I_L$		$T_j = 25 \text{ }^\circ\text{C}$ $V_D = 12 \text{ V}$ $I_G = 10 \text{ mA}$ Pulse Duration > 20 $\mu\text{s}$ $R_{GK} = 1 \text{ k}\Omega$			7	mA
$V_{TM}$		$T_j = 25 \text{ }^\circ\text{C}$ $I_{TM} = 4 \text{ A}$ $t_p = 10 \text{ ms}$			1.9	V
$I_{DRM}$		$V_{DRM}$ specified $R_{GK} = 1 \text{ k}\Omega$	$T_j = 25 \text{ }^\circ\text{C}$		0.01	mA
			$T_j = 110 \text{ }^\circ\text{C}$		0.3	
$I_{RRM}$		$V_{RRM}$ specified $R_{GK} = 1 \text{ k}\Omega$	$T_j = 25 \text{ }^\circ\text{C}$		0.01	mA
			$T_j = 110 \text{ }^\circ\text{C}$		0.3	
$t_{gt}$		$T_j = 25 \text{ }^\circ\text{C}$ $I_G = 10 \text{ mA}$ $V_D = V_{DRM}$ $I_G / dt = 0.1 \text{ A}/\mu\text{s}$	$I_T = 4 \text{ A}$	1.5		$\mu\text{s}$
$t_q$		$T_j = 110 \text{ }^\circ\text{C}$ $V_D = 67 \% V_{DRM}$ $R_{GK} = 1 \text{ k}\Omega$	$I_T = 4 \text{ A}$ $di/dt = 10 \text{ A}/\mu\text{s}$	$V_R = 10 \text{ V}$ $dv/dt = 10 \text{ V}/\mu\text{s}$	100	$\mu\text{s}$
$dv/dt^*$		$T_j = 110 \text{ }^\circ\text{C}$ $R_{GK} = 1 \text{ k}\Omega$ Linear Slope up to $V_D = 67 \% V_{DRM}$		10		V/ $\mu\text{s}$

\* For higher guaranteed values, please consult us.

**PACKAGE MECHANICAL DATA**

TL Plastic

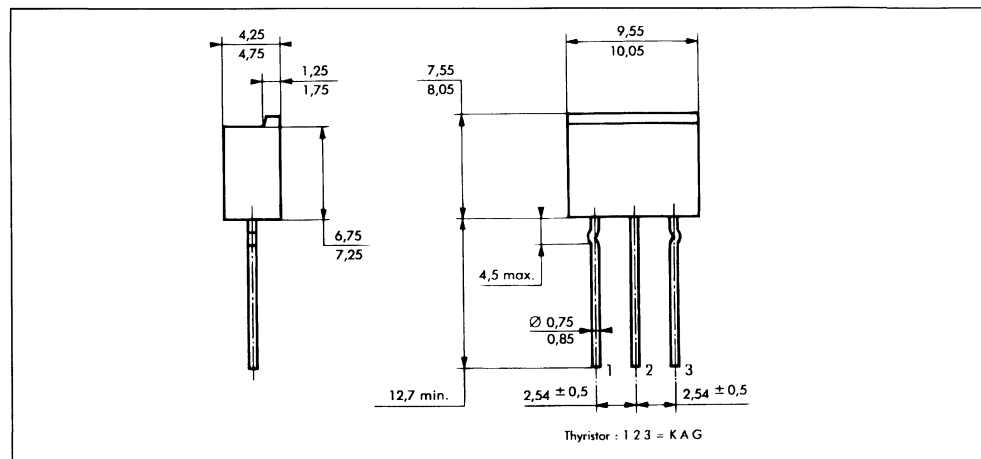

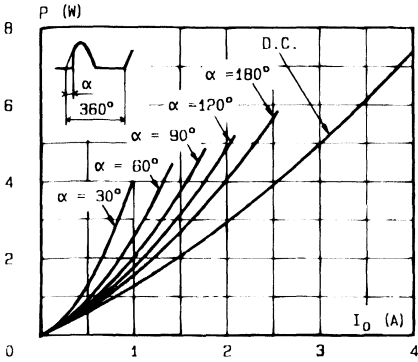

Fig. 1 - Maximum mean power dissipation versus mean on-state current.

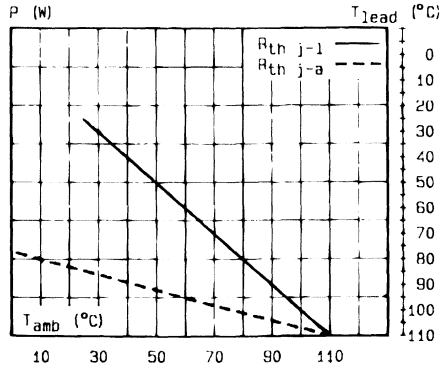

Fig. 2 - Correlation between maximum mean power dissipation and maximum allowable temperatures ( $T_{amb}$  and  $T_{lead}$ ).

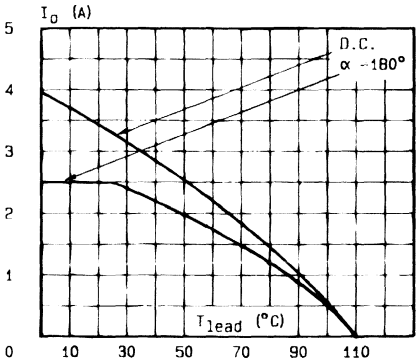

Fig. 3 - Mean on-state current versus leads temperature.

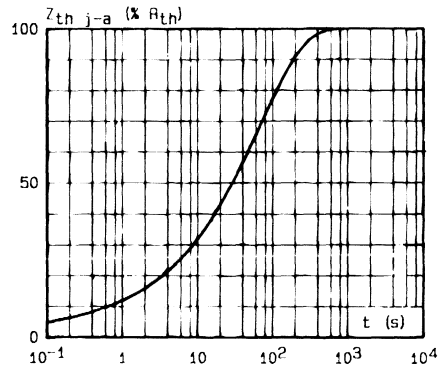

Fig. 4 - Thermal transient impedance junction to ambient versus pulse duration.

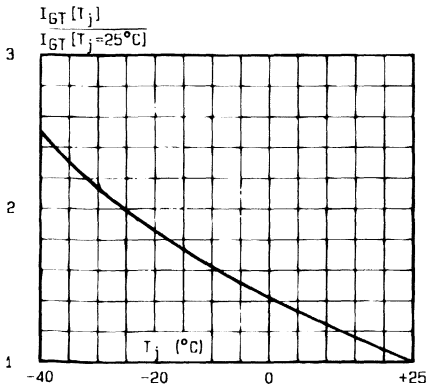

Fig. 5 - Relative variation of gate trigger current versus junction temperature.

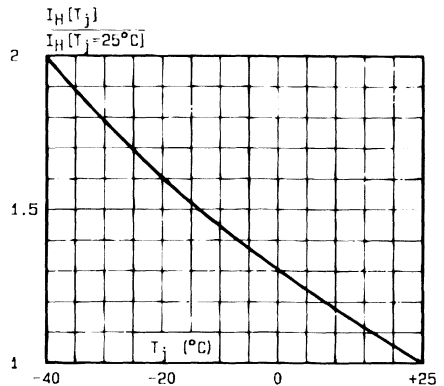

Fig. 6 - Relative variation of holding current versus junction temperature.

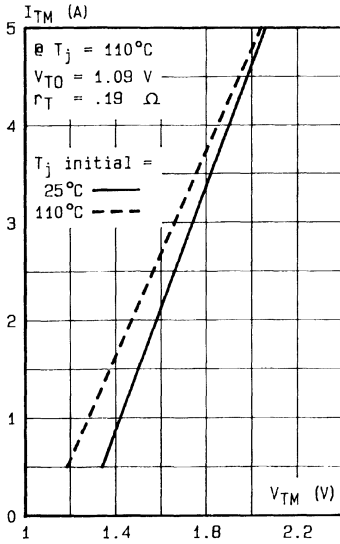

Fig.7 - On-state characteristics at low level (maximum values).

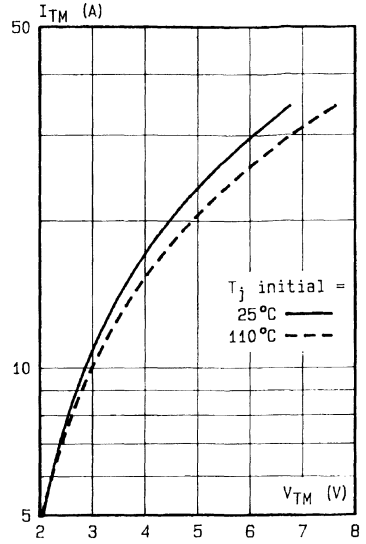

Fig.8 - On-state characteristics at high level (maximum values).

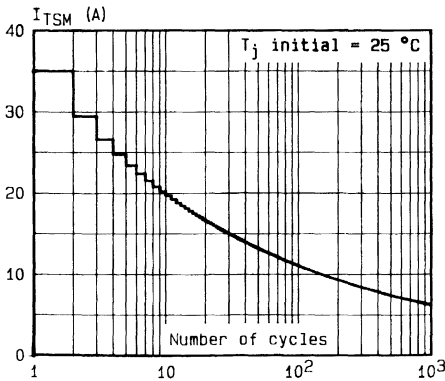

Fig.9 - Non repetitive surge peak on-state current versus number of cycles.

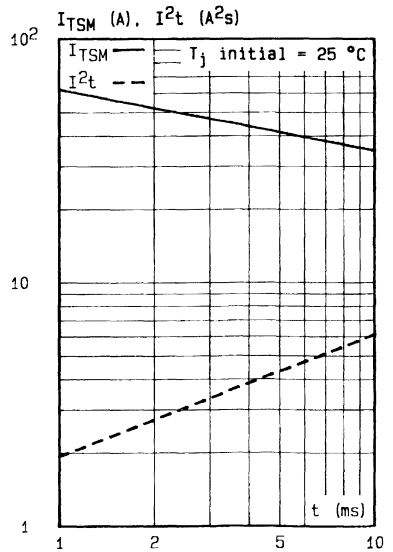

Fig.10 - Non repetitive surge peak on-state current for a sinusoidal pulse with width :  $t \leq 10\text{ ms}$ , and corresponding value of  $I^2t$ .

## THYRISTORS FOR OVERVOLTAGE PROTECTION

- GLASS PASSIVATED CHIP
- HIGH STABILITY AND RELIABILITY
- HIGH SURGE CAPABILITY

Thread : 1/4" -28 UNF : type N°  
 M6 on request : type N° + suffix M



**TO 48**  
 (Metal)

### DESCRIPTION

SCR designed for overvoltage protection in crowbar circuits.

### ABSOLUTE RATINGS (limiting values)

Symbol	Parameter		Value	Unit
$I_{T(RMS)}$	RMS on-state Current (1)	$T_c = 75\text{ }^\circ\text{C}$	25	A
$I_{T(AV)}$	Mean on-state Current (1)	$T_c = 75\text{ }^\circ\text{C}$	16	A
$I_{TSM}$	Non Repetitive Surge Peak on-state Current ( $T_j$ initial = 25 °C) (2)	$t = 8.3\text{ ms}$	733	A
		$t = 10\text{ ms}$	700	
$I^2t$	$I^2t$ Value for Fusing	$t = 10\text{ ms}$	2450	A <sup>2</sup> s
$I_{TM}$	Non Repetitive Surge Peak on-state Current ( $T_j$ initial = 25 °C) (5)	$t = 250\text{ ms}$	145	A
di/dt	Critical Rate of Rise of on-state Current (3)		100	A/ $\mu$ s
$T_{stg}$ $T_j$	Storage and Operating Junction Temperature Range		- 40 to 150	°C
			- 40 to 125	°C

Symbol	Parameter	TSP225	TSP525	TSP1025	Unit
$V_{DRM}$ $V_{RRM}$	Repetitive Peak off-state Voltage (4)	25	50	100	V

(1) Single phase circuit, 180° conduction angle.

(5) Rectangular pulse.

(2) Half sine wave.

(3)  $I_G = 500\text{ mA}$      $di_G/dt = 1\text{ A}/\mu\text{s}$ .

(4)  $T_j = 125\text{ }^\circ\text{C}$ .

### THERMAL RESISTANCES

Symbol	Parameter	Value	Unit
$R_{th(j-c)}$	Junction-case for D.C.	2.92	°C/W
$R_{th(c-h)}$	Contact (case to heatsink)	0.40	°C/W

**GATE CHARACTERISTICS** (maximum values)

$P_{GM} = 60 \text{ W}$  ( $t_p = 500 \mu\text{s}$ )       $I_{FGM} = 10 \text{ A}$  ( $t_p = 500 \mu\text{s}$ )       $V_{RGM} = 5 \text{ V}$

$P_G(AV) = 1 \text{ W}$        $V_{FGM} = 15 \text{ V}$  ( $t_p = 500 \mu\text{s}$ )

**ELECTRICAL CHARACTERISTICS**

Symbol	Test Conditions			Min.	Typ.	Max.	Unit
$I_{GT}$	$T_j = 25 \text{ }^\circ\text{C}$ Pulse Duration > 20 $\mu\text{s}$	$V_D = 12 \text{ V}$	$R_L = 33 \text{ } \Omega$			50	mA
$V_{GT}$	$T_j = 25 \text{ }^\circ\text{C}$ Pulse Duration > 20 $\mu\text{s}$	$V_D = 12 \text{ V}$	$R_L = 33 \text{ } \Omega$			1.5	V
$V_{GD}$	$T_j = 125 \text{ }^\circ\text{C}$	$V_D = V_{DRM}$	$R_L = 3.3 \text{ k}\Omega$	0.2			V
$I_H$	$T_j = 25 \text{ }^\circ\text{C}$	$I_T = 500 \text{ mA}$	Gate Open			50	mA
$I_L$	$T_j = 25 \text{ }^\circ\text{C}$ Pulse Duration > 20 $\mu\text{s}$	$V_D = 12 \text{ V}$	$I_G = 100 \text{ mA}$		50		mA
$V_{TM}$	$T_j = 25 \text{ }^\circ\text{C}$	$I_{TM} = 140 \text{ A}$	$t_p = 10 \text{ ms}$			1.5	V
	$T_j = 25 \text{ }^\circ\text{C}$	$I_{TM} = 700 \text{ A}$	$t = 10 \text{ ms}$		4		
$I_{DRM}$	$V_{DRM}$ Specified			$T_j = 25 \text{ }^\circ\text{C}$		0.01	mA
				$T_j = 125 \text{ }^\circ\text{C}$		10	
$I_{RRM}$	$V_{RRM}$ Specified			$T_j = 25 \text{ }^\circ\text{C}$		0.01	mA
				$T_j = 125 \text{ }^\circ\text{C}$		10	
$t_{gt}$	$T_j = 25 \text{ }^\circ\text{C}$ $I_G = 200 \text{ mA}$	$V_D = V_{DRM}$ $di_G/dt = 1.5 \text{ A}/\mu\text{s}$	$I_T = 140 \text{ A}$		1		$\mu\text{s}$
$t_q$	$T_j = 125 \text{ }^\circ\text{C}$ $V_D = 67 \text{ } \% V_{DRM}$ Gate Open	$I_T = 140 \text{ A}$ $di/dt = 30 \text{ A}/\mu\text{s}$	$V_R = 25 \text{ V}$ $dv/dt = 50 \text{ V}/\mu\text{s}$		50		$\mu\text{s}$
$dv/dt^*$	$T_j = 125 \text{ }^\circ\text{C}$ Linear Slope up to $V_D = 67 \text{ } \% V_{DRM}$	Gate Open		200			V/ $\mu\text{s}$

\* For higher guaranteed values, please consult us.



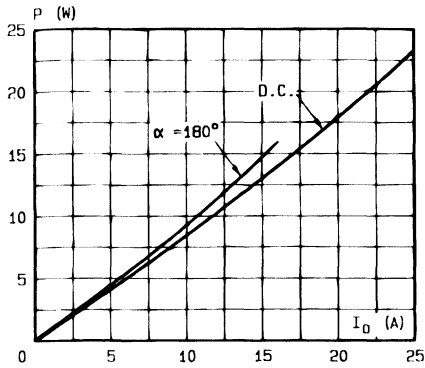

Fig.1 - Maximum average power dissipation versus average on-state current (half sine wave 50 Hz and D.C.).

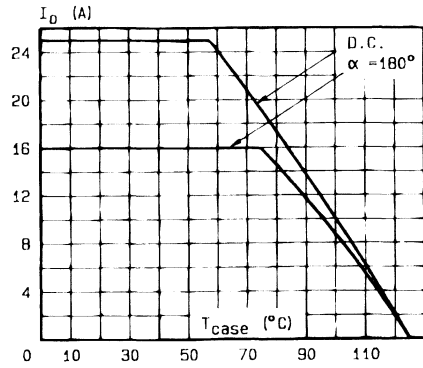

Fig.2 - Maximum average on-state current versus case temperature (half sine wave 50 Hz and D.C.).

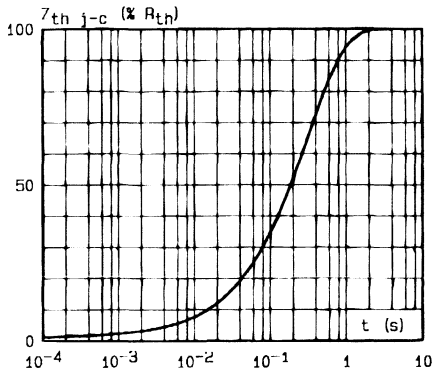

Fig.3 - Thermal transient impedance junction to case versus pulse duration.

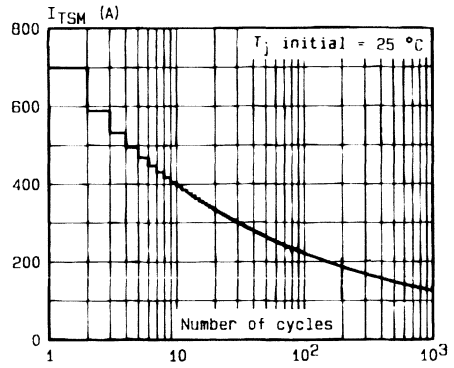

Fig.4 - Non repetitive surge peak on-state current versus number of cycles.

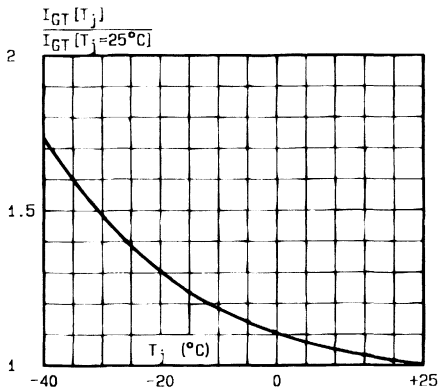

Fig.5 - Relative variation of gate trigger current versus junction temperature.

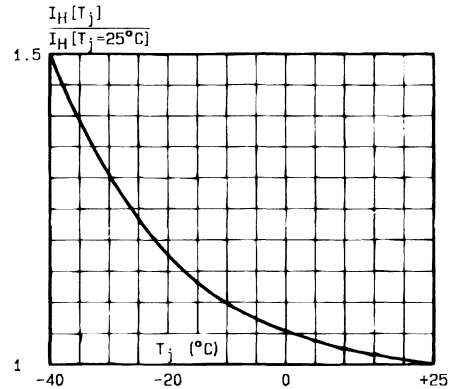

Fig.6 - Relative variation of holding current versus junction temperature.

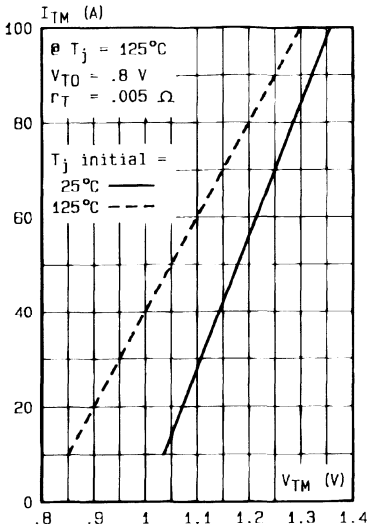

Fig.7 - On-state characteristics at low level (maximum values).

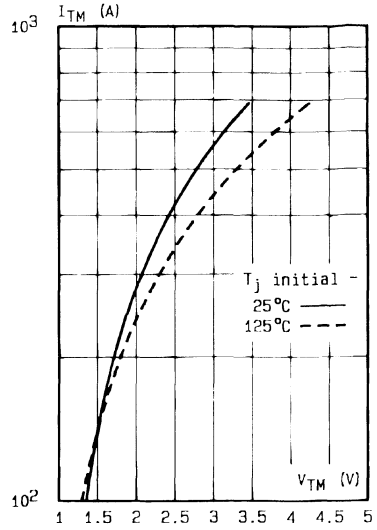

Fig.8 - On-state characteristics at high level (maximum values).

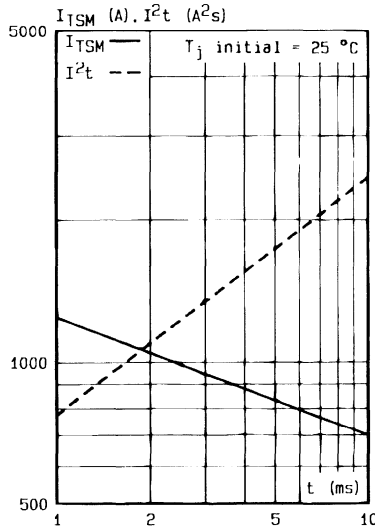

Fig.9 - Non repetitive surge peak on-state current for a sinusoidal pulse with width :  $t \leq 10 \text{ ms}$ , and corresponding value of  $I^2t$ .

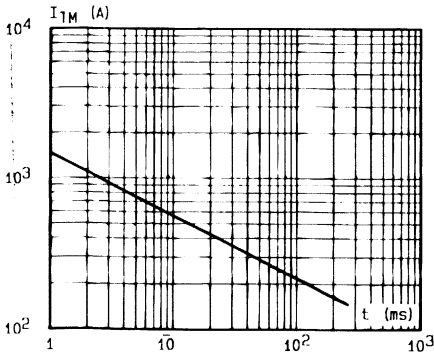

Fig.10 - Peak capacitor discharge current versus pulse width.

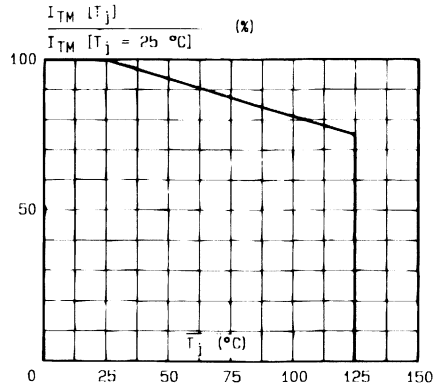
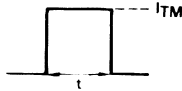
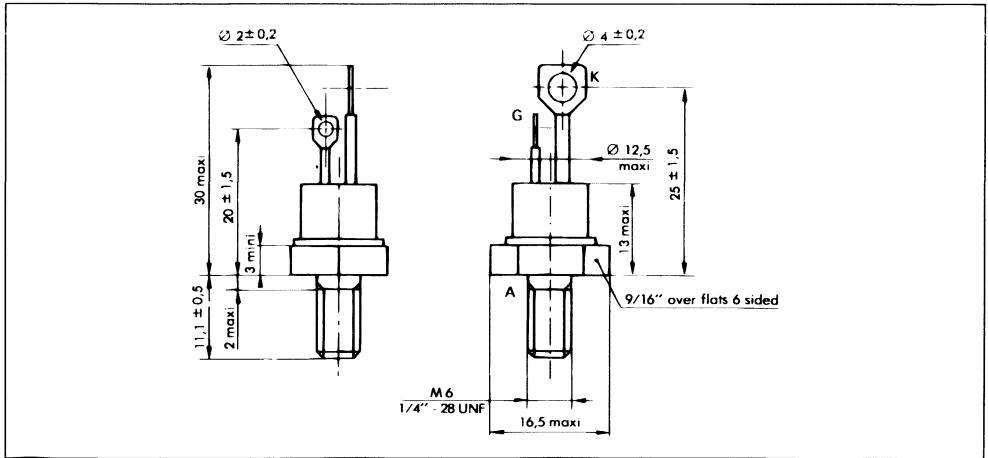

Fig.11 Allowable peak capacitor discharge current versus initial junction temperature.

**PACKAGE MECHANICAL DATA**

TO 48 Metal



Cooling method : by conduction (method C)  
 Marking : type number  
 Weight : 13.5 ± 1 g  
 Polarity : anode to case  
 Stud torque : 3.5 mAN min - 3.8 mAN max.



**THYRISTORS**

- GLASS PASSIVATED CHIP
- POSSIBILITY OF MOUNTING ON PRINTED CIRCUIT
- AVAILABLE IN NON-INSULATED VERSION → TYN SERIES OR IN INSULATED VERSION → TXN SERIES (INSULATING VOLTAGE 2500 V<sub>RMS</sub>)
- UL RECOGNIZED FOR TXN SERIES (E81734)

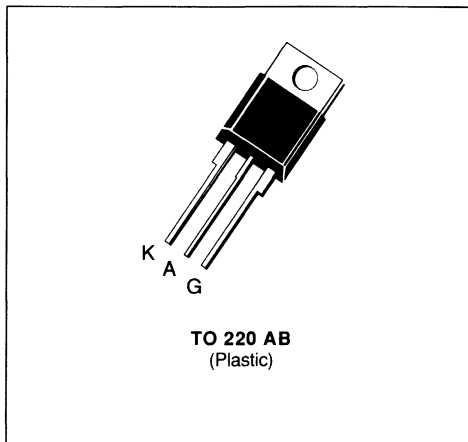
**DESCRIPTION**

SCR's designed for motor control, heating controls, power supplies...

**ABSOLUTE RATINGS** (limiting values)

Symbol	Parameter	Value	Unit
$I_{T(RMS)}$	RMS on-state Current (1)	$T_c = 90\text{ }^\circ\text{C}$ 4	A
$I_{T(AV)}$	Mean on-state Current (1)	$T_c = 90\text{ }^\circ\text{C}$ 2.5	A
$I_{TSM}$	Non Repetitive Surge Peak on-state Current ( $T_j$ initial = $25\text{ }^\circ\text{C}$ ) (2)	$t = 8.3\text{ ms}$	73
		$t = 10\text{ ms}$	70
$I^2t$	$I^2t$ Value for Fusing	$t = 10\text{ ms}$	24.5
$di/dt$	Critical Rate of Rise of on-state Current (3)	50	A/ $\mu\text{s}$
$T_{stg}$ $T_j$	Storage and Operating Junction Temperature Range	- 40 to 110 - 40 to 110	$^\circ\text{C}$ $^\circ\text{C}$

Symbol	Parameter	TXN/TYN							Unit
		054	104	204	404	604	804	1004	
$V_{DRM}$ $V_{RRM}$	Repetitive Peak off-state Voltage (4)	50	100	200	400	600	800	1000	V

(1) Single phase circuit,  $180^\circ$  conduction angle.

(2) Half sine wave.

(3)  $I_G = 150\text{ mA}$   $di_G/dt = 1\text{ A}/\mu\text{s}$ .

(4)  $T_j = 110\text{ }^\circ\text{C}$ .

**THERMAL RESISTANCES**

Symbol	Parameter	Value	Unit
$R_{th(j-c)}$	Junction-case for D.C.	5	$^\circ\text{C}/\text{W}$
$R_{th(j-a)}$	Junction-ambient	60	$^\circ\text{C}/\text{W}$

**GATE CHARACTERISTICS** (maximum values)

$P_{GM} = 20 \text{ W}$  ( $t_p = 20 \mu\text{s}$ )       $I_{FGM} = 2 \text{ A}$  ( $t_p = 20 \mu\text{s}$ )       $V_{RGM} = 5 \text{ V}$   
 $P_{G(AV)} = 0.5 \text{ W}$        $V_{FGM} = 15 \text{ V}$  ( $t_p = 20 \mu\text{s}$ )

**ELECTRICAL CHARACTERISTICS**

Symbol	Test Conditions			Min.	Typ.	Max.	Unit	
$I_{GT}$	$T_j = 25 \text{ }^\circ\text{C}$ Pulse Duration > 20 $\mu\text{s}$	$V_D = 12 \text{ V}$	$R_L = 33 \text{ }\Omega$			15	mA	
$V_{GT}$	$T_j = 25 \text{ }^\circ\text{C}$ Pulse Duration > 20 $\mu\text{s}$	$V_D = 12 \text{ V}$	$R_L = 33 \text{ }\Omega$			1.5	V	
$V_{GD}$	$T_j = 110 \text{ }^\circ\text{C}$	$V_D = V_{DRM}$	$R_L = 3.3 \text{ k}\Omega$	0.2			V	
$I_H$	$T_j = 25 \text{ }^\circ\text{C}$	$I_T = 100 \text{ mA}$	Gate Open			30	mA	
$I_L$	$T_j = 25 \text{ }^\circ\text{C}$ Pulse Duration > 20 $\mu\text{s}$	$V_D = 12 \text{ V}$	$I_G = 30 \text{ mA}$		50		mA	
$V_{TM}$	$T_j = 25 \text{ }^\circ\text{C}$	$I_{TM} = 8 \text{ A}$	$t_p = 10 \text{ ms}$			1.8	V	
$I_{DRM}$	$V_{DRM}$ Specified					$T_j = 25 \text{ }^\circ\text{C}$	0.01	mA
						$T_j = 110 \text{ }^\circ\text{C}$	1	
$I_{RRM}$	$V_{RRM}$ Specified					$T_j = 25 \text{ }^\circ\text{C}$	0.01	mA
						$T_j = 110 \text{ }^\circ\text{C}$	1	
$t_{gt}$	$T_j = 25 \text{ }^\circ\text{C}$ $I_G = 40 \text{ mA}$	$V_D = V_{DRM}$ $di_G/dt = 0.45 \text{ A}/\mu\text{s}$	$I_T = 8 \text{ A}$		2		$\mu\text{s}$	
$t_q$	$T_j = 110 \text{ }^\circ\text{C}$ $V_D = 67\% V_{DRM}$ Gate Open	$I_T = 8 \text{ A}$ $di/dt = 30 \text{ A}/\mu\text{s}$	$V_R = 25 \text{ V}$ $dv/dt = 50 \text{ V}/\mu\text{s}$		70		$\mu\text{s}$	
$dv/dt^*$	$T_j = 110 \text{ }^\circ\text{C}$ Linear Slope up to $V_D = 67\% V_{DRM}$	Gate Open		200			V/ $\mu\text{s}$	

\* For higher guaranteed values, please consult us.

**PACKAGE MECHANICAL DATA : TO 220 AB Plastic**

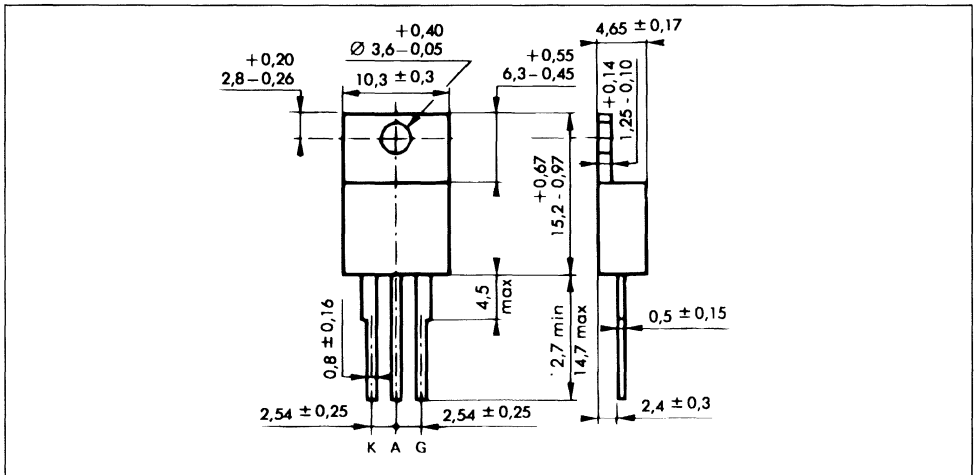

Cooling method : by conduction (method C)  
 Marking : type number  
 Weight : 2 g

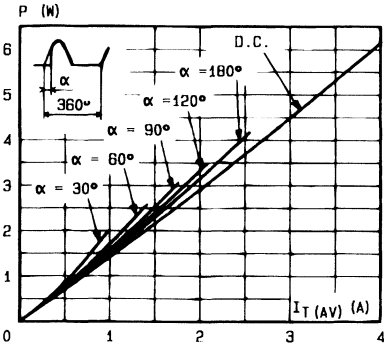

Fig. 1 - Maximum mean power dissipation versus mean on-state current.

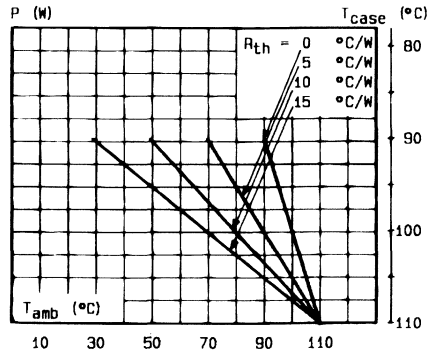

Fig. 2 - Correlation between maximum mean power dissipation and maximum allowable temperatures ( $T_{amb}$  and  $T_{case}$ ) for different thermal resistances heatsink + contact.

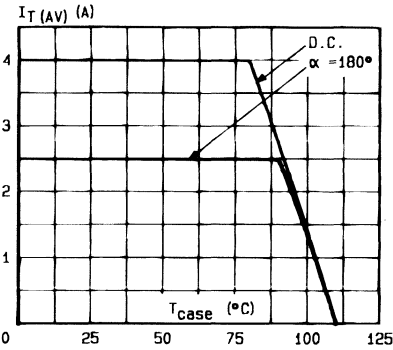

Fig. 3 - Mean on-state current versus case temperature.

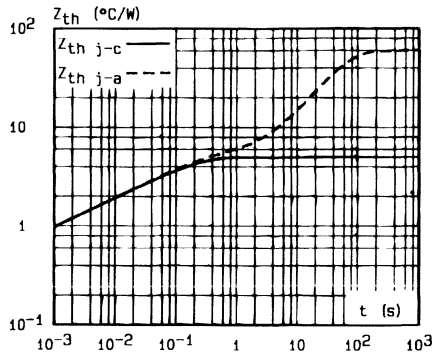

Fig. 4 - Thermal transient impedance junction to case and junction to ambient versus pulse duration.

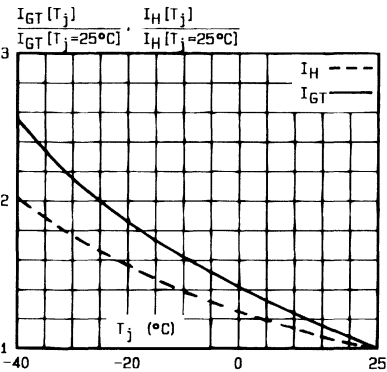

Fig. 5 - Relative variation of gate trigger current and holding current versus junction temperature.

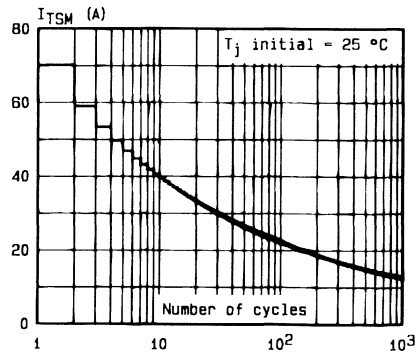

Fig. 6 - Non repetitive surge peak on-state current versus number of cycles.

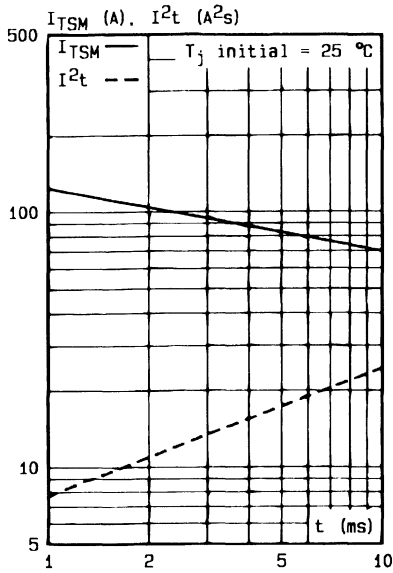

Fig.7 - Non repetitive surge peak on-state current for a sinusoidal pulse with width :  $t \leq 10$  ms, and corresponding value of  $I^2t$ .

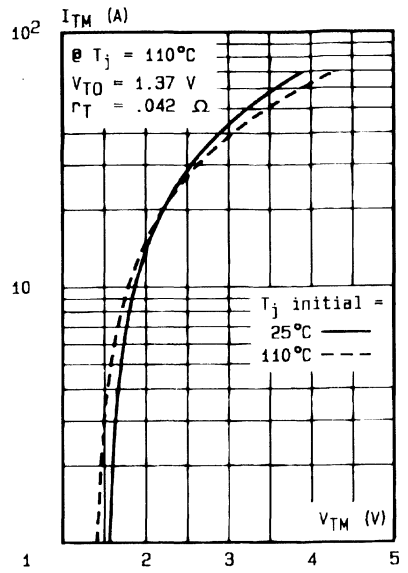

Fig.8 - On-state characteristics (maximum values).





**THYRISTORS**

- GLASS PASSIVATED CHIP
- POSSIBILITY OF MOUNTING ON PRINTED CIRCUIT
- AVAILABLE IN NON-INSULATED VERSION → TYN SERIES OR IN INSULATED VERSION → TXN SERIES (INSULATING VOLTAGE 2500 V<sub>RMS</sub>)
- UL RECOGNIZED FOR TXN SERIES (E81734)

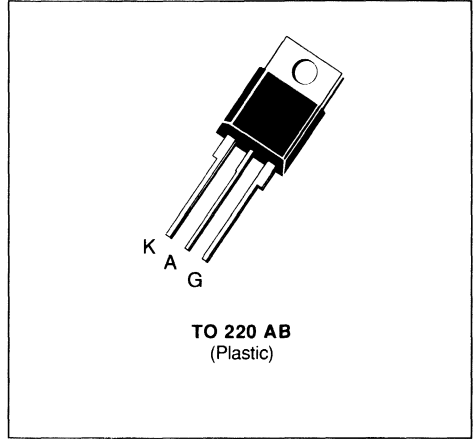

**DESCRIPTION**

SCR's designed for motor control, heating controls, power supplies...

**ABSOLUTE RATINGS** (limiting values)

Symbol	Parameter	Value	Unit
$I_{T(RMS)}$	RMS on-state Current (1)	$T_c = 80\text{ }^\circ\text{C}$ 6	A
$I_{T(AV)}$	Mean on-state Current (1)	$T_c = 80\text{ }^\circ\text{C}$ 3.8	A
$I_{TSM}$	Non Repetitive Surge Peak on-state Current ( $T_j$ initial = 25 °C) (2)	$t = 8.3\text{ ms}$	84
		$t = 10\text{ ms}$	80
$I^2t$	$I^2t$ Value for Fusing	$t = 10\text{ ms}$ 32	A <sup>2</sup> s
di/dt	Critical Rate of Rise of on-state Current (3)	50	A/ $\mu$ s
$T_{stg}$ $T_j$	Storage and Operating Junction Temperature Range	- 40 to 110 - 40 to 110	°C °C

Symbol	Parameter	TXN/TYN							Unit
		056	106	206	406	606	806	1006	
$V_{DRM}$ $V_{RRM}$	Repetitive Peak off-state Voltage (4)	50	100	200	400	600	800	1000	V

(1) Single phase circuit, 180° conduction angle.

(2) Half sine wave.

(3)  $I_G = 150\text{ mA}$      $di_G/dt = 1\text{ A}/\mu\text{s}$ .

(4)  $T_j = 110\text{ }^\circ\text{C}$ .

**THERMAL RESISTANCES**

Symbol	Parameter	Value	Unit
$R_{th(j-c)}$	Junction-case for D.C.	5	°C/W
$R_{th(j-a)}$	Junction-ambient	60	°C/W

**GATE CHARACTERISTICS** (maximum values)

$P_{GM} = 20 \text{ W}$  ( $t_p = 20 \mu\text{s}$ )       $I_{FGM} = 2 \text{ A}$  ( $t_p = 20 \mu\text{s}$ )       $V_{RGM} = 5 \text{ V}$   
 $P_{G(AV)} = 0.5 \text{ W}$        $V_{FGM} = 15 \text{ V}$  ( $t_p = 20 \mu\text{s}$ )

**ELECTRICAL CHARACTERISTICS**

Symbol	Test Conditions			Min.	Typ.	Max.	Unit
$I_{GT}$	$T_j = 25 \text{ }^\circ\text{C}$ Pulse Duration > 20 $\mu\text{s}$	$V_D = 12 \text{ V}$	$R_L = 33 \text{ } \Omega$			15	mA
$V_{GT}$	$T_j = 25 \text{ }^\circ\text{C}$ Pulse Duration > 20 $\mu\text{s}$	$V_D = 12 \text{ V}$	$R_L = 33 \text{ } \Omega$			1.5	V
$V_{GD}$	$T_j = 110 \text{ }^\circ\text{C}$	$V_D = V_{DRM}$	$R_L = 3.3 \text{ k}\Omega$	0.2			V
$I_H$	$T_j = 25 \text{ }^\circ\text{C}$	$I_T = 100 \text{ mA}$	Gate Open			30	mA
$I_L$	$T_j = 25 \text{ }^\circ\text{C}$ Pulse Duration > 20 $\mu\text{s}$	$V_D = 12 \text{ V}$	$I_G = 30 \text{ mA}$		50		mA
$V_{TM}$	$T_j = 25 \text{ }^\circ\text{C}$	$I_{TM} = 12 \text{ A}$	$t_p = 10 \text{ ms}$			1.6	V
$I_{DRM}$	$V_{DRM}$ Specified					0.01	mA
						$T_j = 110 \text{ }^\circ\text{C}$	
$I_{RRM}$	$V_{RRM}$ Specified					0.01	mA
						$T_j = 110 \text{ }^\circ\text{C}$	
$t_{gt}$	$T_j = 25 \text{ }^\circ\text{C}$ $I_G = 40 \text{ mA}$	$V_D = V_{DRM}$ $di_G/dt = 0.45 \text{ A}/\mu\text{s}$	$I_T = 12 \text{ A}$		2		$\mu\text{s}$
$t_q$	$T_j = 110 \text{ }^\circ\text{C}$ $V_D = 67 \% V_{DRM}$ Gate Open	$I_T = 12 \text{ A}$ $di/dt = 30 \text{ A}/\mu\text{s}$	$V_R = 25 \text{ V}$ $dv/dt = 50 \text{ V}/\mu\text{s}$		70		$\mu\text{s}$
$dv/dt^*$	$T_j = 110 \text{ }^\circ\text{C}$	Gate Open Linear Slope up to $V_D = 67 \% V_{DRM}$		200			V/ $\mu\text{s}$

\* For higher guaranteed values, please consult us.

**PACKAGE MECHANICAL DATA : TO 220 AB Plastic**

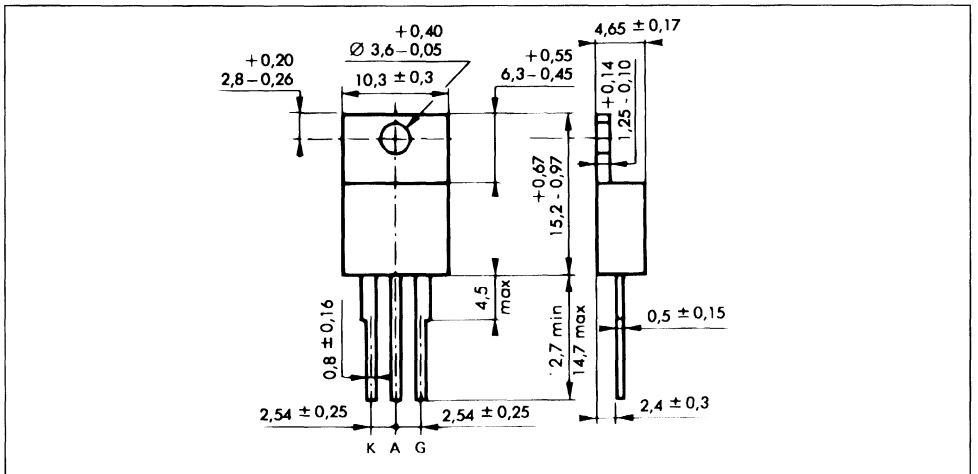

Cooling method : by conduction (method C)  
 Marking : type number  
 Weight : 2 g

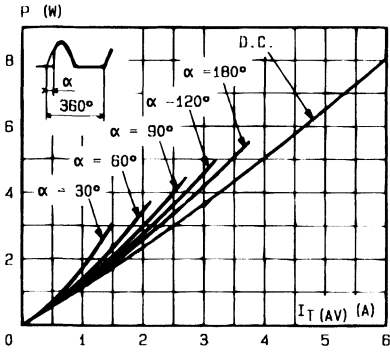

Fig. 1 - Maximum mean power dissipation versus mean on-state current.

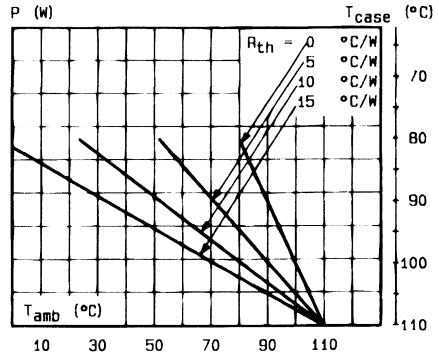

Fig. 2 - Correlation between maximum mean power dissipation and maximum allowable temperatures ( $T_{amb}$  and  $T_{case}$ ) for different thermal resistances heatsink + contact.

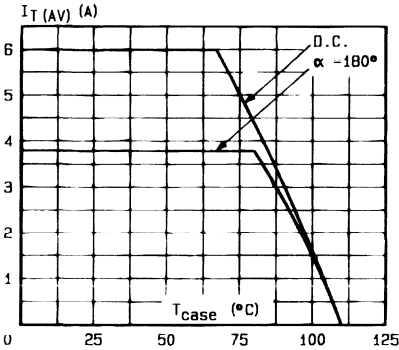

Fig. 3 - Mean on-state current versus case temperature.

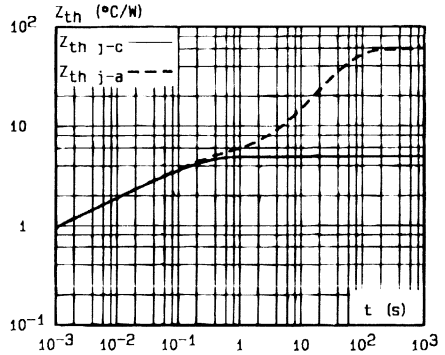

Fig. 4 - Thermal transient impedance junction to case and junction to ambient versus pulse duration.

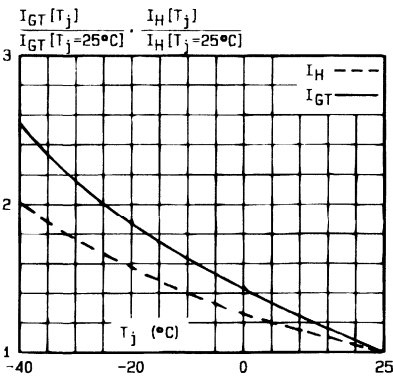

Fig. 5 - Relative variation of gate trigger current and holding current versus junction temperature.

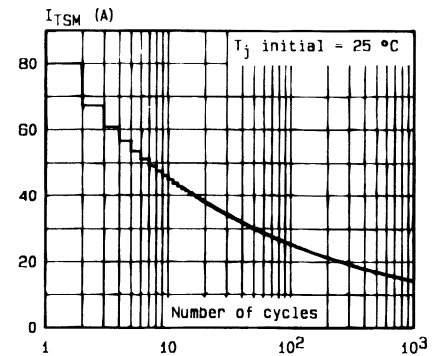

Fig. 6 - Non repetitive surge peak on-state current versus number of cycles.

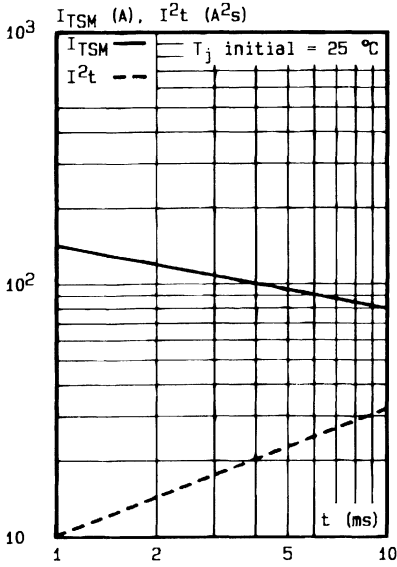

Fig. 7 - Non repetitive surge peak on-state current for a sinusoidal pulse with width :  $t \leq 10$  ms, and corresponding value of  $I^2t$ .

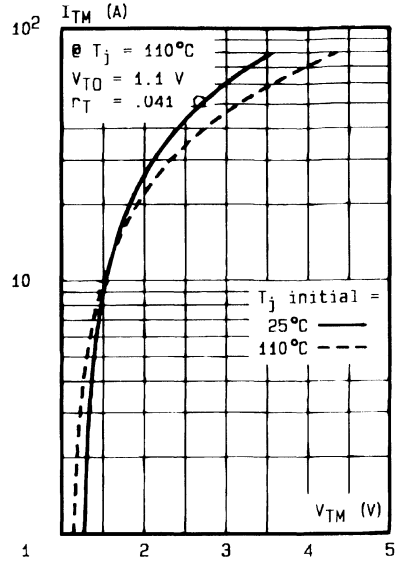
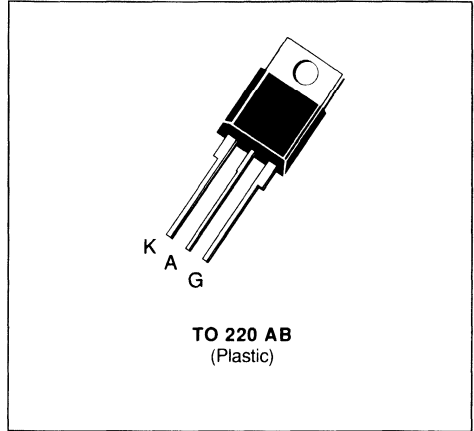

Fig. 8 - On-state characteristics (maximum values).



**THYRISTORS**

- GLASS PASSIVATED CHIP
- POSSIBILITY OF MOUNTING ON PRINTED CIRCUIT
- AVAILABLE IN NON-INSULATED VERSION → TYN SERIES OR IN INSULATED VERSION → TXN SERIES (INSULATING VOLTAGE 2500 V<sub>RMS</sub>)
- UL RECOGNIZED FOR TXN SERIES (E81734)



**DESCRIPTION**

SCR's designed for motor control, heating controls, power supplies...

**ABSOLUTE RATINGS** (limiting values)

Symbol	Parameter	Value	Unit
$I_{T(RMS)}$	RMS on-state Current (1)	$T_c = 75\text{ }^\circ\text{C}$ 8	A
$I_{T(AV)}$	Mean on-state Current (1)	$T_c = 75\text{ }^\circ\text{C}$ 5	A
$I_{TSM}$	Non Repetitive Surge Peak on-state Current ( $T_j$ initial = 25 °C) (2)	$t = 8.3\text{ ms}$	84
		$t = 10\text{ ms}$	80
$I^2t$	$I^2t$ Value for Fusing	$t = 10\text{ ms}$ 32	A <sup>2</sup> s
di/dt	Critical Rate of Rise of on-state Current (3)	50	A/μs
$T_{stg}$ $T_j$	Storage and Operating Junction Temperature Range	- 40 to 110 - 40 to 110	°C °C

Symbol	Parameter	TXN/TYN ..., G, K							Unit
		058	108	208	408	608	808	1008	
$V_{DRM}$ $V_{RRM}$	Repetitive Peak off-state Voltage (4)	50	100	200	400	600	800	1000	V

- (1) Single phase circuit, 180° conduction angle.  
 (2) Half sine wave.  
 (3)  $I_G = 400\text{ mA}$     $di_G/dt = 1\text{ A}/\mu\text{s}$ .  
 (4)  $T_j = 110\text{ }^\circ\text{C}$ .

**THERMAL RESISTANCES**

Symbol	Parameter	Value	Unit
$R_{th(j-c)}$	Junction-case for D.C.	4.7	°C/W
$R_{th(j-a)}$	Junction-ambient	60	°C/W

**GATE CHARACTERISTICS** (maximum values)

$P_{GM} = 20\text{ W}$  ( $t_p = 20\ \mu\text{s}$ )       $I_{FGM} = 2\text{ A}$  ( $t_p = 20\ \mu\text{s}$ )       $V_{RGM} = 5\text{ V}$   
 $P_{G(AV)} = 0.5\text{ W}$        $V_{FGM} = 15\text{ V}$  ( $t_p = 20\ \mu\text{s}$ )

**ELECTRICAL CHARACTERISTICS**

Symbol	Test Conditions	Min.	Typ.	Max.	Unit
$I_{GT}$	$T_j = 25\text{ }^\circ\text{C}$ $V_D = 12\text{ V}$ $R_L = 33\ \Omega$ Pulse Duration > 20 $\mu\text{s}$	Without Suffix		15	mA
		Suffix G		25	
		Suffix K		40	
$V_{GT}$	$T_j = 25\text{ }^\circ\text{C}$ $V_D = 12\text{ V}$ $R_L = 33\ \Omega$ Pulse Duration > 20 $\mu\text{s}$			1.5	V
$V_{GD}$	$T_j = 110\text{ }^\circ\text{C}$ $V_D = V_{DRM}$ $R_L = 3.3\text{ k}\Omega$	0.2			V
$I_H$	$T_j = 25\text{ }^\circ\text{C}$ $I_T = 100\text{ mA}$ Gate Open	Without Suffix		30	mA
		Suffix G		45	
		Suffix K		60	
$I_L$	$T_j = 25\text{ }^\circ\text{C}$ $V_D = 12\text{ V}$ $I_G = 80\text{ mA}$ Pulse Duration > 20 $\mu\text{s}$		50		mA
$V_{TM}$	$T_j = 25\text{ }^\circ\text{C}$ $I_{TM} = 16\text{ A}$ $t_p = 10\text{ ms}$			1.6	V
$I_{DRM}$	$V_{DRM}$ Specified	$T_j = 25\text{ }^\circ\text{C}$		0.01	mA
		$T_j = 110\text{ }^\circ\text{C}$		1	
$I_{RRM}$	$V_{RRM}$ Specified	$T_j = 25\text{ }^\circ\text{C}$		0.01	mA
		$T_j = 110\text{ }^\circ\text{C}$		1	
$t_{gt}$	$T_j = 25\text{ }^\circ\text{C}$ $V_D = V_{DRM}$ $I_G = 40\text{ mA}$ $di_G/dt = 0.45\text{ A}/\mu\text{s}$			2	$\mu\text{s}$
$t_q$	$T_j = 110\text{ }^\circ\text{C}$ $I_T = 16\text{ A}$ $V_D = 67\% V_{DRM}$ $di/dt = 30\text{ A}/\mu\text{s}$ $dv/dt = 50\text{ V}/\mu\text{s}$		70		$\mu\text{s}$
$dv/dt^*$	$T_j = 110\text{ }^\circ\text{C}$ Gate Open Linear Slope up to $V_D = 67\% V_{DRM}$	Without Suffix	200		V/ $\mu\text{s}$
		Suffix G	500		
		Suffix K	750		

\* For higher guaranteed values, please consult us.

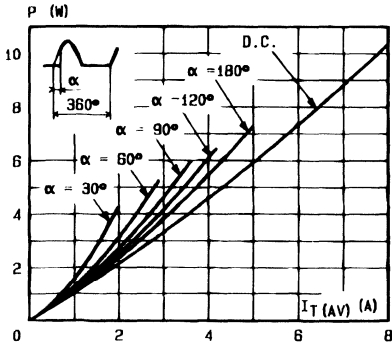

Fig. 1 - Maximum mean power dissipation versus mean on-state current.

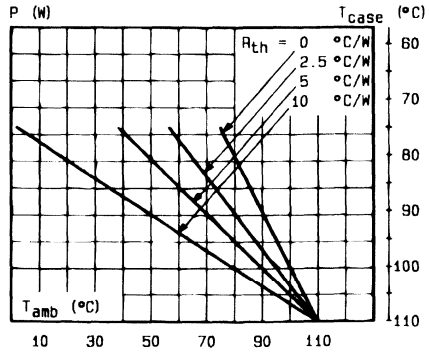

Fig. 2 - Correlation between maximum mean power dissipation and maximum allowable temperatures ( $T_{amb}$  and  $T_{case}$ ) for different thermal resistances heatsink + contact.

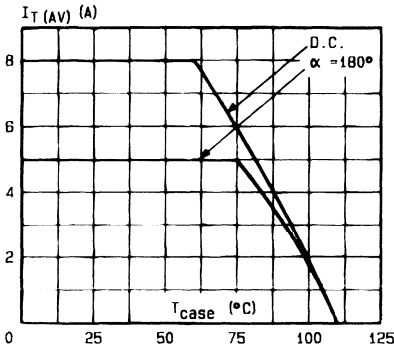

Fig. 3 - Mean on-state current versus case temperature.

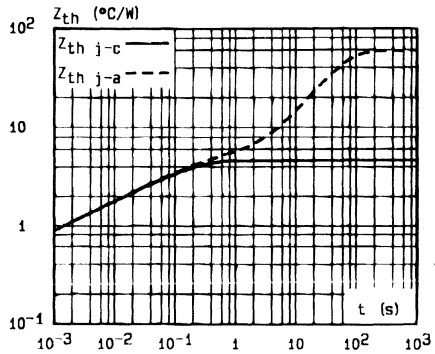

Fig. 4 - Thermal transient impedance junction to case and junction to ambient versus pulse duration.

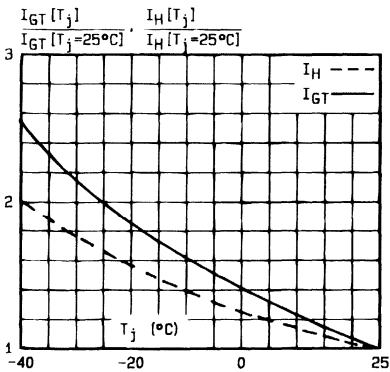

Fig. 5 - Relative variation of gate trigger current and holding current versus junction temperature.

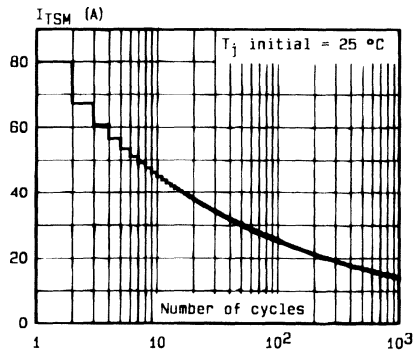

Fig. 6 - Non repetitive surge peak on-state current versus number of cycles.

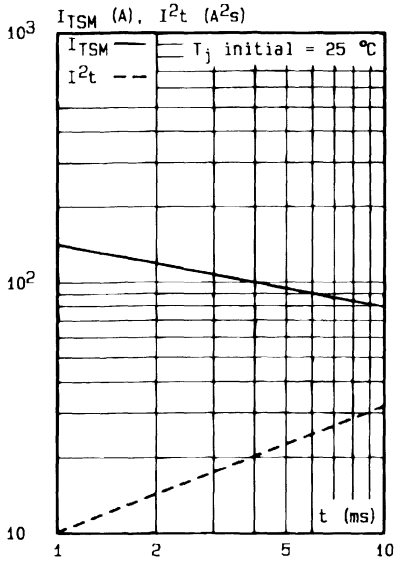

Fig. 7 - Non repetitive surge peak on-state current for a sinusoidal pulse with width :  $t \leq 10$  ms, and corresponding value of  $I^2t$ .

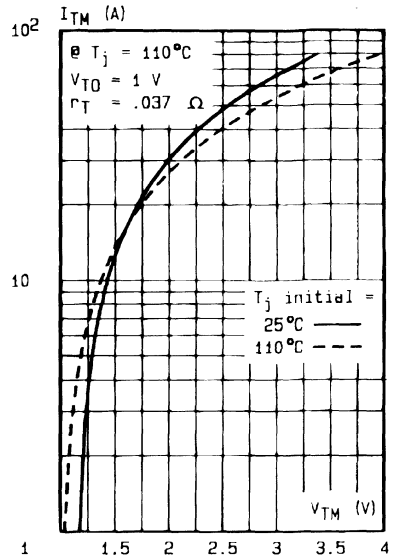
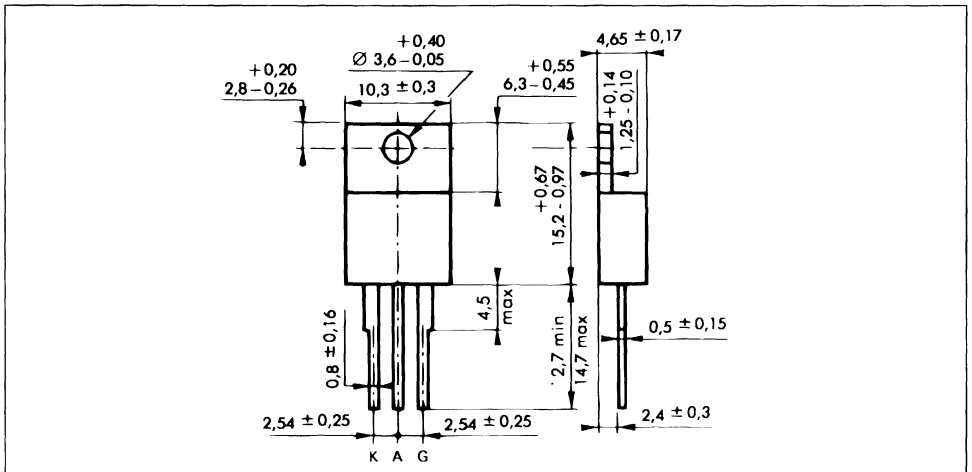

Fig. 8 - On-state characteristics (maximum values).

PACKAGE MECHANICAL DATA : TO 220 AB Plastic



Cooling method : by conduction (method C)  
 Marking : type number  
 Weight : 2 g





**THYRISTORS**

- GLASS PASSIVATED CHIP
- POSSIBILITY OF MOUNTING ON PRINTED CIRCUIT
- AVAILABLE IN NON-INSULATED VERSION → TYN SERIES OR IN INSULATED VERSION → TXN SERIES (INSULATING VOLTAGE 2500 V<sub>RMS</sub>)
- UL RECOGNIZED FOR TXN SERIES (E81734)

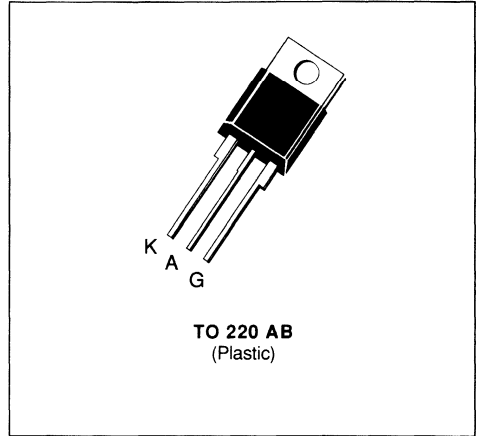

**DESCRIPTION**

SCR 's designed for motor control, heating controls, power supplies...

**ABSOLUTE RATINGS** (limiting values)

Symbol	Parameter	Value	Unit
$I_{T(RMS)}$	RMS on-state Current (1)	$T_c = 75\text{ }^\circ\text{C}$ 10	A
$I_{T(AV)}$	Mean on-state Current (1)	$T_c = 75\text{ }^\circ\text{C}$ 6.4	A
$I_{TSM}$	Non Repetitive Surge Peak on-state Current ( $T_j$ initial = 25 °C) (2)	$t = 8.3\text{ ms}$	105
		$t = 10\text{ ms}$	100
$I^2t$	$I^2t$ Value for Fusing	$t = 10\text{ ms}$ 50	A <sup>2</sup> s
$di/dt$	Critical Rate of Rise of on-state Current (3)	50	A/ $\mu$ s
$T_{stg}$ $T_j$	Storage and Operating Junction Temperature Range	- 40 to 110 - 40 to 110	$^\circ\text{C}$ $^\circ\text{C}$

Symbol	Parameter	TXN/TYN							Unit
		0510	110	210	410	610	810	1010	
$V_{DRM}$ $V_{RRM}$	Repetitive Peak off-state Voltage (4)	50	100	200	400	600	800	1000	V

(1) Single phase circuit, 180° conduction angle.

(2) Half sine wave.

(3)  $I_G = 150\text{ mA}$   $di/dt = 1\text{ A}/\mu\text{s}$ .

(4)  $T_j = 110\text{ }^\circ\text{C}$ .

**THERMAL RESISTANCES**

Symbol	Parameter	Value	Unit
$R_{th(j-c)}$	Junction-case for D.C.	3.8	$^\circ\text{C}/\text{W}$
$R_{th(j-a)}$	Junction-ambient	60	$^\circ\text{C}/\text{W}$

**GATE CHARACTERISTICS** (maximum values)

$P_{GM} = 20 \text{ W}$  ( $t_p = 20 \mu\text{s}$ )       $I_{FGM} = 2 \text{ A}$  ( $t_p = 20 \mu\text{s}$ )       $V_{RGM} = 5 \text{ V}$   
 $P_{G(AV)} = 0.5 \text{ W}$        $V_{FGM} = 15 \text{ V}$  ( $t_p = 20 \mu\text{s}$ )

**ELECTRICAL CHARACTERISTICS**

Symbol	Test Conditions			Min.	Typ.	Max.	Unit
$I_{GT}$	$T_j = 25 \text{ }^\circ\text{C}$ Pulse Duration > 20 $\mu\text{s}$	$V_D = 12 \text{ V}$	$R_L = 33 \text{ }\Omega$			15	mA
$V_{GT}$	$T_j = 25 \text{ }^\circ\text{C}$ Pulse Duration > 20 $\mu\text{s}$	$V_D = 12 \text{ V}$	$R_L = 33 \text{ }\Omega$			1.5	V
$V_{GD}$	$T_j = 110 \text{ }^\circ\text{C}$	$V_D = V_{DRM}$	$R_L = 3.3 \text{ k}\Omega$	0.2			V
$I_H$	$T_j = 25 \text{ }^\circ\text{C}$	$I_T = 100 \text{ mA}$	Gate Open			30	mA
$I_L$	$T_j = 25 \text{ }^\circ\text{C}$ Pulse Duration > 20 $\mu\text{s}$	$V_D = 12 \text{ V}$	$I_G = 30 \text{ mA}$		50		mA
$V_{TM}$	$T_j = 25 \text{ }^\circ\text{C}$	$I_{TM} = 20 \text{ A}$	$t_p = 10 \text{ ms}$			1.6	V
$I_{DRM}$	$V_{DRM}$ Specified			$T_j = 25 \text{ }^\circ\text{C}$		0.01	mA
				$T_j = 110 \text{ }^\circ\text{C}$		1	
$I_{RRM}$	$V_{RRM}$ Specified			$T_j = 25 \text{ }^\circ\text{C}$		0.01	mA
				$T_j = 110 \text{ }^\circ\text{C}$		1	
$t_{gt}$	$T_j = 25 \text{ }^\circ\text{C}$ $I_G = 40 \text{ mA}$	$V_D = V_{DRM}$ $di_G/dt = 0.45 \text{ A}/\mu\text{s}$	$I_T = 20 \text{ A}$		2		$\mu\text{s}$
$t_q$	$T_j = 110 \text{ }^\circ\text{C}$ $V_D = 67 \% V_{DRM}$ Gate Open	$I_T = 20 \text{ A}$ $di/dt = 30 \text{ A}/\mu\text{s}$	$V_R = 25 \text{ V}$ $dv/dt = 50 \text{ V}/\mu\text{s}$		70		$\mu\text{s}$
$dv/dt^*$	$T_j = 110 \text{ }^\circ\text{C}$ Linear Slope up to $V_D = 67 \% V_{DRM}$	Gate Open		200			V/ $\mu\text{s}$

\* For higher guaranteed values, please consult us.

**PACKAGE MECHANICAL DATA : TO 220 AB Plastic**

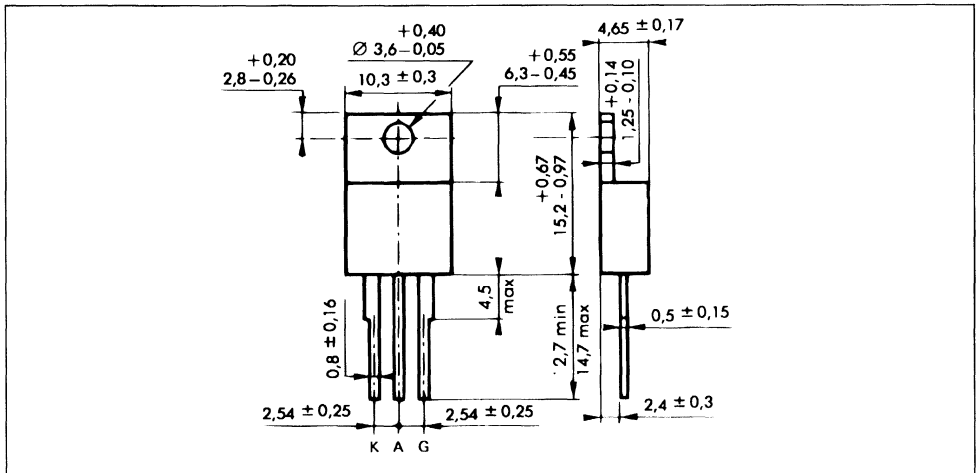

Cooling method : by conduction (method C)  
 Marking : type number  
 Weight : 2 g

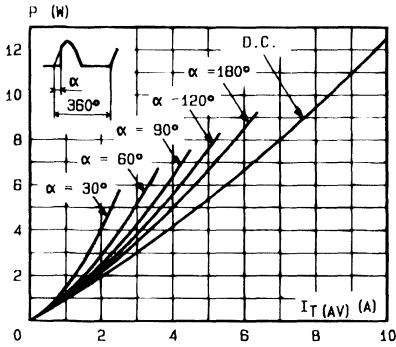

Fig. 1 - Maximum mean power dissipation versus mean on-state current.

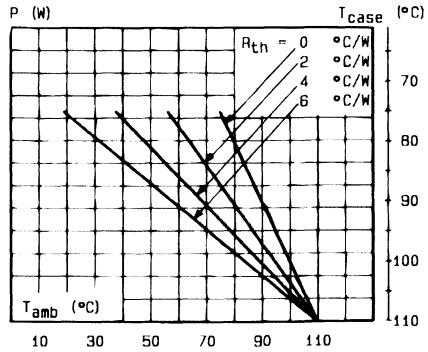

Fig. 2 - Correlation between maximum mean power dissipation and maximum allowable temperatures ( $T_{amb}$  and  $T_{case}$ ) for different thermal resistances heatsink + contact.

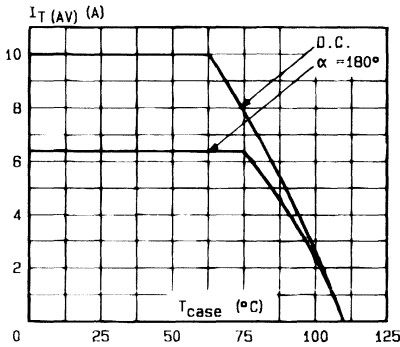

Fig. 3 - Mean on-state current versus case temperature.

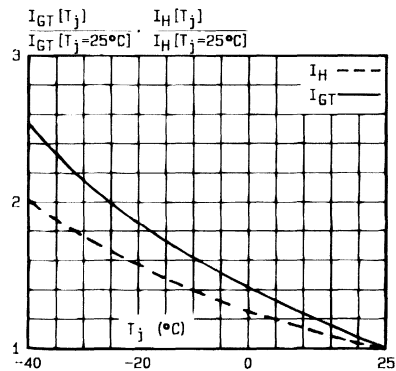

Fig. 5 - Relative variation of gate trigger current and holding current versus junction temperature.

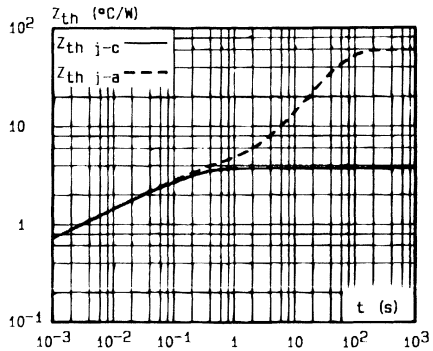

Fig. 4 - Thermal transient impedance junction to case and junction to ambient versus pulse duration.

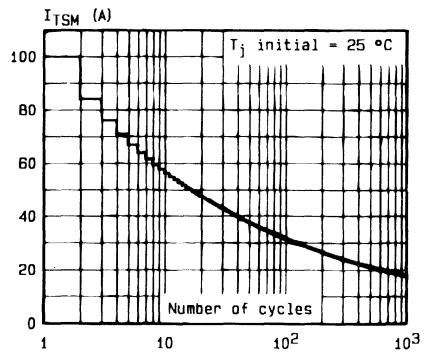

Fig. 6 - Non repetitive surge peak on-state current versus number of cycles.

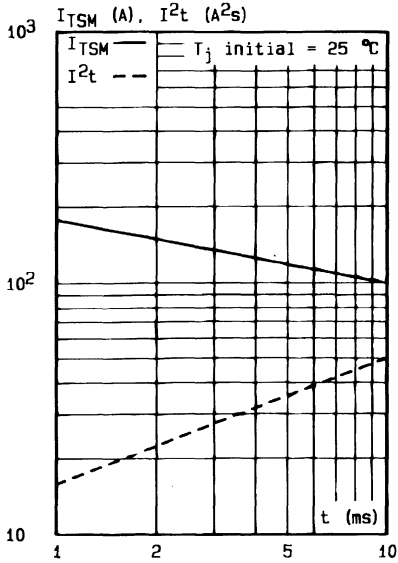

Fig. 7 - Non repetitive surge peak on-state current for a sinusoidal pulse with width :  $t \leq 10$  ms, and corresponding value of  $I^2t$ .

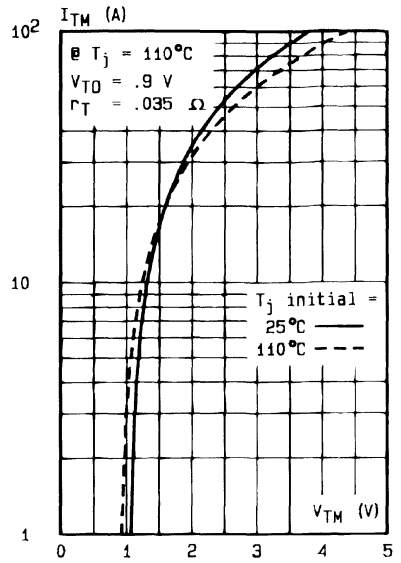
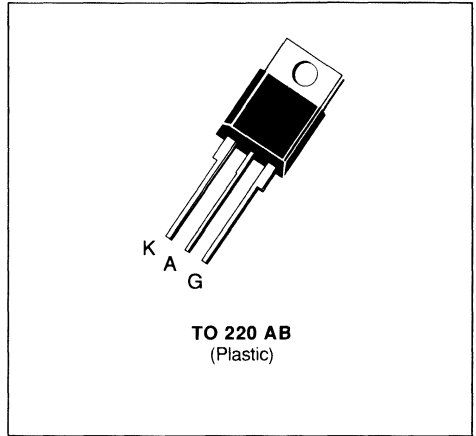

Fig. 8 - On-state characteristics (maximum values).

**THYRISTORS**

- GLASS PASSIVATED CHIP
- POSSIBILITY OF MOUNTING ON PRINTED CIRCUIT
- AVAILABLE IN NON-INSULATED VERSION → TYN SERIES OR IN INSULATED VERSION → TXN SERIES (INSULATING VOLTAGE 2500 V<sub>RMS</sub>)
- UL RECOGNIZED FOR TXN SERIES (E81734)

**DESCRIPTION**

SCR's designed for motor control, heating controls, power supplies...

**ABSOLUTE RATINGS** (limiting values)

Symbol	Parameter	Value	Unit
$I_{T(RMS)}$	RMS on-state Current (1)	$T_c = 80\text{ }^\circ\text{C}$ 12	A
$I_{T(AV)}$	Mean on-state Current (1)	$T_c = 80\text{ }^\circ\text{C}$ 8	A
$I_{TSM}$	Non Repetitive Surge Peak on-state Current ( $T_j$ initial = $25\text{ }^\circ\text{C}$ ) (2)	$t = 8.3\text{ ms}$	125
		$t = 10\text{ ms}$	120
$I^2t$	$I^2t$ Value for Fusing	$t = 10\text{ ms}$	72
$di/dt$	Critical Rate of Rise of on-state Current (3)	100	A/ $\mu\text{s}$
$T_{stg}$ $T_j$	Storage and Operating Junction Temperature Range	- 40 to 125 - 40 to 125	$^\circ\text{C}$ $^\circ\text{C}$

Symbol	Parameter	TXN/TYN							Unit
		0512	112	212	412	612	812	1012	
$V_{DRM}$ $V_{RRM}$	Repetitive Peak off-state Voltage (4)	50	100	200	400	600	800	1000	V

(1) Single phase circuit,  $180^\circ$  conduction angle.

(2) Half sine wave.

(3)  $I_G = 150\text{ mA}$   $di/dt = 1\text{ A}/\mu\text{s}$ .

(4)  $T_j = 125\text{ }^\circ\text{C}$ .

**THERMAL RESISTANCES**

Symbol	Parameter	Value	Unit
$R_{th(j-c)}$	Junction-case for D.C.	3.8	$^\circ\text{C}/\text{W}$
$R_{th(j-a)}$	Junction-ambient	60	$^\circ\text{C}/\text{W}$

**GATE CHARACTERISTICS** (maximum values)

 $P_{GM} = 20 \text{ W}$  ( $t_p = 20 \mu\text{s}$ )

 $I_{FGM} = 2 \text{ A}$  ( $t_p = 20 \mu\text{s}$ )

 $V_{RGM} = 5 \text{ V}$ 
 $P_{G(AV)} = 0.5 \text{ W}$ 
 $V_{FGM} = 15 \text{ V}$  ( $t_p = 20 \mu\text{s}$ )

**ELECTRICAL CHARACTERISTICS**

Symbol	Test Conditions			Min.	Typ.	Max.	Unit
$I_{GT}$	$T_j = 25 \text{ }^\circ\text{C}$ Pulse Duration $> 20 \mu\text{s}$	$V_D = 12 \text{ V}$	$R_L = 33 \Omega$			15	mA
$V_{GT}$	$T_j = 25 \text{ }^\circ\text{C}$ Pulse Duration $> 20 \mu\text{s}$	$V_D = 12 \text{ V}$	$R_L = 33 \Omega$			1.5	V
$V_{GD}$	$T_j = 125 \text{ }^\circ\text{C}$	$V_D = V_{DRM}$	$R_L = 3.3 \text{ k}\Omega$	0.2			V
$I_H$	$T_j = 25 \text{ }^\circ\text{C}$	$I_T = 100 \text{ mA}$	Gate Open			30	mA
$I_L$	$T_j = 25 \text{ }^\circ\text{C}$ Pulse Duration $> 20 \mu\text{s}$	$V_D = 12 \text{ V}$	$I_G = 30 \text{ mA}$		50		mA
$V_{TM}$	$T_j = 25 \text{ }^\circ\text{C}$	$I_{TM} = 24 \text{ A}$	$t_p = 10 \text{ ms}$			1.6	V
$I_{DRM}$	$T_j = 25 \text{ }^\circ\text{C}$	$V_{DRM}$ Specified				0.01	mA
	$T_j = 125 \text{ }^\circ\text{C}$	$V_{DRM} \leq 800 \text{ V}$				2	
		$V_{DRM} = 1000 \text{ V}$				3	
$I_{RRM}$	$T_j = 25 \text{ }^\circ\text{C}$	$V_{RRM}$ Specified				0.01	mA
	$T_j = 125 \text{ }^\circ\text{C}$	$V_{RRM} \leq 800 \text{ V}$				2	
		$V_{RRM} = 1000 \text{ V}$				3	
$t_{gt}$	$T_j = 25 \text{ }^\circ\text{C}$ $I_G = 40 \text{ mA}$	$V_D = V_{DRM}$ $di_G/dt = 0.45 \text{ A}/\mu\text{s}$	$I_T = 24 \text{ A}$		2		$\mu\text{s}$
$t_q$	$T_j = 125 \text{ }^\circ\text{C}$ $V_D = 67 \% V_{DRM}$ Gate Open	$I_T = 24 \text{ A}$ $di/dt = 30 \text{ A}/\mu\text{s}$	$V_R = 25 \text{ V}$ $dv/dt = 50 \text{ V}/\mu\text{s}$		70		$\mu\text{s}$
$dv/dt^*$	$T_j = 125 \text{ }^\circ\text{C}$ Linear Slope up to $V_D = 67 \% V_{DRM}$	Gate Open		200			V/ $\mu\text{s}$

\* For higher guaranteed values, please consult us.

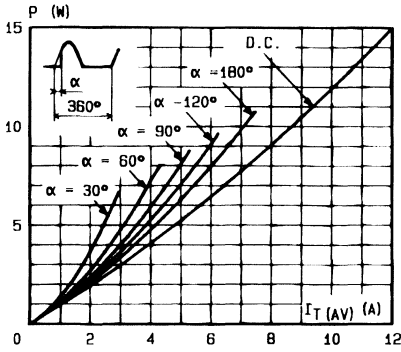

Fig. 1 - Maximum mean power dissipation versus mean on-state current.

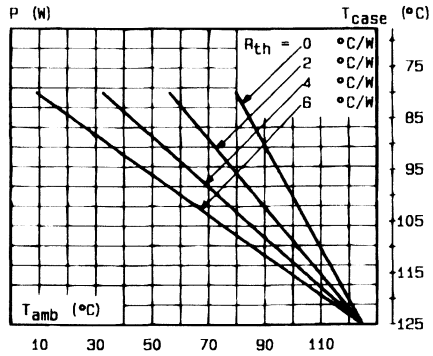

Fig. 2 - Correlation between maximum mean power dissipation and maximum allowable temperatures ( $T_{amb}$  and  $T_{case}$ ) for different thermal resistances heatsink + contact.

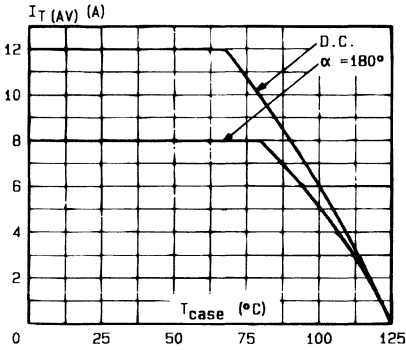

Fig. 3 - Mean on-state current versus case temperature.

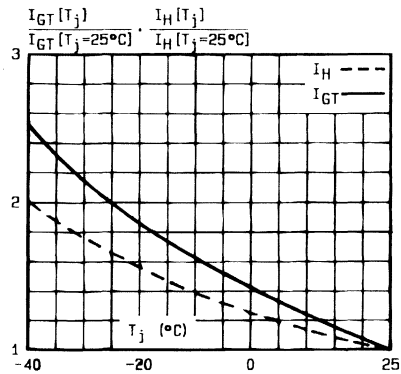

Fig. 5 - Relative variation of gate trigger current and holding current versus junction temperature.

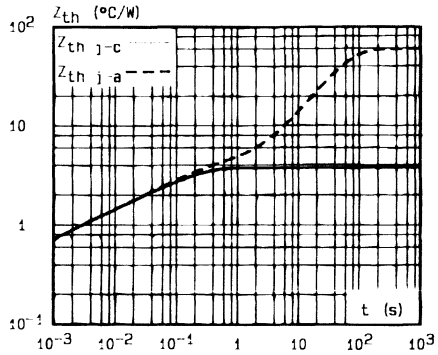

Fig. 4 - Thermal transient impedance junction to case and junction to ambient versus pulse duration.

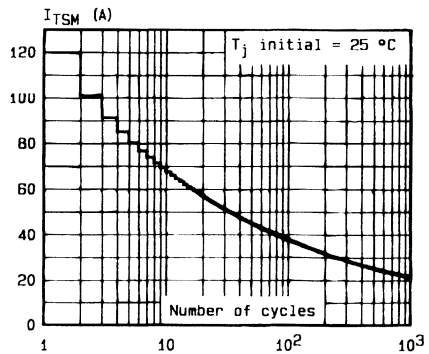

Fig. 6 - Non repetitive surge peak on-state current versus number of cycles.

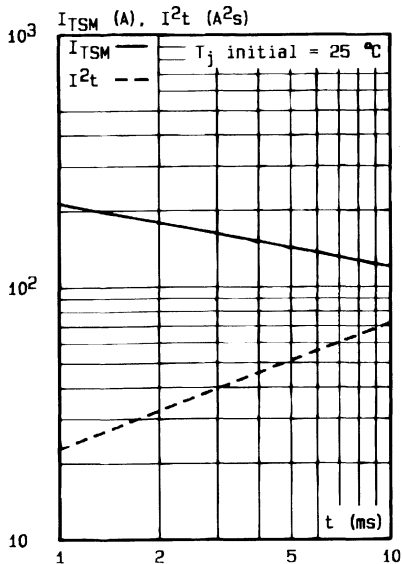

Fig.7 - Non repetitive surge peak on-state current for a sinusoidal pulse with width :  $t \leq 10$  ms, and corresponding value of  $I^2t$ .

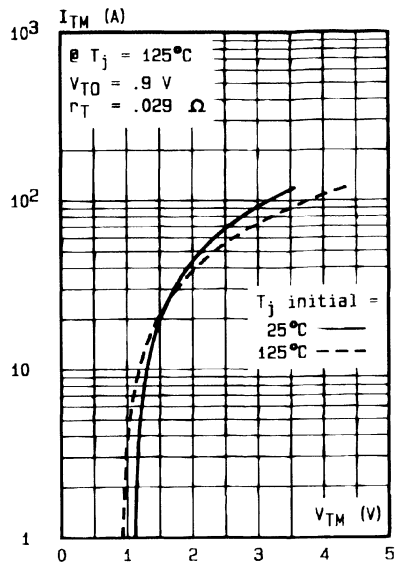
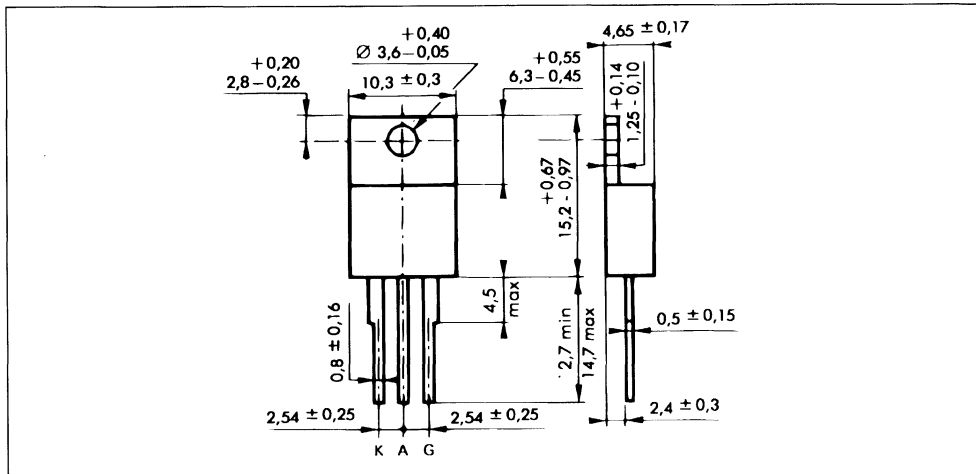

Fig.8 - On-state characteristics (maximum values).

**PACKAGE MECHANICAL DATA : TO 220 AB Plastic**



Cooling method : by conduction (method C)  
 Marking : type number  
 Weight : 2 g



**THYRISTORS**

- GLASS PASSIVATED CHIP
- POSSIBILITY OF MOUNTING ON PRINTED CIRCUIT

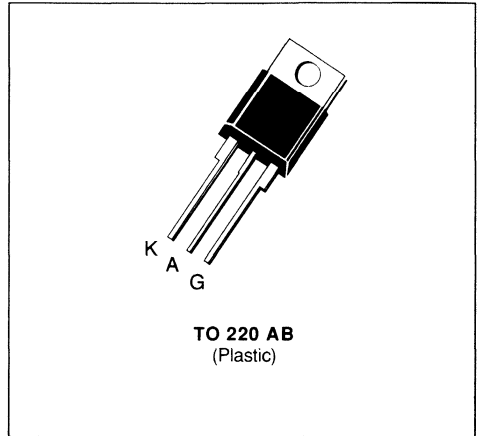
**DESCRIPTION**

SCR's designed for motor control, heating controls, power supplies...

**ABSOLUTE RATINGS (limiting values)**

Symbol	Parameter		Value	Unit
$I_{T(RMS)}$	RMS on-state Current (1)	$T_c = 90\text{ }^\circ\text{C}$	16	A
$I_{T(AV)}$	Mean on-state Current (1)	$T_c = 90\text{ }^\circ\text{C}$	10	A
$I_{TSM}$	Non Repetitive Surge Peak on-state Current ( $T_j$ initial = $25\text{ }^\circ\text{C}$ ) (2)	$t = 8.3\text{ ms}$	167	A
		$t = 10\text{ ms}$	160	
$I^2t$	$I^2t$ Value for Fusing	$t = 10\text{ ms}$	128	A <sup>2</sup> s
$di/dt$	Critical Rate of Rise of on-state Current (3)		100	A/ $\mu$ s
$T_{stg}$ $T_j$	Storage and Operating Junction Temperature Range		- 40 to 125	$^\circ\text{C}$
			- 40 to 125	$^\circ\text{C}$

Symbol	Parameter	TYN						Unit
		0516	116	216	416	616	816	
$V_{DRM}$ $V_{RRM}$	Repetitive Peak off-state Voltage (4)	50	100	200	400	600	800	V

(1) Single phase circuit,  $180^\circ$  conduction angle.

(2) Half sine wave.

(3)  $I_G = 250\text{ mA}$   $di_G/dt = 1\text{ A}/\mu\text{s}$ .

(4)  $T_j = 125\text{ }^\circ\text{C}$ .

**THERMAL RESISTANCES**

Symbol	Parameter	Value	Unit
$R_{th(j-c)}$	Junction-case for D.C.	2.5	$^\circ\text{C}/\text{W}$
$R_{th(j-a)}$	Junction-ambient	60	$^\circ\text{C}/\text{W}$

**GATE CHARACTERISTICS** (maximum values)

$P_{GM} = 20 \text{ W}$  ( $t_p = 20 \mu\text{s}$ )       $I_{FGM} = 2 \text{ A}$  ( $t_p = 20 \mu\text{s}$ )       $V_{RGM} = 5 \text{ V}$   
 $P_{G(AV)} = 0.5 \text{ W}$        $V_{FGM} = 15 \text{ V}$  ( $t_p = 20 \mu\text{s}$ )

**ELECTRICAL CHARACTERISTICS**

Symbol	Test Conditions			Min.	Typ.	Max.	Unit
$I_{GT}$	$T_j = 25 \text{ }^\circ\text{C}$ Pulse Duration > 20 $\mu\text{s}$	$V_D = 12 \text{ V}$	$R_L = 33 \text{ } \Omega$			25	mA
$V_{GT}$	$T_j = 25 \text{ }^\circ\text{C}$ Pulse Duration > 20 $\mu\text{s}$	$V_D = 12 \text{ V}$	$R_L = 33 \text{ } \Omega$			1.5	V
$V_{GD}$	$T_j = 125 \text{ }^\circ\text{C}$	$V_D = V_{DRM}$	$R_L = 3.3 \text{ k}\Omega$	0.2			V
$I_H$	$T_j = 25 \text{ }^\circ\text{C}$	$I_T = 100 \text{ mA}$	Gate Open			40	mA
$I_L$	$T_j = 25 \text{ }^\circ\text{C}$ Pulse Duration > 20 $\mu\text{s}$	$V_D = 12 \text{ V}$	$I_G = 50 \text{ mA}$		70		mA
$V_{TM}$	$T_j = 25 \text{ }^\circ\text{C}$	$I_{TM} = 32 \text{ A}$	$t_p = 10 \text{ ms}$			1.6	V
$I_{DRM}$	$V_{DRM}$ Specified			$T_j = 25 \text{ }^\circ\text{C}$		0.01	mA
				$T_j = 125 \text{ }^\circ\text{C}$		2	
$I_{RRM}$	$V_{RRM}$ Specified			$T_j = 25 \text{ }^\circ\text{C}$		0.01	mA
				$T_j = 125 \text{ }^\circ\text{C}$		2	
$t_{gt}$	$T_j = 25 \text{ }^\circ\text{C}$ $I_G = 80 \text{ mA}$	$V_D = V_{DRM}$ $di_G/dt = 0.85 \text{ A}/\mu\text{s}$	$I_T = 32 \text{ A}$		2		$\mu\text{s}$
$t_q$	$T_j = 125 \text{ }^\circ\text{C}$ $V_D = 67 \% V_{DRM}$ Gate Open	$I_T = 32 \text{ A}$ $di/dt = 30 \text{ A}/\mu\text{s}$	$V_R = 25 \text{ V}$ $dv/dt = 50 \text{ V}/\mu\text{s}$		70		$\mu\text{s}$
$dv/dt^*$	$T_j = 125 \text{ }^\circ\text{C}$ Linear Slope up to $V_D$	Gate Open $= 67 \% V_{DRM}$		500			V/ $\mu\text{s}$

\* For higher guaranteed values, please consult us.

**PACKAGE MECHANICAL DATA : TO 220 AB Plastic**

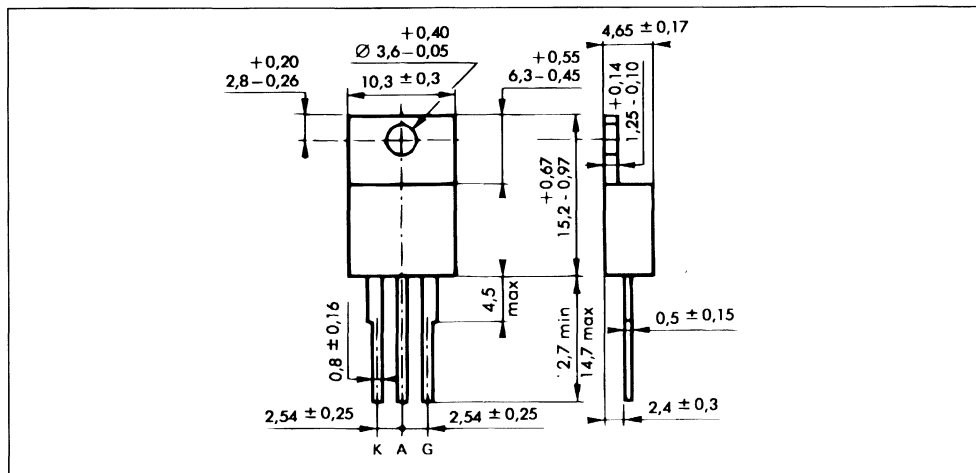

Cooling method : by conduction (method C)

Marking : type number

Weight : 2 g

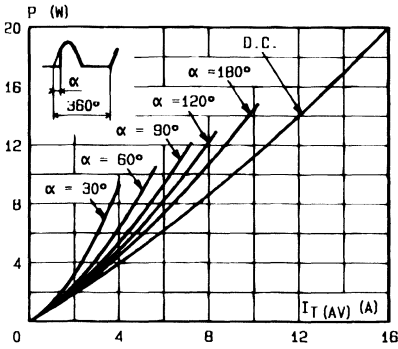

Fig.1 - Maximum mean power dissipation versus mean on-state current.

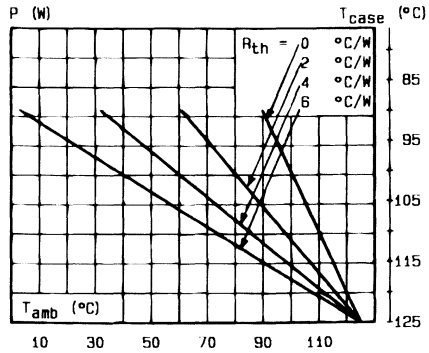

Fig.2 - Correlation between maximum mean power dissipation and maximum allowable temperatures ( $T_{amb}$  and  $T_{case}$ ) for different thermal resistances heatsink + contact.

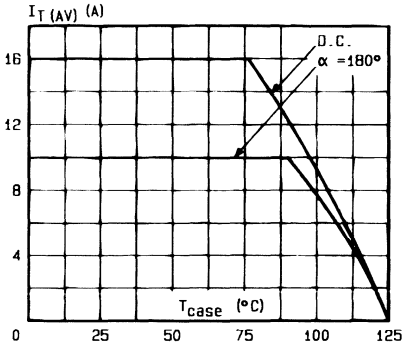

Fig.3 - Mean on-state current versus case temperature.

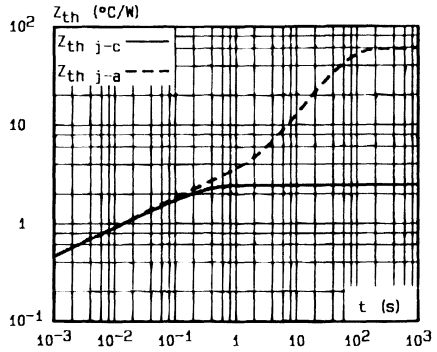

Fig.4 - Thermal transient impedance junction to case and junction to ambient versus pulse duration.

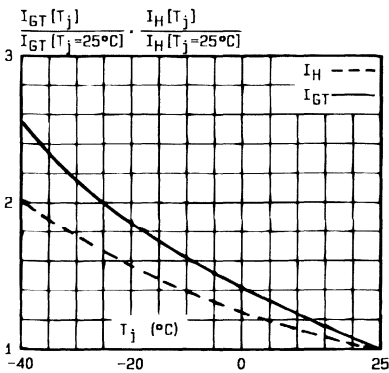

Fig.5 - Relative variation of gate trigger current and holding current versus junction temperature.

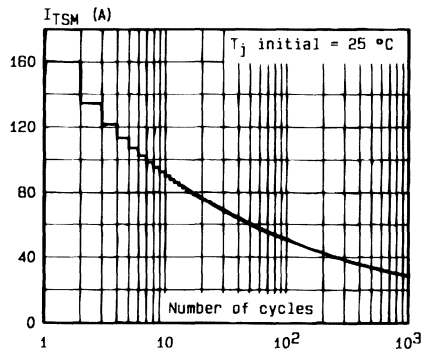

Fig.6 - Non repetitive surge peak on-state current versus number of cycles.

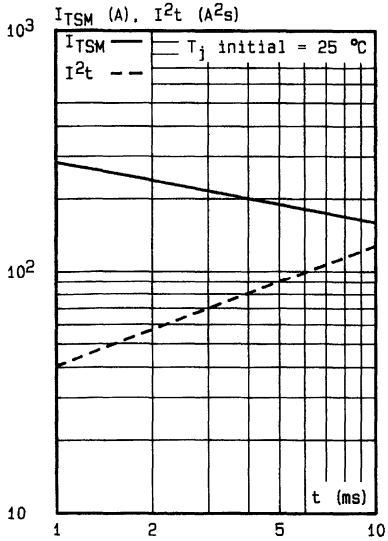

Fig.7 - Non repetitive surge peak on-state current for a sinusoidal pulse with width :  $t \leq 10$  ms, and corresponding value of  $I^2t$ .

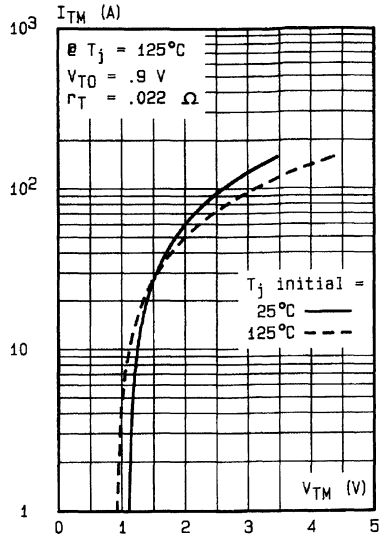
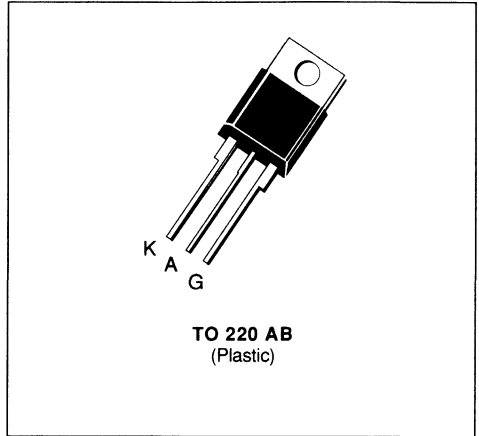

Fig.8 - On-state characteristics (maximum values).

**THYRISTORS**

- GLASS PASSIVATED CHIP
- POSSIBILITY OF MOUNTING ON PRINTED CIRCUIT

**DESCRIPTION**

SCR's designed for motor control, heating controls, power supplies...

**ABSOLUTE RATINGS** (limiting values)

Symbol	Parameter		Value	Unit
$I_{T(RMS)}$	RMS on-state Current (1)	$T_c = 85\text{ }^\circ\text{C}$	20	A
$I_{T(AV)}$	Mean on-state Current (1)	$T_c = 85\text{ }^\circ\text{C}$	13	A
$I_{TSM}$	Non Repetitive Surge Peak on-state Current ( $T_j$ initial = $25\text{ }^\circ\text{C}$ ) (2)	$t = 8.3\text{ ms}$	210	A
		$t = 10\text{ ms}$	200	
$I^2t$	$I^2t$ Value for Fusing	$t = 10\text{ ms}$	200	$\text{A}^2\text{s}$
$di/dt$	Critical Rate of Rise of on-state Current (3)		100	$\text{A}/\mu\text{s}$
$T_{stg}$ $T_j$	Storage and Operating Junction Temperature Range		- 40 to 125 - 40 to 125	$^\circ\text{C}$ $^\circ\text{C}$

Symbol	Parameter	TYN						Unit
		682	683	685	688	690	692	
$V_{DRM}$ $V_{RRM}$	Repetitive Peak off-state Voltage (4)	50	100	200	400	600	800	V

(1) Single phase circuit,  $180^\circ$  conduction angle.

(2) Half sine wave.

(3)  $I_G = 250\text{ mA}$   $di/dt = 1\text{ A}/\mu\text{s}$ .

(4)  $T_j = 125\text{ }^\circ\text{C}$ .

**THERMAL RESISTANCES**

Symbol	Parameter	Value	Unit
$R_{th(j-c)}$	Junction-case for D.C.	2.5	$^\circ\text{C}/\text{W}$
$R_{th(j-a)}$	Junction-ambient	60	$^\circ\text{C}/\text{W}$

**GATE CHARACTERISTICS** (maximum values)

$P_{GM} = 20 \text{ W}$  ( $t_p = 20 \mu\text{s}$ )       $I_{FGM} = 2 \text{ A}$  ( $t_p = 20 \mu\text{s}$ )       $V_{RGM} = 5 \text{ V}$   
 $P_{G(AV)} = 0.5 \text{ W}$        $V_{FGM} = 15 \text{ V}$  ( $t_p = 20 \mu\text{s}$ )

**ELECTRICAL CHARACTERISTICS**

Symbol	Test Conditions			Min.	Typ.	Max.	Unit
$I_{GT}$	$T_j = 25 \text{ }^\circ\text{C}$ Pulse Duration > 20 $\mu\text{s}$	$V_D = 12 \text{ V}$	$R_L = 33 \text{ }\Omega$			25	mA
$V_{GT}$	$T_j = 25 \text{ }^\circ\text{C}$ Pulse Duration > 20 $\mu\text{s}$	$V_D = 12 \text{ V}$	$R_L = 33 \text{ }\Omega$			1.5	V
$V_{GD}$	$T_j = 125 \text{ }^\circ\text{C}$	$V_D = V_{DRM}$	$R_L = 3.3 \text{ k}\Omega$	0.2			V
$I_H$	$T_j = 25 \text{ }^\circ\text{C}$	$I_T = 100 \text{ mA}$	Gate Open			40	mA
$I_L$	$T_j = 25 \text{ }^\circ\text{C}$ Pulse Duration > 20 $\mu\text{s}$	$V_D = 12 \text{ V}$	$I_G = 50 \text{ mA}$		70		mA
$V_{TM}$	$T_j = 25 \text{ }^\circ\text{C}$	$I_{TM} = 50 \text{ A}$	$t_p = 10 \text{ ms}$			1.4	V
$I_{DRM}$	$V_{DRM}$ Specified			$T_j = 25 \text{ }^\circ\text{C}$		0.01	mA
				$T_j = 125 \text{ }^\circ\text{C}$		2	
$I_{RRM}$	$V_{RRM}$ Specified			$T_j = 25 \text{ }^\circ\text{C}$		0.01	mA
				$T_j = 125 \text{ }^\circ\text{C}$		2	
$t_{gt}$	$T_j = 25 \text{ }^\circ\text{C}$ $I_G = 80 \text{ mA}$	$V_D = V_{DRM}$ $di_G/dt = 0.85 \text{ A}/\mu\text{s}$	$I_T = 50 \text{ A}$		2		$\mu\text{s}$
$t_q$	$T_j = 125 \text{ }^\circ\text{C}$ $V_D = 67 \% V_{DRM}$ Gate Open	$I_T = 50 \text{ A}$ $di/dt = 30 \text{ A}/\mu\text{s}$	$V_R = 25 \text{ V}$ $dv/dt = 50 \text{ V}/\mu\text{s}$		70		$\mu\text{s}$
$dv/dt^*$	$T_j = 125 \text{ }^\circ\text{C}$ Linear Slope up to $V_D = 67 \% V_{DRM}$	Gate Open		500			V/ $\mu\text{s}$

\* For higher guaranteed values, please consult us.

**PACKAGE MECHANICAL DATA : TO 220 AB Plastic**

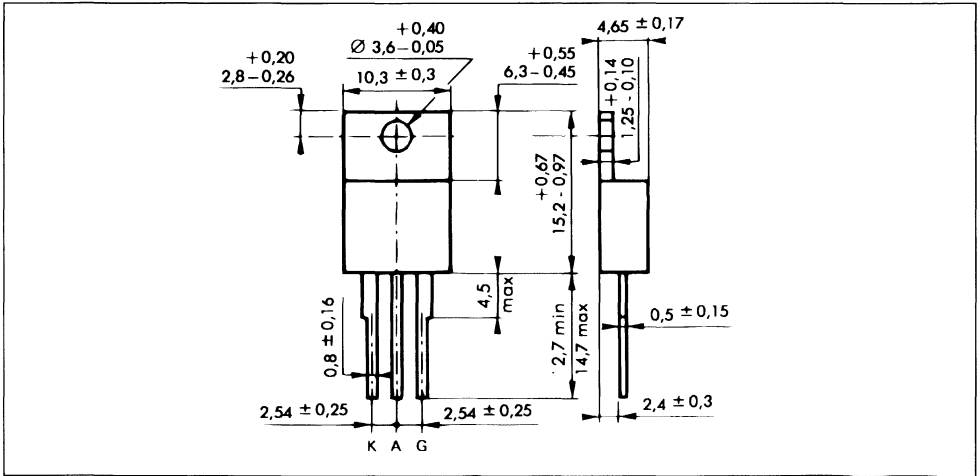

Cooling method : by conduction (method C)  
 Marking : type number  
 Weight : 2 g

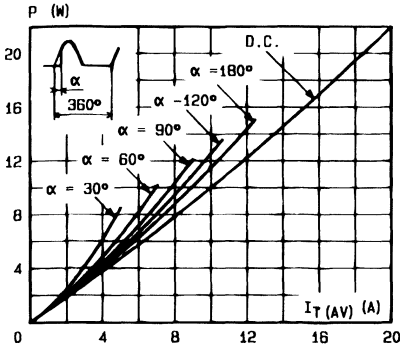

Fig.1 - Maximum mean power dissipation versus mean on-state current.

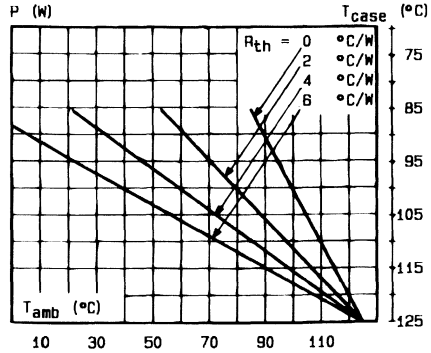

Fig.2 - Correlation between maximum mean power dissipation and maximum allowable temperatures ( $T_{amb}$  and  $T_{case}$ ) for different thermal resistances heatsink + contact.

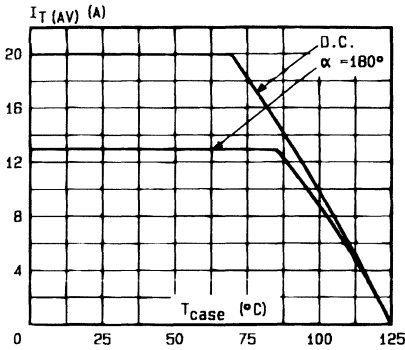

Fig.3 - Mean on-state current versus case temperature.

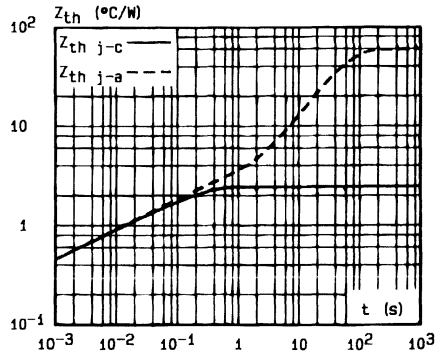

Fig.4 - Thermal transient impedance junction to case and junction to ambient versus pulse duration.

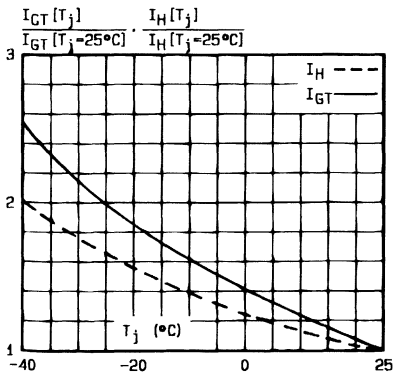

Fig.5 - Relative variation of gate trigger current and holding current versus junction temperature.

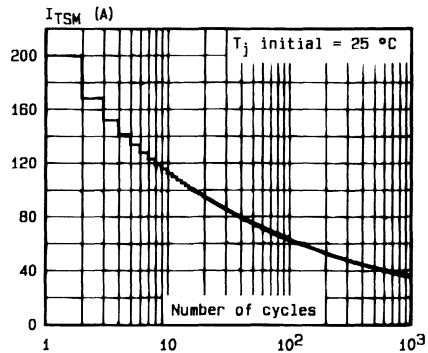

Fig.6 - Non repetitive surge peak on-state current versus number of cycles.

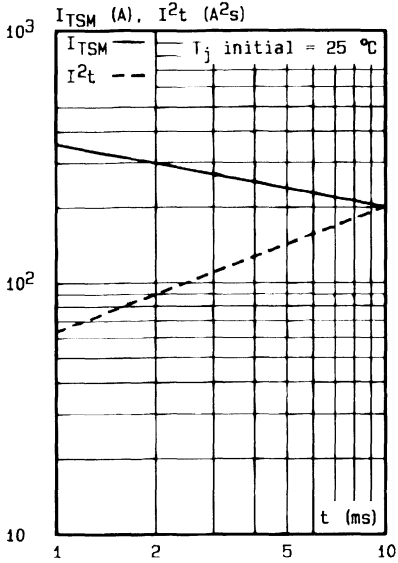

Fig. A - Non repetitive surge peak on-state current for a sinusoidal pulse with width :  $t \leq 10$  ms, and corresponding value of  $I^2t$ .

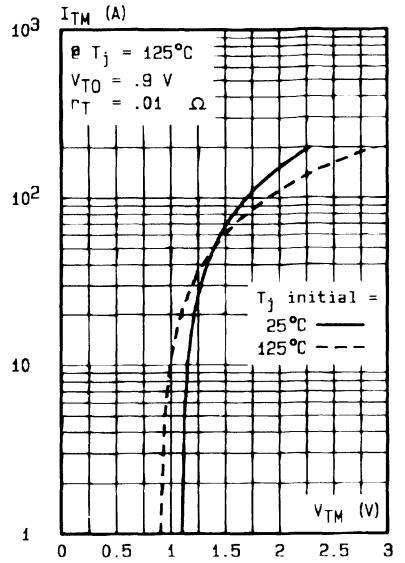

Fig. B - Un-state characteristics (maximum values).





**THYRISTORS**

- GLASS PASSIVATED CHIP
- POSSIBILITY OF MOUNTING ON PRINTED CIRCUIT

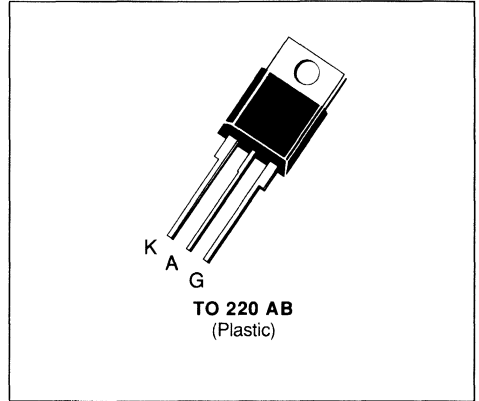

**DESCRIPTION**

SCR 's designed for motor control, heating controls, power supplies...

**ABSOLUTE RATINGS** (limiting values)

Symbol	Parameter		TYN	TYN	Unit
			225 to 825	1025 - 1225	
$I_{T(RMS)}$	RMS on-state Current (1)	$T_c = 90\text{ }^\circ\text{C}$	25		A
$I_{T(AV)}$	Mean on-state Current (1)	$T_c = 90\text{ }^\circ\text{C}$	16		A
$I_{TSM}$	Non Repetitive Surge Peak on-state Current ( $T_j$ initial = $25\text{ }^\circ\text{C}$ ) (2)	$t = 8.3\text{ ms}$	315	260	A
		$t = 10\text{ ms}$	300	250	
$I^2t$	$I^2t$ Value for Fusing	$t = 10\text{ ms}$	450	310	$\text{A}^2\text{s}$
$di/dt$	Critical Rate of Rise of on-state Current (3)		100		$\text{A}/\mu\text{s}$
$T_{stg}$ $T_j$	Storage and Operating Junction Temperature Range		- 40 to 125		$^\circ\text{C}$ $^\circ\text{C}$

Symbol	Parameter	TYN						Unit
		225	425	625	825	1025	1225	
$V_{DRM}$ $V_{RRM}$	Repetitive Peak off-state Voltage (4)	200	400	600	800	1000	1200	V

(1) Single phase circuit,  $180^\circ$  conduction angle.

(2) Half sine wave.

(3)  $I_G = 400\text{ mA}$   $di/dt = 1\text{ A}/\mu\text{s}$ .

(4)  $T_j = 125\text{ }^\circ\text{C}$ .

**THERMAL RESISTANCES**

Symbol	Parameter	Value	Unit
$R_{th(j-c)}$	Junction-case for D.C.	1.5	$^\circ\text{C}/\text{W}$
$R_{th(j-a)}$	Junction-ambient	60	$^\circ\text{C}/\text{W}$

**GATE CHARACTERISTICS** (maximum values)

$P_{GM} = 20 \text{ W}$  ( $t_p = 20 \mu\text{s}$ )

$I_{FGM} = 2 \text{ A}$  ( $t_p = 20 \mu\text{s}$ )

$V_{RGM} = 5 \text{ V}$

$P_{G(AV)} = 0.5 \text{ W}$

$V_{FGM} = 15 \text{ V}$  ( $t_p = 20 \mu\text{s}$ )

**ELECTRICAL CHARACTERISTICS**

Symbol	Test Conditions			Min.	Typ.	Max.	Unit
$I_{GT}$	$T_j = 25 \text{ }^\circ\text{C}$ Pulse Duration > 20 $\mu\text{s}$	$V_D = 12 \text{ V}$	$R_L = 33 \text{ } \Omega$			40	mA
$V_{GT}$	$T_j = 25 \text{ }^\circ\text{C}$ Pulse Duration > 20 $\mu\text{s}$	$V_D = 12 \text{ V}$	$R_L = 33 \text{ } \Omega$			1.5	V
$V_{GD}$	$T_j = 125 \text{ }^\circ\text{C}$	$V_D = V_{DRM}$	$R_L = 3.3 \text{ k}\Omega$	0.2			V
$I_H$	$T_j = 25 \text{ }^\circ\text{C}$	$I_T = 100 \text{ mA}$	Gate Open			50	mA
$I_L$	$T_j = 25 \text{ }^\circ\text{C}$ Pulse Duration > 20 $\mu\text{s}$	$V_D = 12 \text{ V}$	$I_G = 80 \text{ mA}$		80		mA
$V_{TM}$	$T_j = 25 \text{ }^\circ\text{C}$	$I_{TM} = 50 \text{ A}$	$t_p = 10 \text{ ms}$			1.6	V
$I_{DRM}$	$T_j = 125 \text{ }^\circ\text{C}$	$V_{DRM}$ Specified	TYN 225 → 825	0.2	2.5		mA
			TYN 1025 - 1225	0.5	5		
$I_{RRM}$	$T_j = 125 \text{ }^\circ\text{C}$	$V_{RRM}$ Specified	TYN 225 → 825	0.2	2.5		mA
			TYN 1025 - 1225	0.5	5		
$t_{gt}$	$T_j = 25 \text{ }^\circ\text{C}$ $I_G = 80 \text{ mA}$	$V_D = V_{DRM}$ $di_G/dt = 0.85 \text{ A}/\mu\text{s}$	$I_T = 50 \text{ A}$		2		$\mu\text{s}$
$t_q$	$T_j = 125 \text{ }^\circ\text{C}$ $V_D = 67 \% V_{DRM}$ Gate Open	$I_T = 50 \text{ A}$ $di/dt = 30 \text{ A}/\mu\text{s}$	$V_R = 25 \text{ V}$ $dv/dt = 50 \text{ V}/\mu\text{s}$		70		$\mu\text{s}$
$dv/dt^*$	$T_j = 125 \text{ }^\circ\text{C}$ Linear Slope up to $V_D = 67 \% V_{DRM}$	Gate Open	TYN 225 → 825	500	750		V/ $\mu\text{s}$
			TYN 1025 - 1225	250	500		

\* For higher guaranteed values, please consult us.

**PACKAGE MECHANICAL DATA : TO 220 AB Plastic**

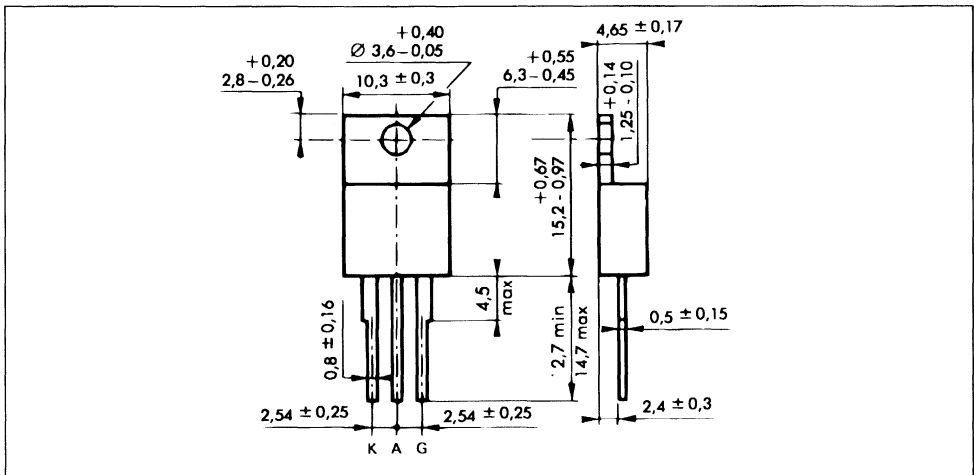

Cooling method : by conduction (method C)

Marking : type number

Weight : 2 g

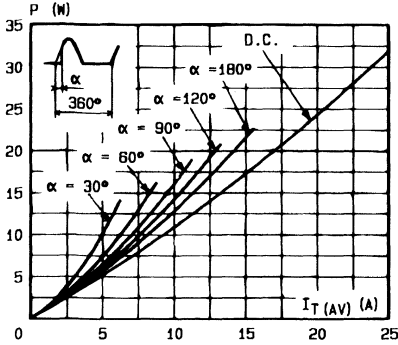

Fig. 1 - Maximum mean power dissipation versus mean on-state current.

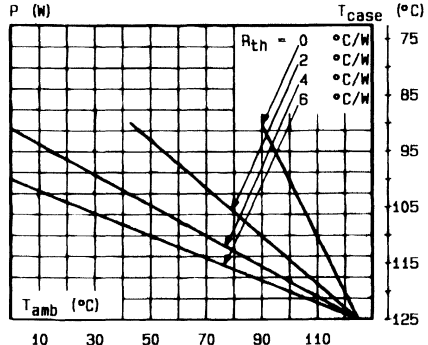

Fig. 2 - Correlation between maximum mean power dissipation and maximum allowable temperatures ( $T_{amb}$  and  $T_{case}$ ) for different thermal resistances heatsink + contact.

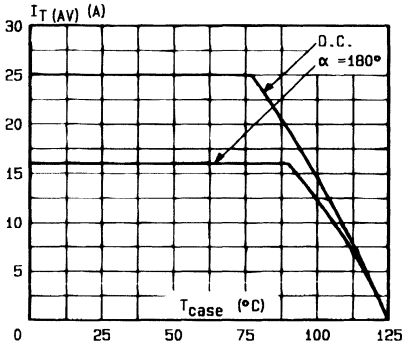

Fig. 3 - Mean on-state current versus case temperature.

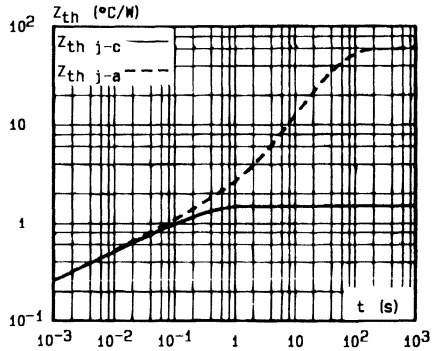

Fig. 4 - Thermal transient impedance junction to case and junction to ambient versus pulse duration.

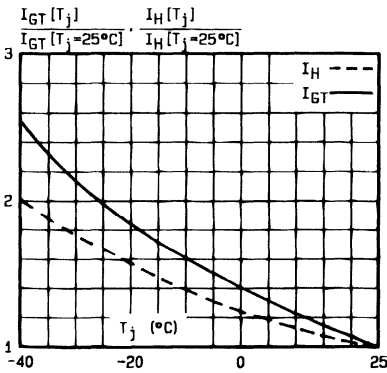

Fig. 5 - Relative variation of gate trigger current and holding current versus junction temperature.

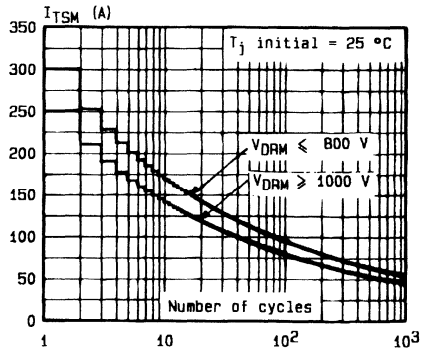

Fig. 6 - Non repetitive surge peak on-state current versus number of cycles.

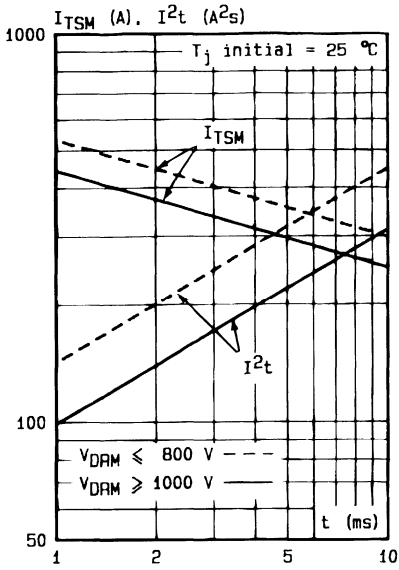

Fig. / - Non repetitive surge peak on-state current for a sinusoidal pulse with width :  $t \leq 10$  ms, and corresponding value of  $I^2t$ .

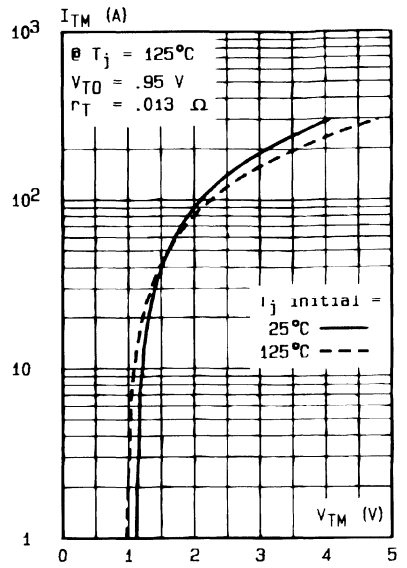
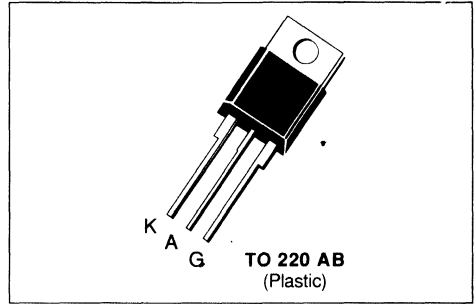

Fig.8 - On-state characteristics (maximum values).

## THYRISTORS FOR OVERVOLTAGE PROTECTION

- GLASS PASSIVATED CHIP
- HIGH STABILITY AND RELIABILITY
- HIGH SURGE CAPABILITY
- HIGH di/dt RATING

**DESCRIPTION**

SCR designed for overvoltage protection in crowbar circuits.

**ABSOLUTE RATINGS** (limiting values)

Symbol	Parameter	Value	Unit	
$I_{T(RMS)}$	RMS on-state Current (1)	$T_c = 75\text{ }^\circ\text{C}$ 12	A	
$I_{T(AV)}$	Mean on-state Current (1)	$T_c = 75\text{ }^\circ\text{C}$ 8	A	
$I_{TSM}$	Non Repetitive Surge Peak on-state Current ( $T_j$ initial = $25\text{ }^\circ\text{C}$ ) (2)	$t = 8.3\text{ ms}$	315	A
		$t = 10\text{ ms}$	300	
$I^2t$	$I^2t$ Value for Fusing	$t = 10\text{ ms}$ 450	$\text{A}^2\text{s}$	
$I_{TM}$	Non Repetitive Surge Peak on-state Current ( $T_j$ initial = $25\text{ }^\circ\text{C}$ ) (5)	$t = 1\text{ ms}$ 750	A	
di/dt	Critical Rate of Rise of on-state Current (3)	100	A/ $\mu\text{s}$	
$T_{stg}$ $T_j$	Storage and Operating Junction Temperature Range	- 40 to 125	$^\circ\text{C}$	
		- 40 to 125	$^\circ\text{C}$	

Symbol	Parameter	TYP212	TYP512	TYP1012	TYP2012	Unit
$V_{DRM}$ $V_{RRM}$	Repetitive Peak off-state Voltage (4)	25	50	100	200	V

(1) Single phase circuit,  $180^\circ$  conduction angle.

(2) Half sine wave.

(3)  $I_G = 300\text{ mA}$   $di_G/dt = 1\text{ A}/\mu\text{s}$ .

(4)  $T_j = 125\text{ }^\circ\text{C}$ .

(5) Exponential pulse wave form 10/1000.

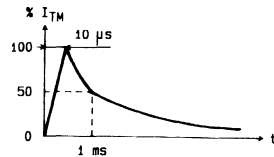

DB8THYPROTEC1

**THERMAL RESISTANCES**

Symbol	Parameter	Value	Unit
$R_{th(j-c)}$	Junction-case for D.C.	4.74	$^\circ\text{C}/\text{W}$
$R_{th(j-a)}$	Junction-ambient	60	$^\circ\text{C}/\text{W}$

**GATE CHARACTERISTICS** (maximum values)

$P_{GM} = 20 \text{ W}$  ( $t_p = 20 \mu\text{s}$ )       $I_{FGM} = 2 \text{ A}$  ( $t_p = 20 \mu\text{s}$ )       $V_{RGM} = 5 \text{ V}$   
 $P_{G(AV)} = 0.5 \text{ W}$        $V_{FGM} = 10 \text{ V}$  ( $t_p = 20 \mu\text{s}$ )

**ELECTRICAL CHARACTERISTICS**

Symbol	Test Conditions			Min.	Typ.	Max.	Unit
$I_{GT}$	$T_j = 25 \text{ }^\circ\text{C}$ Pulse Duration > 20 $\mu\text{s}$	$V_D = 12 \text{ V}$	$R_L = 33 \text{ } \Omega$			30	mA
$V_{GT}$	$T_j = 25 \text{ }^\circ\text{C}$ Pulse Duration > 20 $\mu\text{s}$	$V_D = 12 \text{ V}$	$R_L = 33 \text{ } \Omega$			1.5	V
$V_{GD}$	$T_j = 125 \text{ }^\circ\text{C}$	$V_D = V_{DRM}$	$R_L = 3.3 \text{ k}\Omega$	0.2			V
$I_H$	$T_j = 25 \text{ }^\circ\text{C}$	$I_T = 100 \text{ mA}$	Gate Open			50	mA
$I_L$	$T_j = 25 \text{ }^\circ\text{C}$ Pulse Duration > 20 $\mu\text{s}$	$V_D = 12 \text{ V}$	$I_G = 60 \text{ mA}$		60		mA
$V_{TM}$	$T_j = 25 \text{ }^\circ\text{C}$	$I_{TM} = 50 \text{ A}$	$t_p = 10 \text{ ms}$			1.5	V
	$T_j = 25 \text{ }^\circ\text{C}$ See note 5 on page 1/5.	$I_{TM} = 750 \text{ A}$	$t = 10 \text{ ms}$		6		
$I_{DRM}$	$V_{DRM}$ Specified			$T_j = 25 \text{ }^\circ\text{C}$		0.01	mA
				$T_j = 125 \text{ }^\circ\text{C}$		2	
$I_{RRM}$	$V_{RRM}$ Specified			$T_j = 25 \text{ }^\circ\text{C}$		0.01	mA
				$T_j = 125 \text{ }^\circ\text{C}$		2	
$t_{gt}$	$T_j = 25 \text{ }^\circ\text{C}$ $I_G = 200 \text{ mA}$	$V_D = V_{DRM}$ $di_G/dt = 1.5 \text{ A}/\mu\text{s}$	$I_T = 50 \text{ A}$		1		$\mu\text{s}$
$t_q$	$T_j = 125 \text{ }^\circ\text{C}$ $V_D = 67 \% V_{DRM}$ Gate Open	$I_T = 50 \text{ A}$ $di/dt = 30 \text{ A}/\mu\text{s}$	$V_R = 25 \text{ V}$ $dv/dt = 50 \text{ V}/\mu\text{s}$		100		$\mu\text{s}$
$dv/dt^*$	$T_j = 125 \text{ }^\circ\text{C}$ Linear Slope up to $V_D = 67 \% V_{DRM}$	Gate Open		200			V/ $\mu\text{s}$

\* For higher guaranteed values, please consult us.

**PACKAGE MECHANICAL DATA**

TO 220 AB Plastic

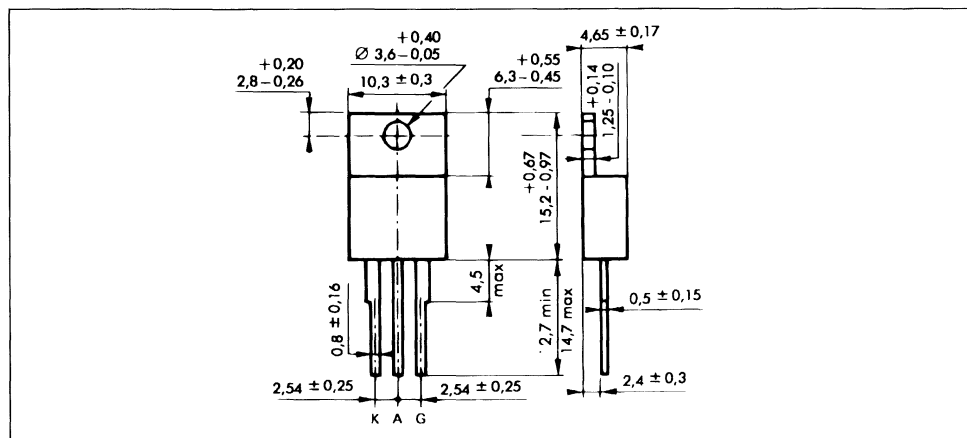

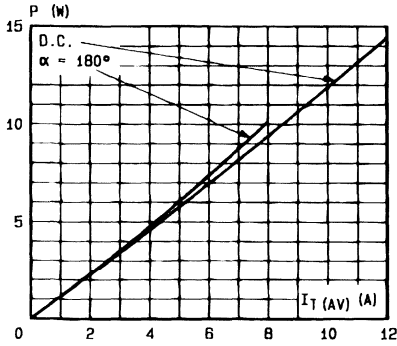

Fig. 1 - Maximum average power dissipation versus average on-state current (half sine wave 50 Hz and D.C).

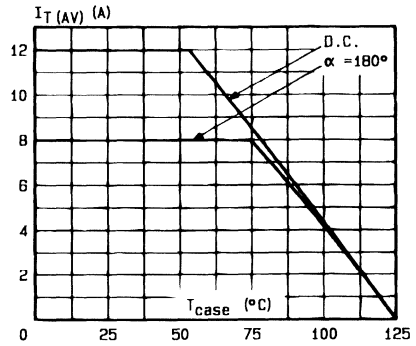

Fig. 2 - Maximum average on-state current versus case temperature (half sine wave 50 Hz and D.C).

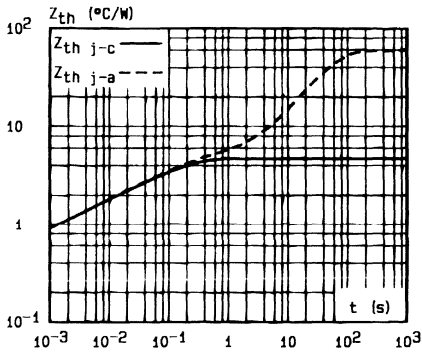

Fig. 3 - Thermal transient impedance junction to case and junction to ambient, versus pulse duration.

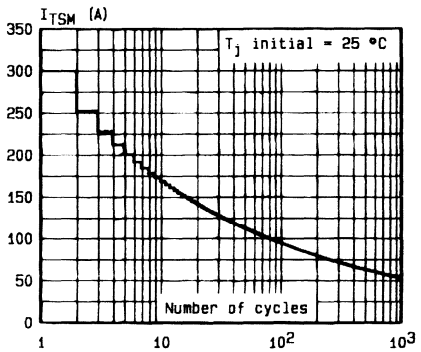

Fig. 4 - Non repetitive surge peak on-state current versus number of cycles.

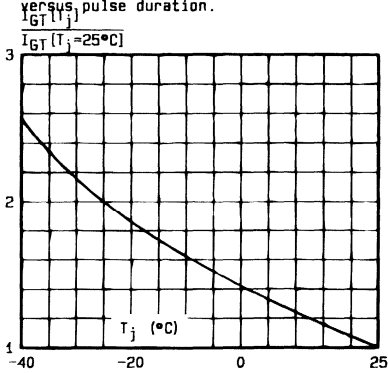

Fig. 5 - Relative variation of gate trigger current versus junction temperature.

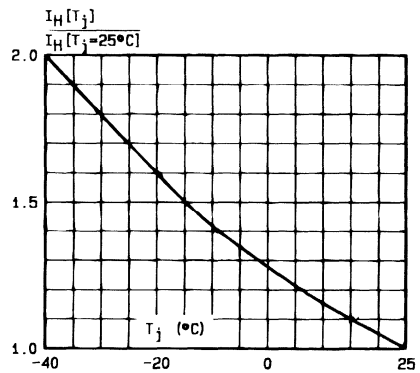

Fig. 6 - Relative variation of holding current versus junction temperature.

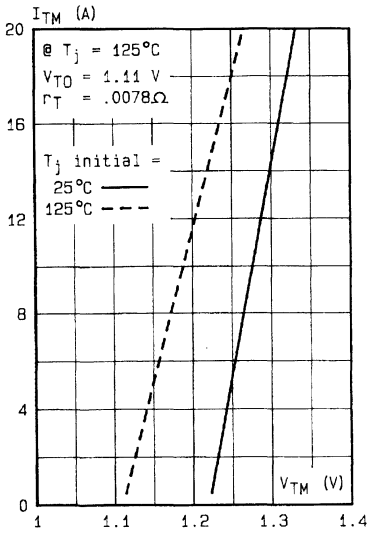

Fig.7 - On-state characteristics at low level (maximum values).

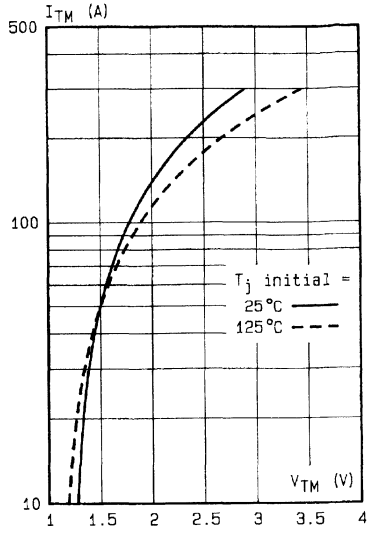

Fig.8 - On-state characteristics at high level (maximum values).

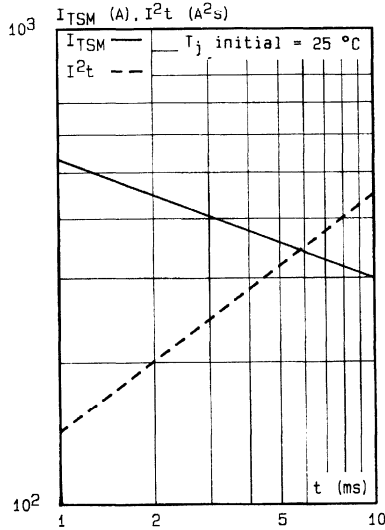

Fig.9 - Non repetitive surge peak on-state current for a sinusoidal pulse with width :  $t \leq 10$  ms, and corresponding value of  $I^2t$ .



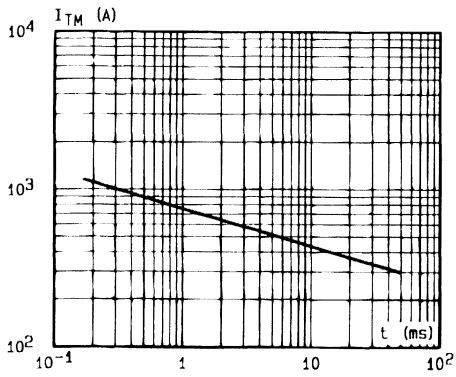

Fig.10 - Peak capacitor discharge current versus pulse width.

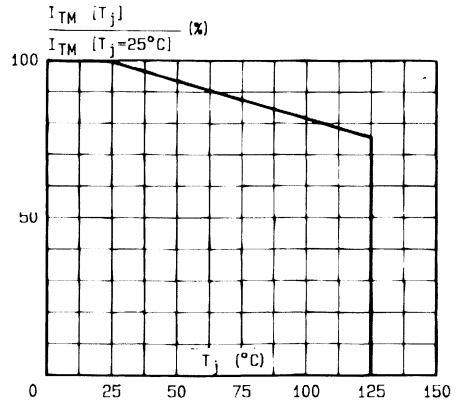
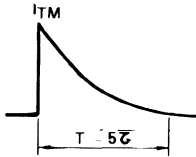
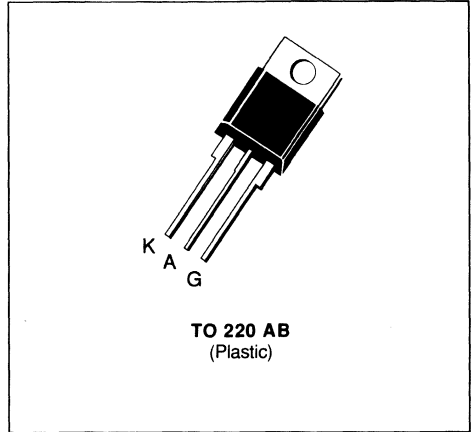

Fig.11 - Allowable peak capacitor discharge current versus initial junction temperature.



## SENSITIVE GATE THYRISTORS

- OPERATES DIRECTLY FROM LOW SIGNAL
- GLASS PASSIVATED CHIP
- POSSIBILITY OF MOUNTING ON PRINTED CIRCUIT



### ABSOLUTE RATINGS (limiting values)

Symbol	Parameter	Value	Unit	
$I_{T(RMS)}$	RMS on-state Current (1)	$T_c = 90\text{ }^\circ\text{C}$ 4	A	
$I_T(AV)$	Mean on-state Current (1)	$T_c = 90\text{ }^\circ\text{C}$ 2.5	A	
$I_{TSM}$	Non Repetitive Surge Peak on-state Current ( $T_j$ initial = $25\text{ }^\circ\text{C}$ ) (2)	$t = 8.3\text{ ms}$	52	A
		$t = 10\text{ ms}$	50	
$I^2t$	$I^2t$ Value for Fusing	$t = 10\text{ ms}$	12.5	$\text{A}^2\text{s}$
$di/dt$	Critical Rate of Rise of on-state Current (3)	100	$\text{A}/\mu\text{s}$	
$T_{stg}$ $T_j$	Storage and Operating Junction Temperature Range	- 40 to 110 - 40 to 110	$^\circ\text{C}$ $^\circ\text{C}$	

Symbol	Parameter	TYS406-... or TYS407-...						Unit
		05	1	2	4	6	8	
$V_{DRM}$ $V_{RRM}$	Repetitive Peak off-state Voltage (4)	50	100	200	400	600	800	V

(1) Single phase circuit,  $180^\circ$  conduction angle.

(2) Half sine wave.

(3)  $I_G = 5\text{ mA}$   $di_G/dt = 1\text{ A}/\mu\text{s}$ .

(4)  $T_j = 110\text{ }^\circ\text{C}$   $R_{\theta K} = 1\text{ K}/\Omega$ .

### THERMAL RESISTANCES

Symbol	Parameter	Value	Unit
$R_{th(j-c)}$	Junction-case for DC	5.5	$^\circ\text{C}/\text{W}$
$R_{th(j-a)}$	Junction-ambient	60	$^\circ\text{C}/\text{W}$

**GATE CHARACTERISTICS** (maximum values)

$P_{GM} = 20 \text{ W}$  ( $t_p = 20 \mu\text{s}$ )       $I_{FGM} = 2 \text{ A}$  ( $t_p = 20 \mu\text{s}$ )       $V_{RGM} = 5 \text{ V}$   
 $P_{G(AV)} = 0.5 \text{ W}$        $V_{FGM} = 15 \text{ V}$  ( $t_p = 20 \mu\text{s}$ )

**ELECTRICAL CHARACTERISTICS**

Symbol	Types	Test Conditions			Min.	Typ.	Max.	Unit
$I_{GT}$	TYS406	$T_j = 25 \text{ }^\circ\text{C}$	$V_D = 12 \text{ V}$	$R_L = 140 \text{ } \Omega$			0.2	mA
	TYS407	Pulse Duration > 20 $\mu\text{s}$					0.5	
$V_{GT}$		$T_j = 25 \text{ }^\circ\text{C}$	$V_D = 12 \text{ V}$	$R_L = 140 \text{ } \Omega$			1.5	V
$V_{GD}$		$T_j = 110 \text{ }^\circ\text{C}$	$V_D = V_{DRM}$	$R_L = 3.3 \text{ k}\Omega$	0.1			V
$I_H$		$T_j = 25 \text{ }^\circ\text{C}$	$I_T = 50 \text{ mA}$	$R_{GK} = 1 \text{ k}\Omega$			6	mA
$I_L$		$T_j = 25 \text{ }^\circ\text{C}$	$V_D = 12 \text{ V}$	$I_G = 10 \text{ mA}$		10		mA
$V_{TM}$		$T_j = 25 \text{ }^\circ\text{C}$	$I_{TM} = 8 \text{ A}$				1.6	V
$I_{DRM}$		$V_{DRM}$ specified $R_{GK} = 1 \text{ k}\Omega$		$T_j = 25 \text{ }^\circ\text{C}$			0.01	mA
				$T_j = 110 \text{ }^\circ\text{C}$			0.5	
$I_{RRM}$		$V_{RRM}$ specified $R_{GK} = 1 \text{ k}\Omega$		$T_j = 25 \text{ }^\circ\text{C}$			0.01	mA
				$T_j = 110 \text{ }^\circ\text{C}$			0.5	
$t_{gt}$		$T_j = 25 \text{ }^\circ\text{C}$	$V_D = V_{DRM}$	$I_T = 8 \text{ A}$		1.5		$\mu\text{s}$
$t_q$		$T_j = 110 \text{ }^\circ\text{C}$	$V_D = 67 \% V_{DRM}$	$I_T = 8 \text{ A}$		100		$\mu\text{s}$
$dv/dt^*$		$T_j = 110 \text{ }^\circ\text{C}$		$R_{GK} = 1 \text{ k}\Omega$		10		V/ $\mu\text{s}$
Linear Slope up to $V_D = 67 \% V_{DRM}$								

\* For higher guaranteed values, please consult us.

**PACKAGE MECHANICAL DATA**

TO 220 AB Plastic

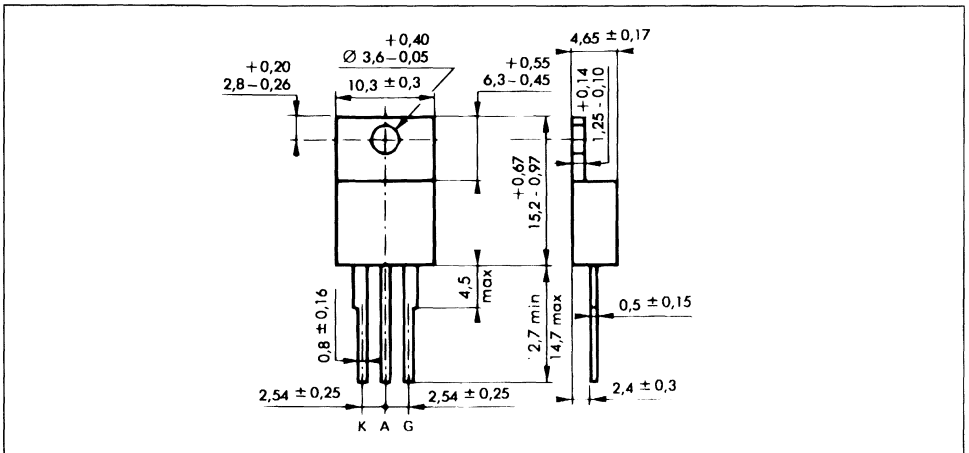

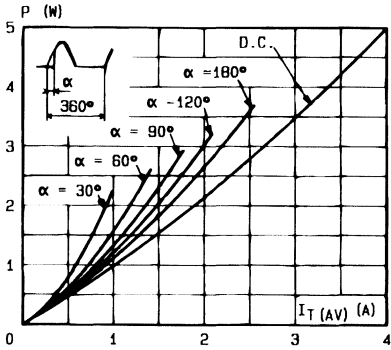

Fig. 1 - Maximum mean power dissipation versus mean on-state current.

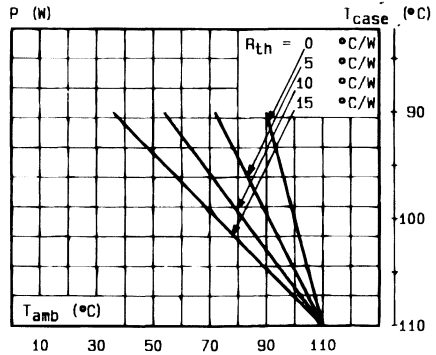

Fig. 2 - Correlation between maximum mean power dissipation and maximum allowable temperatures ( $T_{amb}$  and  $T_{case}$ ) for different thermal resistances heatsink + contact.

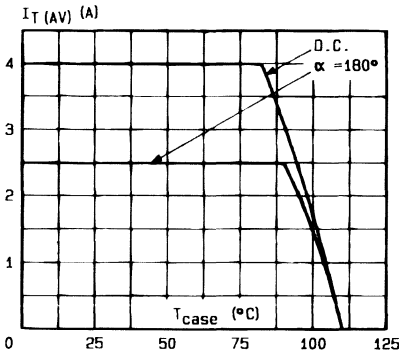

Fig. 3 - Mean on-state current versus case temperature.

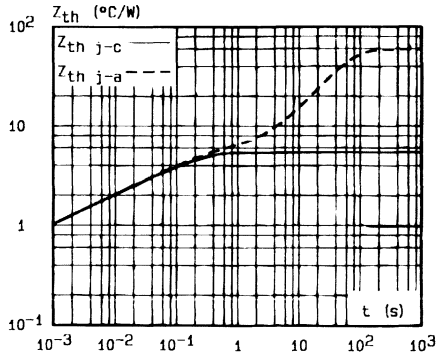

Fig. 4 - Thermal transient impedance junction to case and junction to ambient versus pulse duration.

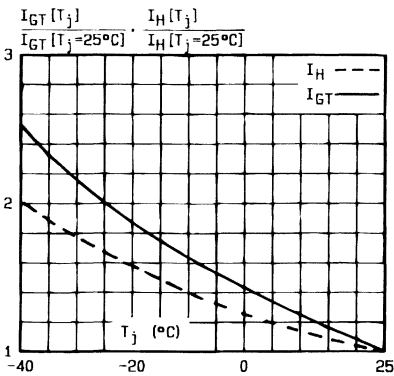

Fig. 5 - Relative variation of gate trigger current and holding current versus junction temperature.

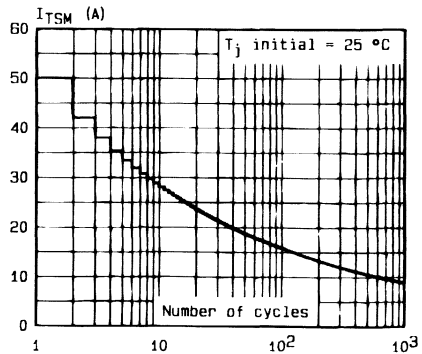

Fig. 6 - Non repetitive surge peak on-state current versus number of cycles.

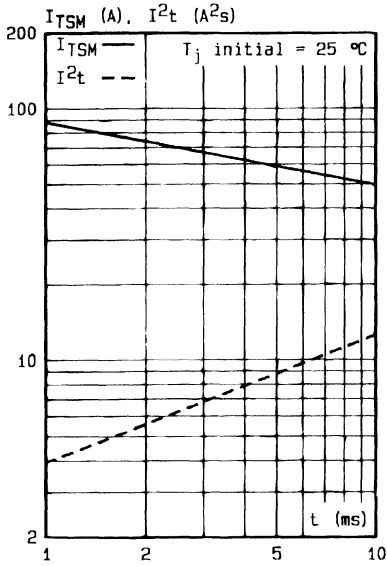

Fig.7 - Non repetitive surge peak on-state current for a sinusoidal pulse with width :  $t \leq 10$  ms, and corresponding value of  $I^2t$ .

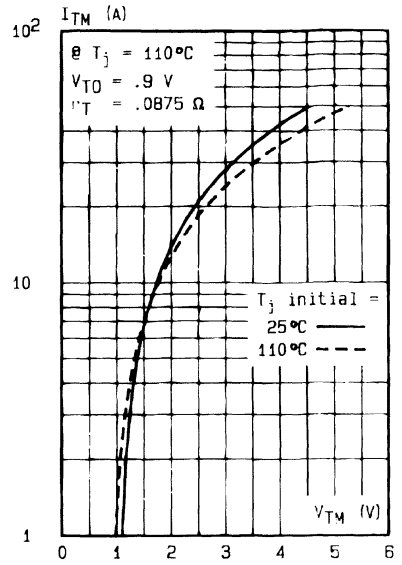
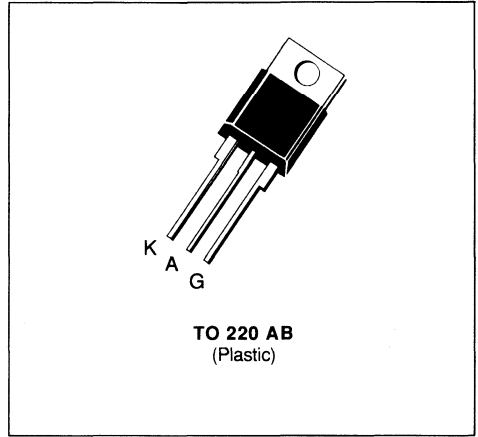

Fig.8 - On-state characteristics (maximum values).

## SENSITIVE GATE THYRISTORS

- OPERATES DIRECTLY FROM LOW SIGNAL
- GLASS PASSIVATED CHIP
- POSSIBILITY OF MOUNTING ON PRINTED CIRCUIT



### ABSOLUTE RATINGS (limiting values)

Symbol	Parameter	Value	Unit	
$I_T$ (RMS)	RMS on-state Current (1)	$T_c = 75\text{ }^\circ\text{C}$ 6	A	
$I_T$ (AV)	Mean on-state Current (1)	$T_c = 75\text{ }^\circ\text{C}$ 3.8	A	
$I_{TSM}$	Non Repetitive Surge Peak on-state Current ( $T_j$ initial = $25\text{ }^\circ\text{C}$ ) (2)	$t = 8.3\text{ ms}$	52	A
		$t = 10\text{ ms}$	50	
$I^2t$	$I^2t$ Value for Fusing	$t = 10\text{ ms}$	12.5	$\text{A}^2\text{s}$
$di/dt$	Critical Rate of Rise of on-state Current (3)	100	$\text{A}/\mu\text{s}$	
$T_{stg}$ $T_j$	Storage and Operating Junction Temperature Range	- 40 to 110	$^\circ\text{C}$	
		- 40 to 110	$^\circ\text{C}$	

Symbol	Parameter	TYS606-.. or TYS607-..						Unit
		05	1	2	4	6	8	
$V_{DRM}$ $V_{RRM}$	Repetitive Peak off-state Voltage (4)	50	100	200	400	600	800	V

(1) Single phase circuit,  $180^\circ$  conduction angle.

(2) Half sine wave.

(3)  $I_G = 5\text{ mA}$      $di/dt = 1\text{ A}/\mu\text{s}$ .

(4)  $T_j = 110\text{ }^\circ\text{C}$      $R_{GK} = 1\text{ K}\Omega$ .

### THERMAL RESISTANCES

Symbol	Parameter	Value	Unit
$R_{th(j-c)}$	Junction-case for DC	5.5	$^\circ\text{C}/\text{W}$
$R_{th(j-a)}$	Junction-ambient	60	$^\circ\text{C}/\text{W}$

**GATE CHARACTERISTICS** (maximum values)

$P_{GM} = 20 \text{ W}$  ( $t_p = 20 \mu\text{s}$ )

$I_{FGM} = 2 \text{ A}$  ( $t_p = 20 \mu\text{s}$ )

$V_{RGM} = 5 \text{ V}$

$P_{G(AV)} = 0.5 \text{ W}$

$V_{FGM} = 15 \text{ V}$  ( $t_p = 20 \mu\text{s}$ )

**ELECTRICAL CHARACTERISTICS**

Symbol	Types	Test Conditions			Min.	Typ.	Max.	Unit
$I_{GT}$	TYS606	$T_j = 25 \text{ }^\circ\text{C}$	$V_D = 12 \text{ V}$	$R_L = 140 \text{ } \Omega$			0.2	mA
	TYS607	Pulse Duration > 20 $\mu\text{s}$					0.5	
$V_{GT}$		$T_j = 25 \text{ }^\circ\text{C}$	$V_D = 12 \text{ V}$	$R_L = 140 \text{ } \Omega$			1.5	V
$V_{GD}$		$T_j = 110 \text{ }^\circ\text{C}$	$V_D = V_{DRM}$	$R_L = 3.3 \text{ k}\Omega$	0.1			V
$I_H$		$T_j = 25 \text{ }^\circ\text{C}$	$I_T = 50 \text{ mA}$	$R_{GK} = 1 \text{ k}\Omega$			6	mA
$I_L$		$T_j = 25 \text{ }^\circ\text{C}$	$V_D = 12 \text{ V}$	$I_G = 10 \text{ mA}$		10		mA
			Pulse Duration > 20 $\mu\text{s}$	$R_{GK} = 1 \text{ k}\Omega$				
$V_{TM}$		$T_j = 25 \text{ }^\circ\text{C}$	$I_{TM} = 12 \text{ A}$	$t_p = 10 \text{ ms}$			1.85	V
$I_{DRM}$		$V_{DRM}$ specified	$R_{GK} = 1 \text{ k}\Omega$	$T_j = 25 \text{ }^\circ\text{C}$			0.01	mA
				$T_j = 110 \text{ }^\circ\text{C}$			0.5	
$I_{RRM}$		$V_{RRM}$ specified	$R_{GK} = 1 \text{ k}\Omega$	$T_j = 25 \text{ }^\circ\text{C}$			0.01	mA
				$T_j = 110 \text{ }^\circ\text{C}$			0.5	
$t_{gt}$		$T_j = 25 \text{ }^\circ\text{C}$	$V_D = V_{DRM}$	$I_T = 12 \text{ A}$		1.5		$\mu\text{s}$
		$I_G = 10 \text{ mA}$	$di_G/dt = 0.15 \text{ A}/\mu\text{s}$					
$t_q$		$T_j = 110 \text{ }^\circ\text{C}$	$I_T = 12 \text{ A}$	$V_R = 24 \text{ V}$		100		$\mu\text{s}$
		$V_D = 67 \% V_{DRM}$	$di/dt = 10 \text{ A}/\mu\text{s}$	$dv/dt = 10 \text{ V}/\mu\text{s}$				
		$R_{GK} = 1 \text{ k}\Omega$						
$dv/dt^*$		$T_j = 110 \text{ }^\circ\text{C}$	$R_{GK} = 1 \text{ k}\Omega$			10		V/ $\mu\text{s}$
		Linear Slope up to $V_D = 67 \% V_{DRM}$						

\* For higher guaranteed values, please consult us.

**PACKAGE MECHANICAL DATA**

TO 220 AB Plastic

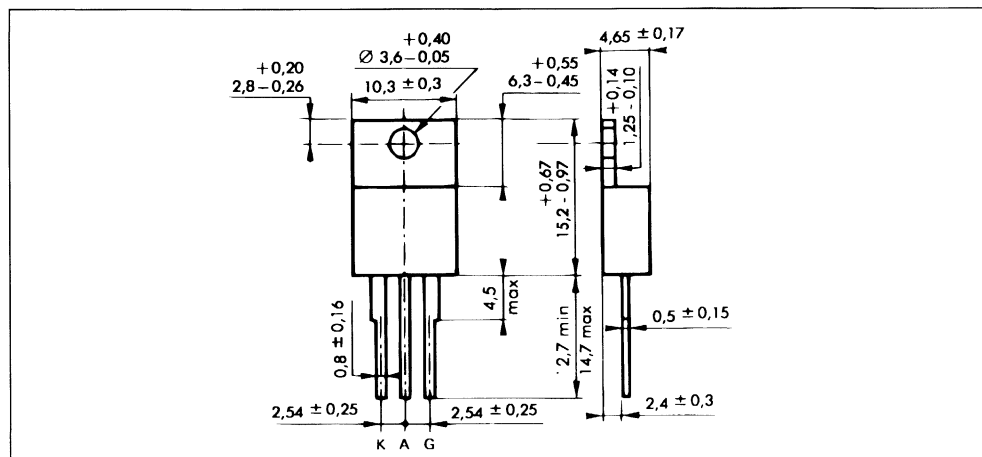



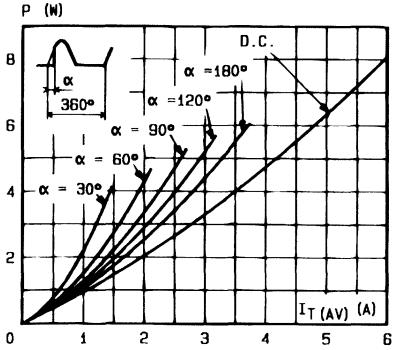

Fig.1 - Maximum mean power dissipation versus mean on-state current.

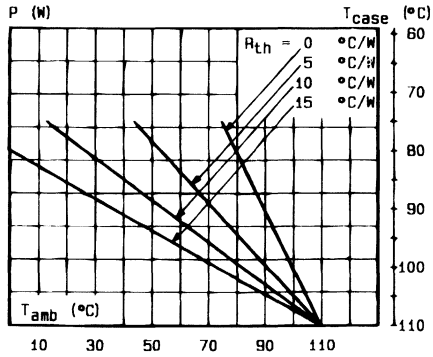

Fig.2 - Correlation between maximum mean power dissipation and maximum allowable temperatures ( $T_{amb}$  and  $T_{case}$ ) for different thermal resistances heatsink + contact.

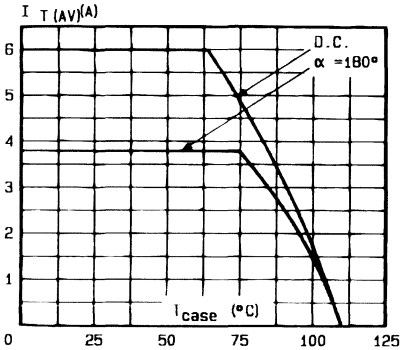

Fig.3 - Mean on-state current versus case temperature.

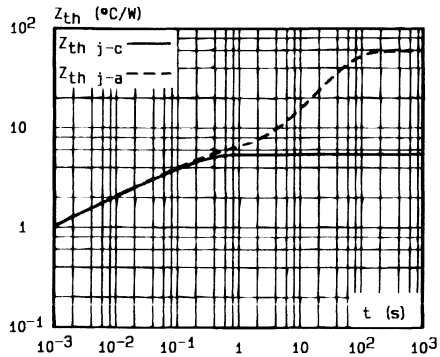

Fig.4 - Thermal transient impedance junction to case and junction to ambient versus pulse duration.

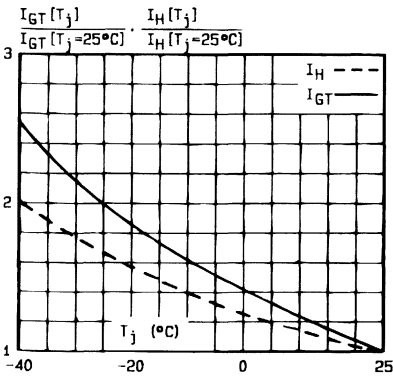

Fig.5 - Relative variation of gate trigger current and holding current versus junction temperature.

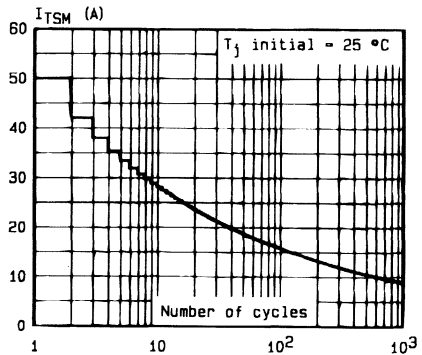

Fig.6 - Non repetitive surge peak on-state current versus number of cycles.

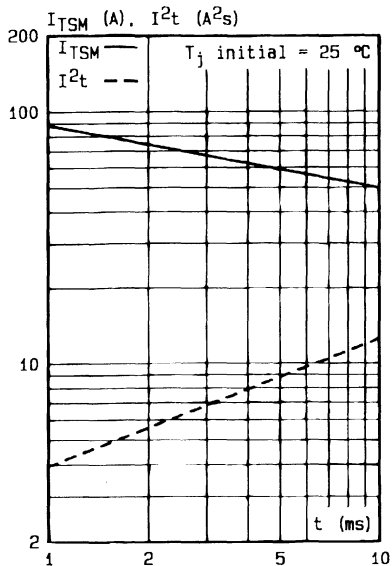

Fig. 7 - Non repetitive surge peak on-state current for a sinusoidal pulse with width :  $t \leq 10$  ms, and corresponding value of  $I^2t$ .

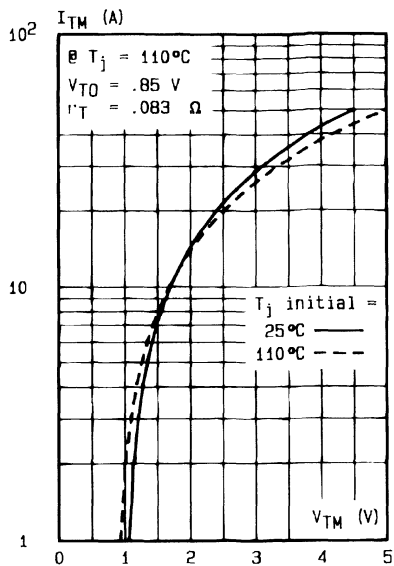

Fig. 8 - On-state characteristics (maximum values).

# **TRIAC DATASHEETS**



**TRIACS**

- GLASS PASSIVATED CHIP
- $I_{GT}$  SPECIFIED IN FOUR QUADRANTS
- INSULATING VOLTAGE : 2500  $V_{RMS}$
- UL RECOGNIZED (E81734)

**ADVANTAGES**

- $I_H < 13$  mA
- HIGH SURGE CURRENT :  $I_{TSM} = 50$  A

**DESCRIPTION**

Insulated triacs specified for light dimmer applications.

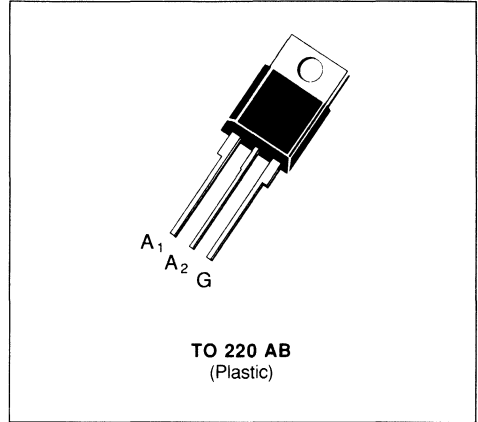
**ABSOLUTE RATINGS** (limiting values)

Symbol	Parameter	Value	Unit
$I_{T(RMS)}$	RMS on-state Current (360° conduction angle) $T_C = 75$ °C	4	A
$I_{TSM}$	Non Repetitive Surge Peak on-state Current ( $T_j$ initial = 25 °C - Half sine wave)	$t = 8.3$ ms	52
		$t = 10$ ms	50
$I^2t$	$I^2t$ Value for Fusing	$t = 10$ ms	$A^2s$
di/dt	Critical Rate of Rise of on-state Current (1)	Repetitive F = 50 Hz	10
		Non Repetitive	50
$T_{stg}$ $T_j$	Storage and Operating Junction Temperature Range	- 40 to 125	°C
		- 40 to 110	°C

Symbol	Parameter	BTA 04-			Unit
		200GP	400GP	600GP	
$V_{DRM}$	Repetitive Peak off-state Voltage (2)	200	400	600	V

(1)  $I_G = 750$  mA    di/dt = 1 A/ $\mu$ s

(2)  $T_j = 110$  °C.

**THERMAL RESISTANCES**

Symbol	Parameter	Value	Unit
$R_{th(j-a)}$	Junction to Ambient	60	°C/W
$R_{th(j-c)}$ DC	Junction to Case for DC	8.7	°C/W
$R_{th(j-c)}$ AC	Junction to Case for 360° Conduction Angle (F = 50 Hz)	6.5	°C/W

**GATE CHARACTERISTICS** (maximum values)

$P_{GM} = 40 \text{ W}$  ( $t_p = 10 \mu\text{s}$ )

$I_{GM} = 4 \text{ A}$  ( $t_p = 10 \mu\text{s}$ )

$P_{G(AV)} = 1 \text{ W}$

$V_{GM} = 16 \text{ V}$  ( $t_p = 10 \mu\text{s}$ )

**ELECTRICAL CHARACTERISTICS**

Symbol	Test Conditions			Quadrants	Min.	Typ.	Max.	Unit
$I_{GT}$	$T_j = 25 \text{ }^\circ\text{C}$ Pulse Duration > 20 $\mu\text{s}$	$V_D = 12 \text{ V}$	$R_L = 33 \text{ } \Omega$	I-II-III		15	50	mA
				IV		25	75	
$V_{GT}$	$T_j = 25 \text{ }^\circ\text{C}$ Pulse Duration > 20 $\mu\text{s}$	$V_D = 12 \text{ V}$	$R_L = 33 \text{ } \Omega$	I-II-III-IV			1.5	V
$V_{GD}$	$T_j = 110 \text{ }^\circ\text{C}$	$V_D = V_{DRM}$	$R_L = 3.3 \text{ k}\Omega$	I-II-III-IV	0.2			V
$I_{H^*}$	$T_j = 25 \text{ }^\circ\text{C}$	$I_T = 100 \text{ mA}$	Gate Open				13	mA
$I_L$	$T_j = 25 \text{ }^\circ\text{C}$ Pulse Duration > 20 $\mu\text{s}$	$V_D = 12 \text{ V}$	$I_G = 150 \text{ mA}$	I-III-IV		25		mA
				II		50		
$V_{TM}^*$	$T_j = 25 \text{ }^\circ\text{C}$	$I_{TM} = 5.5 \text{ A}$	$t_p = 10 \text{ ms}$				1.65	V
$I_{DRM}^*$	$V_{DRM}$ Specified						0.01	mA
$I_{DRM}^*$							0.5	mA
$dv/dt^*$	$T_j = 110 \text{ }^\circ\text{C}$	Gate Open			10			V/ $\mu\text{s}$
	Linear Slope up to $V_D = 67\% V_{DRM}$							
$(dv/dt)_c^*$	$T_C = 75 \text{ }^\circ\text{C}$	$V_D = V_{DRM}$	$I_T = 5.5 \text{ A}$			1		V/ $\mu\text{s}$
	$(di/dt)_c = 1.8 \text{ A/ms}$							
$t_{gt}$	$T_j = 25 \text{ }^\circ\text{C}$	$V_D = V_{DRM}$	$I_T = 5.5 \text{ A}$	I-II-III-IV				$\mu\text{s}$

\* For either polarity of electrode  $A_2$  voltage with reference to electrode  $A_1$ .

**PACKAGE MECHANICAL DATA**

TO 220 AB Plastic

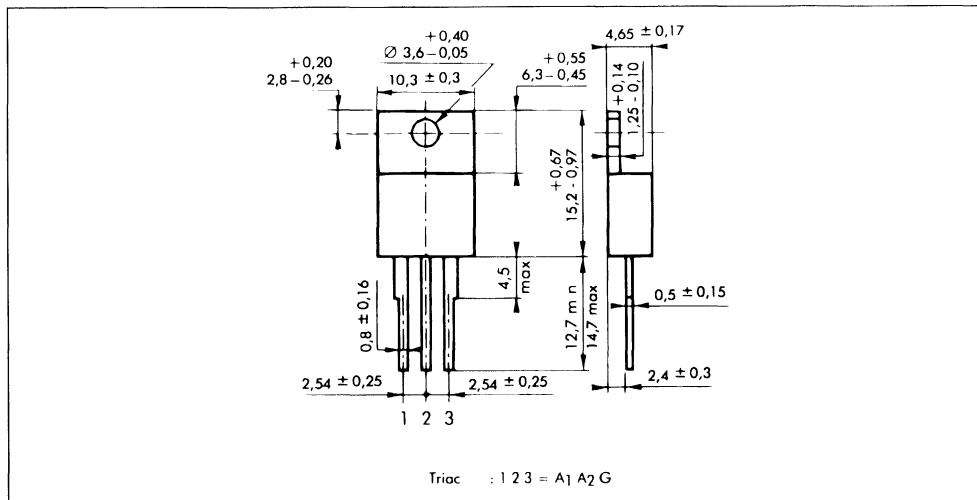

Cooling method : by conduction (method C)

Marking : type number

Weight : 2 g.

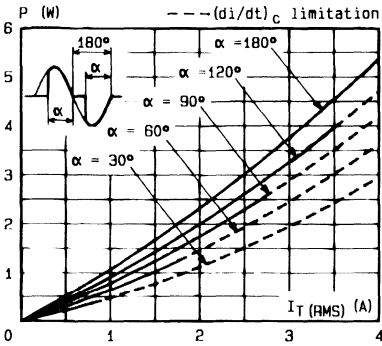

Fig. 1 - Maximum mean power dissipation versus RMS on-state current ( $F = 60$  Hz).

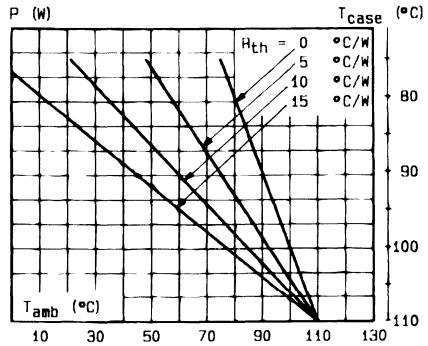

Fig. 2 - Correlation between maximum mean power dissipation and maximum allowable temperatures ( $T_{amb}$  and  $T_{case}$ ) for different thermal resistances heatsink + contact.

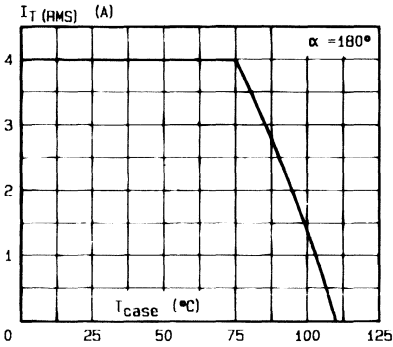

Fig. 3 - RMS on-state current versus case temperature.

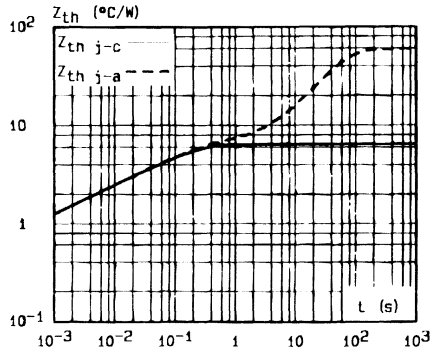

Fig. 4 - Thermal transient impedance junction to case and junction to ambient versus pulse duration.

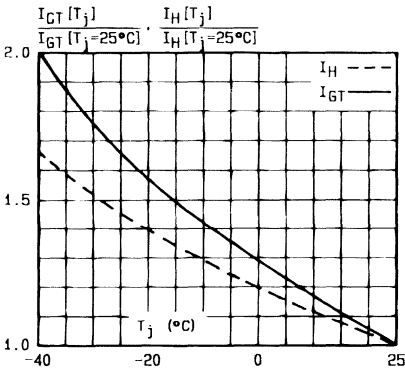

Fig. 5 - Relative variation of gate trigger current and holding current versus junction temperature.

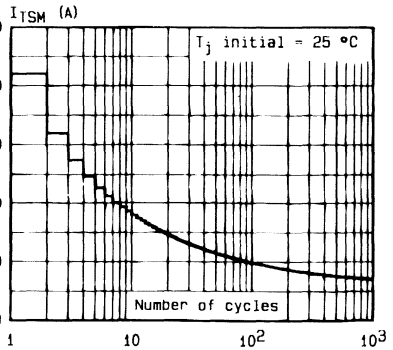

Fig. 6 - Non repetitive surge peak on-state current versus number of cycles.

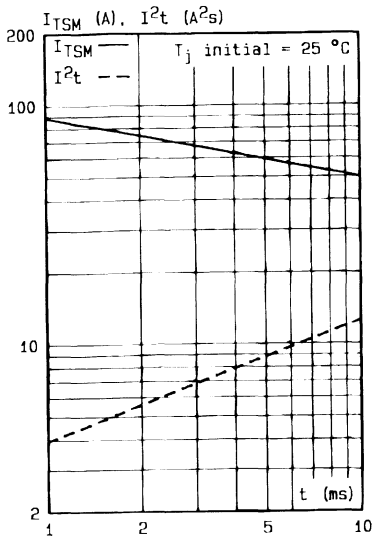

Fig.7 - Non repetitive surge peak on-state current for a sinusoidal pulse with width :  $t \leq 10$  ms, and corresponding value of  $I^2t$ .

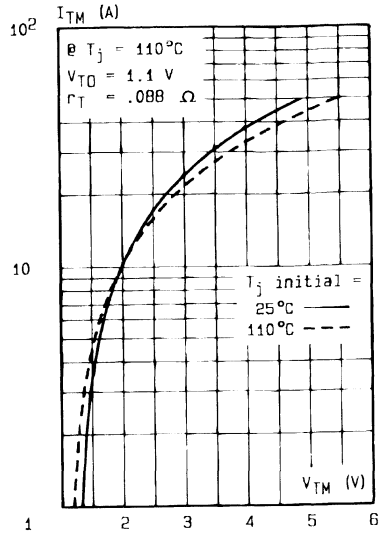
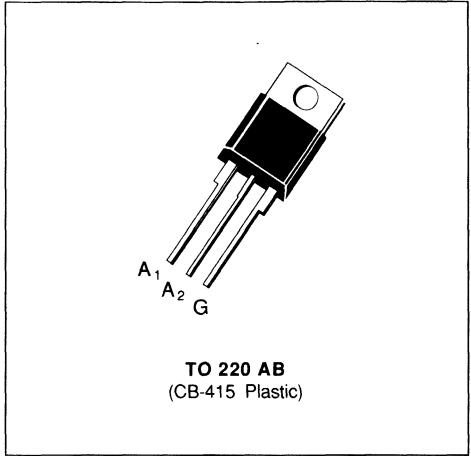

Fig.8 - On-state characteristics (maximum values).



**SNUBBERLESS TRIACS**

- $I_{TRMS} = 6 \text{ A}$  at  $T_c = 95 \text{ }^\circ\text{C}$ .
- $V_{DRM} : 200 \text{ V}$  to  $800 \text{ V}$ .
- $I_{GT} = 75 \text{ mA}$  (QI-II-III).
- GLASS PASSIVATED CHIP.
- HIGH SURGE CURRENT :  $I_{TSM} = 60 \text{ A}$ .
- HIGH COMMUTATION CAPABILITY :  
 $(di/dt)_c > 8 \text{ A / ms}$  without snubber.
- INSULATING VOLTAGE :  $2500 \text{ V}_{RMS}$ .

**DESCRIPTION**

New range suited for applications such as phase control and static switching on inductive or resistive load.

**ABSOLUTE RATINGS** (limiting values)

Symbol	Parameter		Value	Unit
$I_{TRMS}$	RMS on-state current (360 ° conduction angle)		$T_c = 95 \text{ }^\circ\text{C}$ 6	A
$I_{TSM}$	Non repetitive surge peak on-state current ( $T_j$ initial = $25 \text{ }^\circ\text{C}$ )		$t = 8.3 \text{ ms}$ 63	A
			$t = 10 \text{ ms}$ 60	
$I^2 t$	$I^2 t$ value		$t = 10 \text{ ms}$ 18	$\text{A}^2 \text{ s}$
$di/dt$	Critical rate of rise of on-state current (1)		Repetitive $F = 50 \text{ Hz}$ 20	A/ $\mu\text{s}$
			Non Repetitive 100	
$T_{stg}$ $T_j$	Storage and operating junction temperature range		- 40, + 150 - 40, + 125	$^\circ\text{C}$ $^\circ\text{C}$

Symbol	Parameter	BTA 06-					Unit
		200 AW	400 AW	600 AW	700 AW	800 AW	
$V_{DRM}$	Repetitive peak off-state voltage (2)	$\pm 200$	$\pm 400$	$\pm 600$	$\pm 700$	$\pm 800$	V

(1) Gate supply :  $I_G = 750 \text{ mA} - di_G / dt = 1 \text{ A / } \mu\text{s}$ .  
 (2)  $T_j = 125 \text{ }^\circ\text{C}$ .

**THERMAL RESISTANCES**

Symbol	Parameter	Value	Unit
$R_{th(j-a)}$	Junction to ambient	60	°C/W
$R_{th(j-c)} DC$	Junction to case for DC	4.3	°C/W
$R_{th(j-c)} AC$	Junction to case for 360° conduction angle (F = 50 Hz)	3.2	°C/W

**GATE CHARACTERISTICS (maximum values)**
 $P_{GM} = 40 W$  (t = 10  $\mu s$ )     $P_{G(AV)} = 1 W$      $I_{GM} = 4 A$  (t = 10  $\mu s$ )     $V_{GM} = 16 V$  (t = 10  $\mu s$ ).

**ELECTRICAL CHARACTERISTICS**

Symbol	Test Conditions			Quadrants	Min.	Typ.	Max.	Unit
$I_{GT}$	$T_j = 25\text{ }^\circ\text{C}$	$V_D = 12\text{ V}$ Pulse duration > 20 $\mu s$	$R_L = 33\ \Omega$	I-II-III	2		75	mA
$V_{GT}$	$T_j = 25\text{ }^\circ\text{C}$	$V_D = 12\text{ V}$ Pulse duration > 20 $\mu s$	$R_L = 33\ \Omega$	I-II-III			1.5	V
$V_{GD}$	$T_j = 125\text{ }^\circ\text{C}$	$V_D = V_{DRM}$ Pulse duration > 20 $\mu s$	$R_L = 3.3\text{ k}\Omega$	I-II-III	0.2			V
$I_{H^*}$	$T_j = 25\text{ }^\circ\text{C}$	$I_T = 100\text{ mA}$ Gate open	$R_L = 140\ \Omega$				75	mA
$I_L$	$T_j = 25\text{ }^\circ\text{C}$	$V_D = 12\text{ V}$ Pulse duration > 20 $\mu s$	$I_G = 500\text{ mA}$	I-III			75	mA
				II			150	
$V_{TM}^*$	$T_j = 25\text{ }^\circ\text{C}$	$I_{TM} = 8.5\text{ A}$	$t_p = 10\text{ ms}$				1.75	V
$I_{DRM}^*$	$T_j = 25\text{ }^\circ\text{C}$	$V_{DRM}$ rated	Gate open				0.01	mA
	$T_j = 125\text{ }^\circ\text{C}$						2	
$dv/dt^*$	$T_j = 125\text{ }^\circ\text{C}$	Gate open Linear slope up to 0.67 $V_{DRM}$			750	1000		V/ $\mu s$
$(di/dt)_c^*$	$T_j = 125\text{ }^\circ\text{C}$	$V_{DRM}$ rated Without snubber			8	16		A / ms
$t_{gt}$	$T_j = 25\text{ }^\circ\text{C}$	$di_G/dt = 3.5\text{ A}/\mu s$	$I_G = 500\text{ mA}$	I-II-III		2		$\mu s$

\* For either polarity of electrode A<sub>2</sub> voltage with reference to electrode A<sub>1</sub>.

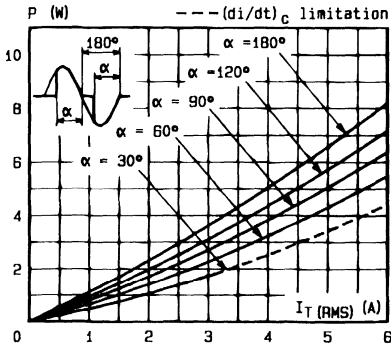

Fig. 1 - Maximum mean power dissipation versus RMS on-state current ( $F = 60$  Hz).

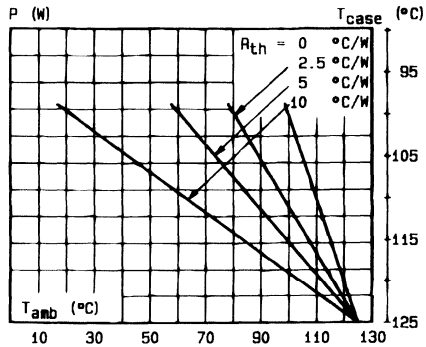

Fig. 2 - Correlation between maximum mean power dissipation and maximum allowable temperatures ( $T_{amb}$  and  $T_{case}$ ) for different thermal resistances heatsink + contact.

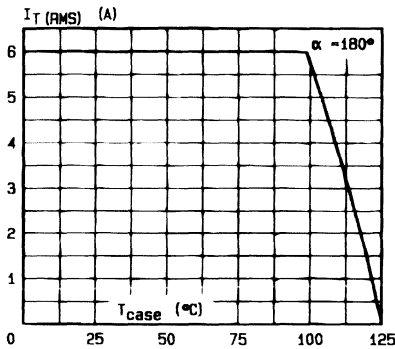

Fig. 3 - RMS on-state current versus case temperature.

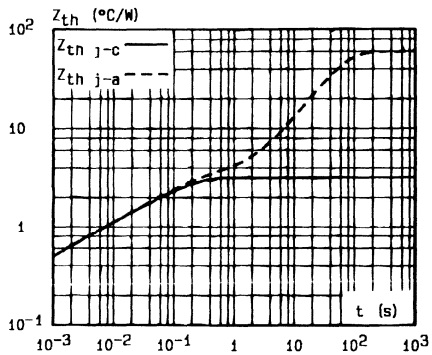

Fig. 4 - Thermal transient impedance junction to case and junction to ambient versus pulse duration.

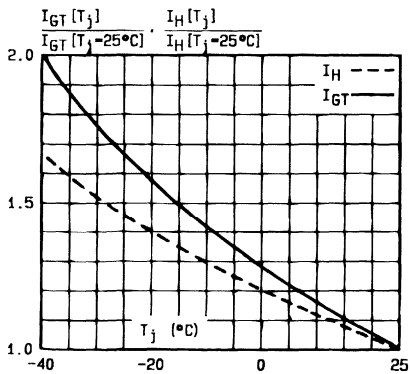

Fig. 5 - Relative variation of gate trigger current and holding current versus junction temperature.

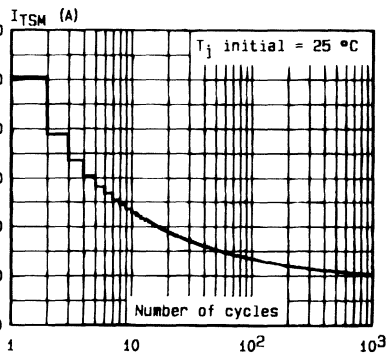

Fig. 6 - Non repetitive surge peak on-state current versus number of cycles.

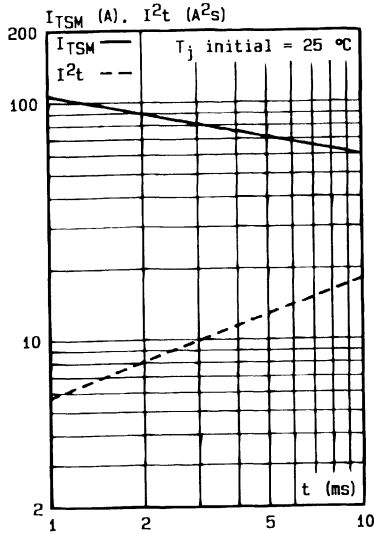

Fig.7 - Non repetitive surge peak on-state current for a sinusoidal pulse with width :  $t \leq 10 \text{ ms}$ , and corresponding value of  $I^2t$ .

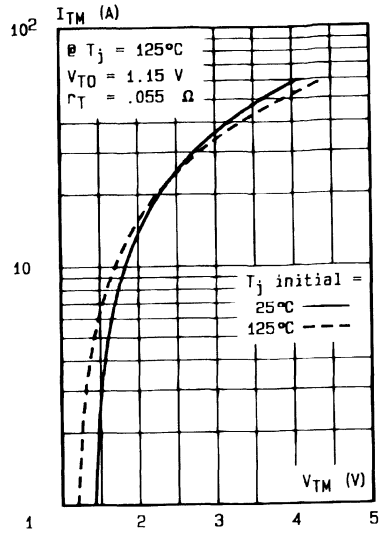
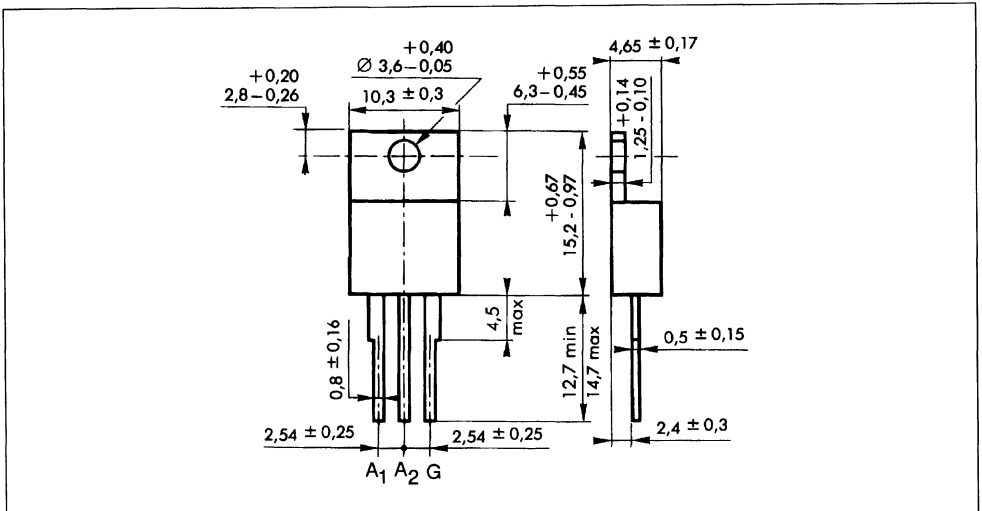

Fig.8 - On-state characteristics (maximum values).

D88BTA06ABCWP4

**PACKAGE MECHANICAL DATA**

TO 220 AB (CB-415) Plastic



Cooling method : by conduction (method C)  
 Marking : type number  
 Weight : 2 g

**SNUBBERLESS TRIACS**

- $I_{TRMS} = 6 \text{ A}$  at  $T_c = 95 \text{ }^\circ\text{C}$ .
- $V_{DRM} : 200 \text{ V}$  to  $800 \text{ V}$ .
- $I_{GT} = 50 \text{ mA}$  (QI-II-III).
- GLASS PASSIVATED CHIP.
- HIGH SURGE CURRENT :  $I_{TSM} = 60 \text{ A}$ .
- HIGH COMMUTATION CAPABILITY :  
 $(di/dt)_c > 5 \text{ A / ms}$  without snubber.
- INSULATING VOLTAGE :  $2500 \text{ V}_{RMS}$ .

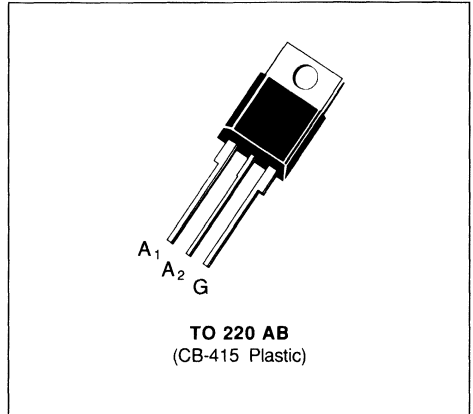
**DESCRIPTION**
**ABSOLUTE RATINGS** (limiting values)

Symbol	Parameter		Value	Unit
$I_{TRMS}$	RMS on-state current (360 ° conduction angle)	$T_c = 95 \text{ }^\circ\text{C}$	6	A
$I_{TSM}$	Non repetitive surge peak on-state current ( $T_j$ initial = $25 \text{ }^\circ\text{C}$ )	$t = 8.3 \text{ ms}$	63	A
		$t = 10 \text{ ms}$	60	
$I^2 t$	$I^2 t$ value	$t = 10 \text{ ms}$	18	$\text{A}^2 \text{ s}$
$di/dt$	Critical rate of rise of on-state current (1)	Repetitive $F = 50 \text{ Hz}$	20	A / $\mu\text{s}$
		Non Repetitive	100	
$T_{stg}$ $T_j$	Storage and operating junction temperature range		- 40, + 150 - 40, + 125	$^\circ\text{C}$ $^\circ\text{C}$

Symbol	Parameter	BTA 06-					Unit
		200 BW	400 BW	600 BW	700 BW	800 BW	
$V_{DRM}$	Repetitive peak off-state voltage (2)	$\pm 200$	$\pm 400$	$\pm 600$	$\pm 700$	$\pm 800$	V

(1) Gate supply :  $I_G = 500 \text{ mA} - di_G / dt = 1 \text{ A / } \mu\text{s}$ .

(2)  $T_j = 125 \text{ }^\circ\text{C}$ .

**THERMAL RESISTANCES**

Symbol	Parameter	Value	Unit
$R_{th(j-a)}$	Junction to ambient	60	°C/W
$R_{th(j-c) DC}$	Junction to case for DC	4.3	°C/W
$R_{th(j-c) AC}$	Junction to case for 360° conduction angle (F = 50 Hz)	3.2	°C/W

**GATE CHARACTERISTICS (maximum values)**

$P_{GM} = 40 W$  (t = 10 μs)    $P_{G(AV)} = 1 W$     $I_{GM} = 4 A$  (t = 10 μs)    $V_{GM} = 16 V$  (t = 10 μs).

**ELECTRICAL CHARACTERISTICS**

Symbol	Test Conditions	Quadrants	Min.	Typ.	Max.	Unit
$I_{GT}$	$T_j = 25\text{ °C}$ $V_D = 12 V$ $R_L = 33\ \Omega$ Pulse duration > 20 μs	I-II-III	2		50	mA
$V_{GT}$	$T_j = 25\text{ °C}$ $V_D = 12 V$ $R_L = 33\ \Omega$ Pulse duration > 20 μs	I-II-III			1.5	V
$V_{GD}$	$T_j = 125\text{ °C}$ $V_D = V_{DRM}$ $R_L = 3.3\ k\Omega$ Pulse duration > 20 μs	I-II-III	0.2			V
$I_H^*$	$T_j = 25\text{ °C}$ $I_T = 100\text{ mA}$ Gate open $R_L = 140\ \Omega$				50	mA
$I_L$	$T_j = 25\text{ °C}$ $V_D = 12 V$ $I_G = 500\text{ mA}$ Pulse duration > 20 μs	I-III		50		mA
		II		100		
$V_{TM}^*$	$T_j = 25\text{ °C}$ $I_{TM} = 8.5\text{ A}$ $t_p = 10\text{ ms}$				1.75	V
$I_{DRM}^*$	$T_j = 25\text{ °C}$ $T_j = 125\text{ °C}$	$V_{DRM}$ rated   Gate open			0.01	mA
					2	
$dv/dt^*$	$T_j = 125\text{ °C}$ Gate open Linear slope up to 0.67 $V_{DRM}$		500	750		V/μs
$(di/dt)_c^*$	$T_j = 125\text{ °C}$ $V_{DRM}$ rated Without snubber		5	10		A/ms
$t_{gt}$	$T_j = 25\text{ °C}$ $di_G/dt = 3.5\text{ A}/\mu\text{s}$ $I_G = 500\text{ mA}$ $I_T = 8.5\text{ A}$ $V_D = V_{DRM}$	I-II-III		2		μs

\* For either polarity of electrode A<sub>2</sub> voltage with reference to electrode A<sub>1</sub>.

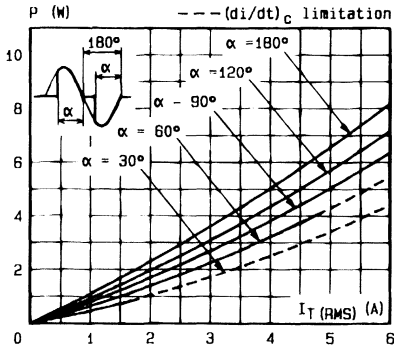

Fig. 1 - Maximum mean power dissipation versus RMS on-state current (F = 60 Hz).

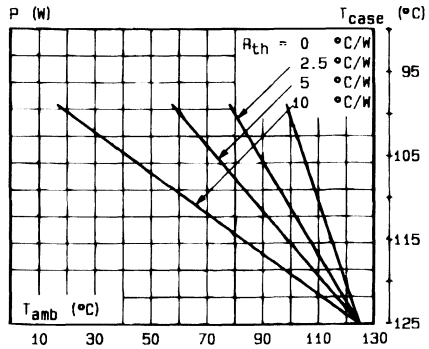

Fig. 2 - Correlation between maximum mean power dissipation and maximum allowable temperatures (T<sub>amb</sub> and T<sub>case</sub>) for different thermal resistances heatsink + contact.

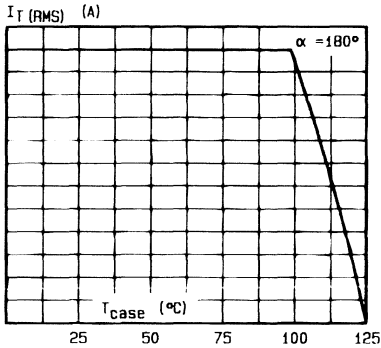

Fig. 3 - RMS on-state current versus case temperature.

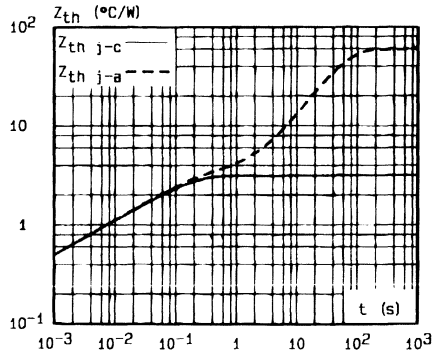

Fig. 4 - Thermal transient impedance junction to case and junction to ambient versus pulse duration.

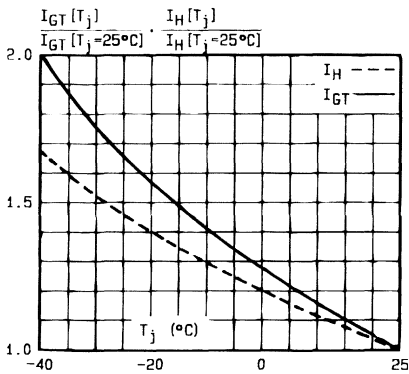

Fig. 5 - Relative variation of gate trigger current and holding current versus junction temperature.

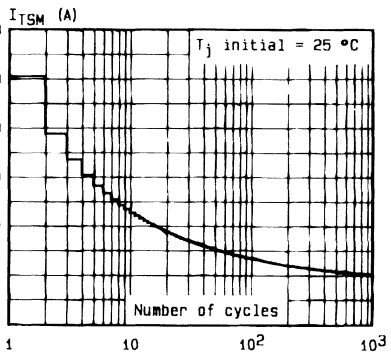

Fig. 6 - Non repetitive surge peak on-state current versus number of cycles.

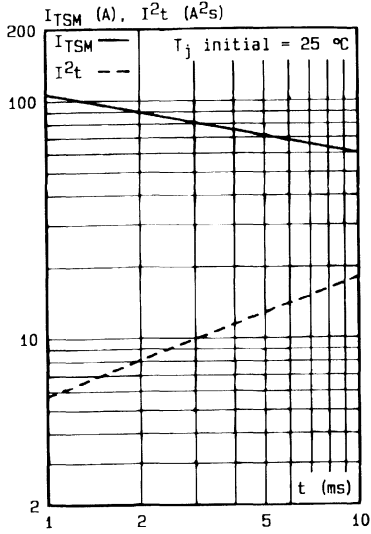

Fig.7 - Non repetitive surge peak on-state current for a sinusoidal pulse with width :  $t \leq 10$  ms, and corresponding value of  $I^2t$ .

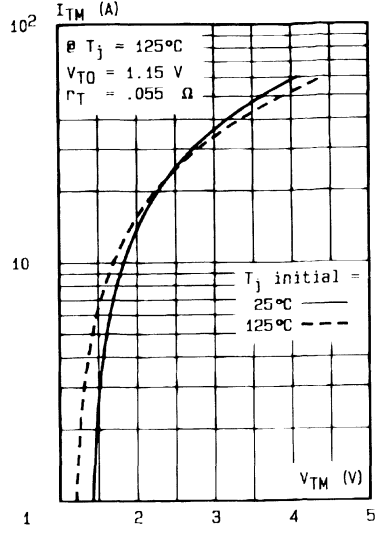
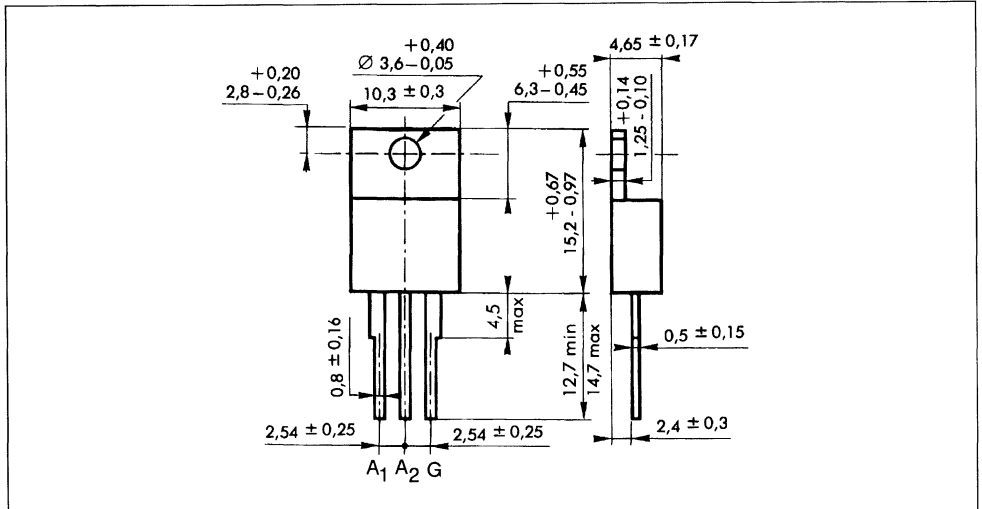

Fig.8 - On-state characteristics (maximum values).

PACKAGE MECHANICAL DATA

TO 220 AB (CB-415) Plastic



Cooling method : by conduction (method C)  
 Marking : type number  
 Weight : 2 g



**SNUBBERLESS TRIACS**

- $I_{TRMS} = 6$  A at  $T_c = 95$  °C.
- $V_{DRM} : 200$  V to 800 V.
- $I_{GT} = 35$  mA (QI-II-III).
- GLASS PASSIVATED CHIP.
- HIGH SURGE CURRENT :  $I_{TSM} = 60$  A.
- HIGH COMMUTATION CAPABILITY :  
( $di/dt$ )<sub>c</sub> > 3.5 A / ms without snubber.
- INSULATING VOLTAGE : 2500  $V_{RMS}$ .

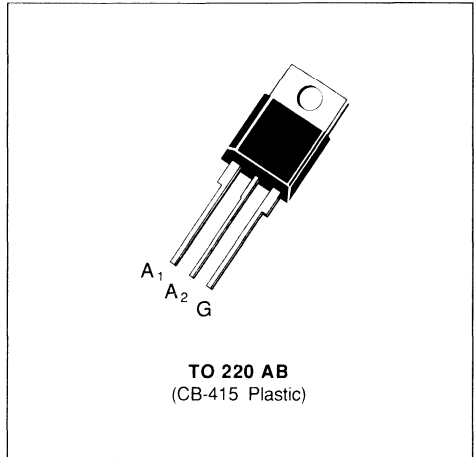
**DESCRIPTION**

New range suited for applications such as phase control and static switching on inductive or resistive load.

**ABSOLUTE RATINGS** (limiting values)

Symbol	Parameter		Value	Unit
$I_{TRMS}$	RMS on-state current (360 ° conduction angle)	$T_c = 95$ °C	6	A
$I_{TSM}$	Non repetitive surge peak on-state current ( $T_j$ initial = 25 °C)	$t = 8.3$ ms	63	A
		$t = 10$ ms	60	
$I^2 t$	$I^2 t$ value	$t = 10$ ms	18	A <sup>2</sup> s
$di/dt$	Critical rate of rise of on-state current (1)	Repetitive F = 50 Hz	20	A / $\mu$ s
		Non Repetitive	100	
$T_{stg}$ $T_j$	Storage and operating junction temperature range		- 40, + 150 - 40, + 125	°C °C

Symbol	Parameter	BTA 06-					Unit
		200 CW	400 CW	600 CW	700 CW	800 CW	
$V_{DRM}$	Repetitive peak off-state voltage (2)	± 200	± 400	± 600	± 700	± 800	V

(1) Gate supply :  $I_G = 350$  mA –  $di_G / dt = 1$  A /  $\mu$ s.

(2)  $T_j = 125$  °C.

**THERMAL RESISTANCES**

Symbol	Parameter	Value	Unit
$R_{th(j-a)}$	Junction to ambient	60	°C/W
$R_{th(j-c)} DC$	Junction to case for DC	4.3	°C/W
$R_{th(j-c)} AC$	Junction to case for 360° conduction angle (F = 50 Hz)	3.2	°C/W

**GATE CHARACTERISTICS (maximum values)**

$P_{GM} = 40 W$  (t = 10 μs)    $P_{G(AV)} = 1 W$     $I_{GM} = 4 A$  (t = 10 μs)    $V_{GM} = 16 V$  (t = 10 μs).

**ELECTRICAL CHARACTERISTICS**

Symbol	Test Conditions	Quadrants	Min.	Typ.	Max.	Unit
$I_{GT}$	$T_j = 25\text{ °C}$ $V_D = 12 V$ $R_L = 33\ \Omega$ Pulse duration > 20 μs	I-II-III	1		35	mA
$V_{GT}$	$T_j = 25\text{ °C}$ $V_D = 12 V$ $R_L = 33\ \Omega$ Pulse duration > 20 μs	I-II-III			1.5	V
$V_{GD}$	$T_j = 125\text{ °C}$ $V_D = V_{DRM}$ $R_L = 3.3\ k\Omega$ Pulse duration > 20 μs	I-II-III	0.2			V
$I_{H^*}$	$T_j = 25\text{ °C}$ $I_T = 100\text{ mA}$ Gate open $R_L = 140\ \Omega$				35	mA
$I_L$	$T_j = 25\text{ °C}$ $V_D = 12 V$ $I_G = 350\text{ mA}$ Pulse duration > 20 μs	I-III			50	mA
		II			80	
$V_{TM}^*$	$T_j = 25\text{ °C}$ $I_{TM} = 8.5\text{ A}$ $t_p = 10\text{ ms}$				1.75	V
$I_{DRM}^*$	$T_j = 25\text{ °C}$ $T_j = 125\text{ °C}$ $V_{DRM}$ rated   Gate open				0.01	mA
					2	
$dv/dt^*$	$T_j = 125\text{ °C}$ Gate open Linear slope up to 0.67 $V_{DRM}$		250	500		V/μs
$(di/dt)_c^*$	$T_j = 125\text{ °C}$ $V_{DRM}$ rated Without snubber		3.5	7		A / ms
$t_{gt}$	$T_j = 25\text{ °C}$ $di_G/dt = 1\text{ A}/\mu\text{s}$ $I_G = 350\text{ mA}$ $I_T = 8.5\text{ A}$ $V_D = V_{DRM}$	I-II-III		2		μs

\* For either polarity of electrode A<sub>2</sub> voltage with reference to electrode A<sub>1</sub>.

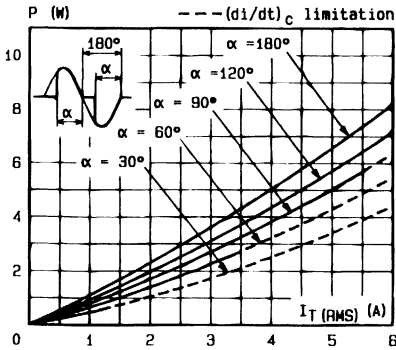

Fig.1 - Maximum mean power dissipation versus RMS on-state current ( $F = 60 \text{ Hz}$ ).

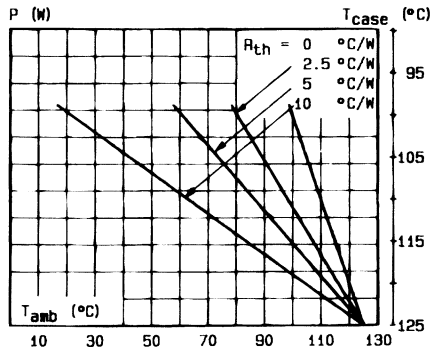

Fig.2 - Correlation between maximum mean power dissipation and maximum allowable temperatures ( $T_{amb}$  and  $T_{case}$ ) for different thermal resistances heatsink + contact.

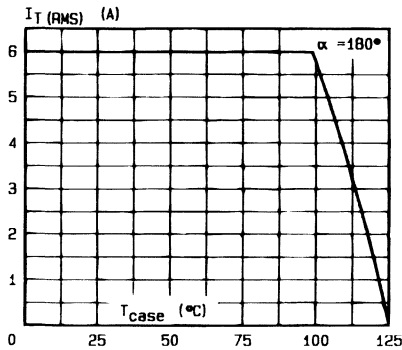

Fig.3 - RMS on-state current versus case temperature.

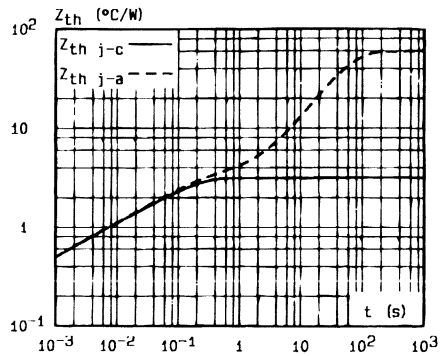

Fig.4 - Thermal transient impedance junction to case and junction to ambient versus pulse duration.

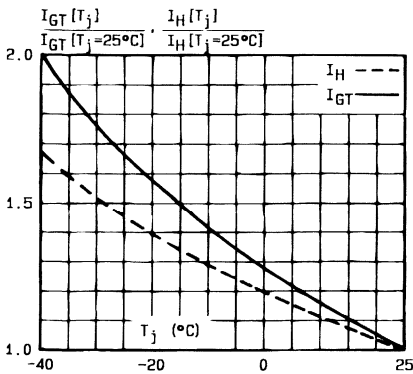

Fig.5 - Relative variation of gate trigger current and holding current versus junction temperature.

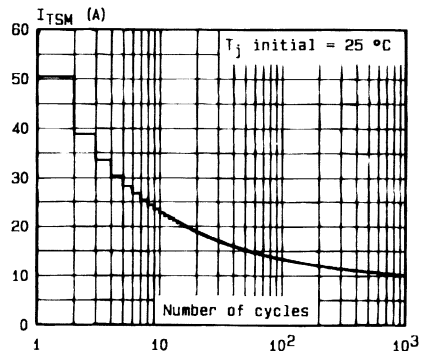

Fig.6 - Non repetitive surge peak on-state current versus number of cycles.

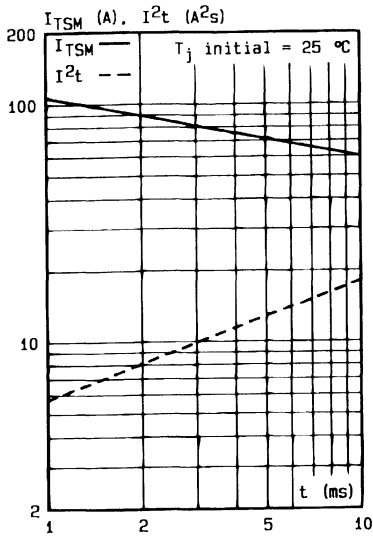

Fig.7 - Non repetitive surge peak on-state current for a sinusoidal pulse with width :  $t \leq 10 \text{ ms}$ , and corresponding value of  $I^2t$ .

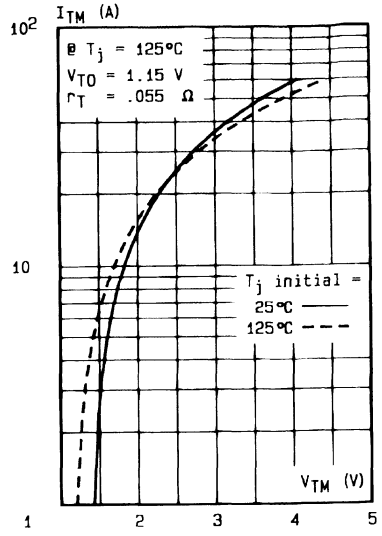
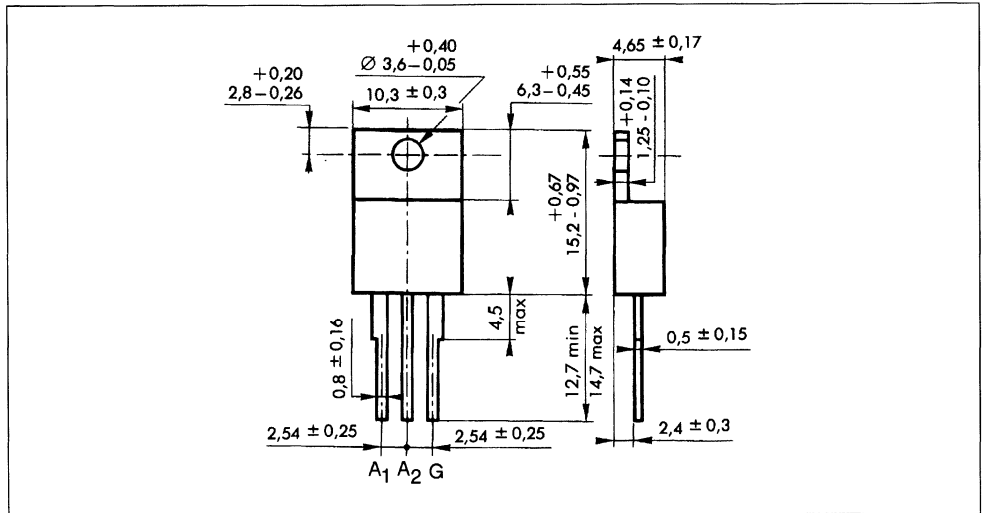

Fig.8 - On-state characteristics (maximum values).

**PACKAGE MECHANICAL DATA**

TO 220 AB (CB-415) Plastic



Cooling method : by conduction (method C)  
 Marking : type number  
 Weight : 2 g

## TRIACS

- GLASS PASSIVATED CHIP
- $I_{GT}$  SPECIFIED IN FOUR QUADRANTS
- INSULATING VOLTAGE : 2500  $V_{RMS}$
- UL RECOGNIZED (E81734)

### ADVANTAGES

- $I_H < 13$  mA
- HIGH SURGE CURRENT :  $I_{TSM} = 100$  A

### DESCRIPTION

Insulated triacs specified for light dimmer applications.

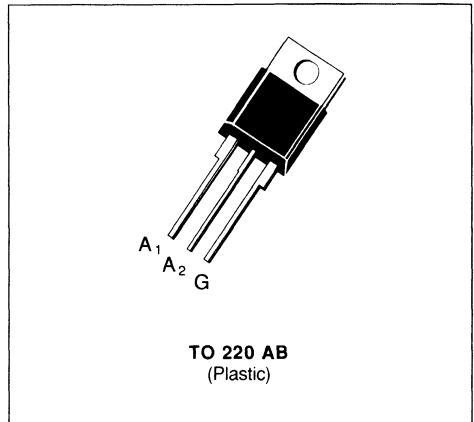

### ABSOLUTE RATINGS (limiting values)

Symbol	Parameter	Value	Unit
$I_{T(RMS)}$	RMS on-state Current (360° conduction angle)	$T_C = 85$ °C 6	A
$I_{TSM}$	Non Repetitive Surge Peak on-state Current ( $T_j$ initial = 25 °C - Half sine wave)	$t = 8.3$ ms	105
		$t = 10$ ms	100
$I^2t$	$I^2t$ Value for Fusing	$t = 10$ ms	50
di/dt	Critical Rate of Rise of on-state Current (1)	Repetitive F = 50 Hz	10
		Non Repetitive	50
$T_{stg}$	Storage and Operating Junction Temperature Range	- 40 to 125	°C
$T_j$		- 40 to 110	°C

Symbol	Parameter	BTA 06-			Unit
		200GP	400GP	600GP	
$V_{DRM}$	Repetitive Peak off-state Voltage (2)	200	400	600	V

(1)  $I_G = 750$  mA  $di_G/dt = 1$  A/ $\mu$ s

(2)  $T_j = 110$  °C.

### THERMAL RESISTANCES

Symbol	Parameter	Value	Unit
$R_{th(j-a)}$	Junction to Ambient	60	°C/W
$R_{th(j-c)} DC$	Junction to Case for DC	5.1	°C/W
$R_{th(j-c)} AC$	Junction to Case for 360° Conduction Angle (F = 50 Hz)	3.8	°C/W

**GATE CHARACTERISTICS** (maximum values)

$P_{GM} = 40 \text{ W}$  ( $t_p = 10 \mu\text{s}$ )       $I_{GM} = 4 \text{ A}$  ( $t_p = 10 \mu\text{s}$ )  
 $P_{G(AV)} = 1 \text{ W}$        $V_{GM} = 16 \text{ V}$  ( $t_p = 10 \mu\text{s}$ )

**ELECTRICAL CHARACTERISTICS**

Symbol	Test Conditions	Quadrants	Min.	Typ.	Max.	Unit	
$I_{GT}$	$T_j = 25 \text{ }^\circ\text{C}$ $V_D = 12 \text{ V}$ $R_L = 33 \text{ } \Omega$ Pulse Duration > 20 $\mu\text{s}$	I-II-III		15	50	mA	
		IV		25	75		
$V_{GT}$	$T_j = 25 \text{ }^\circ\text{C}$ $V_D = 12 \text{ V}$ $R_L = 33 \text{ } \Omega$ Pulse Duration > 20 $\mu\text{s}$	I-II-III-IV			1.5	V	
$V_{GD}$	$T_j = 110 \text{ }^\circ\text{C}$ $V_D = V_{DRM}$ $R_L = 3.3 \text{ k}\Omega$	I-II-III-IV	0.2			V	
$I_H^*$	$T_j = 25 \text{ }^\circ\text{C}$ $I_T = 100 \text{ mA}$ Gate Open				13	mA	
$I_L$	$T_j = 25 \text{ }^\circ\text{C}$ $V_D = 12 \text{ V}$ $I_G = 150 \text{ mA}$ Pulse Duration > 20 $\mu\text{s}$	I-III-IV		25		mA	
		II		50			
$V_{TM}^*$	$T_j = 25 \text{ }^\circ\text{C}$ $I_{TM} = 8.5 \text{ A}$ $t_p = 10 \text{ ms}$				1.4	V	
$I_{DRM}^*$	$V_{DRM}$ Specified					$T_j = 25 \text{ }^\circ\text{C}$	0.01
						$T_j = 110 \text{ }^\circ\text{C}$	0.5
$dv/dt^*$	$T_j = 110 \text{ }^\circ\text{C}$ Gate Open Linear Slope up to $V_D = 67\% V_{DRM}$		30	100		V/ $\mu\text{s}$	
$(dv/dt)_c^*$	$T_C = 85 \text{ }^\circ\text{C}$ $V_D = V_{DRM}$ $I_T = 8.5 \text{ A}$ $(di/dt)_c = 1.8 \text{ A/ms}$		1	10		V/ $\mu\text{s}$	
$t_{gt}$	$T_j = 25 \text{ }^\circ\text{C}$ $V_D = V_{DRM}$ $I_T = 8.5 \text{ A}$ $I_G = 100 \text{ mA}$ $di_G/dt = 1 \text{ A}/\mu\text{s}$	I-II-III-IV		2		$\mu\text{s}$	

\* For either polarity of electrode A<sub>2</sub> voltage with reference to electrode A<sub>1</sub>.

**PACKAGE MECHANICAL DATA**

TO 220 AB Plastic

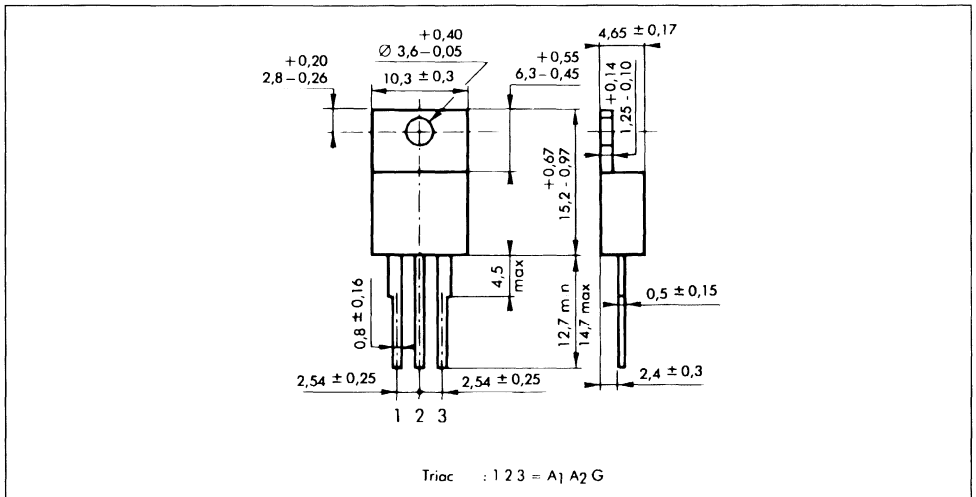

Cooling method : by conduction (method C)

Marking : type number

Weight : 2 g.

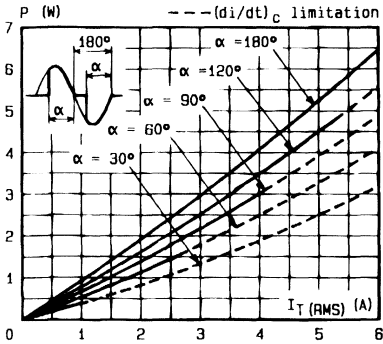

Fig. 1 - Maximum mean power dissipation versus RMS on-state current ( $F = 60 \text{ Hz}$ ).

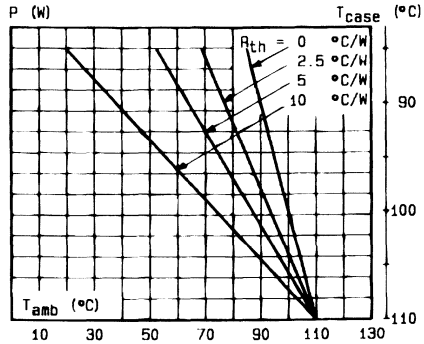

Fig. 2 - Correlation between maximum mean power dissipation and maximum allowable temperatures ( $T_{amb}$  and  $T_{case}$ ) for different thermal resistances heatsink + contact.

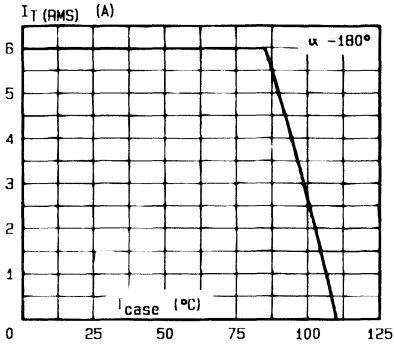

Fig. 3 - RMS on-state current versus case temperature.

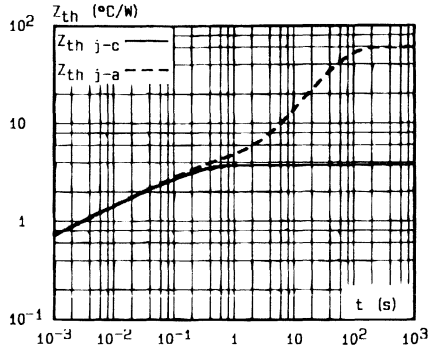

Fig. 4 - Thermal transient impedance junction to case and junction to ambient versus pulse duration.

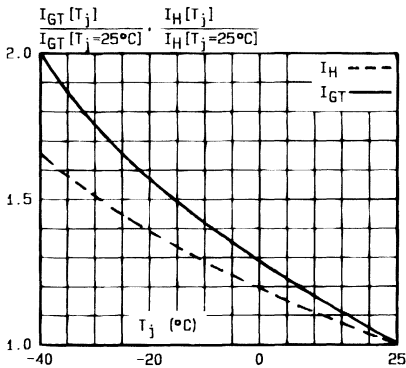

Fig. 5 - Relative variation of gate trigger current and holding current versus junction temperature.

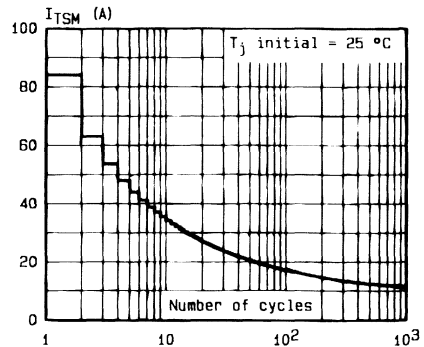

Fig. 6 - Non repetitive surge peak on-state current versus number of cycles.

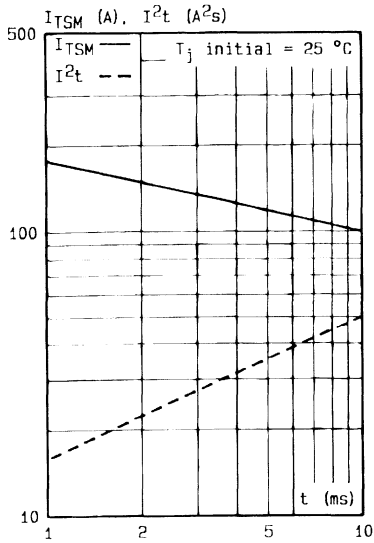

Fig.7 - Non repetitive surge peak on-state current for a sinusoidal pulse with width :  $t \leq 10$  ms, and corresponding value of  $I^2t$ .

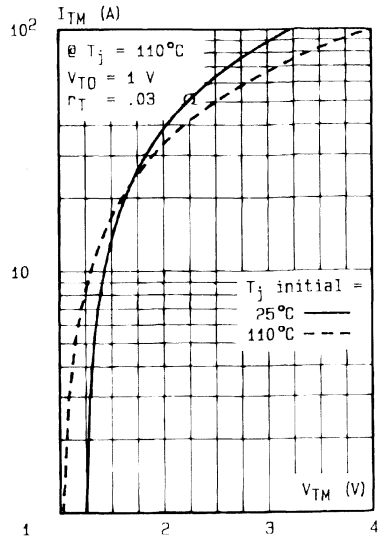
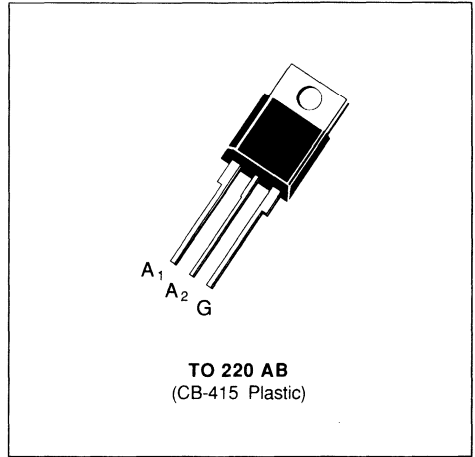

Fig.8 - On-state characteristics (maximum values)



**SNUBBERLESS TRIACS**

- $I_{TRMS} = 8\text{ A}$  at  $T_c = 90\text{ }^\circ\text{C}$ .
- $V_{DRM} : 200\text{ V}$  to  $800\text{ V}$ .
- $I_{GT} = 75\text{ mA}$  (QI-II-III).
- GLASS PASSIVATED CHIP.
- HIGH SURGE CURRENT :  $I_{TSM} = 80\text{ A}$ .
- HIGH COMMUTATION CAPABILITY :  
 $(di/dt)_c > 10\text{ A/ms}$  without snubber.
- INSULATING VOLTAGE :  $2500\text{ V}_{RMS}$ .

**DESCRIPTION**

New range suited for applications such as phase control and static switching on inductive or resistive load.

**ABSOLUTE RATINGS** (limiting values)

Symbol	Parameter		Value	Unit
$I_{TRMS}$	RMS on-state current (360 ° conduction angle)	$T_c = 90\text{ }^\circ\text{C}$	8	A
$I_{TSM}$	Non repetitive surge peak on-state current ( $T_j$ initial = $25\text{ }^\circ\text{C}$ )	$t = 8.3\text{ ms}$	85	A
		$t = 10\text{ ms}$	80	
$I^2t$	$I^2t$ value	$t = 10\text{ ms}$	32	$\text{A}^2\text{s}$
$di/dt$	Critical rate of rise of on-state current (1)	Repetitive $F = 50\text{ Hz}$	20	A/ $\mu\text{s}$
		Non Repetitive	100	
$T_{stg}$ $T_j$	Storage and operating junction temperature range		- 40, + 150	$^\circ\text{C}$
			- 40, + 125	$^\circ\text{C}$

Symbol	Parameter	BTA 08-					Unit
		200 AW	400 AW	600 AW	700 AW	800 AW	
$V_{DRM}$	Repetitive peak off-state voltage (2)	$\pm 200$	$\pm 400$	$\pm 600$	$\pm 700$	$\pm 800$	V

(1) Gate supply :  $I_G = 750\text{ mA}$  -  $di_G / dt = 1\text{ A} / \mu\text{s}$ .

(2)  $T_j = 125\text{ }^\circ\text{C}$ .

**THERMAL RESISTANCES**

Symbol	Parameter	Value	Unit
$R_{th(j-a)}$	Junction to ambient	60	°C/W
$R_{th(j-c)}$ DC	Junction to case for DC	4.3	°C/W
$R_{th(j-c)}$ AC	Junction to case for 360 ° conduction angle (F = 50 Hz)	3.2	°C/W

**GATE CHARACTERISTICS (maximum values)**
 $P_{GM} = 40 \text{ W (} t = 10 \mu\text{s)}$     $P_{G(AV)} = 1 \text{ W}$     $I_{GM} = 4 \text{ A (} t = 10 \mu\text{s)}$     $V_{GM} = 16 \text{ V (} t = 10 \mu\text{s)}$ .

**ELECTRICAL CHARACTERISTICS**

Symbol	Test Conditions			Quadrants	Min.	Typ.	Max.	Unit
$I_{GT}$	$T_j = 25 \text{ °C}$	$V_D = 12 \text{ V}$ Pulse duration > 20 $\mu\text{s}$	$R_L = 33 \text{ }\Omega$	I-II-III	2		75	mA
$V_{GT}$	$T_j = 25 \text{ °C}$	$V_D = 12 \text{ V}$ Pulse duration > 20 $\mu\text{s}$	$R_L = 33 \text{ }\Omega$	I-II-III			1.5	V
$V_{GD}$	$T_j = 125 \text{ °C}$	$V_D = V_{DRM}$ Pulse duration > 20 $\mu\text{s}$	$R_L = 3.3 \text{ k}\Omega$	I-II-III	0.2			V
$I_H^*$	$T_j = 25 \text{ °C}$	Gate open $I_T = 100 \text{ mA}$ $R_L = 140 \text{ }\Omega$					75	mA
$I_L$	$T_j = 25 \text{ °C}$	$V_D = 12 \text{ V}$ Pulse duration > 20 $\mu\text{s}$	$I_G = 500 \text{ mA}$	I-III		75		mA
				II		150		
$V_{TM}^*$	$T_j = 25 \text{ °C}$	$I_{TM} = 11 \text{ A}$	$t_p = 10 \text{ ms}$				1.75	V
$I_{DRM}^*$	$T_j = 25 \text{ °C}$	$V_{DRM}$ rated	Gate open				0.01	mA
	$T_j = 125 \text{ °C}$						2	
$dv/dt^*$	$T_j = 125 \text{ °C}$	Gate open Linear slope up to 0.67 $V_{DRM}$			750	1000		V/ $\mu\text{s}$
$(di/dt)_c^*$	$T_j = 125 \text{ °C}$	$V_{DRM}$ rated Without snubber			10	20		A/ms
$t_{gt}$	$T_j = 25 \text{ °C}$ $I_T = 11 \text{ A}$	$di_G/dt = 3.5 \text{ A}/\mu\text{s}$ $V_D = V_{DRM}$	$I_G = 500 \text{ mA}$	I-II-III		2		$\mu\text{s}$

\* For either polarity of electrode  $A_2$  voltage with reference to electrode  $A_1$ .

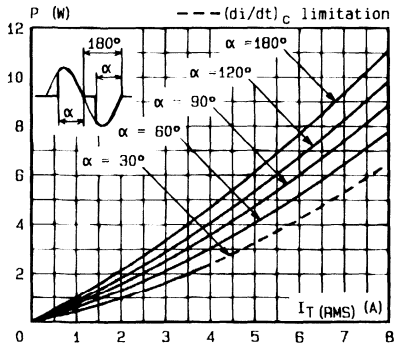

Fig.1 - Maximum mean power dissipation versus RMS on-state current (F = 60 Hz).

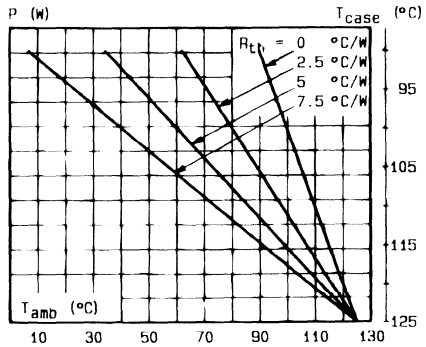

Fig.2 - Correlation between maximum mean power dissipation and maximum allowable temperatures ( $T_{amb}$  and  $T_{case}$ ) for different thermal resistances heatsink + contact.

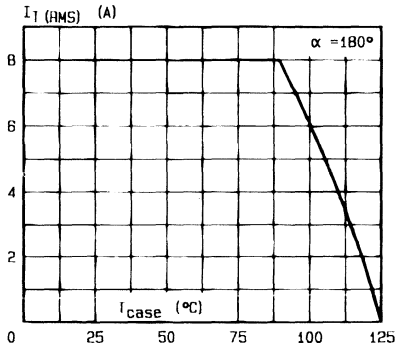

Fig.3 - RMS on-state current versus case temperature.

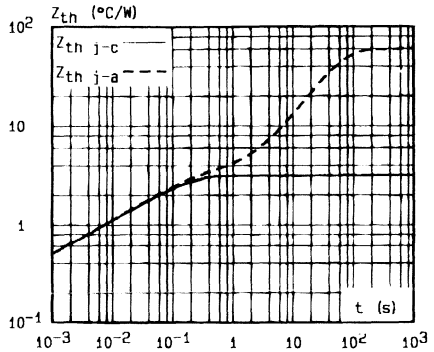

Fig.4 - Thermal transient impedance junction to case and junction to ambient versus pulse duration.

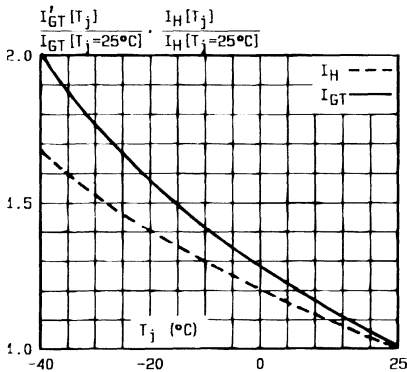

Fig.5 - Relative variation of gate trigger current and holding current versus junction temperature.

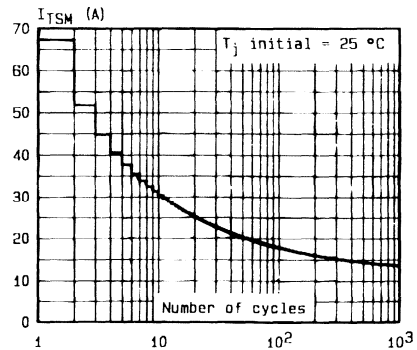

Fig.6 - Non repetitive surge peak on-state current versus number of cycles.

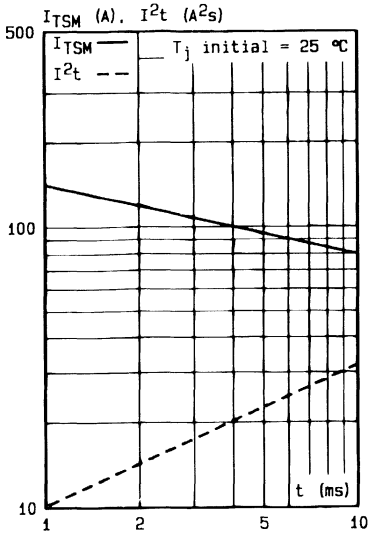

Fig.7 - Non repetitive surge peak on-state current for a sinusoidal pulse with width :  $t \leq 10$  ms, and corresponding value of  $I^2t$ .

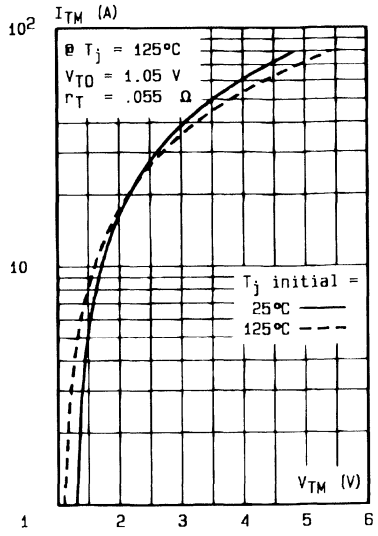
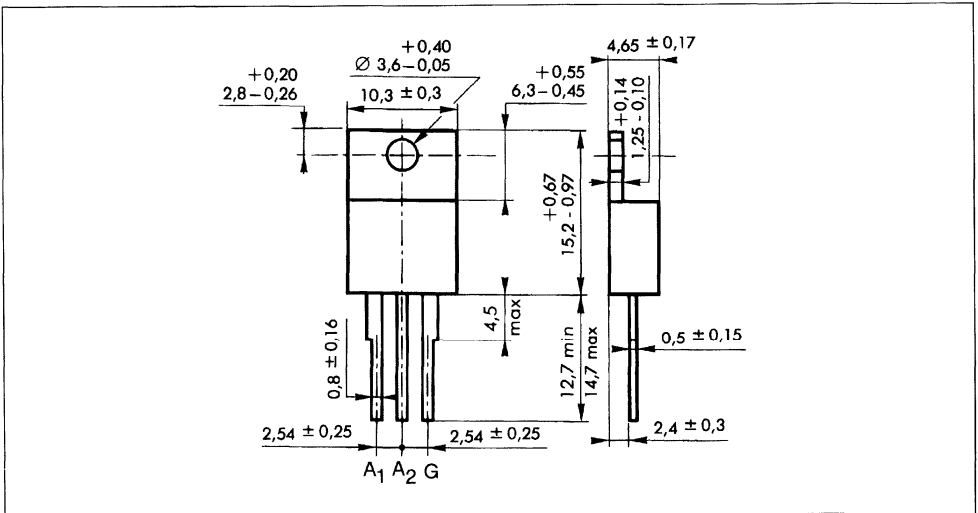

Fig.8 - On-state characteristics (maximum values).

**PACKAGE MECHANICAL DATA**

TO 220 AB (CB-415) Plastic



Cooling method : by conduction (method C)  
 Marking : type number  
 Weight : 2 g

## SNUBBERLESS TRIACS

- $I_{TRMS} = 8\text{ A}$  at  $T_c = 90\text{ }^\circ\text{C}$ .
- $V_{DRM} : 200\text{ V}$  to  $800\text{ V}$ .
- $I_{GT} = 50\text{ mA}$  (QI-II-III).
- GLASS PASSIVATED CHIP.
- HIGH SURGE CURRENT :  $I_{TSM} = 80\text{ A}$ .
- HIGH COMMUTATION CAPABILITY :  
( $di/dt$ )<sub>c</sub> >  $7\text{ A/ms}$  without snubber.
- INSULATING VOLTAGE :  $2500\text{ V}_{RMS}$ .

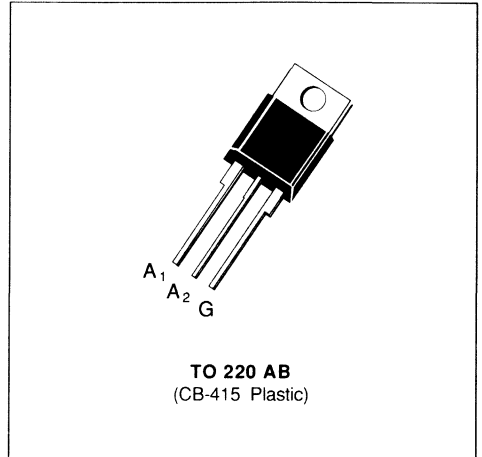

### DESCRIPTION

New range suited for applications such as phase control and static switching on inductive or resistive load.

### ABSOLUTE RATINGS (limiting values)

Symbol	Parameter	Value	Unit
$I_{TRMS}$	RMS on-state current (360 ° conduction angle)	$T_c = 90\text{ }^\circ\text{C}$ 8	A
$I_{TSM}$	Non repetitive surge peak on-state current ( $T_j$ initial = $25\text{ }^\circ\text{C}$ )	$t = 8.3\text{ ms}$	85
		$t = 10\text{ ms}$	80
$I^2t$	$I^2t$ value	$t = 10\text{ ms}$	32
$di/dt$	Critical rate of rise of on-state current (1)	Repetitive $F = 50\text{ Hz}$	20
		Non Repetitive	100
$T_{stg}$ $T_j$	Storage and operating junction temperature range	- 40, + 150 - 40, + 125	$^\circ\text{C}$ $^\circ\text{C}$

Symbol	Parameter	BTA 08-					Unit
		200 BW	400 BW	600 BW	700 BW	800 BW	
$V_{DRM}$	Repetitive peak off-state voltage (2)	$\pm 200$	$\pm 400$	$\pm 600$	$\pm 700$	$\pm 800$	V

(1) Gate supply :  $I_G = 500\text{ mA}$  –  $di_G / dt = 1\text{ A} / \mu\text{s}$ .

(2)  $T_j = 125\text{ }^\circ\text{C}$ .

## THERMAL RESISTANCES

Symbol	Parameter	Value	Unit
$R_{th(j-a)}$	Junction to ambient	60	$^{\circ}\text{C}/\text{W}$
$R_{th(j-c)} \text{ DC}$	Junction to case for DC	4.3	$^{\circ}\text{C}/\text{W}$
$R_{th(j-c)} \text{ AC}$	Junction to case for $360^{\circ}$ conduction angle ( $F = 50 \text{ Hz}$ )	3.2	$^{\circ}\text{C}/\text{W}$

## GATE CHARACTERISTICS (maximum values)

$P_{GM} = 40 \text{ W}$  ( $t = 10 \mu\text{s}$ )    $P_{G(AV)} = 1 \text{ W}$     $I_{GM} = 4 \text{ A}$  ( $t = 10 \mu\text{s}$ )    $V_{GM} = 16 \text{ V}$  ( $t = 10 \mu\text{s}$ ).

## ELECTRICAL CHARACTERISTICS

Symbol	Test Conditions			Quadrants	Min.	Typ.	Max.	Unit
$I_{GT}$	$T_j = 25^{\circ}\text{C}$	$V_D = 12 \text{ V}$	$R_L = 33 \Omega$	I-II-III	2		50	mA
	Pulse duration $> 20 \mu\text{s}$							
$V_{GT}$	$T_j = 25^{\circ}\text{C}$	$V_D = 12 \text{ V}$	$R_L = 33 \Omega$	I-II-III			1.5	V
	Pulse duration $> 20 \mu\text{s}$							
$V_{GD}$	$T_j = 125^{\circ}\text{C}$	$V_D = V_{DRM}$	$R_L = 3.3 \text{ k}\Omega$	I-II-III	0.2			V
	Pulse duration $> 20 \mu\text{s}$							
$I_H^*$	$T_j = 25^{\circ}\text{C}$	$I_T = 100 \text{ mA}$					50	mA
	Gate open	$R_L = 140 \Omega$						
$I_L$	$T_j = 25^{\circ}\text{C}$	$V_D = 12 \text{ V}$	$I_G = 500 \text{ mA}$	I-III		50		mA
				II		100		
	Pulse duration $> 20 \mu\text{s}$							
$V_{TM}^*$	$T_j = 25^{\circ}\text{C}$	$I_{TM} = 11 \text{ A}$	$t_p = 10 \text{ ms}$				1.75	V
$I_{DRM}^*$	$T_j = 25^{\circ}\text{C}$	$V_{DRM}$ rated	Gate open				0.01	mA
	$T_j = 125^{\circ}\text{C}$						2	
$dv/dt^*$	$T_j = 125^{\circ}\text{C}$	Gate open			500	750		V/ $\mu\text{s}$
	Linear slope up to $0.67 V_{DRM}$							
$(di/dt)_c^*$	$T_j = 125^{\circ}\text{C}$	$V_{DRM}$ rated			7	14		A/ms
	Without snubber							
$t_{gt}$	$T_j = 25^{\circ}\text{C}$	$di_G/dt = 3.5 \text{ A}/\mu\text{s}$	$I_G = 500 \text{ mA}$	I-II-III		2		$\mu\text{s}$
	$I_T = 11 \text{ A}$	$V_D = V_{DRM}$						

\* For either polarity of electrode  $A_2$  voltage with reference to electrode  $A_1$ .

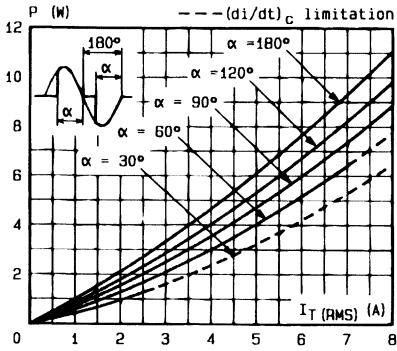

Fig.1 - Maximum mean power dissipation versus RMS on-state current ( $F = 60$  Hz).

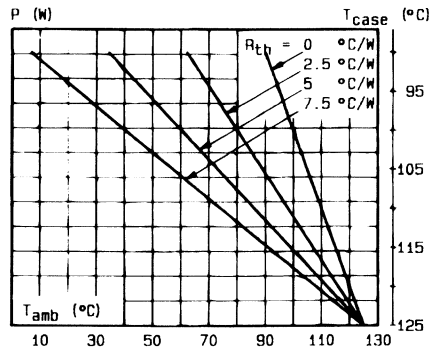

Fig.2 - Correlation between maximum mean power dissipation and maximum allowable temperatures ( $T_{amb}$  and  $T_{case}$ ) for different thermal resistances heatsink + contact.

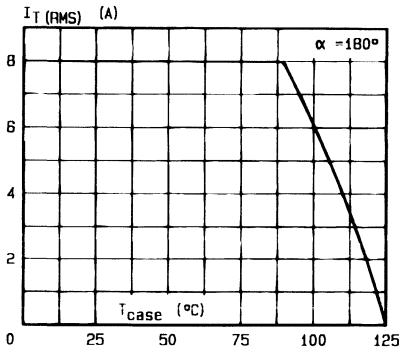

Fig.3 - RMS on-state current versus case temperature.

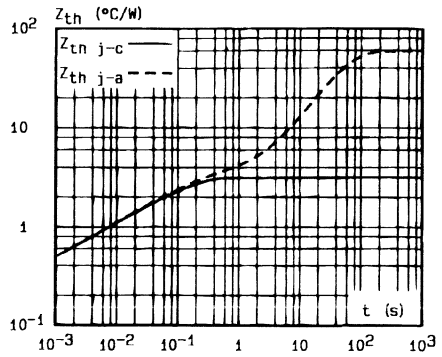

Fig.4 - Thermal transient impedance junction to case and junction to ambient versus pulse duration.

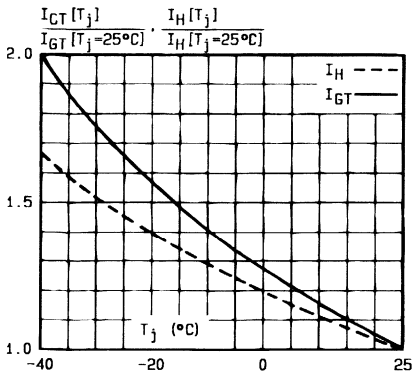

Fig.5 - Relative variation of gate trigger current and holding current versus junction temperature.

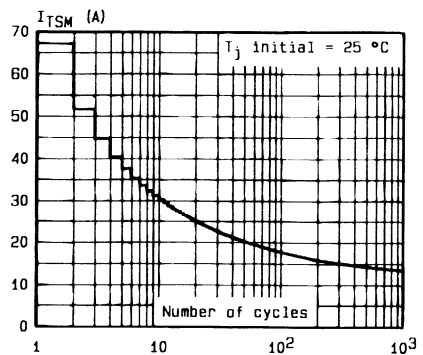

Fig.6 - Non repetitive surge peak on-state current versus number of cycles.

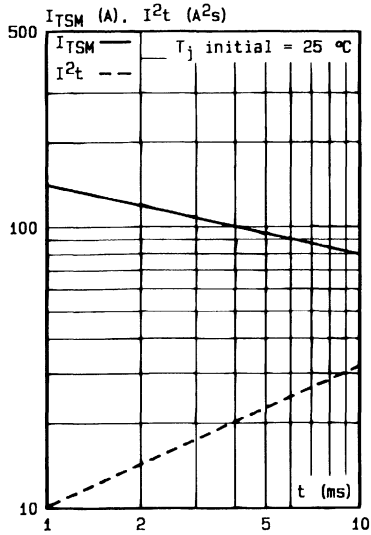

Fig.7 - Non repetitive surge peak on-state current for a sinusoidal pulse with width :  $t \leq 10$  ms, and corresponding value of  $I^2t$ .

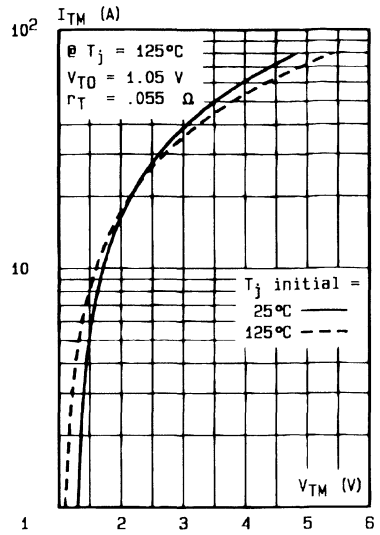
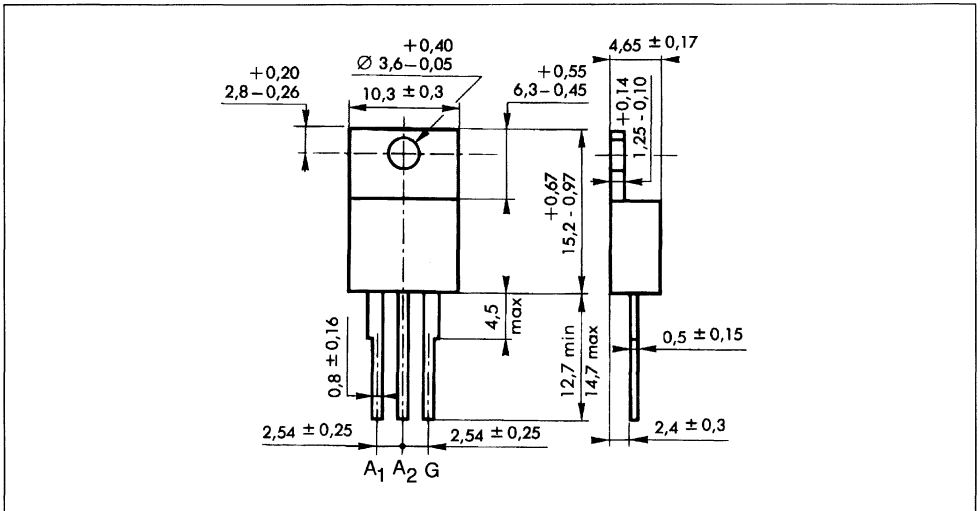

Fig.8 - On-state characteristics (maximum values).

PACKAGE MECHANICAL DATA

TO 220 AB (CB-415) Plastic



Cooling method : by conduction (method C)

Marking : type number

Weight : 2 g



**SNUBBERLESS TRIACS**

- $I_{TRMS} = 8\text{ A}$  at  $T_c = 90\text{ }^\circ\text{C}$ .
- $V_{DRM} : 200\text{ V to }800\text{ V}$ .
- $I_{GT} = 35\text{ mA}$  (QI-II-III).
- GLASS PASSIVATED CHIP.
- HIGH SURGE CURRENT :  $I_{TSM} = 80\text{ A}$ .
- HIGH COMMUTATION CAPABILITY :  
( $di/dt$ )<sub>c</sub> > 4.5 A / ms without snubber.
- INSULATING VOLTAGE : 2500  $V_{RMS}$ .

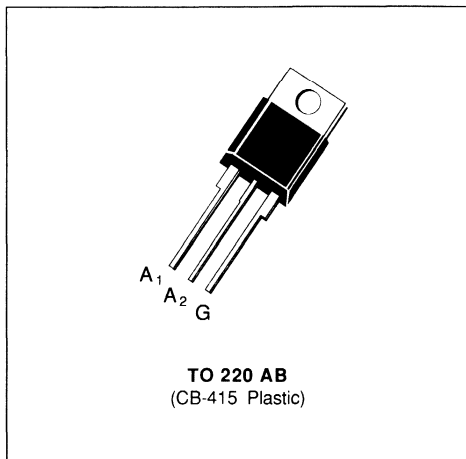
**DESCRIPTION**

New range suited for applications such as phase control and static switching on inductive or resistive load.

**ABSOLUTE RATINGS** (limiting values)

Symbol	Parameter		Value	Unit
$I_{TRMS}$	RMS on-state current (360 ° conduction angle)	$T_c = 90\text{ }^\circ\text{C}$	8	A
$I_{TSM}$	Non repetitive surge peak on-state current ( $T_j$ initial = 25 °C)	$t = 8.3\text{ ms}$	85	A
		$t = 10\text{ ms}$	80	
$I^2t$	$I^2t$ value	$t = 10\text{ ms}$	32	$\text{A}^2\text{s}$
$di/dt$	Critical rate of rise of on-state current (1)	Repetitive $F = 50\text{ Hz}$	20	$\text{A}/\mu\text{s}$
		Non Repetitive	100	
$T_{stg}$ $T_j$	Storage and operating junction temperature range		- 40, + 150 - 40, + 125	$^\circ\text{C}$ $^\circ\text{C}$

Symbol	Parameter	BTA 08-					Unit
		200 CW	400 CW	600 CW	700 CW	800 CW	
$V_{DRM}$	Repetitive peak off-state voltage (2)	± 200	± 400	± 600	± 700	± 800	V

(1) Gate supply :  $I_G = 350\text{ mA} - di_G / dt = 1\text{ A} / \mu\text{s}$ .

(2)  $T_j = 125\text{ }^\circ\text{C}$ .

**THERMAL RESISTANCES**

Symbol	Parameter	Value	Unit
$R_{th(j-a)}$	Junction to ambient	60	°C/W
$R_{th(j-c)} DC$	Junction to case for DC	4.3	°C/W
$R_{th(j-c)} AC$	Junction to case for 360 ° conduction angle (F = 50 Hz)	3.2	°C/W

**GATE CHARACTERISTICS (maximum values)**

$P_{GM} = 40 W$  (t = 10 μs)    $P_{G(AV)} = 1 W$     $I_{GM} = 4 A$  (t = 10 μs)    $V_{GM} = 16 V$  (t = 10 μs).

**ELECTRICAL CHARACTERISTICS**

Symbol	Test Conditions		Quadrants	Min.	Typ.	Max.	Unit
$I_{GT}$	$T_j = 25\text{ °C}$ Pulse duration > 20 μs	$V_D = 12\text{ V}$ $R_L = 33\text{ }\Omega$	I-II-III	1		35	mA
$V_{GT}$	$T_j = 25\text{ °C}$ Pulse duration > 20 μs	$V_D = 12\text{ V}$ $R_L = 33\text{ }\Omega$	I-II-III			1.5	V
$V_{GD}$	$T_j = 125\text{ °C}$ Pulse duration > 20 μs	$V_D = V_{DRM}$ $R_L = 3.3\text{ k}\Omega$	I-II-III	0.2			V
$I_H *$	$T_j = 25\text{ °C}$ Gate open	$I_T = 100\text{ mA}$ $R_L = 140\text{ }\Omega$				35	mA
$I_L$	$T_j = 25\text{ °C}$ Pulse duration > 20 μs	$V_D = 12\text{ V}$ $I_G = 350\text{ mA}$	I-III			50	mA
			II			80	
$V_{TM} *$	$T_j = 25\text{ °C}$	$I_{TM} = 11\text{ A}$				1.75	V
$I_{DRM} *$	$T_j = 25\text{ °C}$	$V_{DRM}$ rated Gate open				0.01	mA
	$T_j = 125\text{ °C}$					2	
$dv/dt *$	$T_j = 125\text{ °C}$ Linear slope up to 0.67 $V_{DRM}$	Gate open		250	500		V/μs
$(di/dt)_c *$	$T_j = 125\text{ °C}$ Without snubber	$V_{DRM}$ rated		4.5	9		A/ms
$t_{gt}$	$T_j = 25\text{ °C}$ $I_T = 11\text{ A}$	$di_G/dt = 1\text{ A}/\mu\text{s}$ $V_D = V_{DRM}$	$I_G = 350\text{ mA}$ I-II-III		2		μs

\* For either polarity of electrode A<sub>2</sub> voltage with reference to electrode A<sub>1</sub>.

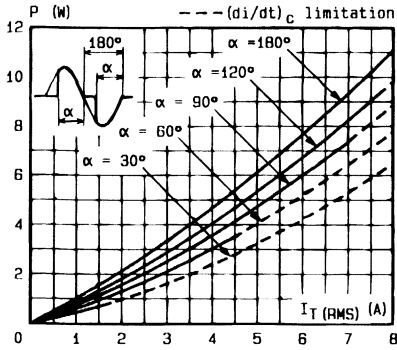

Fig.1 - Maximum mean power dissipation versus RMS on-state current ( $F = 60 \text{ Hz}$ ).

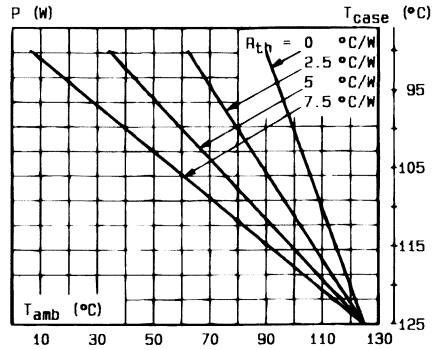

Fig.2 - Correlation between maximum mean power dissipation and maximum allowable temperatures ( $T_{amb}$  and  $T_{case}$ ) for different thermal resistances heatsink + contact.

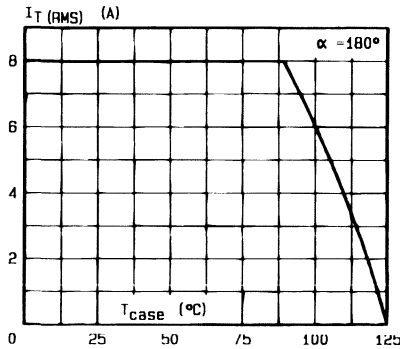

Fig.3 - RMS on-state current versus case temperature.

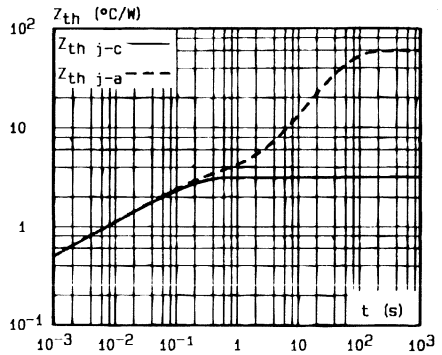

Fig.4 - Thermal transient impedance junction to case and junction to ambient versus pulse duration.

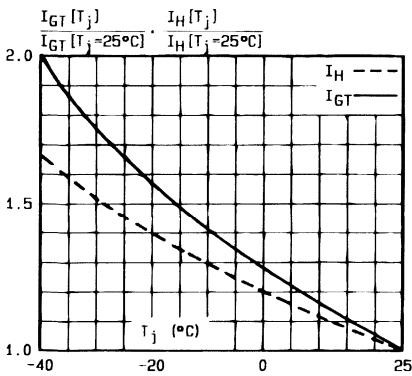

Fig.5 - Relative variation of gate trigger current and holding current versus junction temperature.

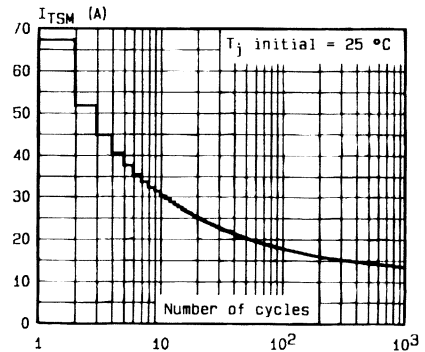

Fig.6 - Non repetitive surge peak on-state current versus number of cycles.

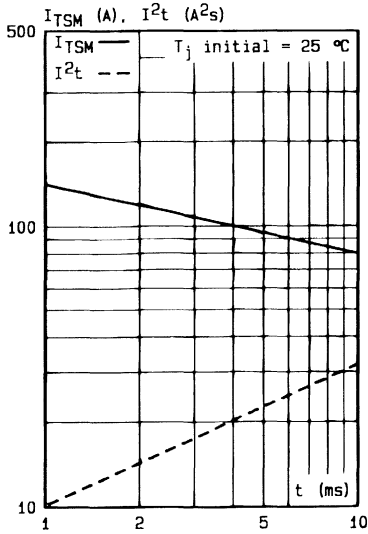

Fig.7 - Non repetitive surge peak on-state current for a sinusoidal pulse with width :  $t \leq 10$  ms, and corresponding value of  $I^2t$ .

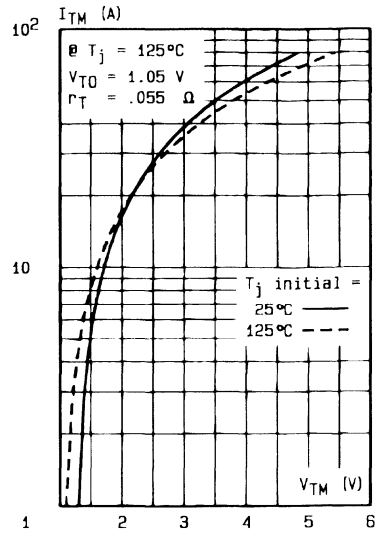
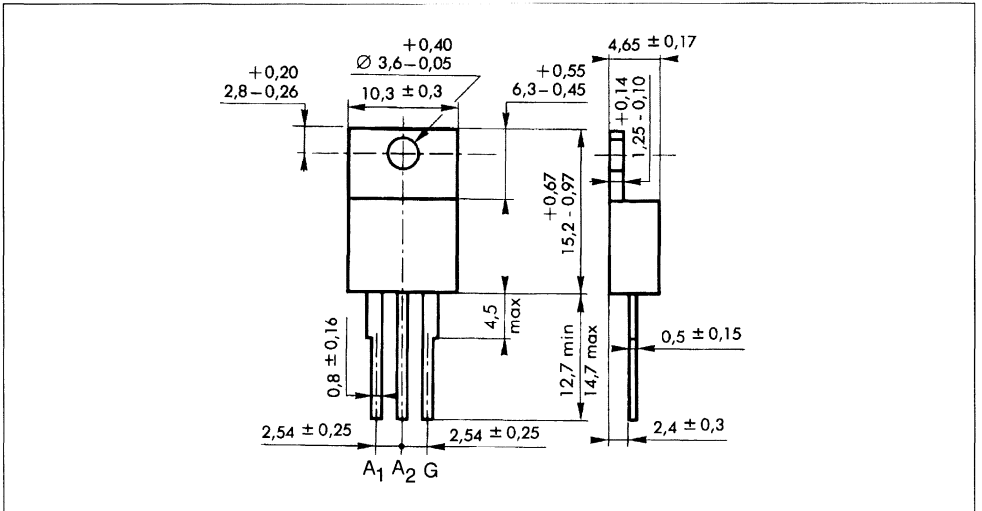

Fig.8 - On-state characteristics (maximum values).

**PACKAGE MECHANICAL DATA**

TO 220 AB (CB-415) Plastic



Cooling method : by conduction (method C)

Marking : type number

Weight : 2 g

**SNUBBERLESS TRIACS**

- $I_{TRMS} = 10\text{ A}$  at  $T_c = 90\text{ }^\circ\text{C}$ .
- $V_{DRM} : 200\text{ V}$  to  $800\text{ V}$ .
- $I_{GT} = 75\text{ mA}$  (QI-II-III).
- GLASS PASSIVATED CHIP.
- HIGH SURGE CURRENT :  $I_{TSM} = 100\text{ A}$ .
- HIGH COMMUTATION CAPABILITY :  
( $di/dt$ )<sub>c</sub> >  $12\text{ A/ms}$  without snubber.
- INSULATING VOLTAGE :  $2500\text{ V}_{RMS}$ .
- UL RECOGNIZED (E81734).

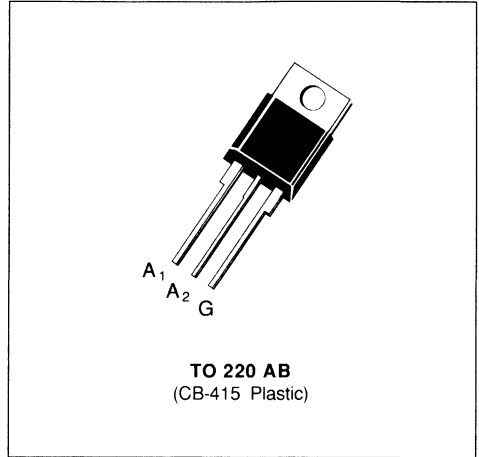
**DESCRIPTION**

New range suited for applications such as phase control and static switching on inductive or resistive load.

**ABSOLUTE RATINGS** (limiting values)

Symbol	Parameter		Value	Unit
$I_{TRMS}$	RMS on-state current (360 ° conduction angle)	$T_c = 90\text{ }^\circ\text{C}$	10	A
$I_{TSM}$	Non repetitive surge peak on-state current ( $T_j$ initial = $25\text{ }^\circ\text{C}$ )	$t = 8.3\text{ ms}$	105	A
		$t = 10\text{ ms}$	100	
$I^2 t$	$I^2 t$ value	$t = 10\text{ ms}$	50	$\text{A}^2\text{ s}$
$di/dt$	Critical rate of rise of on-state current (1)	Repetitive $F = 50\text{ Hz}$	20	A / $\mu\text{s}$
		Non Repetitive	100	
$T_{stg}$ $T_j$	Storage and operating junction temperature range		- 40, + 150 - 40, + 125	$^\circ\text{C}$ $^\circ\text{C}$

Symbol	Parameter	BTA 10-					Unit
		200 AW	400 AW	600 AW	700 AW	800 AW	
$V_{DRM}$	Repetitive peak off-state voltage (2)	$\pm 200$	$\pm 400$	$\pm 600$	$\pm 700$	$\pm 800$	V

(1) Gate supply :  $I_G = 750\text{ mA}$  -  $di_G/dt = 1\text{ A}/\mu\text{s}$ .

(2)  $T_j = 125\text{ }^\circ\text{C}$ .

**THERMAL RESISTANCES**

Symbol	Parameter	Value	Unit
$R_{th(j-a)}$	Junction to ambient	60	°C/W
$R_{th(j-c)}$ DC	Junction to case for DC	3.3	°C/W
$R_{th(j-c)}$ AC	Junction to case for 360° conduction angle (F = 50 Hz)	2.5	°C/W

**GATE CHARACTERISTICS (maximum values)**
 $P_{GM} = 40 \text{ W (} t = 10 \mu\text{s)}$     $P_{G(AV)} = 1 \text{ W}$     $I_{GM} = 4 \text{ A (} t = 10 \mu\text{s)}$     $V_{GM} = 16 \text{ V (} t = 10 \mu\text{s)}$ .

**ELECTRICAL CHARACTERISTICS**

Symbol	Test Conditions	Quadrants	Min.	Typ.	Max.	Unit
$I_{GT}$	$T_j = 25 \text{ °C}$ $V_D = 12 \text{ V}$ $R_L = 33 \Omega$ Pulse duration > 20 $\mu\text{s}$	I-II-III	2		75	mA
$V_{GT}$	$T_j = 25 \text{ °C}$ $V_D = 12 \text{ V}$ $R_L = 33 \Omega$ Pulse duration > 20 $\mu\text{s}$	I-II-III			1.5	V
$V_{GD}$	$T_j = 125 \text{ °C}$ $V_D = V_{DRM}$ $R_L = 3.3 \text{ k}\Omega$ Pulse duration > 20 $\mu\text{s}$	I-II-III	0.2			V
$I_H^*$	$T_j = 25 \text{ °C}$ $I_T = 100 \text{ mA}$ Gate open $R_L = 140 \Omega$				75	mA
$I_L$	$T_j = 25 \text{ °C}$ $V_D = 12 \text{ V}$ Pulse duration > 20 $\mu\text{s}$	I-III		75		mA
		II		150		
$V_{TM}^*$	$T_j = 25 \text{ °C}$ $I_{TM} = 14 \text{ A}$ $t_p = 10 \text{ ms}$				1.65	V
$I_{DRM}^*$	$T_j = 25 \text{ °C}$ $T_j = 125 \text{ °C}$	$V_{DRM}$ rated	Gate open		0.01	mA
					2	
$dv/dt^*$	$T_j = 125 \text{ °C}$ Gate open Linear slope up to 0.67 $V_{DRM}$		750	1000		V/ $\mu\text{s}$
$(di/dt)_c^*$	$T_j = 125 \text{ °C}$ $V_{DRM}$ rated Without snubber		12	24		A/ms
$t_{bt}$	$T_j = 25 \text{ °C}$ $di_G/dt = 3.5 \text{ A}/\mu\text{s}$ $I_T = 14 \text{ A}$ $V_D = V_{DRM}$	$I_G = 500 \text{ mA}$ I-II-III		2		$\mu\text{s}$

\* For either polarity of electrode A<sub>2</sub> voltage with reference to electrode A<sub>1</sub>.

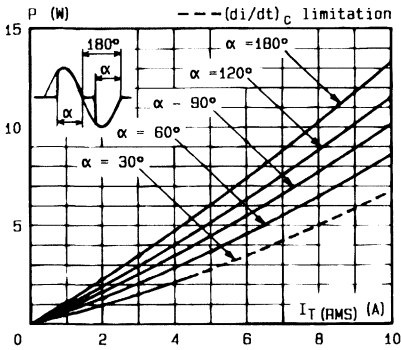

Fig. 1 - Maximum mean power dissipation versus RMS on-state current ( $f = 60$  Hz).

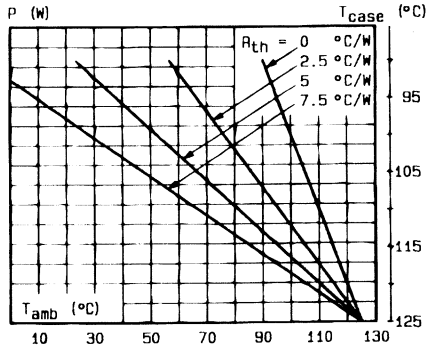

Fig. 2 - Correlation between maximum mean power dissipation and maximum allowable temperatures ( $T_{amb}$  and  $T_{case}$ ) for different thermal resistances heatsink + contact.

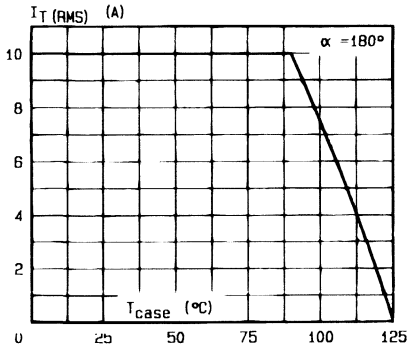

Fig. 3 - RMS on-state current versus case temperature.

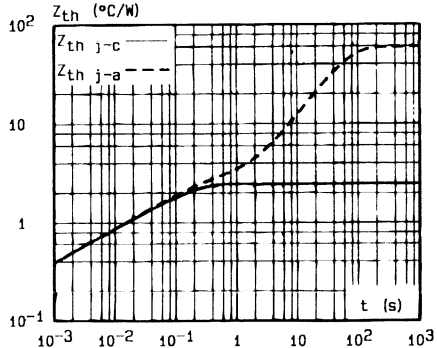

Fig. 4 - Thermal transient impedance junction to case and junction to ambient versus pulse duration.

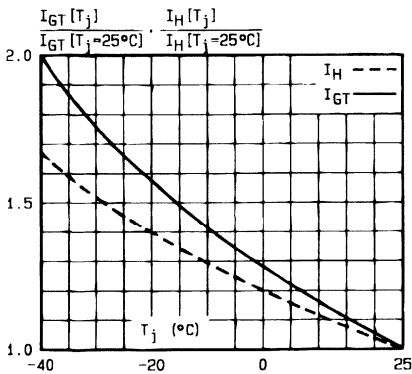

Fig. 5 - Relative variation of gate trigger current and holding current versus junction temperature.

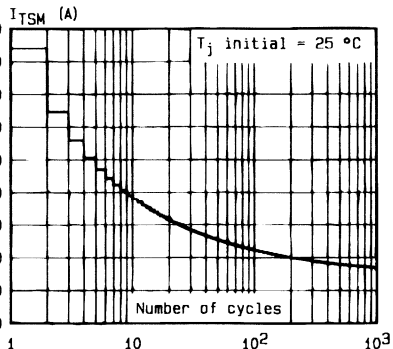

Fig. 6 - Non repetitive surge peak on-state current versus number of cycles.

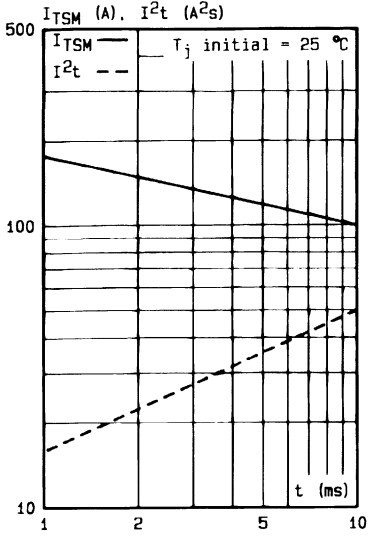

Fig.7 - Non repetitive surge peak on-state current for a sinusoidal pulse with width :  $t \leq 10$  ms, and corresponding value of  $I^2t$ .

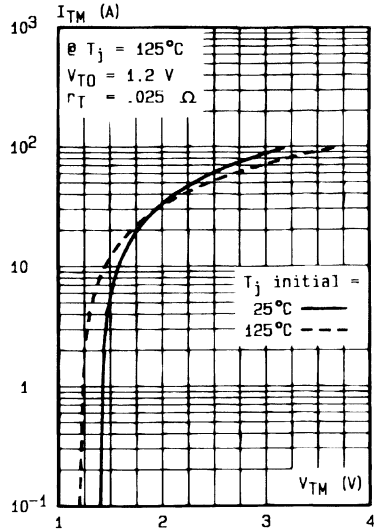
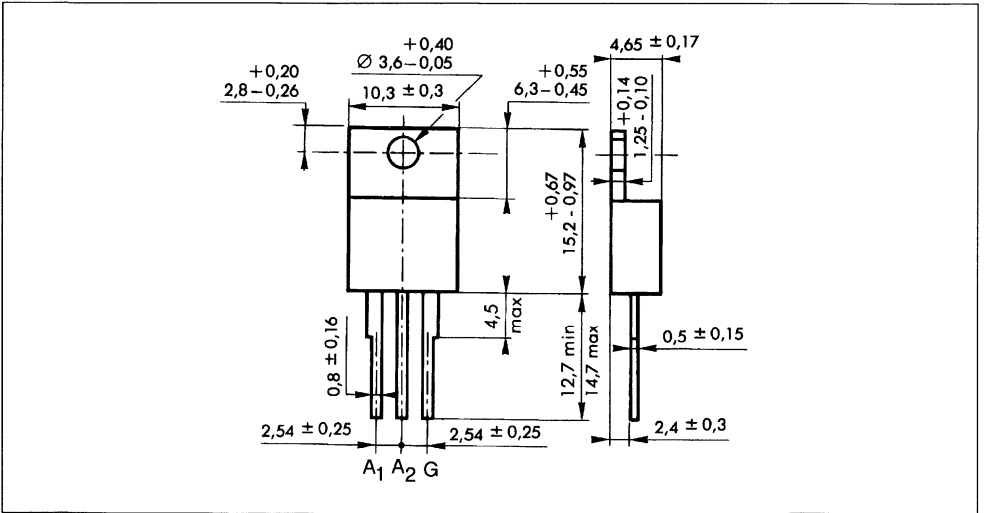

Fig.8 - On-state characteristics (maximum values).

**PACKAGE MECHANICAL DATA**

TO 220 AB (CB-415) Plastic



Cooling method : by conduction (method C)  
 Marking : type number  
 Weight : 2 g



**SNUBBERLESS TRIACS**

- $I_{TRMS} = 10 \text{ A}$  at  $T_c = 90 \text{ }^\circ\text{C}$ .
- $V_{DRM} : 200 \text{ V}$  to  $800 \text{ V}$ .
- $I_{GT} = 50 \text{ mA}$  (QI-II-III).
- GLASS PASSIVATED CHIP.
- HIGH SURGE CURRENT :  $I_{TSM} = 100 \text{ A}$ .
- HIGH COMMUTATION CAPABILITY :  
( $di/dt$ )<sub>c</sub> >  $9 \text{ A / ms}$  without snubber.
- INSULATING VOLTAGE :  $2500 \text{ V}_{RMS}$ .
- UL RECOGNIZED (E81734).

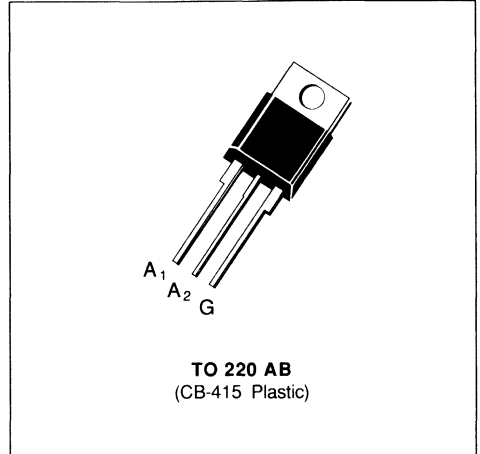
**DESCRIPTION**

New range suited for applications such as phase control and static switching on inductive or resistive load.

**ABSOLUTE RATINGS** (limiting values)

Symbol	Parameter		Value	Unit
$I_{TRMS}$	RMS on-state current (360 ° conduction angle)	$T_c = 90 \text{ }^\circ\text{C}$	10	A
$I_{TSM}$	Non repetitive surge peak on-state current ( $T_j$ initial = $25 \text{ }^\circ\text{C}$ )	$t = 8.3 \text{ ms}$	105	A
		$t = 10 \text{ ms}$	100	
$I^2 t$	$I^2 t$ value	$t = 10 \text{ ms}$	50	$\text{A}^2 \text{ s}$
$di/dt$	Critical rate of rise of on-state current (1)	Repetitive $F = 50 \text{ Hz}$	20	A / $\mu\text{s}$
		Non Repetitive	100	
$T_{stg}$ $T_j$	Storage and operating junction temperature range		- 40, + 150 - 40, + 125	$^\circ\text{C}$ $^\circ\text{C}$

Symbol	Parameter	BTA 10-					Unit
		200 BW	400 BW	600 BW	700 BW	800 BW	
$V_{DRM}$	Repetitive peak off-state voltage (2)	$\pm 200$	$\pm 400$	$\pm 600$	$\pm 700$	$\pm 800$	V

(1) Gate supply :  $I_G = 500 \text{ mA} - di_G / dt = 1 \text{ A / } \mu\text{s}$ .

(2)  $T_j = 125 \text{ }^\circ\text{C}$ .

**THERMAL RESISTANCES**

Symbol	Parameter	Value	Unit
$R_{th(j-a)}$	Junction to ambient	60	°C/W
$R_{th(j-c)} DC$	Junction to case for DC	3.3	°C/W
$R_{th(j-c)} AC$	Junction to case for 360° conduction angle (F = 50 Hz)	2.5	°C/W

**GATE CHARACTERISTICS (maximum values)**

$P_{GM} = 40 W$  (t = 10 μs)    $P_{G(AV)} = 1 W$     $I_{GM} = 4 A$  (t = 10 μs)    $V_{GM} = 16 V$  (t = 10 μs).

**ELECTRICAL CHARACTERISTICS**

Symbol	Test Conditions	Quadrants	Min.	Typ.	Max.	Unit	
$I_{GT}$	$T_j = 25\text{ °C}$ $V_D = 12 V$ $R_L = 33\ \Omega$ Pulse duration > 20 μs	I-II-III	2		50	mA	
$V_{GT}$	$T_j = 25\text{ °C}$ $V_D = 12 V$ $R_L = 33\ \Omega$ Pulse duration > 20 μs	I-II-III			1.5	V	
$V_{GD}$	$T_j = 125\text{ °C}$ $V_D = V_{DRM}$ $R_L = 3.3\ k\Omega$ Pulse duration > 20 μs	I-II-III	0.2			V	
$I_H^*$	$T_j = 25\text{ °C}$ $I_T = 100\text{ mA}$ Gate open $R_L = 140\ \Omega$				50	mA	
$I_L$	$T_j = 25\text{ °C}$ $V_D = 12 V$ $I_G = 500\text{ mA}$ Pulse duration > 20 μs	I-III		50		mA	
		II		100			
$V_{TM}^*$	$T_j = 25\text{ °C}$ $I_{TM} = 14 A$ $t_p = 10\text{ ms}$				1.65	V	
$I_{DRM}^*$	$T_j = 25\text{ °C}$ $T_j = 125\text{ °C}$	$V_{DRM}$ rated	Gate open			0.01	mA
						2	
$dv/dt^*$	$T_j = 125\text{ °C}$ Gate open Linear slope up to 0.67 $V_{DRM}$		500	750		V/μs	
$(di/dt)_c^*$	$T_j = 125\text{ °C}$ $V_{DRM}$ rated Without snubber		9	18		A/ms	
$t_{gt}$	$T_j = 25\text{ °C}$ $di_G/dt = 3.5\text{ A}/\mu s$ $I_G = 500\text{ mA}$ $I_T = 14 A$ $V_D = V_{DRM}$	I-II-III		2		μs	

\* For either polarity of electrode A<sub>2</sub> voltage with reference to electrode A<sub>1</sub>.

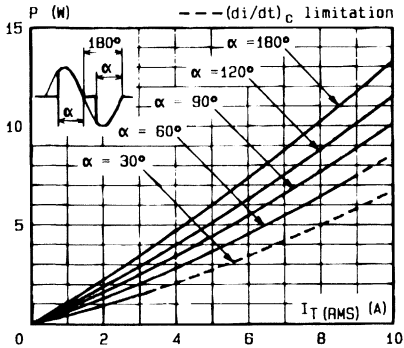

Fig.1 - Maximum mean power dissipation versus RMS on-state current ( $f = 60$  Hz).

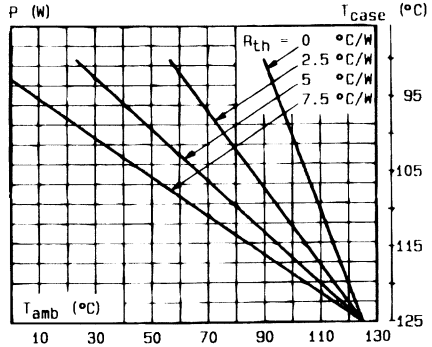

Fig.2 - Correlation between maximum mean power dissipation and maximum allowable temperatures ( $T_{amb}$  and  $T_{case}$ ) for different thermal resistances heatsink + contact.

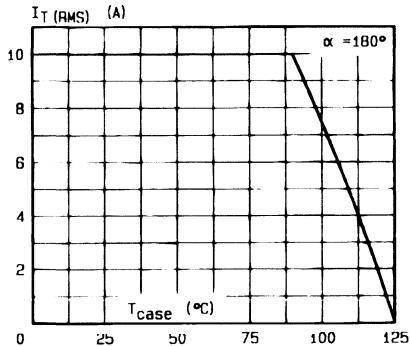

Fig.3 - RMS on-state current versus case temperature.

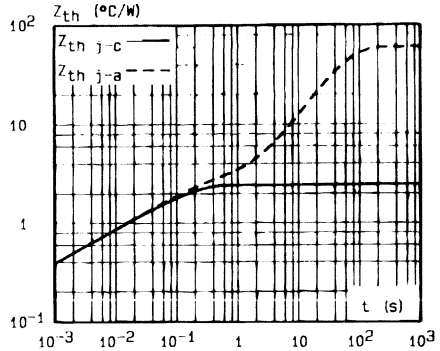

Fig.4 - Thermal transient impedance junction to case and junction to ambient versus pulse duration.

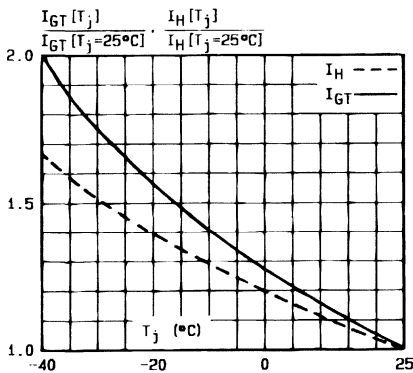

Fig.5 - Relative variation of gate trigger current and holding current versus junction temperature.

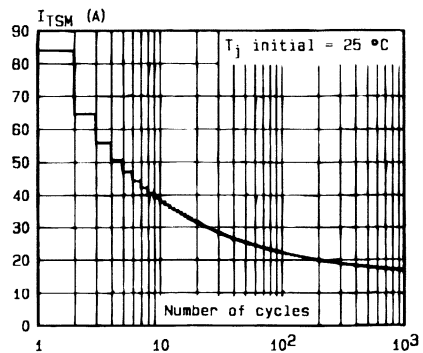

Fig.6 - Non repetitive surge peak on-state current versus number of cycles.

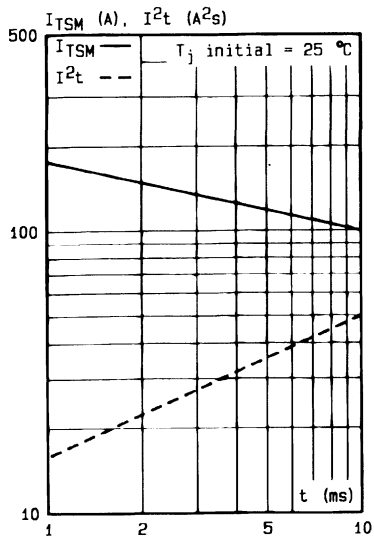

Fig.7 - Non repetitive surge peak on-state current for a sinusoidal pulse with width :  $t \leq 10$  ms, and corresponding value of  $I^2t$ .

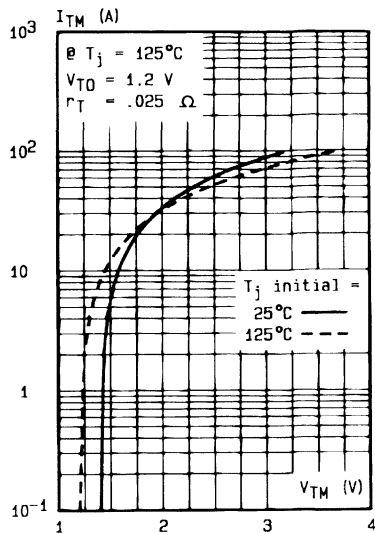
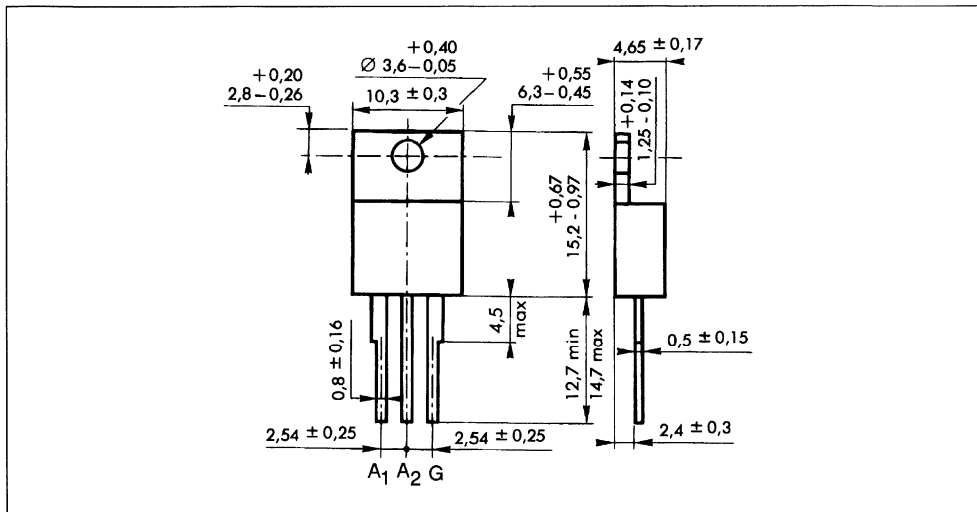

Fig.8 - On-state characteristics (maximum values).

**PACKAGE MECHANICAL DATA**

TO 220 AB (CB-415) Plastic



Cooling method : by conduction (method C)  
 Marking : type number  
 Weight : 2 g

**SNUBBERLESS TRIACS**

- $I_{TRMS} = 10\text{ A}$  at  $T_c = 90\text{ }^\circ\text{C}$ .
- $V_{DRM} : 200\text{ V to }800\text{ V}$ .
- $I_{GT} = 35\text{ mA}$  (QI-II-III).
- GLASS PASSIVATED CHIP.
- HIGH SURGE CURRENT :  $I_{TSM} = 100\text{ A}$ .
- HIGH COMMUTATION CAPABILITY :  
( $di/dt$ )<sub>c</sub> > 5.5 A / ms without snubber.
- INSULATING VOLTAGE : 2500  $V_{RMS}$ .
- UL RECOGNIZED (E81734).

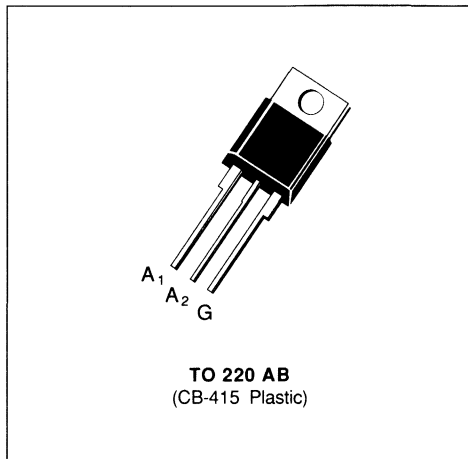
**DESCRIPTION**

New range suited for applications such as phase control and static switching on inductive or resistive load.

**ABSOLUTE RATINGS** (limiting values)

Symbol	Parameter		Value	Unit
$I_{TRMS}$	RMS on-state current (360° conduction angle)	$T_c = 90\text{ }^\circ\text{C}$	10	A
$I_{TSM}$	Non repetitive surge peak on-state current ( $T_j$ initial = 25 °C)	$t = 8.3\text{ ms}$	105	A
		$t = 10\text{ ms}$	100	
$I^2 t$	$I^2 t$ value	$t = 10\text{ ms}$	50	$\text{A}^2\text{ s}$
$di/dt$	Critical rate of rise of on-state current (1)	Repetitive $F = 50\text{ Hz}$	20	A / $\mu\text{s}$
		Non Repetitive	100	
$T_{stg}$ $T_j$	Storage and operating junction temperature range		- 40, + 150 - 40, + 125	$^\circ\text{C}$ $^\circ\text{C}$

Symbol	Parameter	BTA 10-					Unit
		200 CW	400 CW	600 CW	700 CW	800 CW	
$V_{DRM}$	Repetitive peak off-state voltage (2)	$\pm 200$	$\pm 400$	$\pm 600$	$\pm 700$	$\pm 800$	V

(1) Gate supply :  $I_G = 350\text{ mA}$  -  $di_G / dt = 1\text{ A} / \mu\text{s}$ .

(2)  $T_j = 125\text{ }^\circ\text{C}$ .

**THERMAL RESISTANCES**

Symbol	Parameter	Value	Unit
$R_{th(j-a)}$	Junction to ambient	60	°C/W
$R_{th(j-c)} DC$	Junction to case for DC	3.3	°C/W
$R_{th(j-c)} AC$	Junction to case for 360 ° conduction angle (F = 50 Hz)	2.5	°C/W

**GATE CHARACTERISTICS (maximum values)**
 $P_{GM} = 40 W$  (t = 10  $\mu s$ )    $P_{G(AV)} = 1 W$     $I_{GM} = 4 A$  (t = 10  $\mu s$ )    $V_{GM} = 16 V$  (t = 10  $\mu s$ ).

**ELECTRICAL CHARACTERISTICS**

Symbol	Test Conditions	Quadrants	Min.	Typ.	Max.	Unit
$I_{GT}$	$T_J = 25\text{ °C}$ $V_D = 12 V$ $R_L = 33\ \Omega$ Pulse duration > 20 $\mu s$	I-II-III	1		35	mA
$V_{GT}$	$T_J = 25\text{ °C}$ $V_D = 12 V$ $R_L = 33\ \Omega$ Pulse duration > 20 $\mu s$	I-II-III			1.5	V
$V_{GD}$	$T_J = 125\text{ °C}$ $V_D = V_{DRM}$ $R_L = 3.3\ k\Omega$ Pulse duration > 20 $\mu s$	I-II-III	0.2			V
$I_H^*$	$T_J = 25\text{ °C}$ $I_T = 100\text{ mA}$ Gate open $R_L = 140\ \Omega$				35	mA
$I_L$	$T_J = 25\text{ °C}$ $V_D = 12 V$ $I_G = 350\text{ mA}$ Pulse duration > 20 $\mu s$	I-III			50	mA
		II			80	
$V_{TM}^*$	$T_J = 25\text{ °C}$ $I_{TM} = 14 A$ $t_p = 10\text{ ms}$				1.65	V
$I_{DRM}^*$	$T_J = 25\text{ °C}$ $T_J = 125\text{ °C}$	$V_{DRM}$ rated Gate open			0.01	mA
					2	
$dv/dt^*$	$T_J = 125\text{ °C}$ Gate open Linear slope up to 0.67 $V_{DRM}$		250	500		V/ $\mu s$
$(di/dt)_c^*$	$T_J = 125\text{ °C}$ $V_{DRM}$ rated Without snubber		5.5	11		A/ms
$t_{gt}$	$T_J = 25\text{ °C}$ $di_G/dt = 1\text{ A}/\mu s$ $I_G = 350\text{ mA}$ $I_T = 14 A$ $V_D = V_{DRM}$	I-II-III		2		$\mu s$

\* For either polarity of electrode A<sub>2</sub> voltage with reference to electrode A<sub>1</sub>.

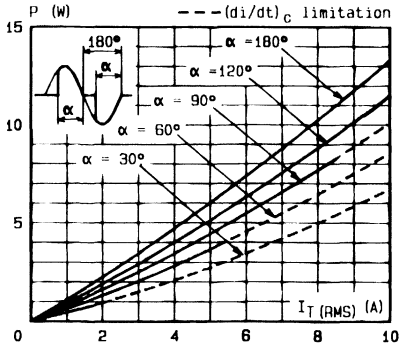

Fig. 1 - Maximum mean power dissipation versus RMS on-state current (F = 60 Hz).

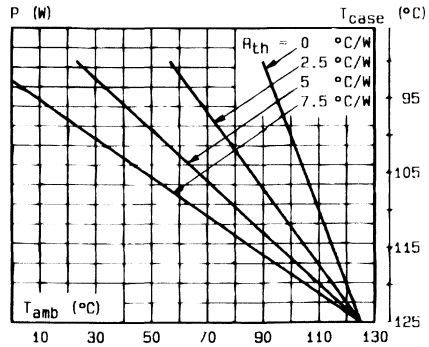

Fig. 2 - Correlation between maximum mean power dissipation and maximum allowable temperatures ( $T_{amb}$  and  $T_{case}$ ) for different thermal resistances heatsink + contact.

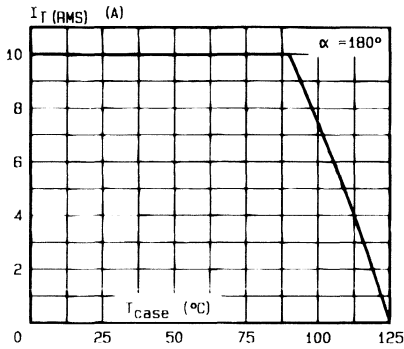

Fig. 3 - RMS on-state current versus case temperature.

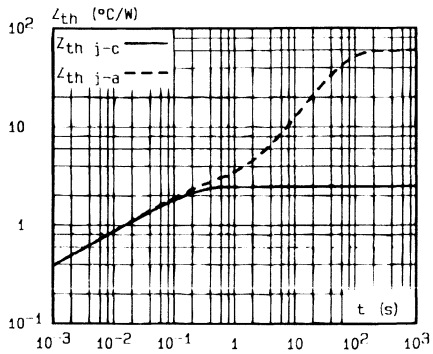

Fig. 4 - Thermal transient impedance junction to case and junction to ambient versus pulse duration.

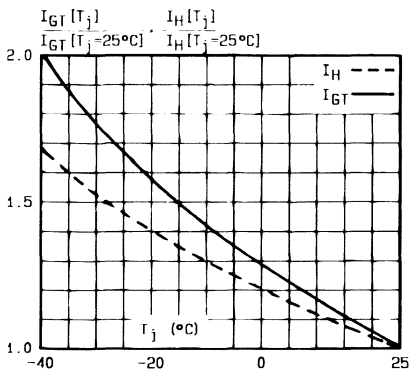

Fig. 5 - Relative variation of gate trigger current and holding current versus junction temperature.

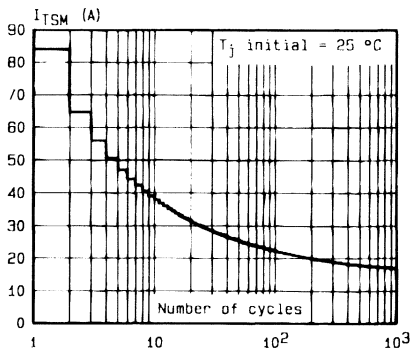

Fig. 6 - Non repetitive surge peak on state current versus number of cycles.

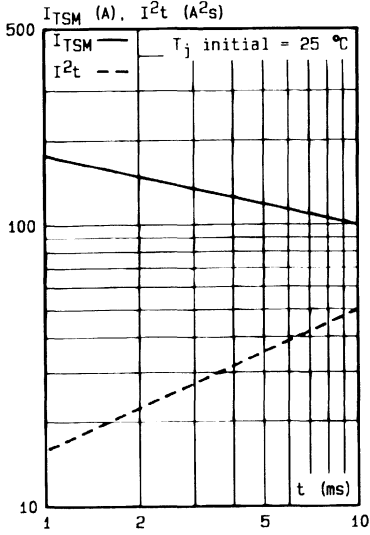

Fig.7 - Non repetitive surge peak on-state current for a sinusoidal pulse with width :  $t \leq 10$  ms, and corresponding value of  $I^2t$ .

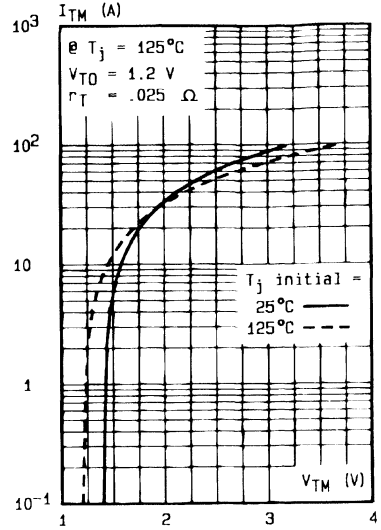
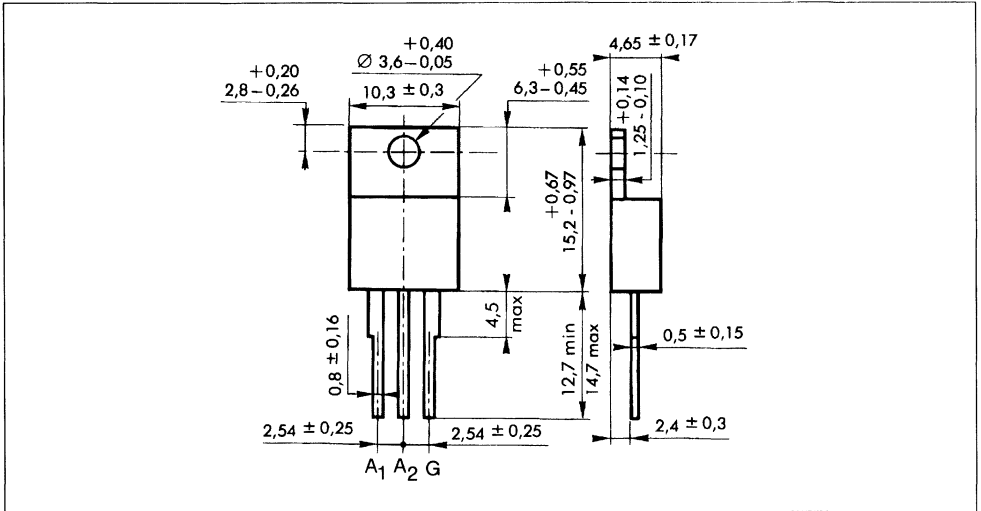

Fig.8 - On-state characteristics (maximum values).

**PACKAGE MECHANICAL DATA**

TO 220 AB (CB-415) Plastic



Cooling method : by conduction (method C)  
 Marking : type number  
 Weight : 2 g



**SNUBBERLESS TRIACS**

- $I_{TRMS} = 12\text{ A}$  at  $T_c = 85\text{ }^\circ\text{C}$ .
- $V_{DRM} : 200\text{ V}$  to  $800\text{ V}$ .
- $I_{GT} = 75\text{ mA}$  (QI-II-III).
- GLASS PASSIVATED CHIP.
- HIGH SURGE CURRENT :  $I_{TSM} = 120\text{ A}$ .
- HIGH COMMUTATION CAPABILITY :  
 $(di/dt)_c > 16\text{ A/ms}$  without snubber.
- INSULATING VOLTAGE :  $2500\text{ V}_{RMS}$ .
- UL RECOGNIZED (E81734).

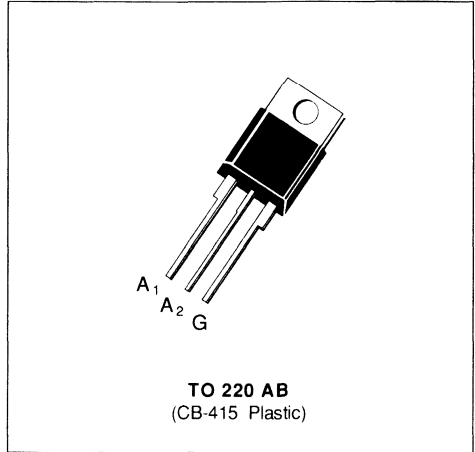
**DESCRIPTION**

New range suited for applications such as phase control and static switching on inductive or resistive load.

**ABSOLUTE RATINGS** (limiting values)

Symbol	Parameter		Value	Unit
$I_{TRMS}$	RMS on-state current (360 ° conduction angle)	$T_c = 85\text{ }^\circ\text{C}$	12	A
$I_{TSM}$	Non repetitive surge peak on-state current ( $T_j$ initial = $25\text{ }^\circ\text{C}$ )	$t = 8.3\text{ ms}$	126	A
		$t = 10\text{ ms}$	120	
$I^2 t$	$I^2 t$ value	$t = 10\text{ ms}$	72	$\text{A}^2\text{ s}$
$di/dt$	Critical rate of rise of on-state current (1)	Repetitive $F = 50\text{ Hz}$	20	A / $\mu\text{s}$
		Non Repetitive	100	
$T_{stg}$ $T_j$	Storage and operating junction temperature range		- 40, + 150 - 40, + 125	$^\circ\text{C}$ $^\circ\text{C}$

Symbol	Parameter	BTA 12-					Unit
		200 AW	400 AW	600 AW	700 AW	800 AW	
$V_{DRM}$	Repetitive peak off-state voltage (2)	$\pm 200$	$\pm 400$	$\pm 600$	$\pm 700$	$\pm 800$	V

(1) Gate supply :  $I_G = 750\text{ mA}$  –  $di_G/dt = 1\text{ A}/\mu\text{s}$ .

(2)  $T_j = 125\text{ }^\circ\text{C}$ .

**THERMAL RESISTANCES**

Symbol	Parameter	Value	Unit
$R_{th(j-a)}$	Junction to ambient	60	°C/W
$R_{th(j-c)}$ DC	Junction to case for DC	3.3	°C/W
$R_{th(j-c)}$ AC	Junction to case for 360 ° conduction angle (F = 50 Hz)	2.5	°C/W

**GATE CHARACTERISTICS (maximum values)**

$P_{GM} = 40\text{ W}$  (t = 10 μs)    $P_{G(AV)} = 1\text{ W}$     $I_{GM} = 4\text{ A}$  (t = 10 μs)    $V_{GM} = 16\text{ V}$  (t = 10 μs).

**ELECTRICAL CHARACTERISTICS**

Symbol	Test Conditions	Quadrants	Min.	Typ.	Max.	Unit
$I_{GT}$	$T_j = 25\text{ °C}$ $V_D = 12\text{ V}$ $R_L = 33\text{ }\Omega$ Pulse duration > 20 μs	I-II-III	2		75	mA
$V_{GT}$	$T_j = 25\text{ °C}$ $V_D = 12\text{ V}$ $R_L = 33\text{ }\Omega$ Pulse duration > 20 μs	I-II-III			1.5	V
$V_{GD}$	$T_j = 125\text{ °C}$ $V_D = V_{DRM}$ $R_L = 3.3\text{ k}\Omega$ Pulse duration > 20 μs	I-II-III	0.2			V
$I_H^*$	$T_j = 25\text{ °C}$ $I_T = 100\text{ mA}$ Gate open $R_L = 140\text{ }\Omega$				75	mA
$I_L$	$T_j = 25\text{ °C}$ $V_D = 12\text{ V}$ Pulse duration > 20 μs	I-III		75		mA
		II		150		
$V_{TM}^*$	$T_j = 25\text{ °C}$ $I_{TM} = 17\text{ A}$ $t_p = 10\text{ ms}$				1.6	V
$I_{DRM}^*$	$T_j = 25\text{ °C}$ $T_j = 125\text{ °C}$	$V_{DRM}$ rated Gate open			0.01	mA
					2	
$dv/dt^*$	$T_j = 125\text{ °C}$ Gate open Linear slope up to 0.67 $V_{DRM}$		750	1000		V/μs
$(di/dt)_c^*$	$T_j = 125\text{ °C}$ $V_{DRM}$ rated Without snubber		16	32		A/ms
$t_{gt}$	$T_j = 25\text{ °C}$ $di_G/dt = 3.5\text{ A}/\mu\text{s}$ $I_G = 500\text{ mA}$ $I_T = 17\text{ A}$ $V_D = V_{DRM}$	I-II-III		2		μs

\* For either polarity of electrode A<sub>2</sub> voltage with reference to electrode A<sub>1</sub>.

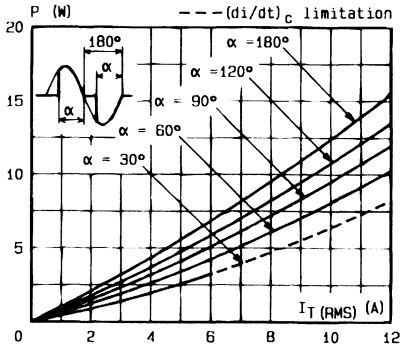

Fig. 1 - Maximum mean power dissipation versus RMS on-state current ( $F = 60$  Hz).

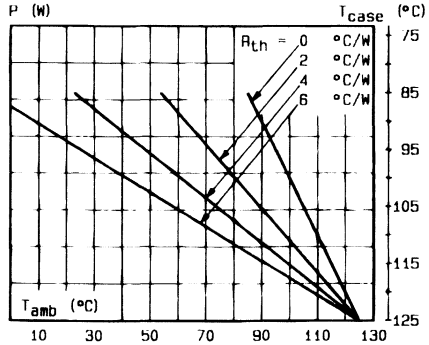

Fig. 2 - Correlation between maximum mean power dissipation and maximum allowable temperatures ( $T_{amb}$  and  $T_{case}$ ) for different thermal resistances heatsink + contact.

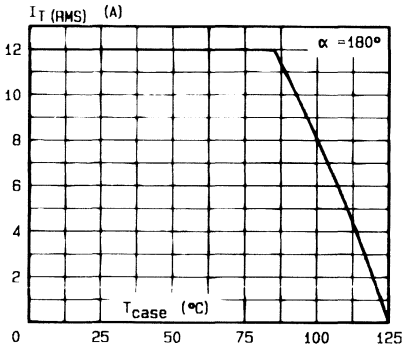

Fig. 3 - RMS on-state current versus case temperature.

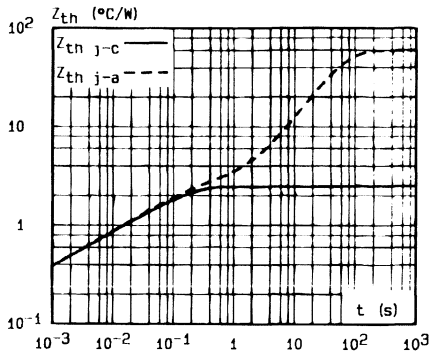

Fig. 4 - Thermal transient impedance junction to case and junction to ambient versus pulse duration.

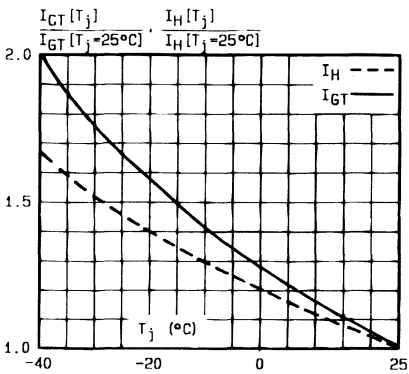

Fig. 5 - Relative variation of gate trigger current and holding current versus junction temperature.

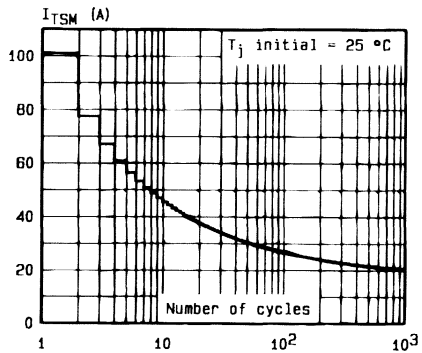

Fig. 6 - Non repetitive surge peak on-state current versus number of cycles.

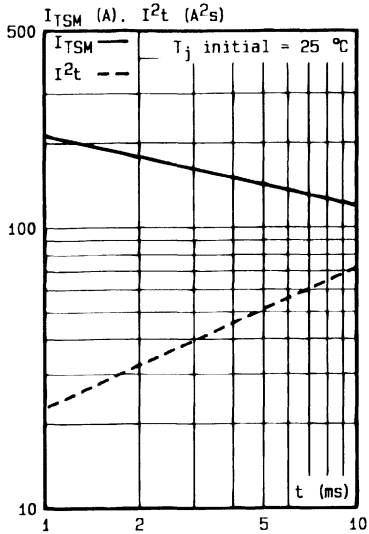

Fig.7 - Non repetitive surge peak on-state current for a sinusoidal pulse with width :  $t \leq 10$  ms, and corresponding value of  $I^2t$ .

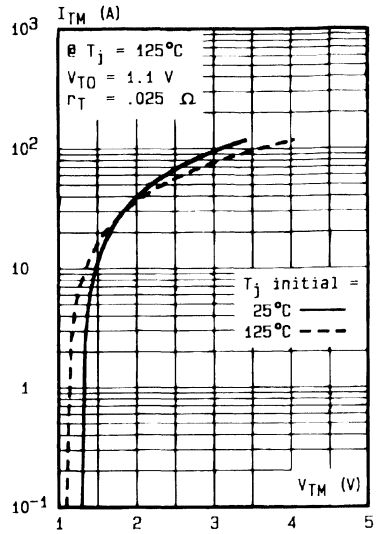
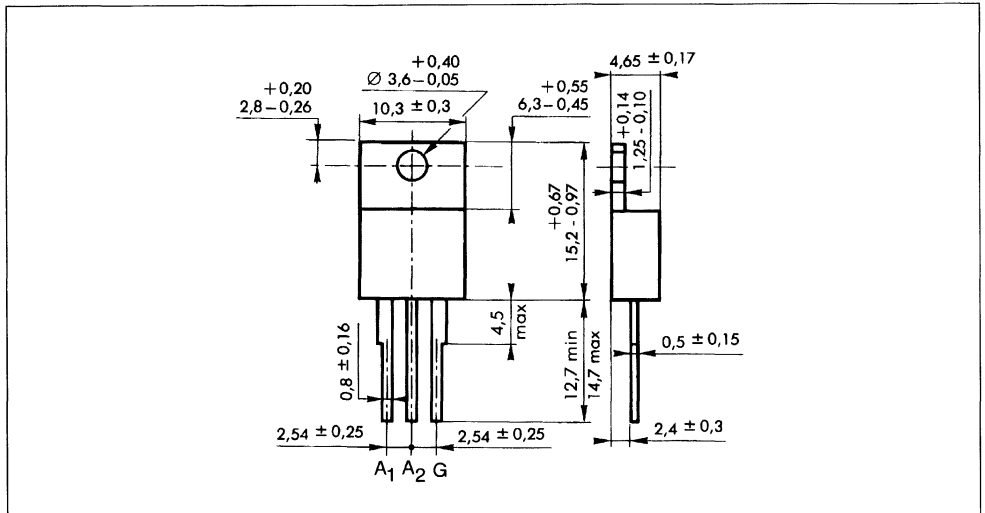

Fig.8 - On-state characteristics (maximum values).

**PACKAGE MECHANICAL DATA**

TO 220 AB (CB-415) Plastic



Cooling method : by conduction (method C)  
 Marking : type number  
 Weight : 2 g

**SNUBBERLESS TRIACS**

- $I_{TRMS} = 12\text{ A}$  at  $T_c = 85\text{ }^\circ\text{C}$ .
- $V_{DRM} : 200\text{ V to } 800\text{ V}$ .
- $I_{GT} = 50\text{ mA}$  (QI-II-III).
- GLASS PASSIVATED CHIP.
- HIGH SURGE CURRENT :  $I_{TSM} = 120\text{ A}$ .
- HIGH COMMUTATION CAPABILITY :  
( $di/dt$ )<sub>c</sub> > 12 A / ms without snubber.
- INSULATING VOLTAGE : 2500  $V_{RMS}$ .
- UL RECOGNIZED (E81734).

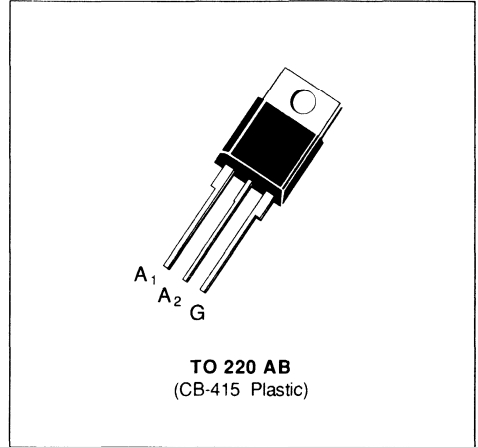
**DESCRIPTION**

New range suited for applications such as phase control and static switching on inductive or resistive load.

**ABSOLUTE RATINGS** (limiting values)

Symbol	Parameter		Value	Unit
$I_{TRMS}$	RMS on-state current (360 ° conduction angle)	$T_c = 85\text{ }^\circ\text{C}$	12	A
$I_{TSM}$	Non repetitive surge peak on-state current ( $T_j$ initial = 25 °C)	$t = 8.3\text{ ms}$	126	A
		$t = 10\text{ ms}$	120	
$I^2 t$	$I^2 t$ value	$t = 10\text{ ms}$	72	A <sup>2</sup> s
$di/dt$	Critical rate of rise of on-state current (1)	Repetitive F = 50 Hz	20	A / $\mu\text{s}$
		Non Repetitive	100	
$T_{stg}$ $T_j$	Storage and operating junction temperature range		- 40, + 150 - 40, + 125	$^\circ\text{C}$ $^\circ\text{C}$

Symbol	Parameter	BTA 12-					Unit
		200 BW	400 BW	600 BW	700 BW	800 BW	
$V_{DRM}$	Repetitive peak off-state voltage (2)	± 200	± 400	± 600	± 700	± 800	V

(1) Gate supply :  $I_G = 500\text{ mA} - di_G / dt = 1\text{ A} / \mu\text{s}$ .

(2)  $T_j = 125\text{ }^\circ\text{C}$ .

**THERMAL RESISTANCES**

Symbol	Parameter	Value	Unit
$R_{th(j-a)}$	Junction to ambient	60	°C/W
$R_{th(j-c)}$ DC	Junction to case for DC	3.3	°C/W
$R_{th(j-c)}$ AC	Junction to case for 360° conduction angle (F = 50 Hz)	2.5	°C/W

**GATE CHARACTERISTICS (maximum values)**
 $P_{GM} = 40 \text{ W}$  (t = 10  $\mu\text{s}$ )     $P_{G(AV)} = 1 \text{ W}$      $I_{GM} = 4 \text{ A}$  (t = 10  $\mu\text{s}$ )     $V_{GM} = 16 \text{ V}$  (t = 10  $\mu\text{s}$ ).

**ELECTRICAL CHARACTERISTICS**

Symbol	Test Conditions			Quadrants	Min.	Typ.	Max.	Unit
$I_{GT}$	$T_j = 25 \text{ }^\circ\text{C}$	$V_D = 12 \text{ V}$	$R_L = 33 \text{ } \Omega$	I-II-III	2		50	mA
	Pulse duration > 20 $\mu\text{s}$							
$V_{GT}$	$T_j = 25 \text{ }^\circ\text{C}$	$V_D = 12 \text{ V}$	$R_L = 33 \text{ } \Omega$	I-II-III			1.5	V
	Pulse duration > 20 $\mu\text{s}$							
$V_{GD}$	$T_j = 125 \text{ }^\circ\text{C}$	$V_D = V_{DRM}$	$R_L = 3.3 \text{ k}\Omega$	I-II-III	0.2			V
	Pulse duration > 20 $\mu\text{s}$							
$I_H^*$	$T_j = 25 \text{ }^\circ\text{C}$	$I_T = 100 \text{ mA}$					50	mA
	Gate open		$R_L = 140 \text{ } \Omega$					
$I_L$	$T_j = 25 \text{ }^\circ\text{C}$	$V_D = 12 \text{ V}$	$I_G = 500 \text{ mA}$	I-III		50		mA
				II		100		
	Pulse duration > 20 $\mu\text{s}$							
$V_{TM}^*$	$T_j = 25 \text{ }^\circ\text{C}$	$I_{TM} = 17 \text{ A}$	$t_p = 10 \text{ ms}$				1.6	V
$I_{DRM}^*$	$T_j = 25 \text{ }^\circ\text{C}$	$V_{DRM}$ rated	Gate open				0.01	mA
	$T_j = 125 \text{ }^\circ\text{C}$						2	
$dv/dt^*$	$T_j = 125 \text{ }^\circ\text{C}$	Gate open			500	750		V/ $\mu\text{s}$
	Linear slope up to 0.67 $V_{DRM}$							
$(di/dt)_c^*$	$T_j = 125 \text{ }^\circ\text{C}$	$V_{DRM}$ rated			12	24		A/ms
	Without snubber							
$t_{gt}$	$T_j = 25 \text{ }^\circ\text{C}$	$di_G/dt = 3.5 \text{ A}/\mu\text{s}$	$I_G = 500 \text{ mA}$	I-II-III		2		$\mu\text{s}$
	$I_T = 1.7 \text{ A}$	$V_D = V_{DRM}$						

\* For either polarity of electrode A<sub>2</sub> voltage with reference to electrode A<sub>1</sub>.

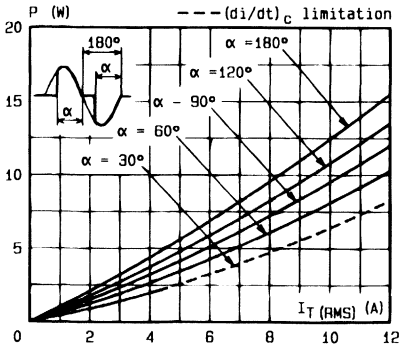

Fig.1 - Maximum mean power dissipation versus RMS on-state current ( $F = 60$  Hz).

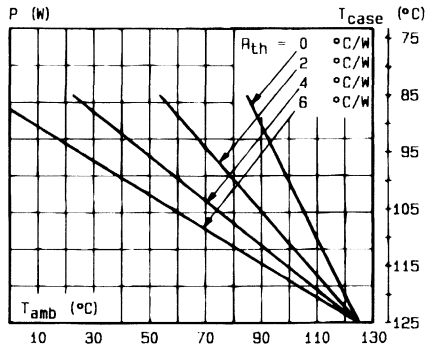

Fig.2 - Correlation between maximum mean power dissipation and maximum allowable temperatures ( $T_{amb}$  and  $T_{case}$ ) for different thermal resistances heatsink + contact.

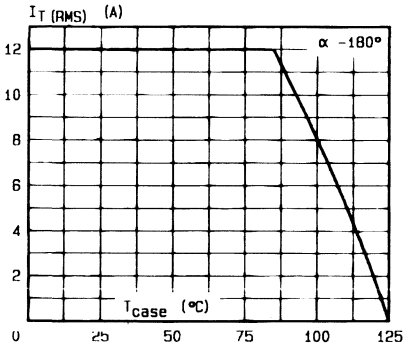

Fig.3 - RMS on-state current versus case temperature.

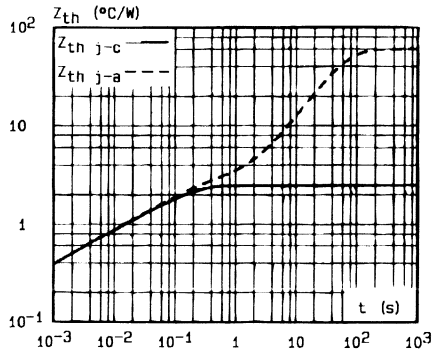

Fig.4 - Thermal transient impedance junction to case and junction to ambient versus pulse duration.

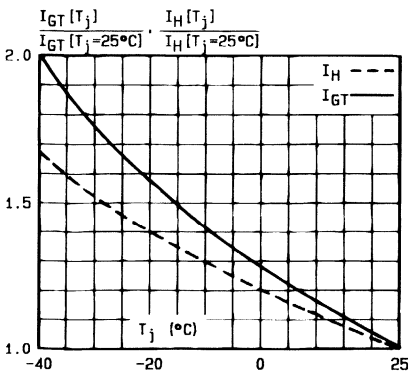

Fig.5 - Relative variation of gate trigger current and holding current versus junction temperature.

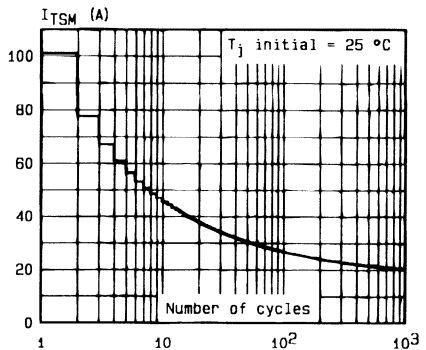

Fig.6 - Non repetitive surge peak on-state current versus number of cycles.

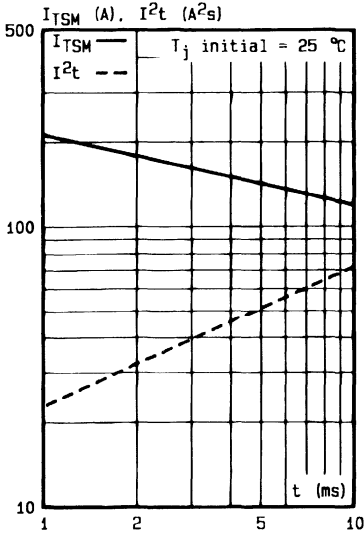

Fig.7 - Non repetitive surge peak on-state current for a sinusoidal pulse with width :  $t \leq 10$  ms, and corresponding value of  $I^2t$ .

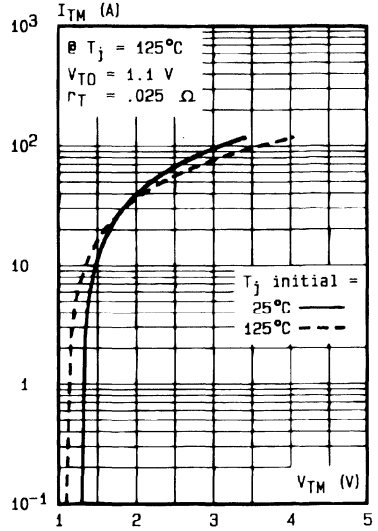
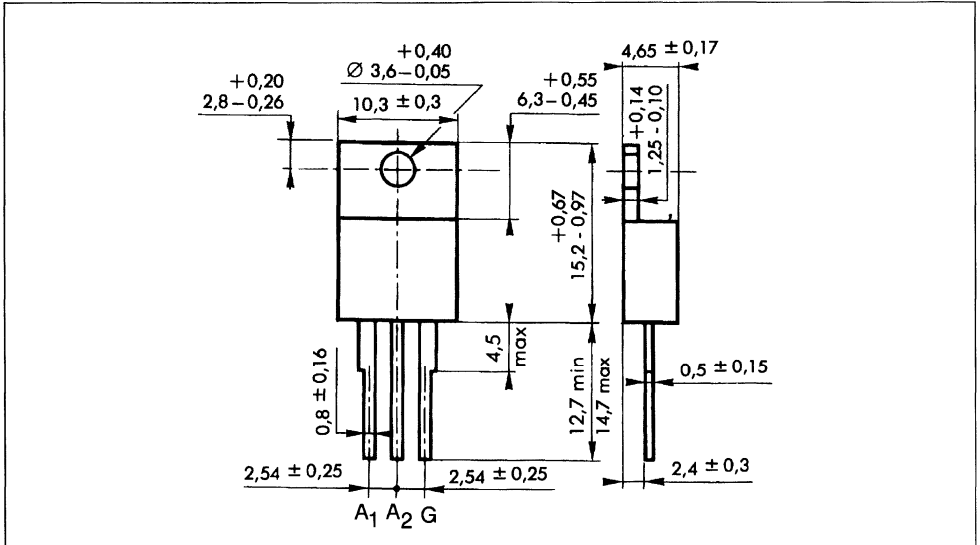

Fig.8 - On-state characteristics (maximum values).

**PACKAGE MECHANICAL DATA**

TO 220 AB (CB-415) Plastic



Cooling method : by conduction (method C)  
 Marking : type number  
 Weight : 2 g



**SNUBBERLESS TRIACS**

- $I_{TRMS} = 12\text{ A}$  at  $T_c = 85\text{ }^\circ\text{C}$ .
- $V_{DRM} : 200\text{ V}$  to  $800\text{ V}$ .
- $I_{GT} = 35\text{ mA}$  (QI-II-III).
- GLASS PASSIVATED CHIP.
- HIGH SURGE CURRENT :  $I_{TSM} = 120\text{ A}$ .
- HIGH COMMUTATION CAPABILITY :  
( $di/dt$ )<sub>c</sub> >  $6.5\text{ A/ms}$  without snubber.
- INSULATING VOLTAGE :  $2500\text{ V}_{RMS}$ .
- UL RECOGNIZED (E81734).

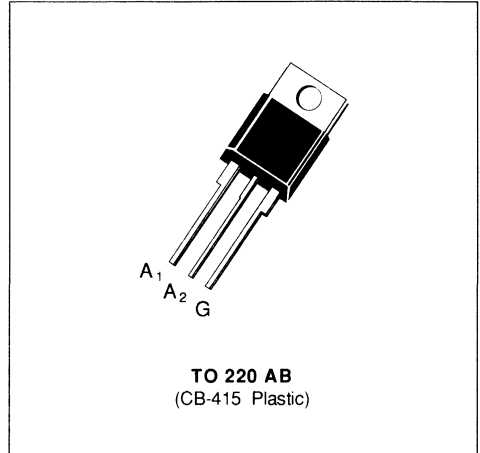
**DESCRIPTION**

New range suited for applications such as phase control and static switching on inductive or resistive load.

**ABSOLUTE RATINGS** (limiting values)

Symbol	Parameter	Value	Unit
$I_{TRMS}$	RMS on-state current (360 ° conduction angle)	$T_c = 85\text{ }^\circ\text{C}$ 12	A
$I_{TSM}$	Non repetitive surge peak on-state current ( $T_j$ initial = $25\text{ }^\circ\text{C}$ )	$t = 8.3\text{ ms}$	126
		$t = 10\text{ ms}$	120
$I^2 t$	$I^2 t$ value	$t = 10\text{ ms}$	$\text{A}^2\text{ s}$
$di/dt$	Critical rate of rise of on-state current (1)	Repetitive $F = 50\text{ Hz}$	20
		Non Repetitive	100
$T_{stg}$ $T_j$	Storage and operating junction temperature range	- 40, + 150 - 40, + 125	$^\circ\text{C}$ $^\circ\text{C}$

Symbol	Parameter	BTA 12-					Unit
		200 CW	400 CW	600 CW	700 CW	800 CW	
$V_{DRM}$	Repetitive peak off-state voltage (2)	$\pm 200$	$\pm 400$	$\pm 600$	$\pm 700$	$\pm 800$	V

(1) Gate supply :  $I_G = 350\text{ mA}$  –  $di_G / dt = 1\text{ A} / \mu\text{s}$ .

(2)  $T_j = 125\text{ }^\circ\text{C}$ .

**THERMAL RESISTANCES**

Symbol	Parameter	Value	Unit
$R_{th(j-a)}$	Junction to ambient	60	°C/W
$R_{th(j-c)} DC$	Junction to case for DC	3.3	°C/W
$R_{h(j-c)} AC$	Junction to case for 360 ° conduction angle (F = 50 Hz)	2.5	°C/W

**GATE CHARACTERISTICS (maximum values)**
 $P_{GM} = 40 \text{ W (} t = 10 \mu\text{s)}$     $P_{G(AV)} = 1 \text{ W}$     $I_{GM} = 4 \text{ A (} t = 10 \mu\text{s)}$     $V_{GM} = 16 \text{ V (} t = 10 \mu\text{s)}$ .

**ELECTRICAL CHARACTERISTICS**

Symbol	Test Conditions			Quadrants	Min.	Typ.	Max.	Unit
$I_{GT}$	$T_j = 25 \text{ °C}$	$V_D = 12 \text{ V}$ Pulse duration > 20 $\mu\text{s}$	$R_L = 33 \text{ }\Omega$	I-II-III	1		35	mA
$V_{GT}$	$T_j = 25 \text{ °C}$	$V_D = 12 \text{ V}$ Pulse duration > 20 $\mu\text{s}$	$R_L = 33 \text{ }\Omega$	I-II-III			1.5	V
$V_{GD}$	$T_j = 125 \text{ °C}$	$V_D = V_{DRM}$ Pulse duration > 20 $\mu\text{s}$	$R_L = 3.3 \text{ k}\Omega$	I-II-III	0.2			V
$I_H^*$	$T_j = 25 \text{ °C}$	Gate open $I_T = 100 \text{ mA}$ $R_L = 140 \text{ }\Omega$					35	mA
$I_L$	$T_j = 25 \text{ °C}$	$V_D = 12 \text{ V}$ Pulse duration > 20 $\mu\text{s}$	$I_G = 350 \text{ mA}$	I-III			50	mA
				II			80	
$V_{TM}^*$	$T_j = 25 \text{ °C}$	$I_{TM} = 17 \text{ A}$	$t_p = 10 \text{ ms}$				1.6	V
$V_{DRM}^*$	$T_j = 25 \text{ °C}$	$V_{DRM}$ rated	Gate open				0.01	mA
	$T_j = 125 \text{ °C}$						2	
$dv/dt^*$	$T_j = 125 \text{ °C}$	Gate open Linear slope up to 0.67 $V_{DRM}$			250	500		V/ $\mu\text{s}$
$(di/dt)_c^*$	$T_j = 125 \text{ °C}$	$V_{DRM}$ rated Without snubber			6.5	13		A/ms
$t_{gt}$	$T_j = 25 \text{ °C}$	$di_G/dt = 1 \text{ A}/\mu\text{s}$	$I_G = 350 \text{ mA}$	I-II-III		2		$\mu\text{s}$
	$I_T = 17 \text{ A}$	$V_D = V_{DRM}$						

\* For either polarity of electrode  $A_2$  voltage with reference to electrode  $A_1$ .

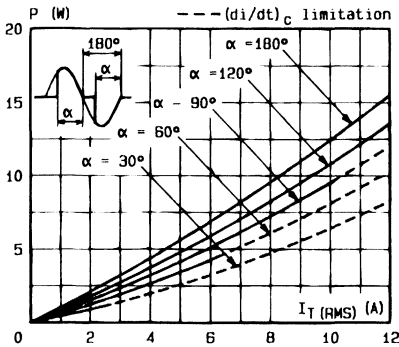

Fig. 1 - Maximum mean power dissipation versus RMS on-state current ( $F = 60$  Hz).

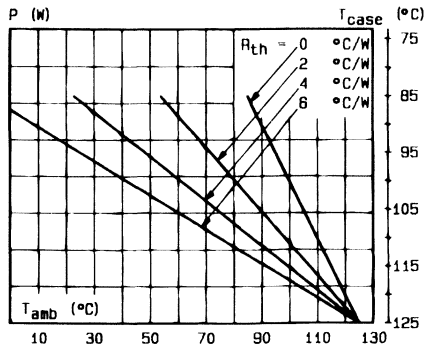

Fig. 2 - Correlation between maximum mean power dissipation and maximum allowable temperatures ( $T_{amb}$  and  $T_{case}$ ) for different thermal resistances heatsink + contact.

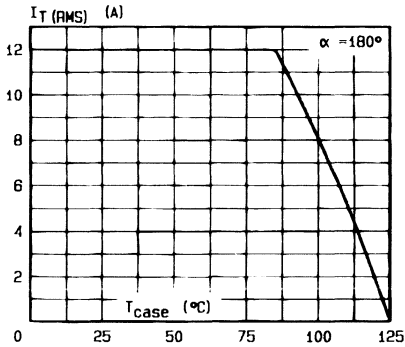

Fig. 3 - RMS on-state current versus case temperature.

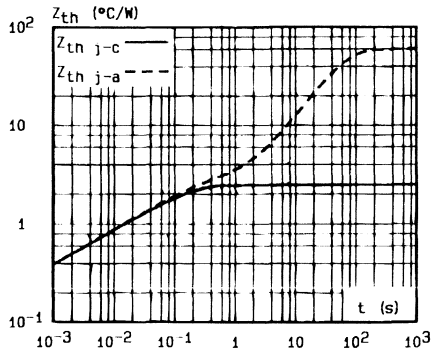

Fig. 4 - Thermal transient impedance junction to case and junction to ambient versus pulse duration.

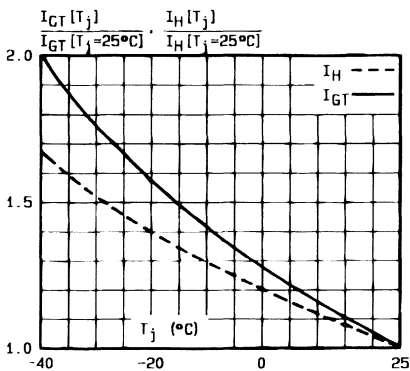

Fig. 5 - Relative variation of gate trigger current and holding current versus junction temperature.

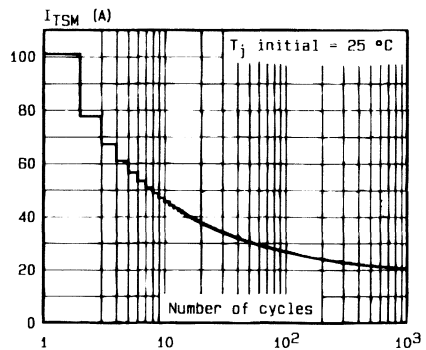

Fig. 6 - Non repetitive surge peak on-state current versus number of cycles.

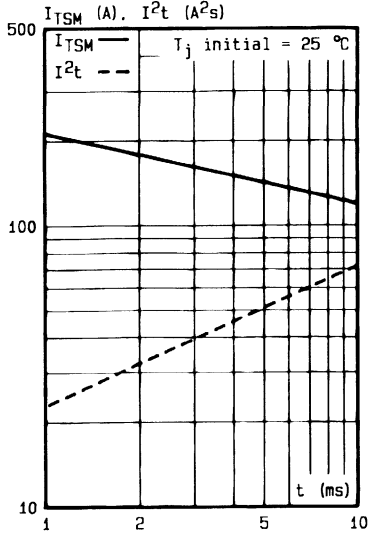

Fig.7 - Non repetitive surge peak on-state current for a sinusoidal pulse with width :  $t \leq 10$  ms, and corresponding value of  $I^2t$ .

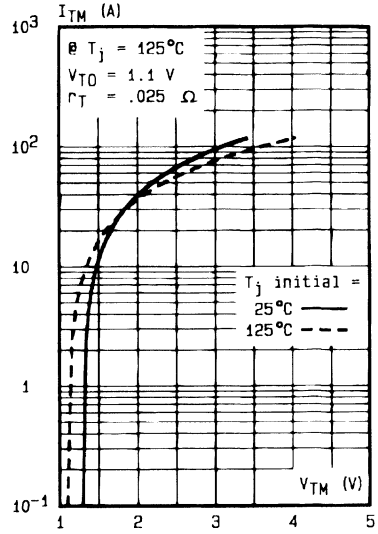
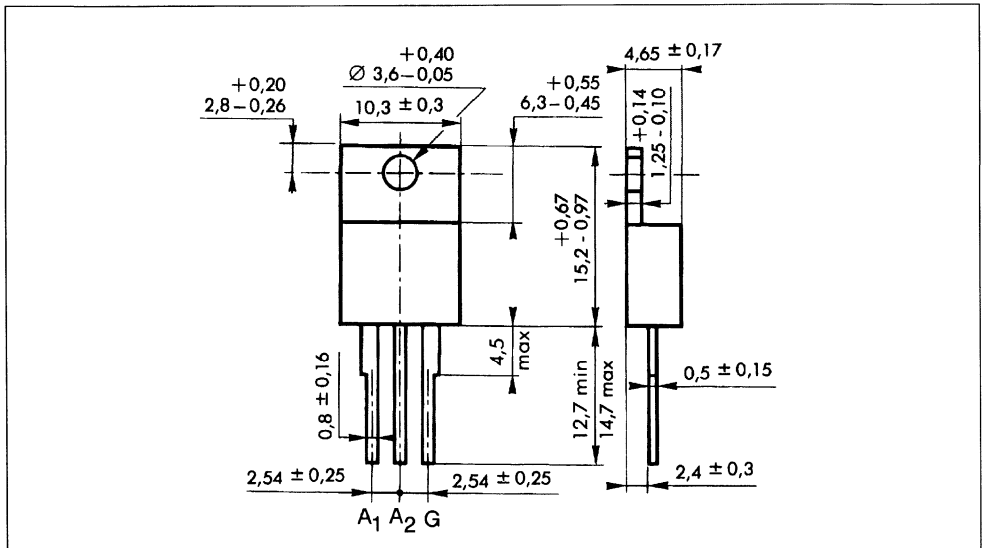

Fig.8 - On-state characteristics (maximum values).

**PACKAGE MECHANICAL DATA**

TO 220 AB (CB-415) Plastic



Cooling method : by conduction (method C)  
 Marking : type number  
 Weight : 2 g

**TRIACS**

- GLASS PASSIVATED CHIP
- INSULATING VOLTAGE : 2500 VRMS
- HIGH CAPACITOR DISCHARGE CURRENT
- UL RECOGNIZED (E81734)

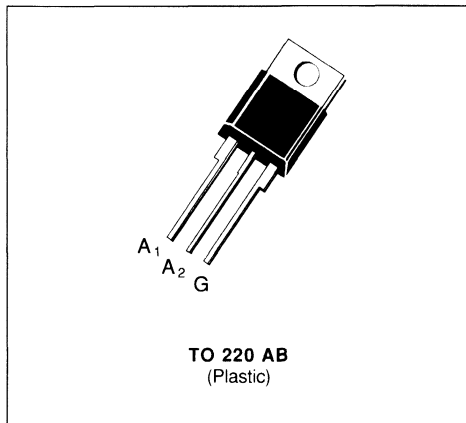
**DESCRIPTION**

Design primarily for applications such as phase control, static switching, power supply.

**ABSOLUTE RATINGS** (limiting values)

Symbol	Parameter		Value	Unit
$I_{T(RMS)}$	RMS on-state Current (360° conduction angle)	$T_C = 90^\circ C$	12	A
$I_{TSM}$	Non Repetitive Surge Peak on-state Current ( $T_j$ initial = 25 °C - Half sine wave)	$t = 8.3$ ms	157	A
		$t = 10$ ms	150	
$I^2t$	$I^2t$ Value for Fusing	$t = 10$ ms	112.5	A <sup>2</sup> s
di/dt	Critical Rate of Rise of on-state Current (1)	Repetitive F = 50 Hz	20	A/μs
		Non Repetitive	100	
$T_{stg}$ $T_j$	Storage and Operating Junction Temperature Range		- 40 to 150 - 40 to 125	°C °C

Symbol	Parameter	BTA 13-					Unit
		200B	400B	600B	700B	800B	
$V_{DRM}$	Repetitive Peak off-state Voltage (2)	200	400	600	700	800	V

(1)  $I_G = 750$  mA     $di_G/dt = 1$  A/μs

(2)  $T_j = 125^\circ C$ .

**THERMAL RESISTANCES**

Symbol	Parameter	Value	Unit
$R_{th(j-a)}$	Junction to Ambient	60	°C/W
$R_{th(j-c)}$ DC	Junction to Case for DC	3.3	°C/W
$R_{th(j-c)}$ AC	Junction to Case for 360° Conduction Angle (F = 50 Hz)	2.5	°C/W

**GATE CHARACTERISTICS** (maximum values)

$P_{GM} = 40 \text{ W}$  ( $t_p = 10 \mu\text{s}$ )       $I_{GM} = 4 \text{ A}$  ( $t_p = 10 \mu\text{s}$ )  
 $P_{G(AV)} = 1 \text{ W}$        $V_{GM} = 16 \text{ V}$  ( $t_p = 10 \mu\text{s}$ )

**ELECTRICAL CHARACTERISTICS**

Symbol	Test Conditions			Quadrants	Min.	Typ.	Max.	Unit
$I_{GT}$	$T_j = 25 \text{ }^\circ\text{C}$ Pulse Duration > 20 $\mu\text{s}$	$V_D = 12 \text{ V}$	$R_L = 33 \text{ } \Omega$	I-II-III			50	mA
				IV			75	
$V_{GT}$	$T_j = 25 \text{ }^\circ\text{C}$ Pulse Duration > 20 $\mu\text{s}$	$V_D = 12 \text{ V}$	$R_L = 33 \text{ } \Omega$	I-II-III-IV			1.5	V
$V_{GD}$	$T_j = 125 \text{ }^\circ\text{C}$	$V_D = V_{DRM}$	$R_L = 3.3 \text{ k}\Omega$	I-II-III-IV	0.2			V
$I_H^*$	$T_j = 25 \text{ }^\circ\text{C}$	$I_T = 100 \text{ mA}$	Gate Open				50	mA
$I_L$	$T_j = 25 \text{ }^\circ\text{C}$ Pulse Duration > 20 $\mu\text{s}$	$V_D = 12 \text{ V}$	$I_G = 150 \text{ mA}$	I-III-IV		50		mA
				II		100		
$V_{TM}^*$	$T_j = 25 \text{ }^\circ\text{C}$	$I_{TM} = 17 \text{ A}$	$t_p = 10 \text{ ms}$				1.4	V
$I_{DRM}^*$	$V_{DRM}$ Specified						0.01	mA
							2	
$dv/dt^*$	$T_j = 125 \text{ }^\circ\text{C}$	Gate Open	Linear Slope up to $V_D = 67\% V_{DRM}$		500			V/ $\mu\text{s}$
$(dv/dt)_c^*$	$T_C = 90 \text{ }^\circ\text{C}$ $(di/dt)_c = 5.3 \text{ A/ms}$	$V_D = V_{DRM}$	$I_T = 17 \text{ A}$		10			V/ $\mu\text{s}$
$t_{gt}$	$T_j = 25 \text{ }^\circ\text{C}$	$V_D = V_{DRM}$	$I_T = 17 \text{ A}$	I-II-III-IV		2		$\mu\text{s}$
		$I_G = 500 \text{ mA}$	$di_G/dt = 3.5 \text{ A}/\mu\text{s}$					

\* For either polarity of electrode A<sub>2</sub> voltage with reference to electrode A<sub>1</sub>.

**PACKAGE MECHANICAL DATA**

TO 220 AB Plastic

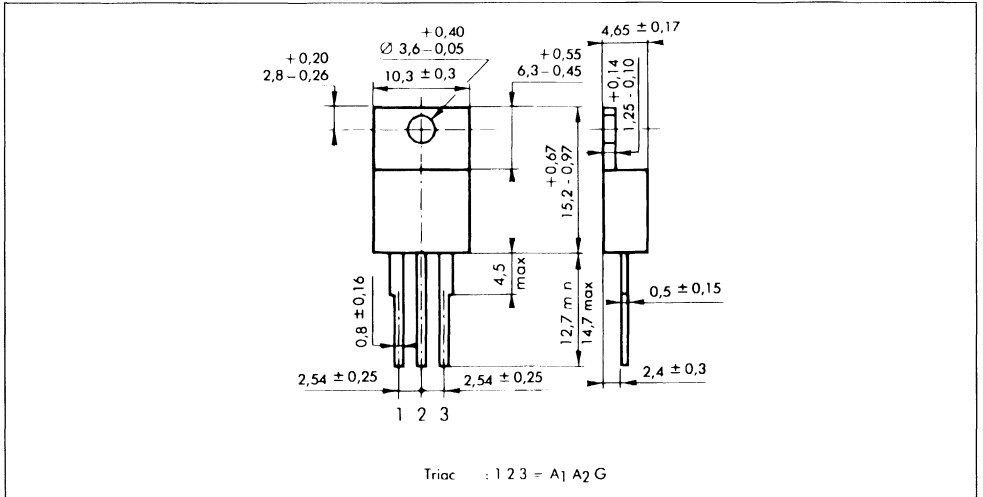

Cooling method : by conduction (method C)  
 Marking : type number  
 Weight : 2 g.

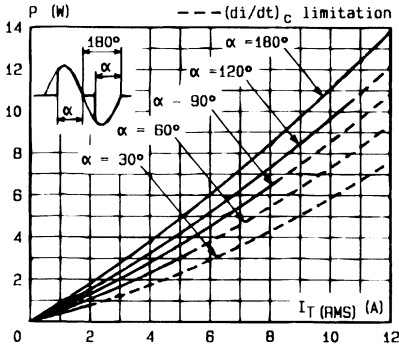

Fig. 1 - Maximum mean power dissipation versus RMS on-state current (F = 60 Hz).

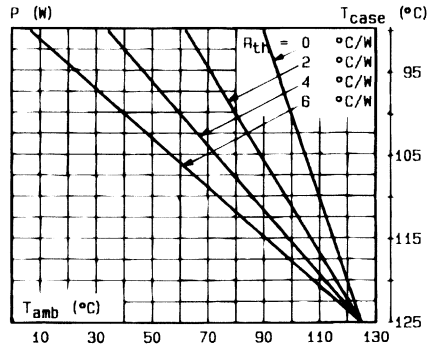

Fig. 2 - Correlation between maximum mean power dissipation and maximum allowable temperatures (T<sub>amb</sub> and T<sub>case</sub>) for different thermal resistances heatsink + contact.

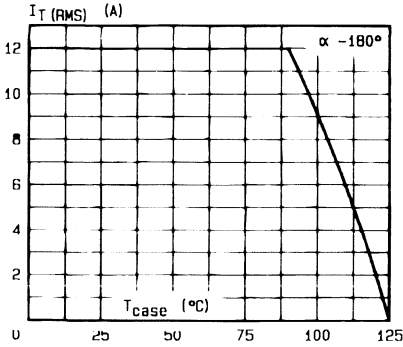

Fig. 3 - RMS on-state current versus case temperature.

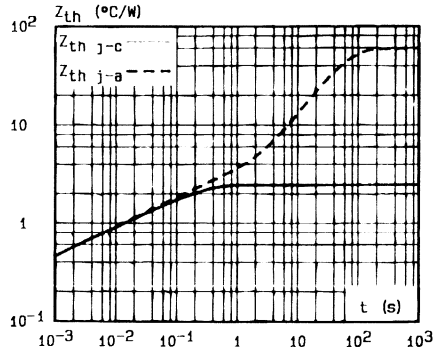

Fig. 4 - Thermal transient impedance junction to case and junction to ambient versus pulse duration.

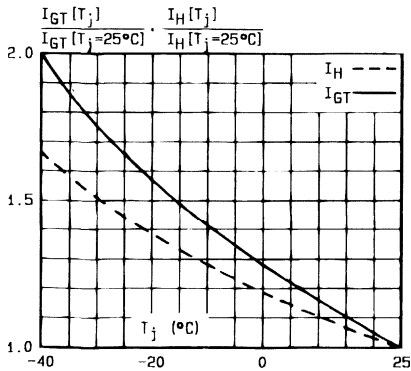

Fig. 5 - Relative variation of gate trigger current and holding current versus junction temperature.

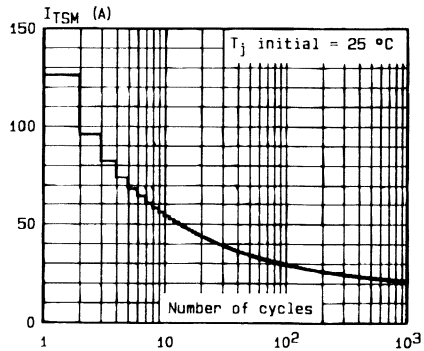

Fig. 6 - Non repetitive surge peak on-state current versus number of cycles.

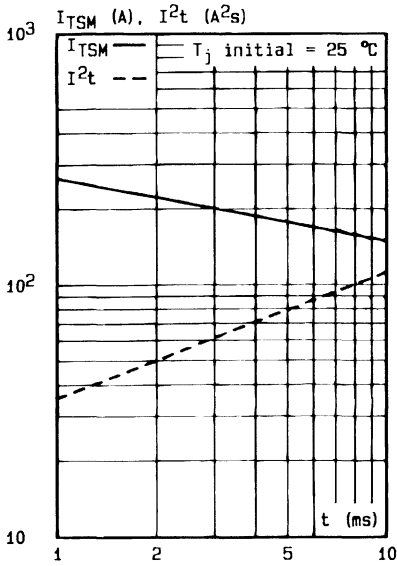

Fig.7 - Non repetitive surge peak on-state current for a sinusoidal pulse with width :  $t \leq 10$  ms, and corresponding value of  $I^2t$ .

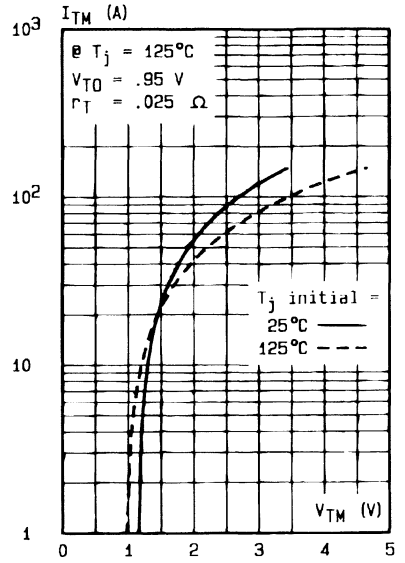
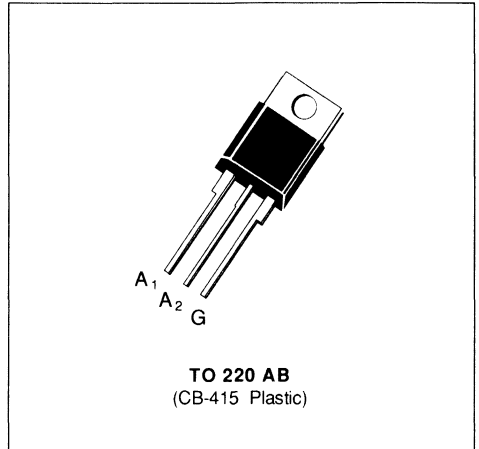

Fig.8 - Un-state characteristics (maximum values).



## SNUBBERLESS TRIACS

- $I_{TRMS} = 16\text{ A}$  at  $T_c = 80\text{ }^\circ\text{C}$ .
- $V_{DRM} : 200\text{ V}$  to  $800\text{ V}$ .
- $I_{GT} = 75\text{ mA}$  (QI-II-III).
- GLASS PASSIVATED CHIP.
- HIGH SURGE CURRENT :  $I_{TSM} = 150\text{ A}$ .
- HIGH COMMUTATION CAPABILITY :  
( $di/dt$ )<sub>c</sub> >  $21\text{ A/ms}$  without snubber.
- INSULATING VOLTAGE :  $2500\text{ V}_{RMS}$ .
- UL RECOGNIZED (E81734) .



### DESCRIPTION

New range suited for applications such as phase control and static switching on inductive or resistive load.

### ABSOLUTE RATINGS (limiting values)

Symbol	Parameter		Value	Unit
$I_{TRMS}$	RMS on-state current (360 ° conduction angle)	$T_c = 80\text{ }^\circ\text{C}$	16	A
$I_{TSM}$	Non repetitive surge peak on-state current ( $T_j$ initial = $25\text{ }^\circ\text{C}$ )	$t = 8.3\text{ ms}$	157	A
		$t = 10\text{ ms}$	150	
$I^2t$	$I^2t$ value	$t = 10\text{ ms}$	112	$\text{A}^2\text{s}$
$di/dt$	Critical rate of rise of on-state current (1)	Repetitive $F = 50\text{ Hz}$	20	$\text{A}/\mu\text{s}$
		Non Repetitive	100	
$T_{stg}$ $T_j$	Storage and operating junction temperature range		- 40, + 150 - 40, + 125	$^\circ\text{C}$ $^\circ\text{C}$

Symbol	Parameter	BTA 16-					Unit
		200 AW	400 AW	600 AW	700 AW	800 AW	
$V_{DRM}$	Repetitive peak off-state voltage (2)	$\pm 200$	$\pm 400$	$\pm 600$	$\pm 700$	$\pm 800$	V

(1) Gate supply :  $I_G = 750\text{ mA}$  –  $di_G / dt = 1\text{ A}/\mu\text{s}$ .

(2)  $T_j = 125\text{ }^\circ\text{C}$ .

**THERMAL RESISTANCES**

Symbol	Parameter	Value	Unit
$R_{th(j-a)}$	Junction to ambient	60	°C/W
$R_{th(j-c)}$ DC	Junction to case for DC	3.1	°C/W
$R_{th(j-c)}$ AC	Junction to case for 360 ° conduction angle (F = 50 Hz)	2.3	°C/W

**GATE CHARACTERISTICS (maximum values)**

$P_{GM} = 40 \text{ W}$  (t = 10  $\mu\text{s}$ )    $P_{G(AV)} = 1 \text{ W}$     $I_{GM} = 4 \text{ A}$  (t = 10  $\mu\text{s}$ )    $V_{GM} = 16 \text{ V}$  (t = 10  $\mu\text{s}$ ).

**ELECTRICAL CHARACTERISTICS**

Symbol	Test Conditions	Quadrants	Min.	Typ.	Max.	Unit
$I_{GT}$	$T_j = 25 \text{ }^\circ\text{C}$ $V_D = 12 \text{ V}$ Pulse duration > 20 $\mu\text{s}$ $R_L = 33 \text{ }\Omega$	I-II-III	2		75	mA
$V_{GT}$	$T_j = 25 \text{ }^\circ\text{C}$ $V_D = 12 \text{ V}$ Pulse duration > 20 $\mu\text{s}$ $R_L = 33 \text{ }\Omega$	I-II-III			1.5	V
$V_{GD}$	$T_j = 125 \text{ }^\circ\text{C}$ $V_D = V_{DRM}$ Pulse duration > 20 $\mu\text{s}$ $R_L = 3.3 \text{ k}\Omega$	I-II-III	0.2			V
$I_H^*$	$T_j = 25 \text{ }^\circ\text{C}$ $I_T = 100 \text{ mA}$ Gate open $R_L = 140 \text{ }\Omega$				75	mA
$I_L$	$T_j = 25 \text{ }^\circ\text{C}$ $V_D = 12 \text{ V}$ Pulse duration > 20 $\mu\text{s}$ $I_G = 500 \text{ mA}$	I-III		75		mA
		II		150		
$V_{TM}^*$	$T_j = 25 \text{ }^\circ\text{C}$ $I_{TM} = 22.5 \text{ A}$ $t_p = 10 \text{ ms}$				1.5	V
$I_{DRM}^*$	$T_j = 25 \text{ }^\circ\text{C}$ $T_j = 125 \text{ }^\circ\text{C}$	$V_{DRM}$ rated Gate open			0.01	mA
					2	
$dv/dt^*$	$T_j = 125 \text{ }^\circ\text{C}$ Gate open Linear slope up to 0.67 $V_{DRM}$		750	1000		V/ $\mu\text{s}$
$(di/dt)_c^*$	$T_j = 125 \text{ }^\circ\text{C}$ $V_{DRM}$ rated Without snubber		21	42		A/ms
$t_{gt}$	$T_j = 25 \text{ }^\circ\text{C}$ $di_G/dt = 3.5 \text{ A}/\mu\text{s}$ $I_T = 22.5 \text{ A}$ $V_D = V_{DRM}$ $I_G = 500 \text{ mA}$	I-II-III		2		$\mu\text{s}$

\* For either polarity of electrode A<sub>2</sub> voltage with reference to electrode A<sub>1</sub>.

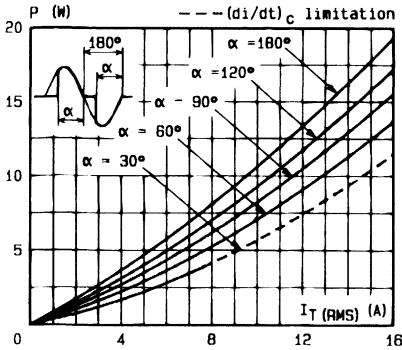

Fig. 1 - Maximum mean power dissipation versus RMS on-state current ( $F = 60$  Hz).

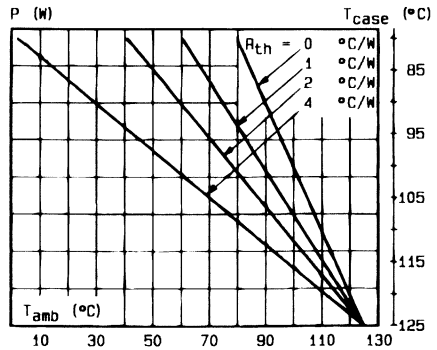

Fig. 2 - Correlation between maximum mean power dissipation and maximum allowable temperatures ( $T_{amb}$  and  $T_{case}$ ) for different thermal resistances heatsink + contact.

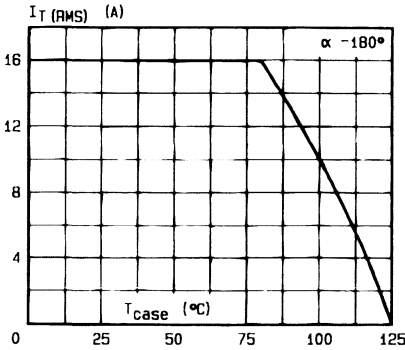

Fig. 3 - RMS on-state current versus case temperature.

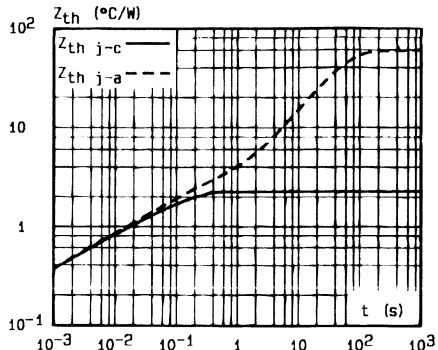

Fig. 4 - Thermal transient impedance junction to case and junction to ambient versus pulse duration.

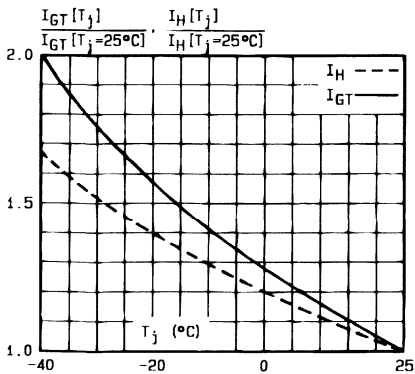

Fig. 5 - Relative variation of gate trigger current and holding current versus junction temperature.

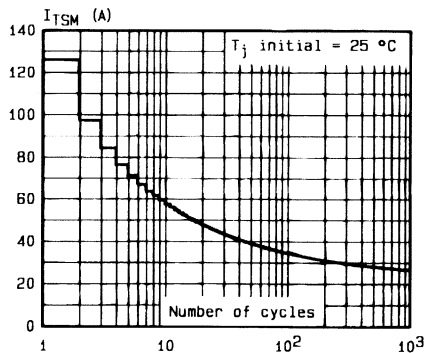

Fig. 6 - Non repetitive surge peak on-state current versus number of cycles.

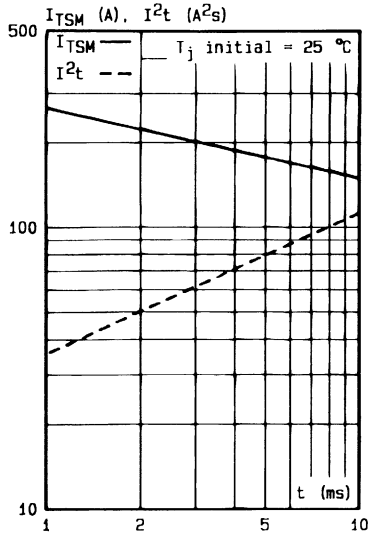

Fig.7 - Non repetitive surge peak on-state current for a sinusoidal pulse with width :  $t \leq 10$  ms, and corresponding value of  $I^2t$ .

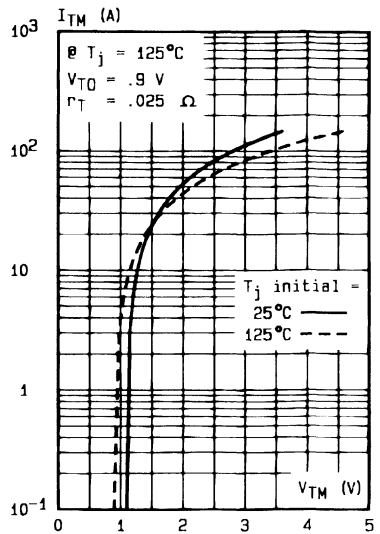
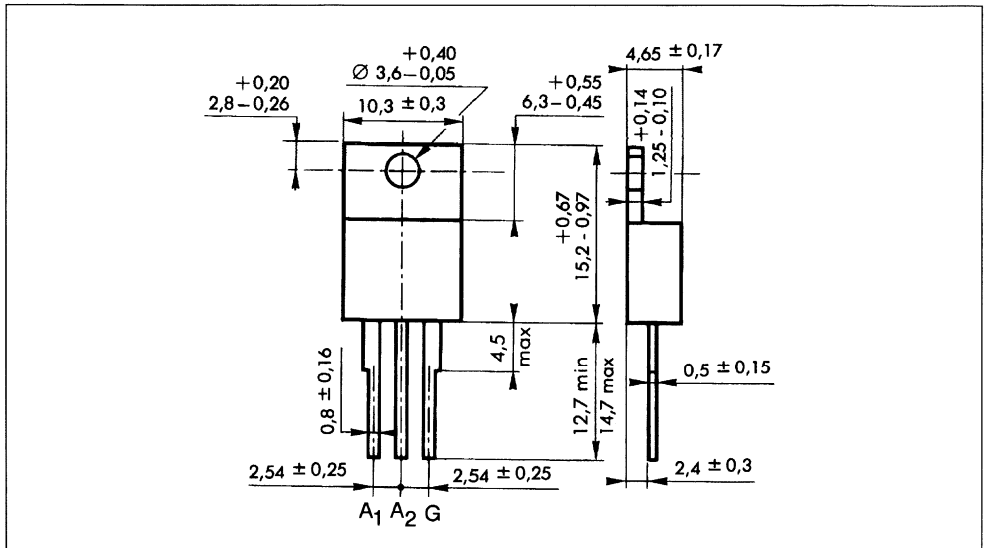

Fig.8 - On-state characteristics (maximum values).

**PACKAGE MECHANICAL DATA**

TO 220 AB (CB-415) Plastic



Cooling method : by conduction (method C)  
 Marking : type number  
 Weight : 2 g

## TRIACS

- GLASS PASSIVATED CHIP
- EXCELLENT  $(dv/dt)_c > 10 \text{ V}/\mu\text{s}$
- $I_{GT}$  SPECIFIED IN FOUR QUADRANTS
- INSULATING VOLTAGE  $2500 \text{ V}_{\text{RMS}}$
- UL RECOGNIZED (E81734)

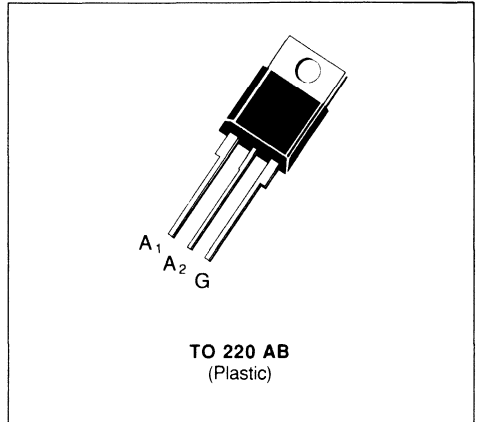

### DESCRIPTION

New range suited for applications such as phase control and static switching.

### ABSOLUTE RATINGS (limiting values)

Symbol	Parameter		Value	Unit
$I_{T(\text{RMS})}$	RMS on state Current (360° conduction angle)	$T_C = 80^\circ\text{C}$	16	A
$I_{\text{TSM}}$	Non Repetitive Surge Peak on-state Current ( $T_j$ initial = $25^\circ\text{C}$ - Half sine wave)	$t = 8.3 \text{ ms}$	170	A
		$t = 10 \text{ ms}$	160	
$I^2t$	$I^2t$ Value for Fusing	$t = 10 \text{ ms}$	128	$\text{A}^2\text{s}$
$di/dt$	Critical Rate of Rise of on-state Current (1)	Repetitive $F = 50 \text{ Hz}$	10	$\text{A}/\mu\text{s}$
		Non Repetitive	50	
$T_{\text{stg}}$ $T_j$	Storage and Operating Junction Temperature Range		- 40 to 150	$^\circ\text{C}$
			- 40 to 125	$^\circ\text{C}$

Symbol	Parameter	BTA 16-					Unit
		200B	400B	600B	700B	800B	
$V_{\text{DRM}}$	Repetitive Peak off-state Voltage (2)	200	400	600	700	800	V

(1)  $I_G = 1 \text{ A}$   $di/dt = 1 \text{ A}/\mu\text{s}$

(2)  $T_j = 125^\circ\text{C}$ .

### THERMAL RESISTANCES

Symbol	Parameter	Value	Unit
$R_{\text{th (j-a)}}$	Junction to Ambient	60	$^\circ\text{C}/\text{W}$
$R_{\text{th (j-c) DC}}$	Junction to Case for DC	3.33	$^\circ\text{C}/\text{W}$
$R_{\text{th (j-c) AC}}$	Junction to Case for 360° Conduction Angle ( $F = 50 \text{ Hz}$ )	2.5	$^\circ\text{C}/\text{W}$



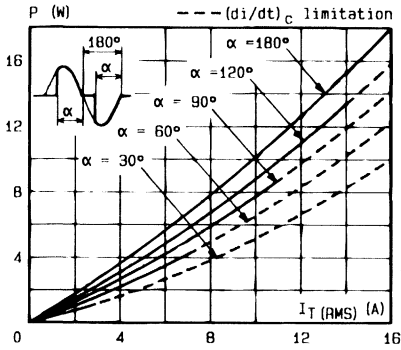

Fig. 1 - Maximum mean power dissipation versus RMS on-state current (F = 60 Hz).

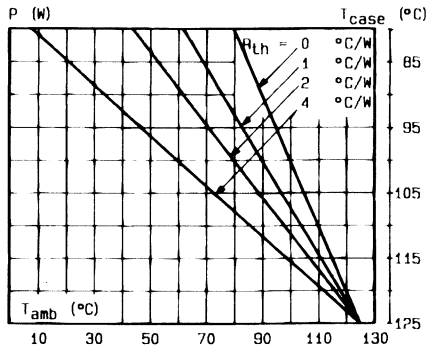

Fig. 2 - Correlation between maximum mean power dissipation and maximum allowable temperatures ( $T_{amb}$  and  $T_{case}$ ) for different thermal resistances heatsink + contact.

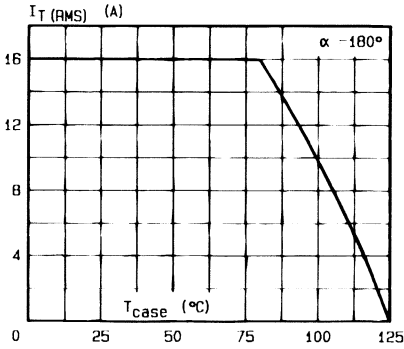

Fig. 3 - RMS on-state current versus case temperature.

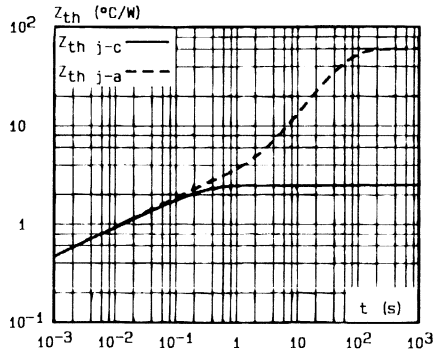

Fig. 4 - Thermal transient impedance junction to case and junction to ambient versus pulse duration.

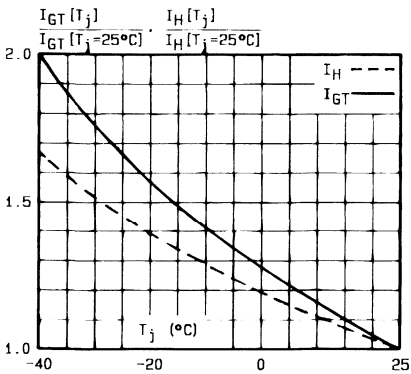

Fig. 5 - Relative variation of gate trigger current and holding current versus junction temperature.

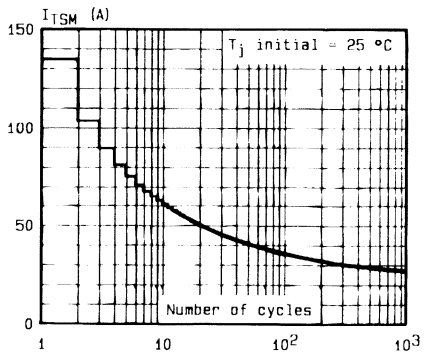

Fig. 6 - Non repetitive surge peak on-state current versus number of cycles.

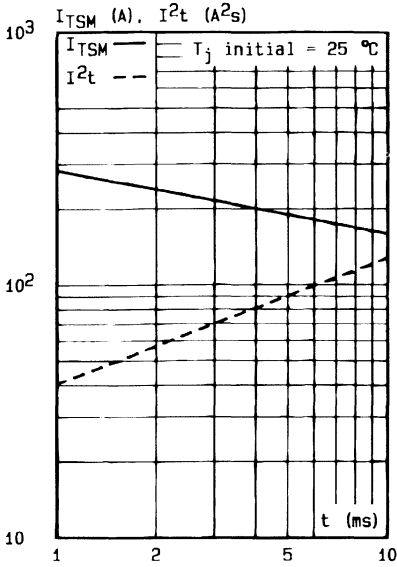

Fig.7 - Non repetitive surge peak on-state current for a sinusoidal pulse with width :  $t \leq 10$  ms, and corresponding value of  $I^2t$ .

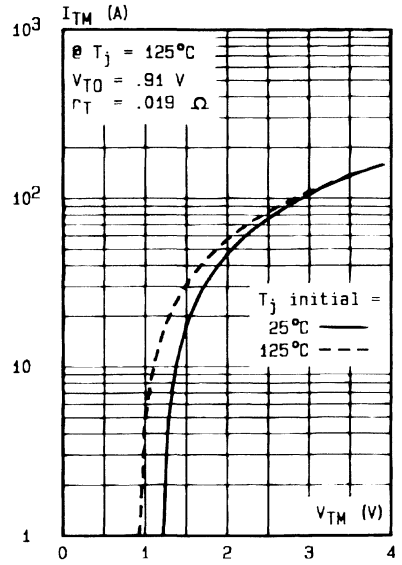
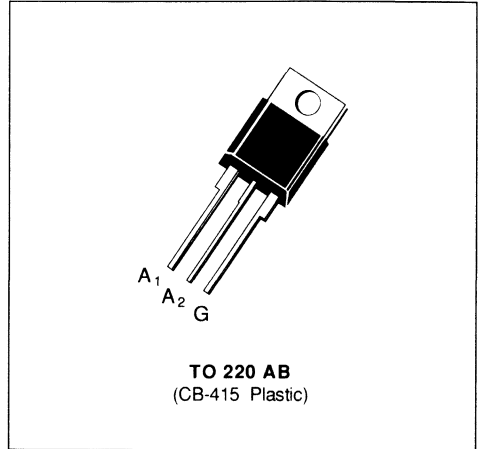

Fig.8 - On-state characteristics (maximum values).



**SNUBBERLESS TRIACS**

- $I_{TRMS} = 16 \text{ A}$  at  $T_c = 80 \text{ }^\circ\text{C}$ .
- $V_{DRM} : 200 \text{ V}$  to  $800 \text{ V}$ .
- $I_{GT} = 50 \text{ mA}$  (QI-II-III).
- GLASS PASSIVATED CHIP.
- HIGH SURGE CURRENT :  $I_{TSM} = 150 \text{ A}$ .
- HIGH COMMUTATION CAPABILITY :  
( $di/dt$ )<sub>c</sub> >  $14 \text{ A / ms}$  without snubber.
- INSULATING VOLTAGE :  $2500 \text{ V}_{RMS}$ .
- UL RECOGNIZED (E81734).

**DESCRIPTION**

New range suited for applications such as phase control and static switching on inductive or resistive load.

**ABSOLUTE RATINGS** (limiting values)

Symbol	Parameter		Value	Unit
$I_{TRMS}$	RMS on-state current (360 ° conduction angle)	$T_c = 80 \text{ }^\circ\text{C}$	16	A
$I_{TSM}$	Non repetitive surge peak on-state current ( $T_j$ initial = $25 \text{ }^\circ\text{C}$ )	$t = 8.3 \text{ ms}$	157	A
		$t = 10 \text{ ms}$	150	
$I^2t$	$I^2t$ value	$t = 10 \text{ ms}$	112	$\text{A}^2\text{s}$
$di/dt$	Critical rate of rise of on-state current (1)	Repetitive $F = 50 \text{ Hz}$	20	$\text{A}/\mu\text{s}$
		Non Repetitive	100	
$T_{stg}$ $T_j$	Storage and operating junction temperature range		- 40, + 150 - 40, + 125	$^\circ\text{C}$ $^\circ\text{C}$

Symbol	Parameter	BTA 16-					Unit
		200 BW	400 BW	600 BW	700 BW	800 BW	
$V_{DRM}$	Repetitive peak off-state voltage (2)	$\pm 200$	$\pm 400$	$\pm 600$	$\pm 700$	$\pm 800$	V

(1) Gate supply :  $I_G = 500 \text{ mA} - di_G / dt = 1 \text{ A} / \mu\text{s}$ .

(2)  $T_j = 125 \text{ }^\circ\text{C}$ .

**THERMAL RESISTANCES**

Symbol	Parameter	Value	Unit
$R_{th(j-a)}$	Junction to ambient	60	°C/W
$R_{th(j-c) DC}$	Junction to case for DC	3.1	°C/W
$R_{th(j-c) AC}$	Junction to case for 360 ° conduction angle (F = 50 Hz)	2.3	°C/W

**GATE CHARACTERISTICS (maximum values)**
 $P_{GM} = 40 \text{ W (} t = 10 \mu\text{s)}$     $P_{G(AV)} = 1 \text{ W}$     $I_{GM} = 4 \text{ A (} t = 10 \mu\text{s)}$     $V_{GM} = 16 \text{ V (} t = 10 \mu\text{s)}$ .

**ELECTRICAL CHARACTERISTICS**

Symbol	Test Conditions			Quadrants	Min.	Typ.	Max.	Unit
$I_{GT}$	$T_J = 25 \text{ °C}$ Pulse duration > 20 $\mu\text{s}$	$V_D = 12 \text{ V}$	$R_L = 33 \text{ }\Omega$	I-II-III	2		50	mA
$V_{GT}$	$T_J = 25 \text{ °C}$ Pulse duration > 20 $\mu\text{s}$	$V_D = 12 \text{ V}$	$R_L = 33 \text{ }\Omega$	I-II-III			1.5	V
$V_{GD}$	$T_J = 125 \text{ °C}$ Pulse duration > 20 $\mu\text{s}$	$V_D = V_{DRM}$	$R_L = 3.3 \text{ k}\Omega$	I-II-III	0.2			V
$I_H^*$	$T_J = 25 \text{ °C}$ Gate open	$I_T = 100 \text{ mA}$ $R_L = 140 \text{ }\Omega$					50	mA
$I_L$	$T_J = 25 \text{ °C}$ Pulse duration > 20 $\mu\text{s}$	$V_D = 12 \text{ V}$	$I_G = 500 \text{ mA}$	I-III		50		mA
				II		100		
$V_{TM}^*$	$T_J = 25 \text{ °C}$	$I_{TM} = 22.5 \text{ A}$	$t_p = 10 \text{ ms}$				1.5	V
$I_{DRM}^*$	$T_J = 25 \text{ °C}$	$V_{DRM}$ rated	Gate open				0.01	mA
	$T_J = 125 \text{ °C}$						2	
$dv/dt^*$	$T_J = 125 \text{ °C}$ Linear slope up to 0.67 $V_{DRM}$	Gate open			500	750		V/ $\mu\text{s}$
$(di/dt)_c^*$	$T_J = 125 \text{ °C}$ Without snubber	$V_{DRM}$ rated			14	28		A/ms
$t_{gt}$	$T_J = 25 \text{ °C}$ $I_T = 22.5 \text{ A}$	$di_G/dt = 3.5 \text{ A}/\mu\text{s}$ $V_D = V_{DRM}$	$I_G = 500 \text{ mA}$	I-II-III		2		$\mu\text{s}$

\* For either polarity of electrode A<sub>2</sub> voltage with reference to electrode A<sub>1</sub>.

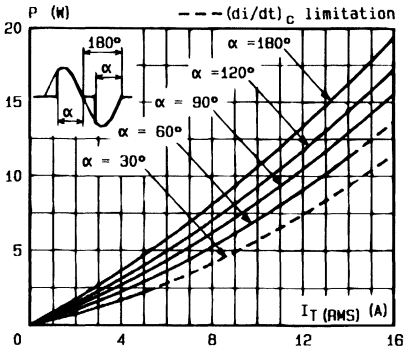

Fig.1 - Maximum mean power dissipation versus RMS on-state current (F = 60 Hz).

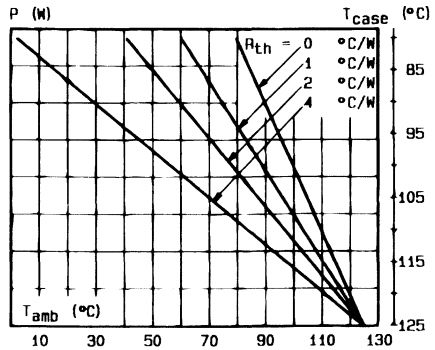

Fig.2 - Correlation between maximum mean power dissipation and maximum allowable temperatures (T<sub>amb</sub> and T<sub>case</sub>) for different thermal resistances heatsink + contact.

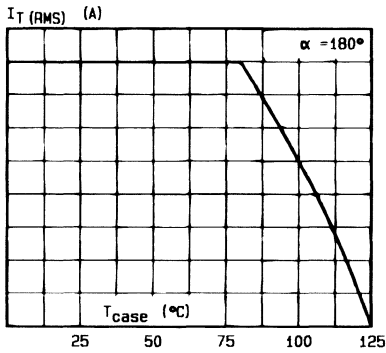

Fig.3 - RMS on-state current versus case temperature.

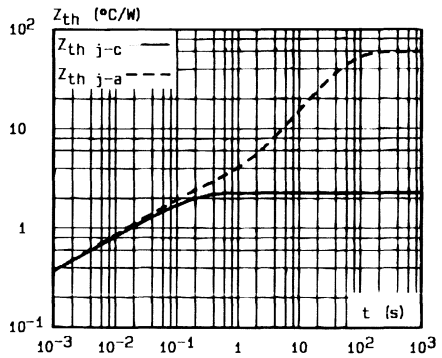

Fig.4 - Thermal transient impedance junction to case and junction to ambient versus pulse duration.

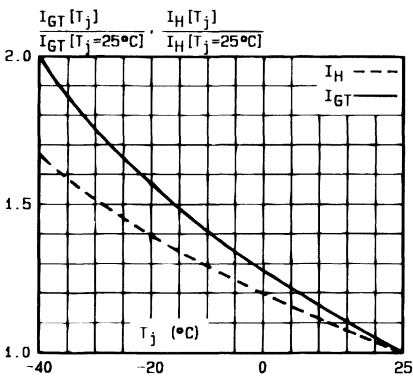

Fig.5 - Relative variation of gate trigger current and holding current versus junction temperature.

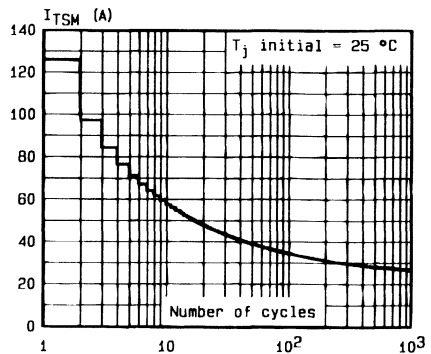

Fig.6 - Non repetitive surge peak on-state current versus number of cycles.

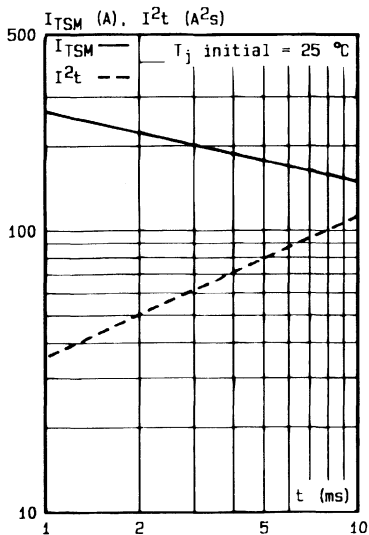

Fig.7 - Non repetitive surge peak on-state current for a sinusoidal pulse with width :  $t \leq 10$  ms, and corresponding value of  $I^2t$ .

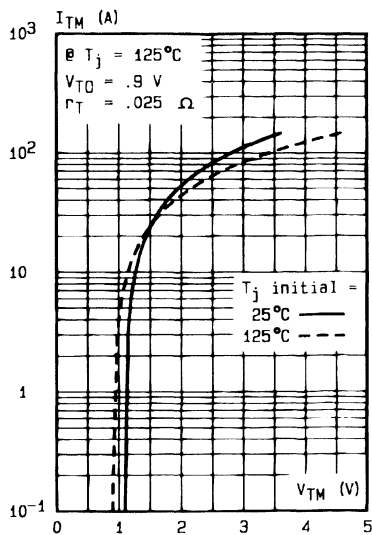
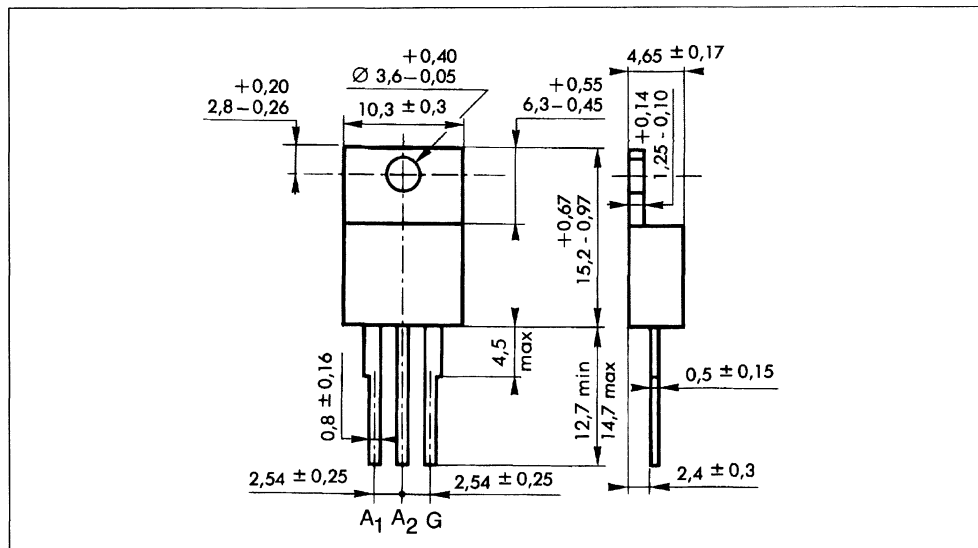

Fig.8 - On-state characteristics (maximum values).

**PACKAGE MECHANICAL DATA**

TO 220 AB (CB-415) Plastic



Cooling method : by conduction (method C)  
 Marking : type number  
 Weight : 2 g

**SNUBBERLESS TRIACS**

- $I_{TRMS} = 16\text{ A}$  at  $T_c = 80\text{ }^\circ\text{C}$ .
- $V_{DRM} : 200\text{ V}$  to  $800\text{ V}$ .
- $I_{GT} = 35\text{ mA}$  (QI-II-III).
- GLASS PASSIVATED CHIP.
- HIGH SURGE CURRENT :  $I_{TSM} = 150\text{ A}$ .
- HIGH COMMUTATION CAPABILITY :  
( $di/dt$ )<sub>c</sub> >  $8.5\text{ A/ms}$  without snubber.
- INSULATING VOLTAGE :  $2500\text{ V}_{RMS}$ .
- UL RECOGNIZED (E81734).

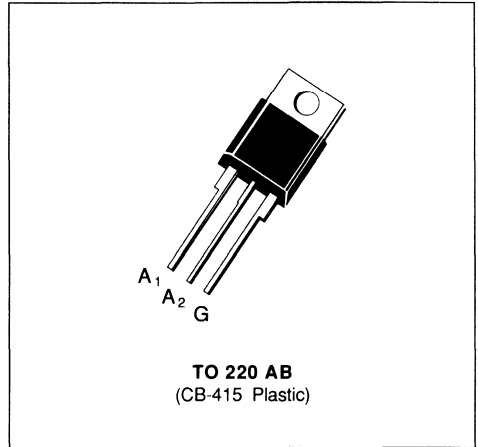
**DESCRIPTION**

New range suited for applications such as phase control and static switching on inductive or resistive load.

**ABSOLUTE RATINGS** (limiting values)

Symbol	Parameter		Value	Unit
$I_{TRMS}$	RMS on-state current (360 ° conduction angle)	$T_c = 80\text{ }^\circ\text{C}$	16	A
$I_{TSM}$	Non repetitive surge peak on-state current ( $T_j$ initial = $25\text{ }^\circ\text{C}$ )	$t = 8.3\text{ ms}$	157	A
		$t = 10\text{ ms}$	150	
$I^2t$	$I^2t$ value	$t = 10\text{ ms}$	112	$\text{A}^2\text{s}$
$di/dt$	Critical rate of rise of on-state current (1)	Repetitive $F = 50\text{ Hz}$	20	A/ $\mu\text{s}$
		Non Repetitive	100	
$T_{stg}$ $T_j$	Storage and operating junction temperature range		- 40, + 150	$^\circ\text{C}$
			- 40, + 125	$^\circ\text{C}$

Symbol	Parameter	BTA 16-					Unit
		200 CW	400 CW	600 CW	700 CW	800 CW	
$V_{DRM}$	Repetitive peak off-state voltage (2)	$\pm 200$	$\pm 400$	$\pm 600$	$\pm 700$	$\pm 800$	V

(1) Gate supply :  $I_G = 350\text{ mA} - di_G / dt = 1\text{ A} / \mu\text{s}$ .

(2)  $T_j = 125\text{ }^\circ\text{C}$ .

**THERMAL RESISTANCES**

Symbol	Parameter	Value	Unit
$R_{th(j-a)}$	Junction to ambient	60	°C/W
$R_{th(j-c)}^{DC}$	Junction to case for DC	3.1	°C/W
$R_{th(j-c)}^{AC}$	Junction to case for 360° conduction angle (F = 50 Hz)	2.3	°C/W

**GATE CHARACTERISTICS (maximum values)**
 $P_{GM} = 40 \text{ W (} t = 10 \mu\text{s)}$     $P_{G(AV)} = 1 \text{ W}$     $I_{GM} = 4 \text{ A (} t = 10 \mu\text{s)}$     $V_{GM} = 16 \text{ V (} t = 10 \mu\text{s)}$ .

**ELECTRICAL CHARACTERISTICS**

Symbol	Test Conditions			Quadrants	Min.	Typ.	Max.	Unit
$I_{GT}$	$T_j = 25 \text{ °C}$ Pulse duration > 20 $\mu\text{s}$	$V_D = 12 \text{ V}$	$R_L = 33 \text{ }\Omega$	I-II-III	1		35	mA
$V_{GT}$	$T_j = 25 \text{ °C}$ Pulse duration > 20 $\mu\text{s}$	$V_D = 12 \text{ V}$	$R_L = 33 \text{ }\Omega$	I-II-III			1.5	V
$V_{GD}$	$T_j = 125 \text{ °C}$ Pulse duration > 20 $\mu\text{s}$	$V_D = V_{DRM}$	$R_L = 3.3 \text{ k}\Omega$	I-II-III	0.2			V
$I_H^*$	$T_j = 25 \text{ °C}$ Gate open	$I_T = 100 \text{ mA}$ $R_L = 140 \text{ }\Omega$					35	mA
$I_L$	$T_j = 25 \text{ °C}$ Pulse duration > 20 $\mu\text{s}$	$V_D = 12 \text{ V}$	$I_G = 350 \text{ mA}$	I-III			50	mA
				II			80	
$V_{TM}^*$	$T_j = 25 \text{ °C}$	$I_{TM} = 22.5 \text{ A}$	$t_p = 10 \text{ ms}$				1.5	V
$I_{DRM}^*$	$T_j = 25 \text{ °C}$	$V_{DRM}$ rated	Gate open				0.01	mA
	$T_j = 125 \text{ °C}$						2	
$dv/dt^*$	$T_j = 125 \text{ °C}$	Gate open Linear slope up to 0.67 $V_{DRM}$			250	500		V/ $\mu\text{s}$
$(di/dt)_c^*$	$T_j = 125 \text{ °C}$	$V_{DRM}$ rated Without snubber			8.5	17		A/ms
$t_{gt}$	$T_j = 25 \text{ °C}$ $I_T = 22.5 \text{ A}$	$di_G/dt = 1 \text{ A}/\mu\text{s}$	$I_G = 350 \text{ mA}$ $V_D = V_{DRM}$	I-II-III		2		$\mu\text{s}$

\* For either polarity of electrode A<sub>2</sub> voltage with reference to electrode A<sub>1</sub>.

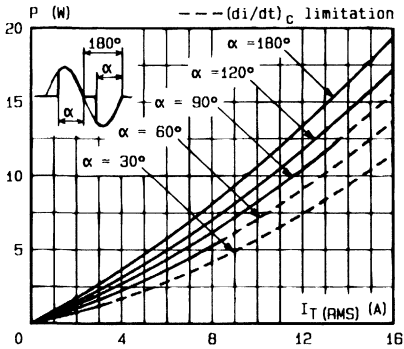

Fig. 1 - Maximum mean power dissipation versus RMS on-state current ( $F = 60 \text{ Hz}$ ).

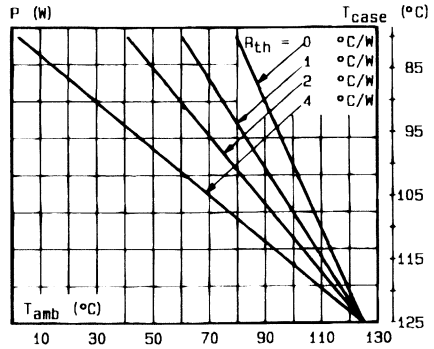

Fig. 2 - Correlation between maximum mean power dissipation and maximum allowable temperatures ( $T_{amb}$  and  $T_{case}$ ) for different thermal resistances heatsink + contact.

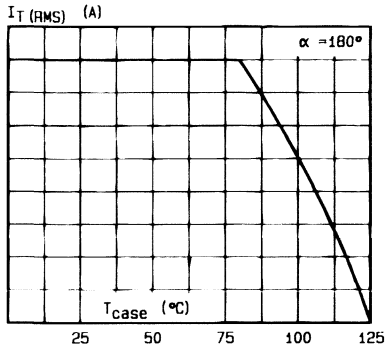

Fig. 3 - RMS on-state current versus case temperature.

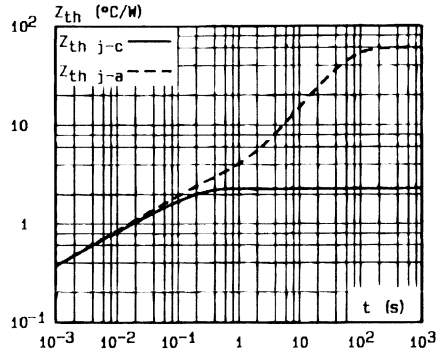

Fig. 4 - Thermal transient impedance junction to case and junction to ambient versus pulse duration.

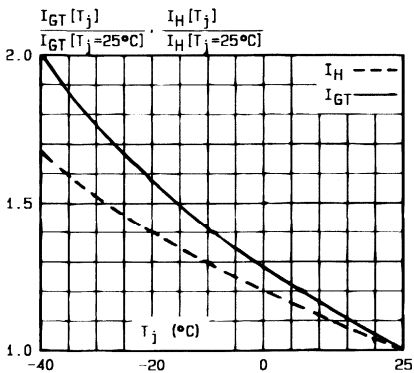

Fig. 5 - Relative variation of gate trigger current and holding current versus junction temperature.

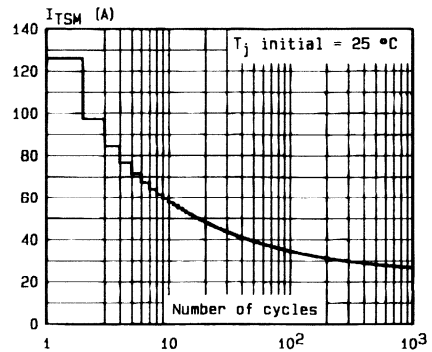

Fig. 6 - Non repetitive surge peak on-state current versus number of cycles.

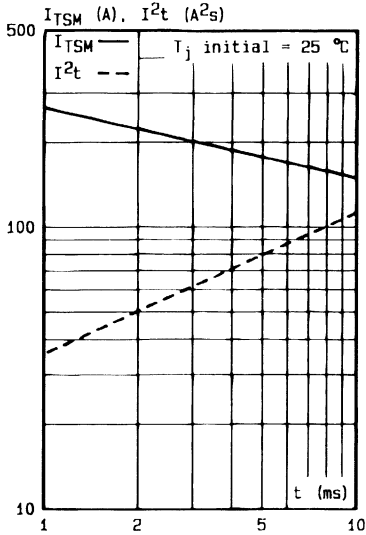

Fig.7 - Non repetitive surge peak on-state current for a sinusoidal pulse with width :  $t \leq 10$  ms, and corresponding value of  $I^2t$ .

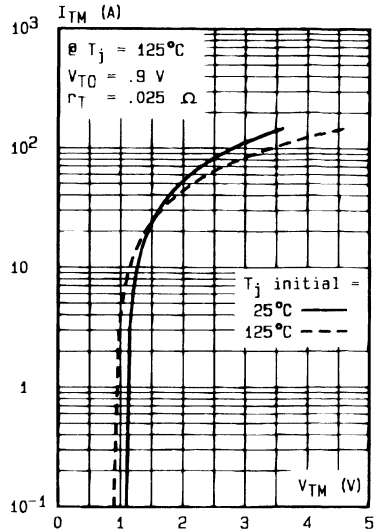
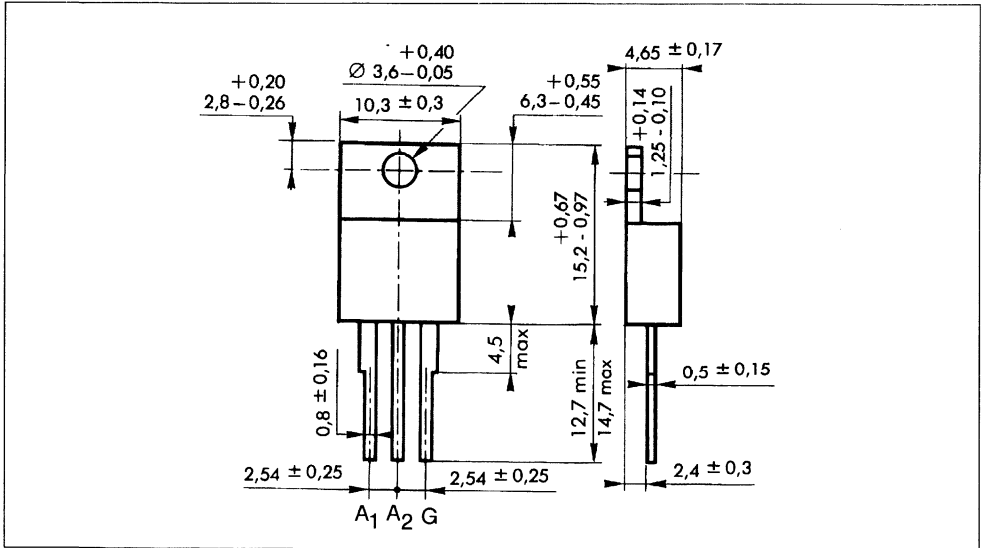

Fig.8 - On-state characteristics (maximum values).

PACKAGE MECHANICAL DATA

TO 220 AB (CB-415) Plastic



Cooling method : by conduction (method C)

Marking : type number

Weight : 2 g



## TRIACS

- GLASS PASSIVATED CHIP
- FAST-ON CONNEXIONS
- $I_{GT}$  SPECIFIED IN FOUR QUADRANTS
- INSULATING VOLTAGE 2500  $V_{RMS}$
- UL RECOGNIZED (E81734)

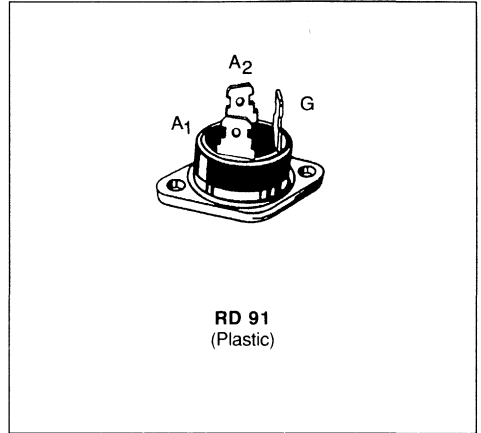

### DESCRIPTION

This new design of plastic insulated power triacs offers maximum efficiency with maximum ease of mounting.

### ADVANTAGES

- NO TAPPING REQUIRED FOR FIXING
- EXCELLENT THERMAL IMPEDANCE AND HIGH RELIABILITY CONSTRUCTION

### ABSOLUTE RATINGS (limiting values)

Symbol	Parameter		Value	Unit
$I_{T(RMS)}$	RMS on-state Current (360° conduction angle)	$T_C = 80\text{ °C}$	30	A
$I_{TSM}$	Non Repetitive Surge Peak on-state Current ( $T_J$ initial = 25 °C - Half sine wave)	$t = 8.3\text{ ms}$	260	A
		$t = 10\text{ ms}$	250	
$I^2t$	$I^2t$ Value for Fusing	$t = 10\text{ ms}$	312.5	A <sup>2</sup> s
di/dt	Critical Rate of Rise of on-state Current (1)	Repetitive F = 50 Hz	10	A/μs
		Non Repetitive	50	
$T_{stg}$ $T_J$	Storage and Operating Junction Temperature Range		- 40 to 125	°C
			- 40 to 125	°C

Symbol	Parameter	BTA 25-					Unit
		200A	400A	600A	700A	800A	
$V_{DRM}$	Repetitive Peak off-state Voltage (2)	200	400	600	700	800	V

(1)  $I_G = 1.5\text{ A}$  di/dt = 1 A/μs  
 (2)  $T_J = 125\text{ °C}$ .

### THERMAL RESISTANCES

Symbol	Parameter	Value	Unit
$R_{th(c-h)}$	Contact (case- heatsink) with Grease	0.15	°C/W
$R_{th(j-c)}\text{ DC}$	Junction to Case for DC	1.47	°C/W
$R_{th(j-c)}\text{ AC}$	Junction to Case for 360 ° Conduction Angle (F = 50 Hz)	1.1	°C/W

**GATE CHARACTERISTICS (maximum values)**

$P_{GM} = 40 \text{ W}$  ( $t_p = 10 \mu\text{s}$ )

$P_{G(AV)} = 1 \text{ W}$

$I_{GM} = 6 \text{ A}$  ( $t_p = 10 \mu\text{s}$ )

$V_{GM} = 16 \text{ V}$  ( $t_p = 10 \mu\text{s}$ )

**ELECTRICAL CHARACTERISTICS**

Symbol	Test Conditions			Quadrants	Min.	Typ.	Max.	Unit
$I_{GT}$	$T_j = 25 \text{ }^\circ\text{C}$ Pulse Duration > 20 $\mu\text{s}$	$V_D = 12 \text{ V}$	$R_L = 33 \text{ } \Omega$	I-II-III	1		100	mA
				IV	1		150	
$V_{GT}$	$T_j = 25 \text{ }^\circ\text{C}$ Pulse Duration > 20 $\mu\text{s}$	$V_D = 12 \text{ V}$	$R_L = 33 \text{ } \Omega$	I-II-III-IV			1.5	V
$V_{GD}$	$T_j = 125 \text{ }^\circ\text{C}$	$V_D = V_{DRM}$	$R_L = 3.3 \text{ k}\Omega$	I-II-III-IV	0.2			V
$I_H^*$	$T_j = 25 \text{ }^\circ\text{C}$	$I_T = 500 \text{ mA}$	Gate Open			30	100	mA
$I_L$	$T_j = 25 \text{ }^\circ\text{C}$ Pulse Duration > 20 $\mu\text{s}$	$V_D = 12 \text{ V}$	$I_G = 300 \text{ mA}$	I-II-III-IV			150	mA
$V_{TM}^*$	$T_j = 25 \text{ }^\circ\text{C}$	$I_{TM} = 42 \text{ A}$	$t_p = 10 \text{ ms}$				1.8	V
$I_{DRM}^*$	$T_j = 125 \text{ }^\circ\text{C}$	$V_{DRM}$ Specified				1.5	6	mA
$dv/dt^*$	$T_j = 125 \text{ }^\circ\text{C}$	Gate Open Linear Slope up to $V_D = 67\% V_{DRM}$			250			V/ $\mu\text{s}$
$(dv/dt)_c^*$	$T_C = 80 \text{ }^\circ\text{C}$	$V_D = V_{DRM}$	$I_T = 42 \text{ A}$ $(di/dt)_c = 13.3 \text{ A/ms}$		10			V/ $\mu\text{s}$
$t_{gt}$	$T_j = 25 \text{ }^\circ\text{C}$	$V_D = V_{DRM}$	$I_T = 42 \text{ A}$ $I_G = 1 \text{ A}$ $di_G/dt = 10 \text{ A}/\mu\text{s}$	I-II-III-IV		2.5		$\mu\text{s}$

\* For either polarity of electrode  $A_2$  voltage with reference to electrode  $A_1$ .

**PACKAGE MECHANICAL DATA : RD 91 Plastic**

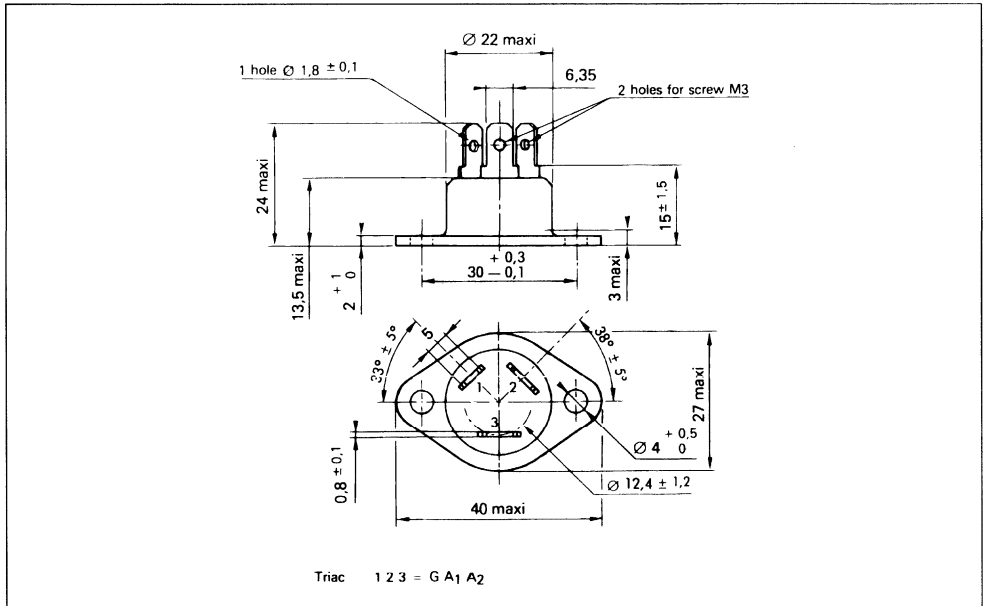

Cooling method : by conduction (method C)

Marking : type number

Weight : 15 g

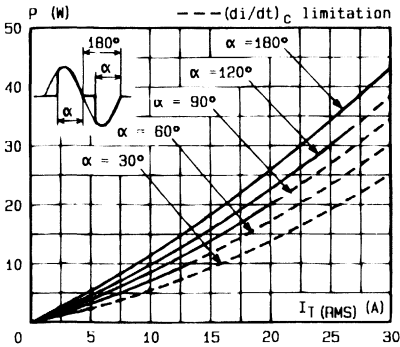

Fig.1 - Maximum mean power dissipation versus RMS on-state current ( $f = 60$  Hz).

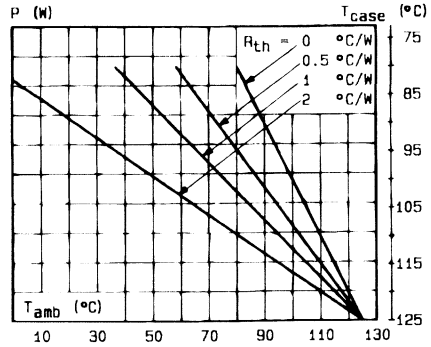

Fig.2 - Correlation between maximum mean power dissipation and maximum allowable temperatures ( $T_{amb}$  and  $T_{case}$ ) for different thermal resistances heatsink + contact.

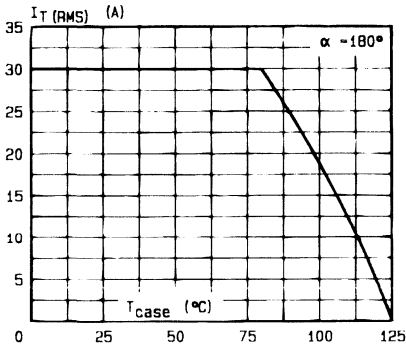

Fig.3 - RMS on-state current versus case temperature.

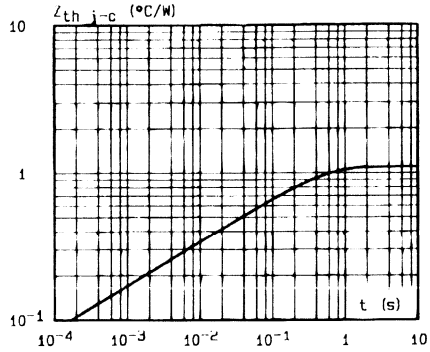

Fig.4 - Thermal transient impedance junction to case versus pulse duration.

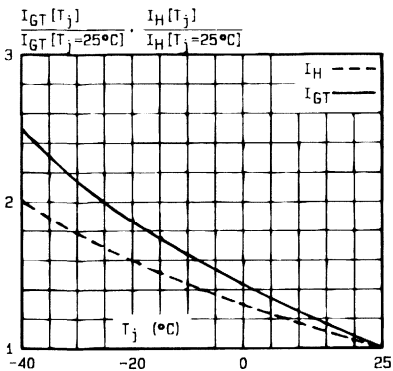

Fig.5 - Relative variation of gate trigger current and holding current versus junction temperature.

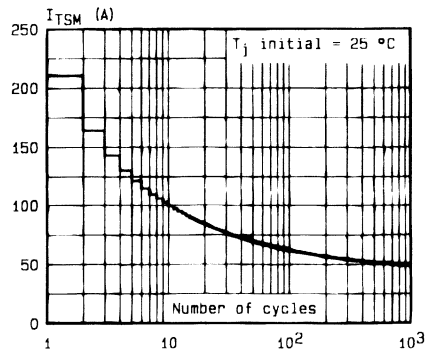

Fig.6 - Non repetitive surge peak on-state current versus number of cycles.

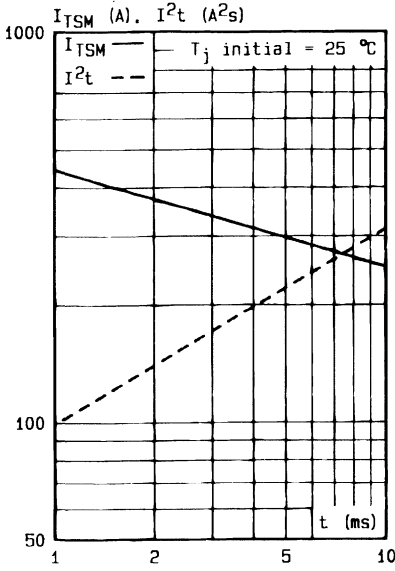

Fig. 7 - Non repetitive surge peak on-state current for a sinusoidal pulse with width :  $t \leq 10$  ms, and corresponding value of  $I^2t$ .

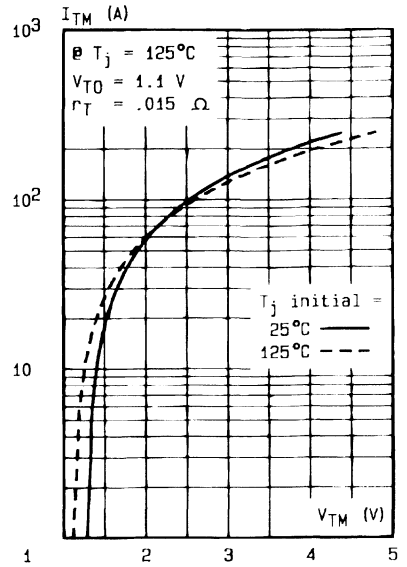

Fig. 8 - On-state characteristics (maximum values).

**TRIACS**

- GLASS PASSIVATED CHIP
- FAST-ON CONNEXIONS
- $I_{GT}$  SPECIFIED IN FOUR QUADRANTS
- INSULATING VOLTAGE 2500  $V_{RMS}$
- UL RECOGNIZED (E81734)

**DESCRIPTION**

This new design of plastic insulated power triacs offers maximum efficiency with maximum ease of mounting.

**ADVANTAGES**

- NO TAPPING REQUIRED FOR FIXING
- EXCELLENT THERMAL IMPEDANCE AND HIGH RELIABILITY CONSTRUCTION

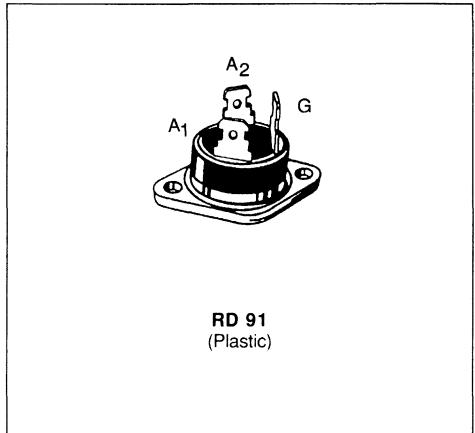
**ABSOLUTE RATINGS** (limiting values)

Symbol	Parameter	Value	Unit
$I_{T(RMS)}$	RMS on-state Current (360° conduction angle)	$T_C = 80^\circ C$ 30	A
$I_{TSM}$	Non Repetitive Surge Peak on-state Current ( $T_j$ initial = 25 °C - Half sine wave)	$t = 8.3$ ms	260
		$t = 10$ ms	250
$I^2t$	$I^2t$ Value for Fusing	$t = 10$ ms	312.5
$di/dt$	Critical Rate of Rise of on-state Current (1)	Repetitive $F = 50$ Hz	10
		Non Repetitive	50
$T_{stg}$ $T_j$	Storage and Operating Junction Temperature Range	- 40 to 125	°C
		- 40 to 125	°C

Symbol	Parameter	BTA 25-					Unit
		200B	400B	600B	700B	800B	
$V_{DRM}$	Repetitive Peak off-state Voltage (2)	200	400	600	700	800	V

(1)  $I_G = 1$  A  $di/dt = 1$  A/ $\mu$ s

(2)  $T_j = 125^\circ C$ .

**THERMAL RESISTANCES**

Symbol	Parameter	Value	Unit
$R_{th(c-h)}$	Contact (case-heatsink) with Grease	0.15	°C/W
$R_{th(j-c)}$ DC	Junction to Case for DC	1.47	°C/W
$R_{th(j-c)}$ AC	Junction to Case for 360° Conduction Angle ( $F = 50$ Hz)	1.1	°C/W



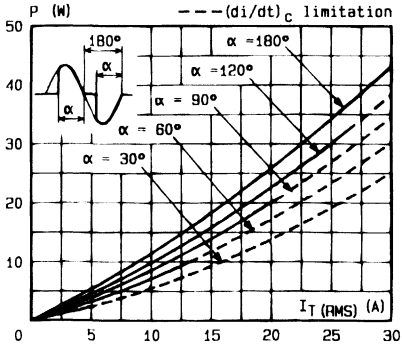

Fig. 1 - Maximum mean power dissipation versus RMS on-state current (f = 60 Hz).

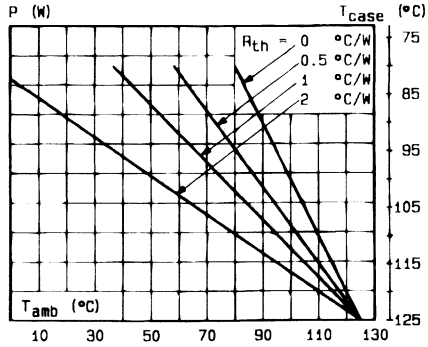

Fig. 2 - Correlation between maximum mean power dissipation and maximum allowable temperatures (T<sub>amb</sub> and T<sub>case</sub>) for different thermal resistances heatsink + contact.

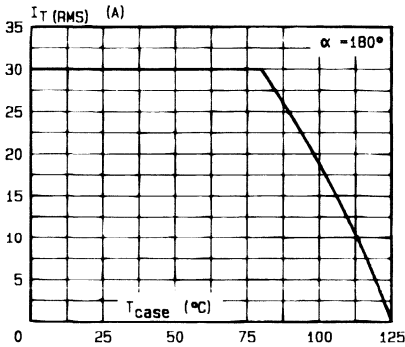

Fig. 3 - RMS on-state current versus case temperature.

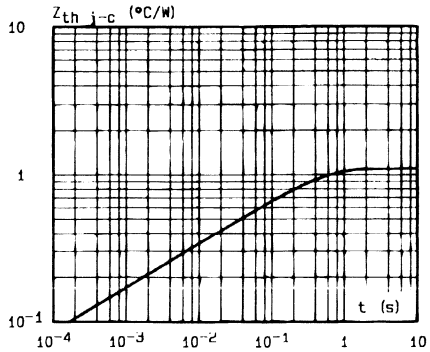

Fig. 4 - Thermal transient impedance junction to case versus pulse duration.

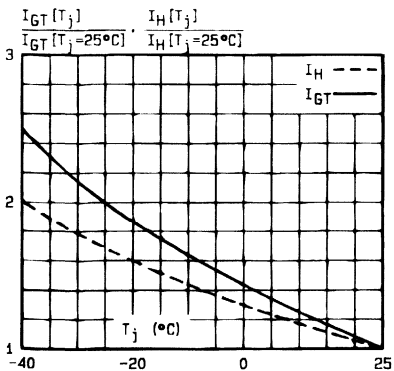

Fig. 5 - Relative variation of gate trigger current and holding current versus junction temperature.

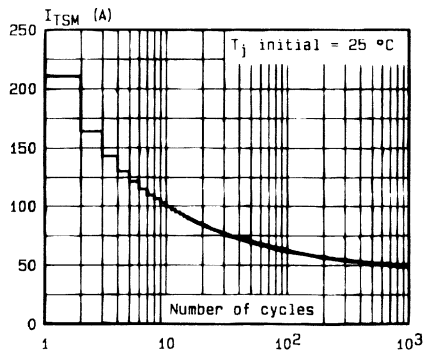

Fig. 6 - Non repetitive surge peak on-state current versus number of cycles.

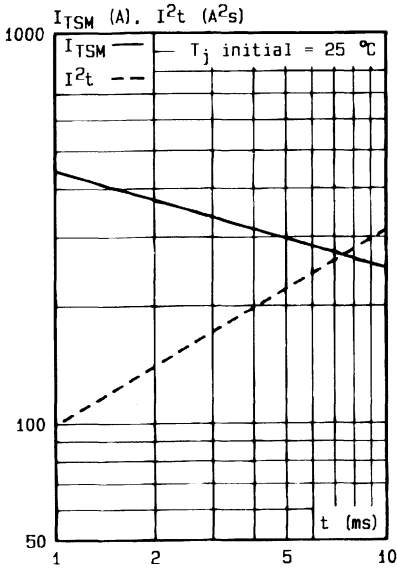

Fig.7 - Non repetitive surge peak on-state current for a sinusoidal pulse with width :  $t \leq 10$  ms, and corresponding value of  $I^2t$ .

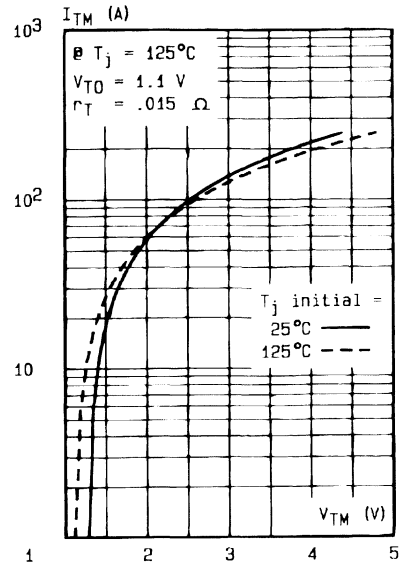

Fig.8 - On-state characteristics (maximum values).



**TRIACS**

- GLASS PASSIVATED CHIP
- $I_{GT}$  SPECIFIED IN FOUR QUADRANTS
- INSULATING VOLTAGE 2500  $V_{RMS}$
- UL RECOGNIZED (E81734)

**DESCRIPTION**

This new design of plastic insulated power triacs offers maximum efficiency with maximum ease of mounting.

**ADVANTAGES**

- NO TAPPING REQUIRED FOR FIXING
- EXCELLENT THERMAL IMPEDANCE AND HIGH RELIABILITY CONSTRUCTION

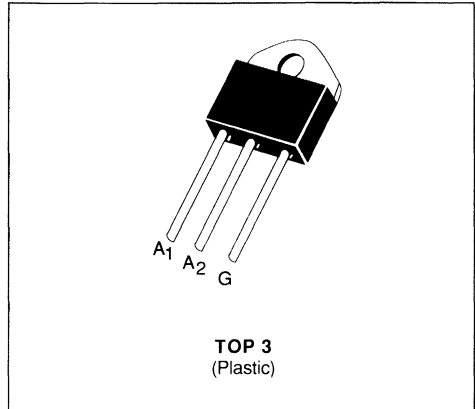
**ABSOLUTE RATINGS** (limiting values)

Symbol	Parameter	Value	Unit
$I_{T(RMS)}$	RMS on-state Current (360° conduction angle)	$T_C = 90\text{ °C}$ 25	A
$I_{TSM}$	Non Repetitive Surge Peak on-state Current ( $T_J$ initial = 25 °C - Half sine wave)	$t = 8.3\text{ ms}$	260
		$t = 10\text{ ms}$	250
$I^2t$	$I^2t$ Value for Fusing	$t = 10\text{ ms}$ 312.5	A <sup>2</sup> s
di/dt	Critical Rate of Rise of on-state Current (1)	Repetitive $F = 50\text{ Hz}$	10
		Non Repetitive	50
$T_{stg}$ $T_J$	Storage and Operating Junction Temperature Range	- 40 to 125 - 40 to 125	°C °C

Symbol	Parameter	BTA 26-					Unit
		200A	400A	600A	700A	800A	
$V_{DRM}$	Repetitive Peak off-state Voltage (2)	200	400	600	700	800	V

- (1)  $I_G = 1.5\text{ A}$      $di_c/dt = 1\text{ A}/\mu\text{s}$   
 (2)  $T_J = 125\text{ °C}$ .

**THERMAL RESISTANCES**

Symbol	Parameter	Value	Unit
$R_{th(j-a)}$	Junction to Ambient	50	°C/W
$R_{th(c-h)}$	Contact (case-heatsink) with Grease	0.2	°C/W
$R_{th(j-c)}\text{ DC}$	Junction to Case for DC	1.45	°C/W
$R_{th(j-c)}\text{ AC}$	Junction to Case for 360 ° Conduction Angle ( $F = 50\text{ Hz}$ )	1.1	°C/W

**GATE CHARACTERISTICS** (maximum values)

$P_{GM} = 40 \text{ W}$  ( $t_p = 10 \mu\text{s}$ )

$I_{GM} = 6 \text{ A}$  ( $t_p = 10 \mu\text{s}$ )

$P_{G(AV)} = 1 \text{ W}$

$V_{GM} = 16 \text{ V}$  ( $t_p = 10 \mu\text{s}$ )

**ELECTRICAL CHARACTERISTICS**

Symbol	Test Conditions			Quadrants	Min.	Typ.	Max.	Unit
$I_{GT}$	$T_j = 25 \text{ }^\circ\text{C}$ Pulse Duration $> 20 \mu\text{s}$	$V_D = 12 \text{ V}$	$R_L = 33 \Omega$	I-II-III	1		100	mA
				IV	1		150	
$V_{GT}$	$T_j = 25 \text{ }^\circ\text{C}$ Pulse Duration $> 20 \mu\text{s}$	$V_D = 12 \text{ V}$	$R_L = 33 \Omega$	I-II-III-IV			1.5	V
$V_{GD}$	$T_j = 125 \text{ }^\circ\text{C}$	$V_D = V_{DRM}$	$R_L = 3.3 \text{ k}\Omega$	I-II-III-IV	0.2			V
$I_H^*$	$T_j = 25 \text{ }^\circ\text{C}$	$I_T = 500 \text{ mA}$	Gate Open			30	100	mA
$I_L$	$T_j = 25 \text{ }^\circ\text{C}$ Pulse Duration $> 20 \mu\text{s}$	$V_D = 12 \text{ V}$	$I_G = 300 \text{ mA}$	I-II-III-IV			150	mA
$V_{TM}^*$	$T_j = 25 \text{ }^\circ\text{C}$	$I_{TM} = 35 \text{ A}$	$t_p = 10 \text{ ms}$				1.7	V
$I_{DRM}^*$	$T_j = 125 \text{ }^\circ\text{C}$	$V_{DRM}$ Specified				1.5	6	mA
$dv/dt^*$	$T_j = 125 \text{ }^\circ\text{C}$	Gate Open	Linear Slope up to $V_D = 67\% V_{DRM}$		250			V/ $\mu\text{s}$
$(dv/dt)_c^*$	$T_C = 90 \text{ }^\circ\text{C}$ $(di/dt)_c = 11.1 \text{ A/ms}$	$V_D = V_{DRM}$	$I_T = 35 \text{ A}$		10			V/ $\mu\text{s}$
$t_{gt}$	$T_j = 25 \text{ }^\circ\text{C}$	$V_D = V_{DRM}$ $I_G = 1 \text{ A}$	$I_T = 35 \text{ A}$ $di_G/dt = 10 \text{ A}/\mu\text{s}$	I-II-III-IV		2.5		$\mu\text{s}$

\* For either polarity of electrode  $A_2$  voltage with reference to electrode  $A_1$ .

**PACKAGE MECHANICAL DATA**

TOP 3 Plastic

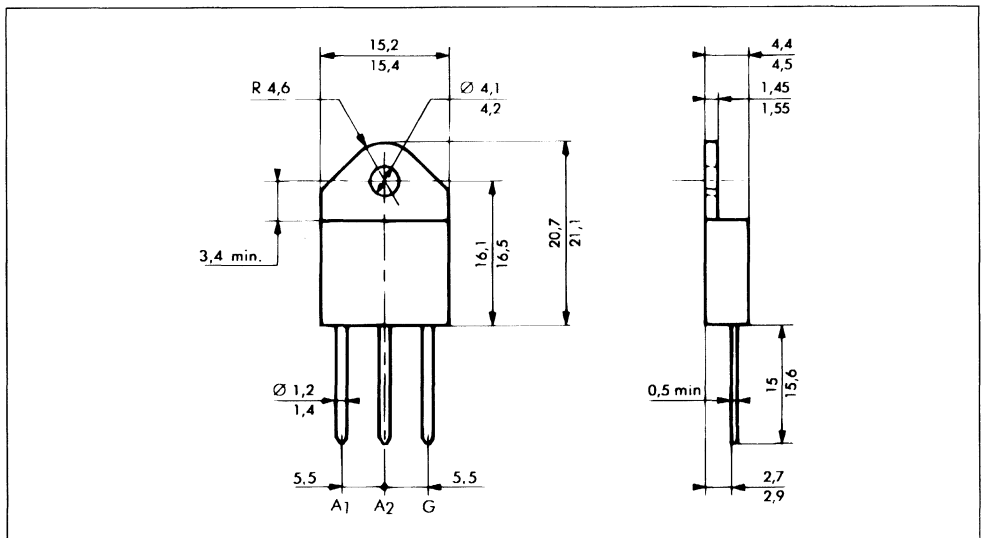

Cooling method : by conduction (method C)

Marking : type number

Weight : 5 g

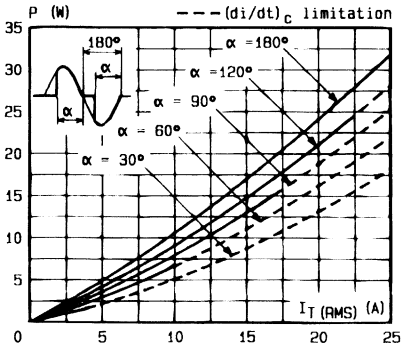

Fig. 1 - Maximum mean power dissipation versus RMS on-state current ( $F = 60$  Hz).

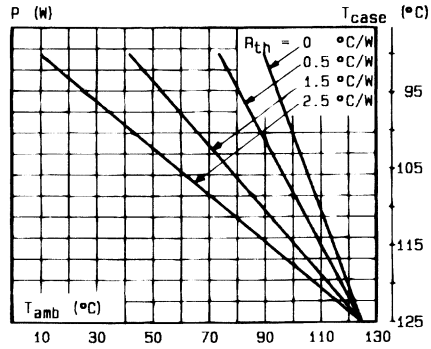

Fig. 2 - Correlation between maximum mean power dissipation and maximum allowable temperatures ( $T_{amb}$  and  $T_{case}$ ) for different thermal resistances heatsink + contact.

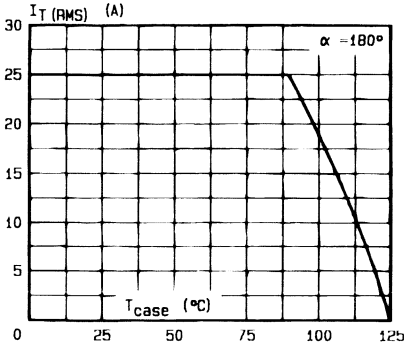

Fig. 3 - RMS on-state current versus case temperature.

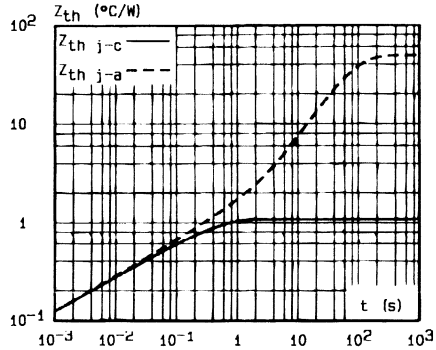

Fig. 4 - Thermal transient impedance junction to case and junction to ambient versus pulse duration.

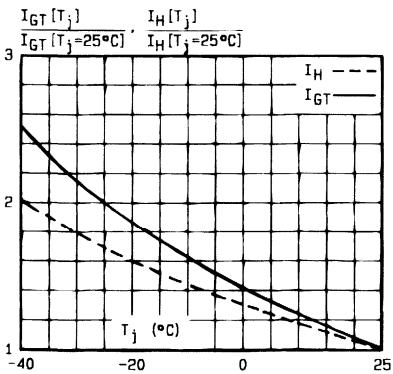

Fig. 5 - Relative variation of gate trigger current and holding current versus junction temperature.

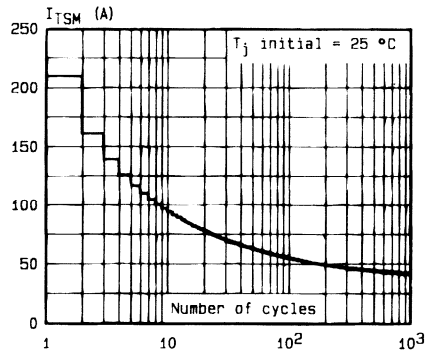

Fig. 6 - Non repetitive surge peak on-state current versus number of cycles.

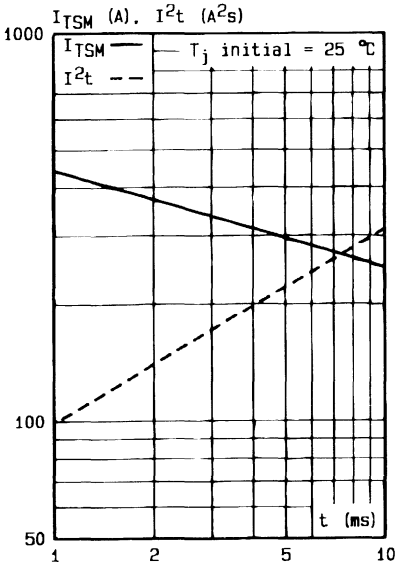

Fig.7 - Non repetitive surge peak on-state current for a sinusoidal pulse with width :  $t \leq 10$  ms, and corresponding value of  $I^2t$ .

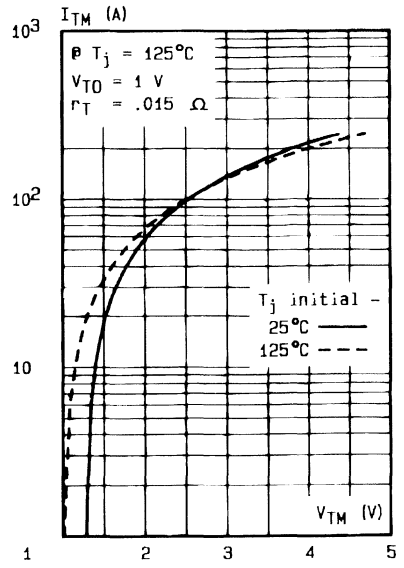
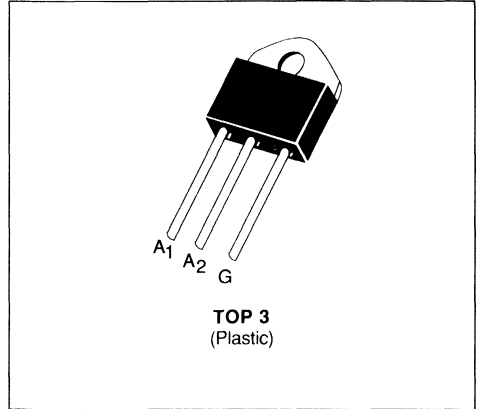

Fig.8 - On-state characteristics (maximum values).

**TRIACS**

- GLASS PASSIVATED CHIP
- $I_{GT}$  SPECIFIED IN FOUR QUADRANTS
- INSULATING VOLTAGE 2500  $V_{RMS}$
- UL RECOGNIZED (E81734)

**DESCRIPTION**

This new design of plastic insulated power triacs offers maximum efficiency with maximum ease of mounting.

**ADVANTAGES**

- NO TAPPING REQUIRED FOR FIXING
- EXCELLENT THERMAL IMPEDANCE AND HIGH RELIABILITY CONSTRUCTION

**ABSOLUTE RATINGS** (limiting values)

Symbol	Parameter	Value	Unit
$I_{T(RMS)}$	RMS on-state Current (360° conduction angle)	$T_C = 90\text{ }^\circ\text{C}$ 25	A
$I_{TSM}$	Non Repetitive Surge Peak on-state Current ( $T_j$ initial = 25 °C - Half sine wave)	$t = 8.3\text{ ms}$	260
		$t = 10\text{ ms}$	250
$I^2t$	$I^2t$ Value for Fusing	$t = 10\text{ ms}$	312.5
di/dt	Critical Rate of Rise of on-state Current (1)	Repetitive $F = 50\text{ Hz}$	10
		Non Repetitive	50
$T_{stg}$	Storage and Operating Junction Temperature Range	- 40 to 125	°C
$T_j$		- 40 to 125	°C

Symbol	Parameter	BTA 26-					Unit
		200B	400B	600B	700B	800B	
$V_{DRM}$	Repetitive Peak off-state Voltage (2)	200	400	600	700	800	V

(1)  $I_G = 1\text{ A}$   $di_G/dt = 1\text{ A}/\mu\text{s}$

(2)  $T_j = 125\text{ }^\circ\text{C}$ .

**THERMAL RESISTANCES**

Symbol	Parameter	Value	Unit
$R_{th(j-a)}$	Junction to Ambient	50	°C/W
$R_{th(c-h)}$	Contact (case-heat-sink) with Grease	0.2	°C/W
$R_{th(j-c)}\text{ DC}$	Junction to Case for DC	1.45	°C/W
$R_{th(j-c)}\text{ AC}$	Junction to Case for 360 ° Conduction Angle ( $F = 50\text{ Hz}$ )	1.1	°C/W

**GATE CHARACTERISTICS** (maximum values)

$P_{GM} = 40 \text{ W}$  ( $t_p = 10 \mu\text{s}$ )       $I_{GM} = 6 \text{ A}$  ( $t_p = 10 \mu\text{s}$ )  
 $P_{G(AV)} = 1 \text{ W}$        $V_{GM} = 16 \text{ V}$  ( $t_p = 10 \mu\text{s}$ )

**ELECTRICAL CHARACTERISTICS**

Symbol	Test Conditions			Quadrants	Min.	Typ.	Max.	Unit
$I_{GT}$	$T_j = 25 \text{ }^\circ\text{C}$ Pulse Duration > 20 $\mu\text{s}$	$V_D = 12 \text{ V}$	$R_L = 33 \text{ } \Omega$	I-II-III	1		50	mA
				IV	1		100	
$V_{GT}$	$T_j = 25 \text{ }^\circ\text{C}$ Pulse Duration > 20 $\mu\text{s}$	$V_D = 12 \text{ V}$	$R_L = 33 \text{ } \Omega$	I-II-III-IV			1.5	V
$V_{GD}$	$T_j = 125 \text{ }^\circ\text{C}$	$V_D = V_{DRM}$	$R_L = 3.3 \text{ k}\Omega$	I-II-III-IV	0.2			V
$I_{H^*}$	$T_j = 25 \text{ }^\circ\text{C}$	$I_T = 500 \text{ mA}$	Gate Open			30	80	mA
$I_L$	$T_j = 25 \text{ }^\circ\text{C}$ Pulse Duration > 20 $\mu\text{s}$	$V_D = 12 \text{ V}$	$I_G = 200 \text{ mA}$	I-II-III-IV			100	mA
$V_{TM}^*$	$T_j = 25 \text{ }^\circ\text{C}$	$I_{TM} = 35 \text{ A}$	$t_p = 10 \text{ ms}$				1.7	V
$I_{DRM}^*$	$T_j = 125 \text{ }^\circ\text{C}$	$V_{DRM}$ Specified				1.5	6	mA
$dv/dt^*$	$T_j = 125 \text{ }^\circ\text{C}$ Linear Slope up to $V_D = 67\% V_{DRM}$	Gate Open			250			V/ $\mu\text{s}$
$(dv/dt)_c^*$	$T_C = 90 \text{ }^\circ\text{C}$ $(di/dt)_c = 11.1 \text{ A/ms}$	$V_D = V_{DRM}$	$I_T = 35 \text{ A}$		5			V/ $\mu\text{s}$
$t_{gt}$	$T_j = 25 \text{ }^\circ\text{C}$ $I_G = 1 \text{ A}$	$V_D = V_{DRM}$ $di_G/dt = 10 \text{ A}/\mu\text{s}$	$I_T = 35 \text{ A}$	I-II-III-IV		2.5		$\mu\text{s}$

\* For either polarity of electrode  $A_2$  voltage with reference to electrode  $A_1$ .

**PACKAGE MECHANICAL DATA**

TOP 3 Plastic

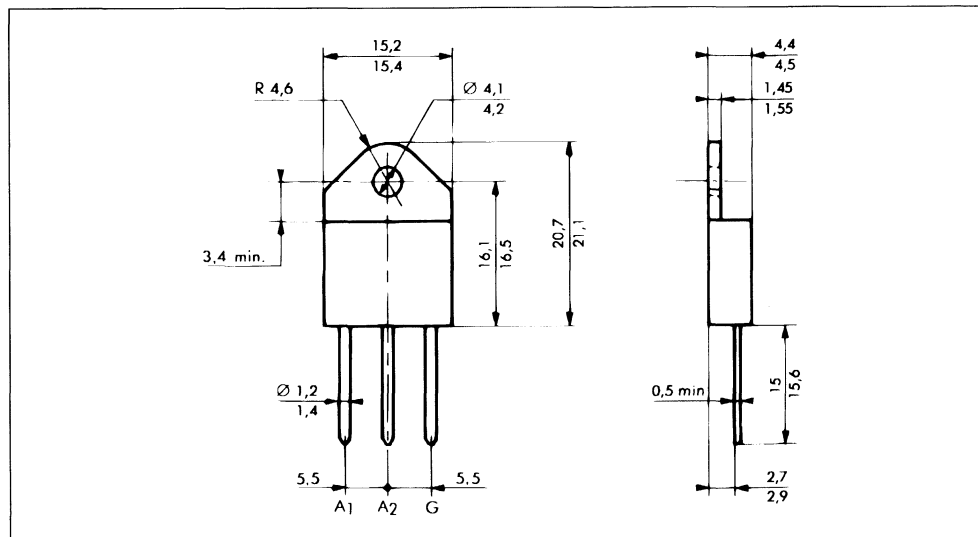

Cooling method : by conduction (method C)  
 Marking : type number  
 Weight : 5 g

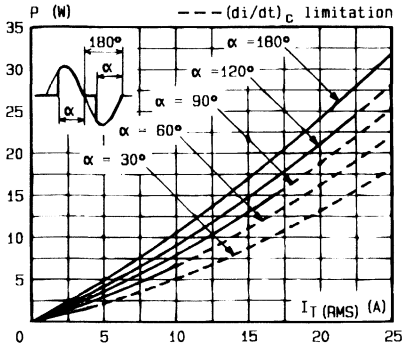

Fig. 1 - Maximum mean power dissipation versus RMS on-state current ( $F = 60$  Hz).

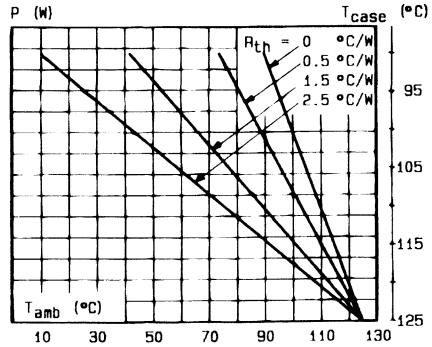

Fig. 2 - Correlation between maximum mean power dissipation and maximum allowable temperatures ( $T_{amb}$  and  $T_{case}$ ) for different thermal resistances heatsink + contact.

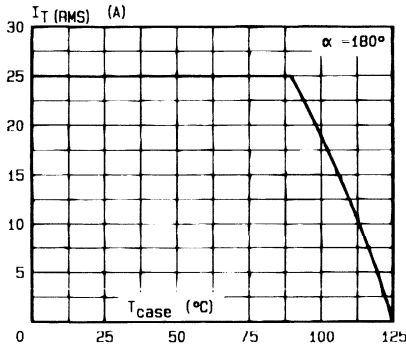

Fig. 3 - RMS on-state current versus case temperature.

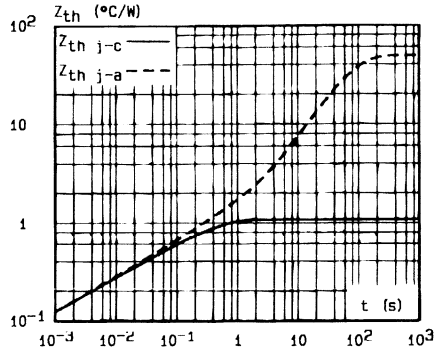

Fig. 4 - Thermal transient impedance junction to case and junction to ambient versus pulse duration.

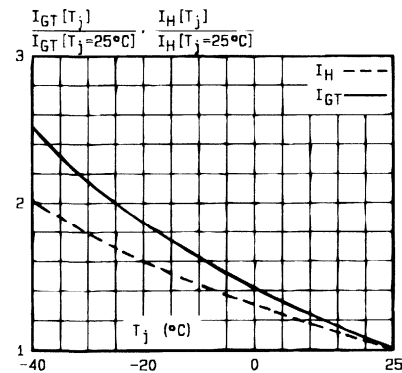

Fig. 5 - Relative variation of gate trigger current and holding current versus junction temperature.

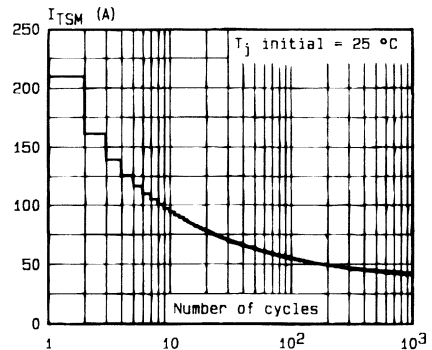

Fig. 6 - Non repetitive surge peak on-state current versus number of cycles.

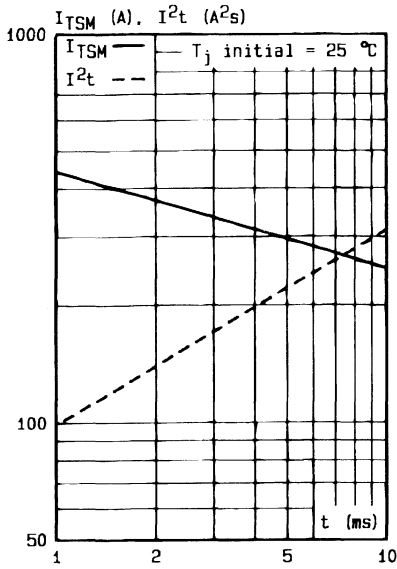

Fig.7 - Non repetitive surge peak on-state current for a sinusoidal pulse with width :  $t \leq 10$  ms, and corresponding value of  $I^2t$ .

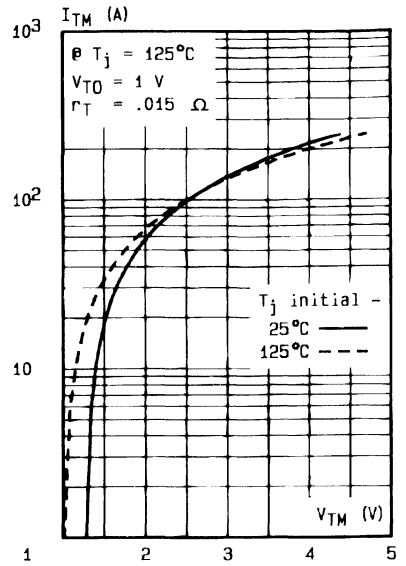

Fig.8 - On-state characteristics (maximum values).



**TRIACS**

- GLASS PASSIVATED CHIP
- FAST-ON CONNEXIONS
- $I_{GT}$  SPECIFIED IN FOUR QUADRANTS
- INSULATING VOLTAGE 2500 V<sub>RMS</sub>
- UL RECOGNIZED (E81734)

**DESCRIPTION**

This new design of plastic insulated power triacs offers maximum efficiency with maximum ease of mounting.

**ADVANTAGES**

- NO TAPPING REQUIRED FOR FIXING
- EXCELLENT THERMAL IMPEDANCE AND HIGH RELIABILITY CONSTRUCTION

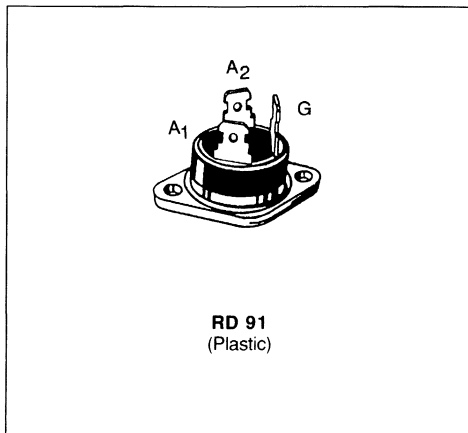
**ABSOLUTE RATINGS** (limiting values)

Symbol	Parameter	Value	Unit
$I_{T(RMS)}$	RMS on-state Current (360° conduction angle)	$T_C - 75\text{ °C}$	A
$I_{TSM}$	Non Repetitive Surge Peak on-state Current ( $T_j$ initial = 25 °C - Half sine wave)	$t = 8.3\text{ ms}$	315
		$t = 10\text{ ms}$	300
$I^2t$	$I^2t$ Value for Fusing	$t = 10\text{ ms}$	A <sup>2</sup> s
$di/dt$	Critical Rate of Rise of on-state Current (1)	Repetitive F = 50 Hz	10
		Non Repetitive	50
$T_{stg}$ $T_j$	Storage and Operating Junction Temperature Range	- 40 to 125	°C
		- 40 to 125	°C

Symbol	Parameter	BTA 40-					Unit
		200A	400A	600A	700A	800A	
$V_{DRM}$	Repetitive Peak off-state Voltage (2)	200	400	600	700	800	V

(1)  $I_G = 1.5\text{ A}$      $di_G/dt = 1\text{ A}/\mu\text{s}$

(2)  $T_j = 125\text{ °C}$ .

**THERMAL RESISTANCES**

Symbol	Parameter	Value	Unit
$R_{th(c-h)}$	Contact (case-heatsink) with Grease	0.15	°C/W
$R_{th(j-c)}\text{ DC}$	Junction to Case for DC	1.2	°C/W
$R_{th(j-c)}\text{ AC}$	Junction to Case for 360 ° Conduction Angle (F = 50 Hz)	0.9	°C/W

**GATE CHARACTERISTICS** (maximum values)

$P_{GM} = 40 \text{ W}$  ( $t_p = 10 \mu\text{s}$ )

$P_{G(AV)} = 1 \text{ W}$

$I_{GM} = 10 \text{ A}$  ( $t_p = 10 \mu\text{s}$ )

$V_{GM} = 16 \text{ V}$  ( $t_p = 10 \mu\text{s}$ )

**ELECTRICAL CHARACTERISTICS**

Symbol	Test Conditions			Quadrants	Min.	Typ.	Max.	Unit
$I_{GT}$	$T_j = 25 \text{ }^\circ\text{C}$ Pulse Duration > 20 $\mu\text{s}$	$V_D = 12 \text{ V}$	$R_L = 33 \text{ } \Omega$	I-II-III	1		100	mA
				IV	1		150	
$V_{GT}$	$T_j = 25 \text{ }^\circ\text{C}$ Pulse Duration > 20 $\mu\text{s}$	$V_D = 12 \text{ V}$	$R_L = 33 \text{ } \Omega$	I-II-III-IV			1.5	V
$V_{GD}$	$T_j = 125 \text{ }^\circ\text{C}$	$V_D = V_{DRM}$	$R_L = 3.3 \text{ k}\Omega$	I-II-III-IV	0.2			V
$I_H^*$	$T_j = 25 \text{ }^\circ\text{C}$	$I_T = 500 \text{ mA}$	Gate Open			30	100	mA
$I_L$	$T_j = 25 \text{ }^\circ\text{C}$ Pulse Duration > 20 $\mu\text{s}$	$V_D = 12 \text{ V}$	$I_G = 300 \text{ mA}$	I-II-III-IV			150	mA
$V_{TM}^*$	$T_j = 25 \text{ }^\circ\text{C}$	$I_{TM} = 60 \text{ A}$	$t_p = 10 \text{ ms}$				1.8	V
$I_{DRM}^*$	$T_j = 125 \text{ }^\circ\text{C}$	$V_{DRM}$ Specified				1.5	6	mA
$dv/dt^*$	$T_j = 125 \text{ }^\circ\text{C}$ Linear Slope up to $V_D = 67\% V_{DRM}$	Gate Open			250			V/ $\mu\text{s}$
$(dv/dt)_C^*$	$T_C = 75 \text{ }^\circ\text{C}$ $(di/dt)_C = 18 \text{ A/ms}$	$V_D = V_{DRM}$	$I_T = 60 \text{ A}$		10			V/ $\mu\text{s}$
$t_{gt}$	$T_j = 25 \text{ }^\circ\text{C}$	$V_D = V_{DRM}$	$I_T = 60 \text{ A}$	I-II-III-IV		2.5		$\mu\text{s}$
		$I_G = 1 \text{ A}$	$di_G/dt = 10 \text{ A}/\mu\text{s}$					

\* For either polarity of electrode  $A_2$  voltage with reference to electrode  $A_1$ .

**PACKAGE MECHANICAL DATA : RD 91 Plastic**

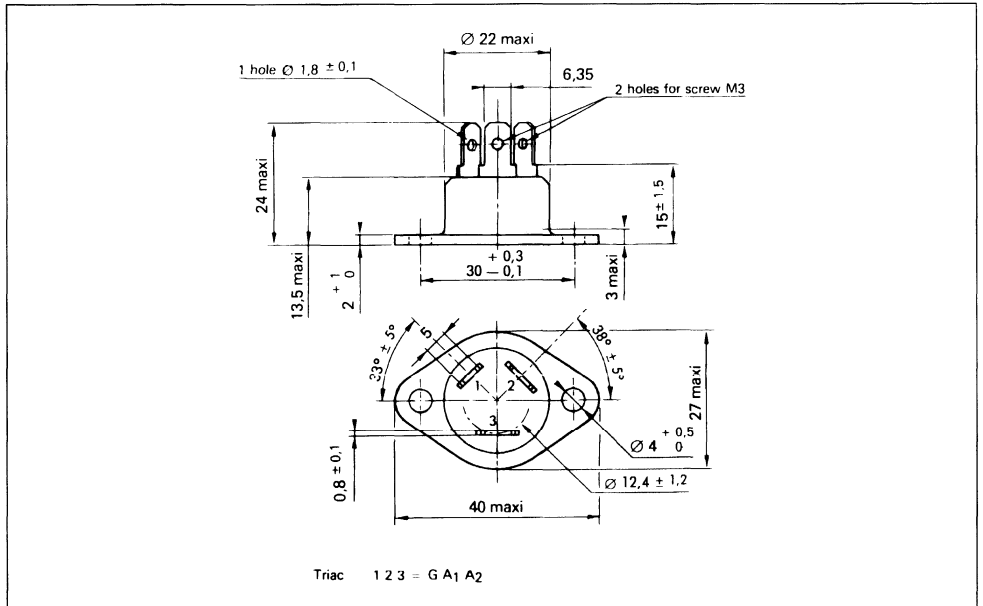

Cooling method : by conduction (method C)

Marking : type number

Weight : 15 g

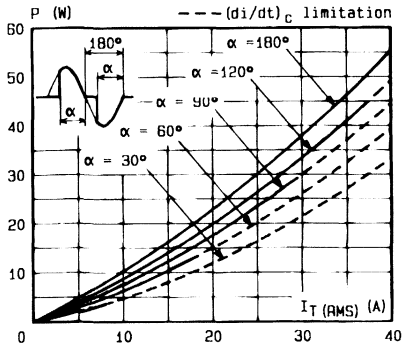

Fig. 1 - Maximum mean power dissipation versus RMS on-state current ( $F = 60$  Hz).

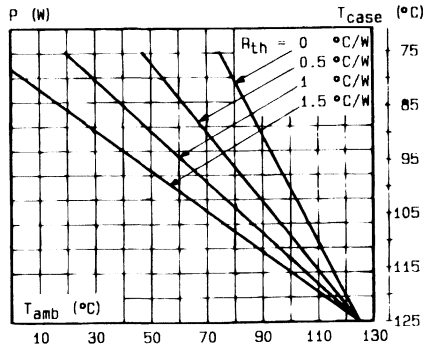

Fig. 2 - Correlation between maximum mean power dissipation and maximum allowable temperatures ( $T_{amb}$  and  $T_{case}$ ) for different thermal resistances heatsink + contact.

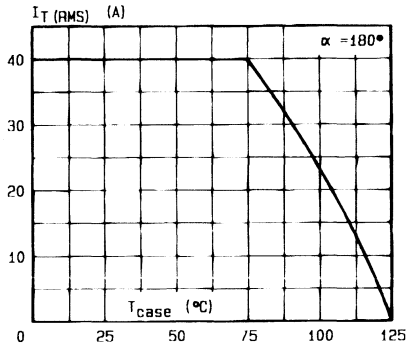

Fig. 3 - RMS on-state current versus case temperature.

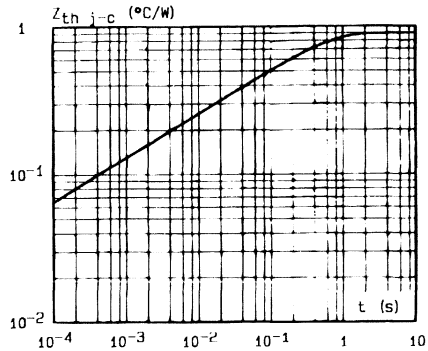

Fig. 4 - Thermal transient impedance junction to case versus pulse duration.

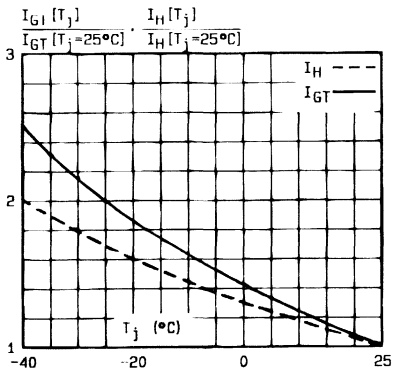

Fig. 5 - Relative variation of gate trigger current and holding current versus junction temperature.

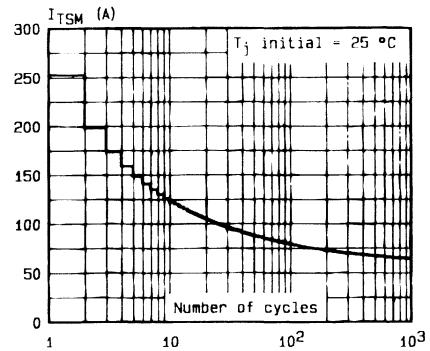

Fig. 6 - Non repetitive surge peak on-state current versus number of cycles.

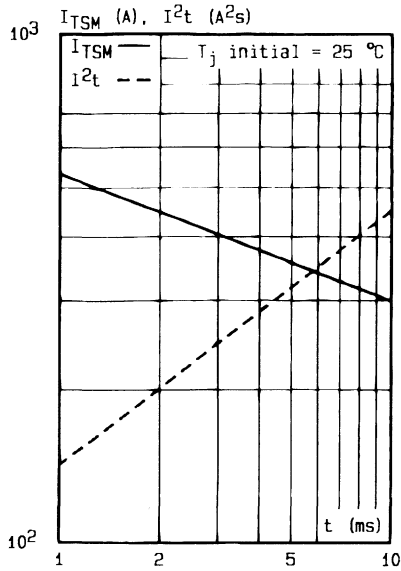

Fig.7 - Non repetitive surge peak on-state current for a sinusoidal pulse with width :  $t \leq 10$  ms, and corresponding value of  $I^2t$ .

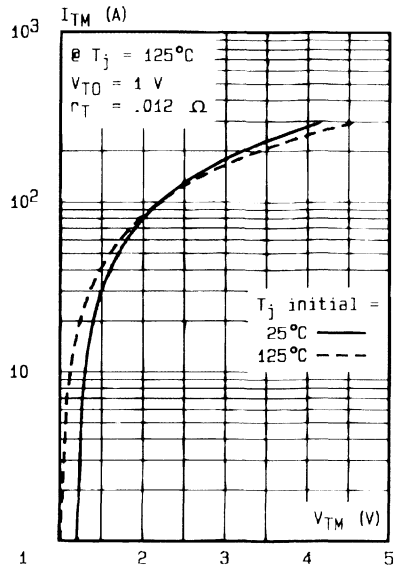

Fig.8 - On-state characteristics (maximum values) .

**TRIACS**

- GLASS PASSIVATED CHIP
- FAST-ON CONNEXIONS
- I<sub>GT</sub> SPECIFIED IN FOUR QUADRANTS
- INSULATING VOLTAGE 2500 V<sub>RMS</sub>
- UL RECOGNIZED (E81734)

**DESCRIPTION**

This new design of plastic insulated power triacs offers maximum efficiency with maximum ease of mounting.

**ADVANTAGES**

- NO TAPPING REQUIRED FOR FIXING
- EXCELLENT THERMAL IMPEDANCE AND HIGH RELIABILITY CONSTRUCTION

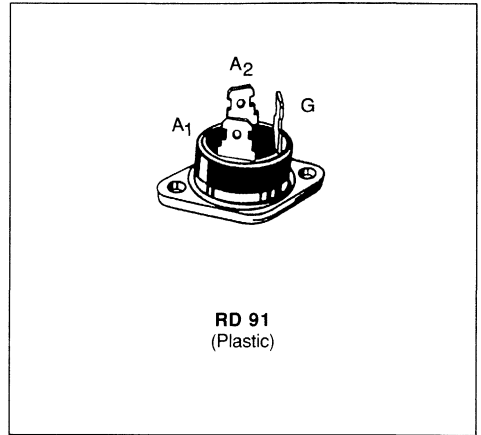
**ABSOLUTE RATINGS** (limiting values)

Symbol	Parameter	Value	Unit
I <sub>T(RMS)</sub>	RMS on-state Current (360° conduction angle) T <sub>C</sub> = 75 °C	40	A
I <sub>TSM</sub>	Non Repetitive Surge Peak on-state Current (T <sub>j</sub> initial = 25 °C - Half sine wave)	t = 8.3 ms	315
		t = 10 ms	300
I <sup>2</sup> t	I <sup>2</sup> t Value for Fusing t = 10 ms	450	A <sup>2</sup> s
di/dt	Critical Rate of Rise of on-state Current (1)	Repetitive F = 50 Hz	10
		Non Repetitive	50
T <sub>stg</sub> T <sub>j</sub>	Storage and Operating Junction Temperature Range	- 40 to 125	°C
		- 40 to 125	°C

Symbol	Parameter	BTA 40-					Unit
		200B	400B	600B	700B	800B	
V <sub>DRM</sub>	Repetitive Peak off-state Voltage (2)	200	400	600	700	800	V

(1) I<sub>G</sub> = 1 A di<sub>G</sub>/dt = 1 A/μs

(2) T<sub>j</sub> = 125 °C.

**THERMAL RESISTANCES**

Symbol	Parameter	Value	Unit
R <sub>th (c-h)</sub>	Contact (case-heatsink) with Grease	0.15	°C/W
R <sub>th (j-c) DC</sub>	Junction to Case for DC	1.2	°C/W
R <sub>th (j-c) AC</sub>	Junction to Case for 360 ° Conduction Angle (F = 50 Hz)	0.9	°C/W



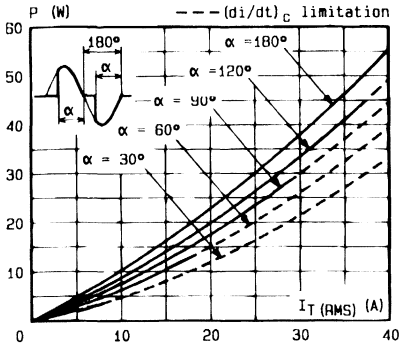

Fig. 1 - Maximum mean power dissipation versus RMS on-state current (F = 60 Hz).

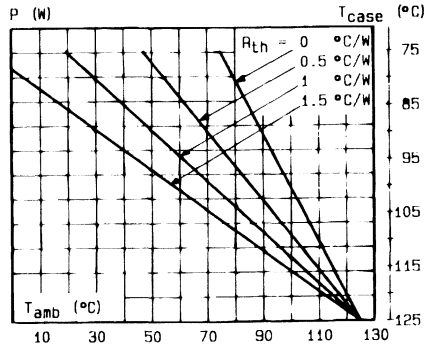

Fig. 2 - Correlation between maximum mean power dissipation and maximum allowable temperatures (T<sub>amb</sub> and T<sub>case</sub>) for different thermal resistances heatsink + contact.

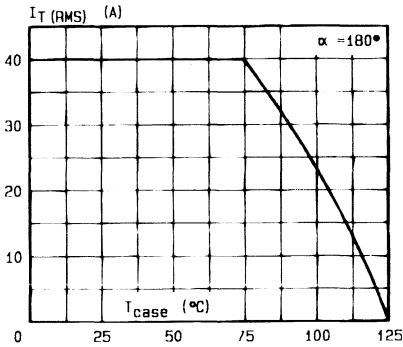

Fig. 3 - RMS on-state current versus case temperature.

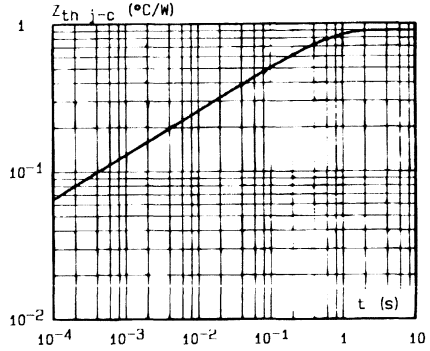

Fig. 4 - Thermal transient impedance junction to case versus pulse duration.

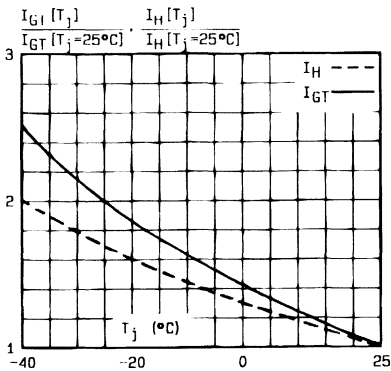

Fig. 5 - Relative variation of gate trigger current and holding current versus junction temperature.

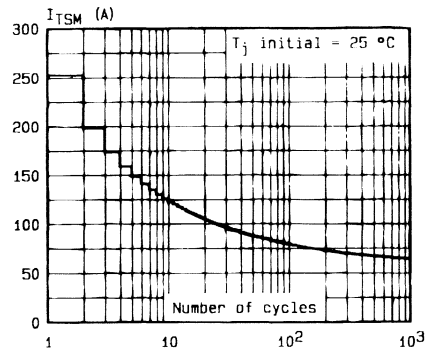

Fig. 6 - Non repetitive surge peak on-state current versus number of cycles.

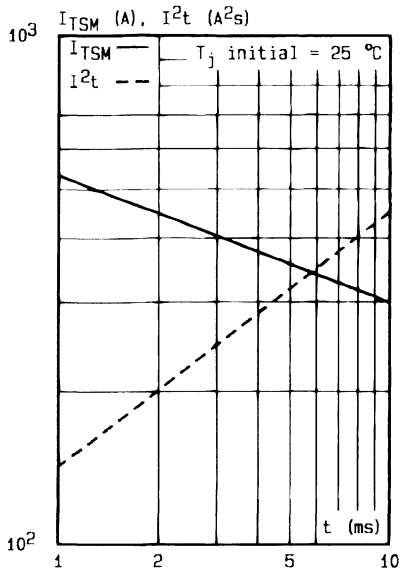

Fig.7 - Non repetitive surge peak on-state current for a sinusoidal pulse with width :  $t \leq 10$  ms, and corresponding value of  $I^2t$ .

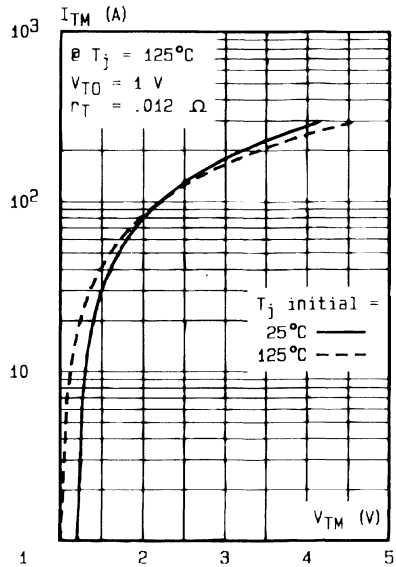

Fig.8 - On-state characteristics (maximum values).



## TRIACS

- GLASS PASSIVATED CHIP
- $I_{GT}$  SPECIFIED IN FOUR QUADRANTS
- INSULATING VOLTAGE 2500  $V_{RMS}$
- UL RECOGNIZED (E81734)

### DESCRIPTION

This new design of plastic insulated power triacs offers maximum efficiency with maximum ease of mounting.

### ADVANTAGES

- NO TAPPING REQUIRED FOR FIXING
- EXCELLENT THERMAL IMPEDANCE AND HIGH RELIABILITY CONSTRUCTION

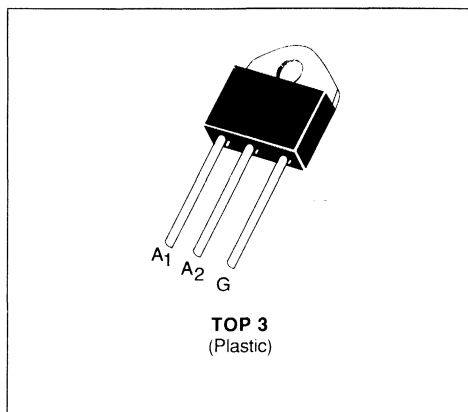

### ABSOLUTE RATINGS (limiting values)

Symbol	Parameter	Value	Unit	
$I_{T(RMS)}$	RMS on-state Current (360° conduction angle)	$T_C = 75\text{ }^\circ\text{C}$ 40	A	
$I_{TSM}$	Non Repetitive Surge Peak on-state Current ( $T_j$ initial = 25 °C - Half sine wave)	$t = 8.3\text{ ms}$	315	A
		$t = 10\text{ ms}$	300	
$I^2t$	$I^2t$ Value for Fusing	$t = 10\text{ ms}$	450	A <sup>2</sup> s
$di/dt$	Critical Rate of Rise of on-state Current (1)	Repetitive $F = 50\text{ Hz}$	10	A/ $\mu$ s
		Non Repetitive	50	
$T_{stg}$ $T_j$	Storage and Operating Junction Temperature Range	- 40 to 125 - 40 to 125	$^\circ\text{C}$ $^\circ\text{C}$	

Symbol	Parameter	BTA 41-					Unit
		200A	400A	600A	700A	800A	
$V_{DRM}$	Repetitive Peak off-state Voltage (2)	200	400	600	700	800	V

(1)  $I_G = 1.5\text{ A}$   $di/dt = 1\text{ A}/\mu\text{s}$

(2)  $T_j = 125\text{ }^\circ\text{C}$ .

### THERMAL RESISTANCES

Symbol	Parameter	Value	Unit
$R_{th(j-a)}$	Junction to Ambient	50	$^\circ\text{C}/\text{W}$
$R_{th(c-h)}$	Contact (case-heatsink) with Grease	0.2	$^\circ\text{C}/\text{W}$
$R_{th(j-c)}$ DC	Junction to Case for DC	1.2	$^\circ\text{C}/\text{W}$
$R_{th(j-c)}$ AC	Junction to Case for 360 ° Conduction Angle ( $F = 50\text{ Hz}$ )	0.9	$^\circ\text{C}/\text{W}$

**GATE CHARACTERISTICS** (maximum values)

$P_{GM} = 40 \text{ W}$  ( $t_p = 10 \mu\text{s}$ )       $I_{GM} = 10 \text{ A}$  ( $t_p = 10 \mu\text{s}$ )  
 $P_{G(AV)} = 1 \text{ W}$        $V_{GM} = 16 \text{ V}$  ( $t_p = 10 \mu\text{s}$ )

**ELECTRICAL CHARACTERISTICS**

Symbol	Test Conditions			Quadrants	Min.	Typ.	Max.	Unit
$I_{GT}$	$T_j = 25 \text{ }^\circ\text{C}$ Pulse Duration > 20 $\mu\text{s}$	$V_D = 12 \text{ V}$	$R_L = 33 \text{ } \Omega$	I-II-III	1		100	mA
				IV	1		150	
$V_{GT}$	$T_j = 25 \text{ }^\circ\text{C}$ Pulse Duration > 20 $\mu\text{s}$	$V_D = 12 \text{ V}$	$R_L = 33 \text{ } \Omega$	I-II-III-IV			1.5	V
$V_{GD}$	$T_j = 125 \text{ }^\circ\text{C}$	$V_D = V_{DRM}$	$R_L = 3.3 \text{ k}\Omega$	I-II-III-IV	0.2			V
$I_{H}^*$	$T_j = 25 \text{ }^\circ\text{C}$	$I_T = 500 \text{ mA}$	Gate Open			30	100	mA
$I_L$	$T_j = 25 \text{ }^\circ\text{C}$ Pulse Duration > 20 $\mu\text{s}$	$V_D = 12 \text{ V}$	$I_G = 300 \text{ mA}$	I-II-III-IV			150	mA
$V_{TM}^*$	$T_j = 25 \text{ }^\circ\text{C}$	$I_{TM} = 60 \text{ A}$	$t_p = 10 \text{ ms}$				1.8	V
$I_{DRM}^*$	$T_j = 125 \text{ }^\circ\text{C}$	$V_{DRM}$ Specified				1.5	6	mA
$dv/dt^*$	$T_j = 125 \text{ }^\circ\text{C}$	Gate Open Linear Slope up to $V_D = 67\% V_{DRM}$			250			V/ $\mu\text{s}$
$(dv/dt)_c^*$	$T_C = 75 \text{ }^\circ\text{C}$ $(di/dt)_c = 18 \text{ A/ms}$	$V_D = V_{DRM}$	$I_T = 60 \text{ A}$		10			V/ $\mu\text{s}$
$t_{gt}$	$T_j = 25 \text{ }^\circ\text{C}$ $I_G = 1 \text{ A}$	$V_D = V_{DRM}$ $di_G/dt = 10 \text{ A}/\mu\text{s}$	$I_T = 60 \text{ A}$	I-II-III-IV		2.5		$\mu\text{s}$

\* For either polarity of electrode  $A_2$  voltage with reference to electrode  $A_1$ .

**PACKAGE MECHANICAL DATA**

TOP 3 Plastic

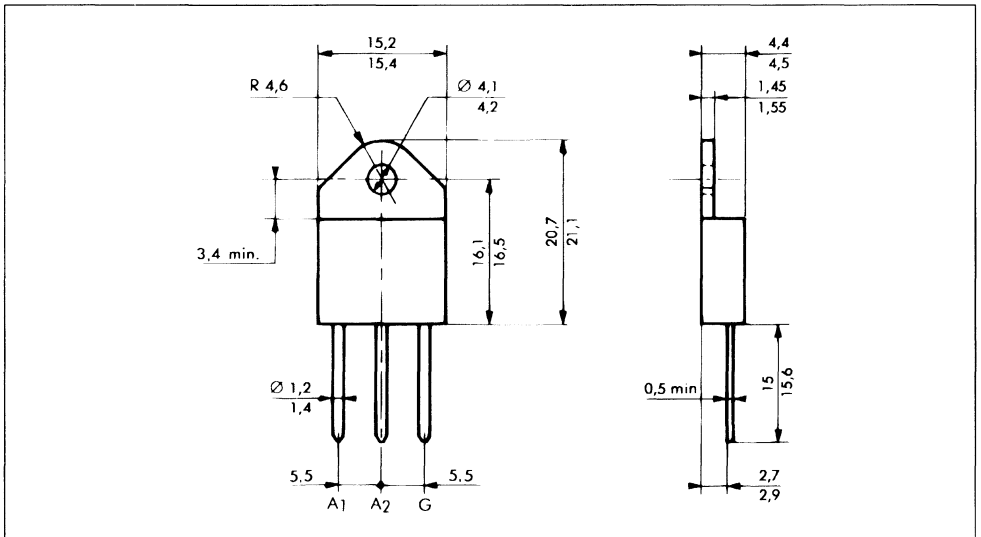

Cooling method : by conduction (method C)  
 Marking : type number  
 Weight : 5 g

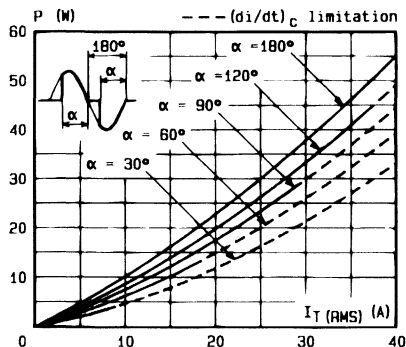

Fig.1 - Maximum mean power dissipation versus RMS on-state current ( $F = 60$  Hz).

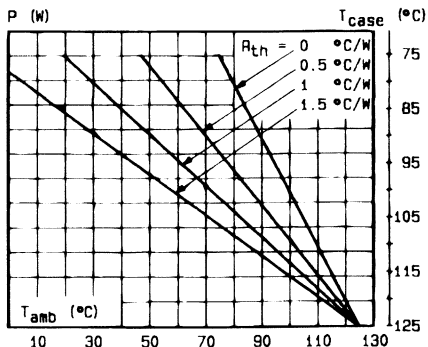

Fig.2 - Correlation between maximum mean power dissipation and maximum allowable temperatures ( $T_{amb}$  and  $T_{case}$ ) for different thermal resistances heatsink + contact.

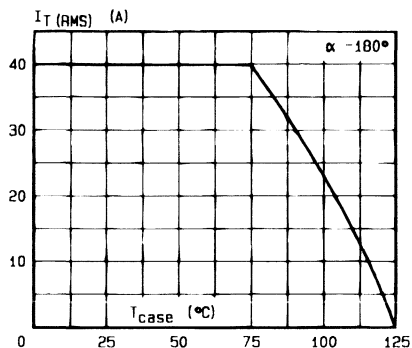

Fig.3 - RMS on-state current versus case temperature.

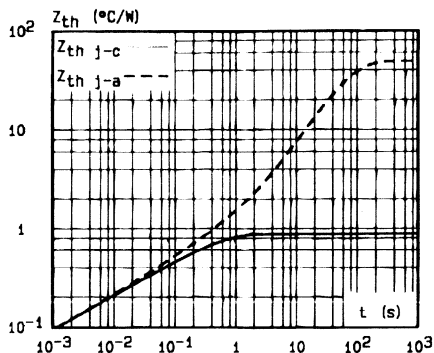

Fig.4 - Thermal transient impedance junction to case and junction to ambient versus pulse duration.

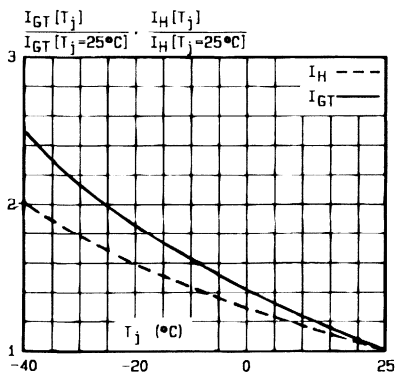

Fig.5 - Relative variation of gate trigger current and holding current versus junction temperature.

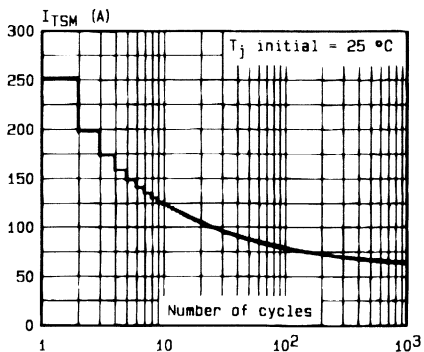

Fig.6 - Non repetitive surge peak on-state current versus number of cycles.

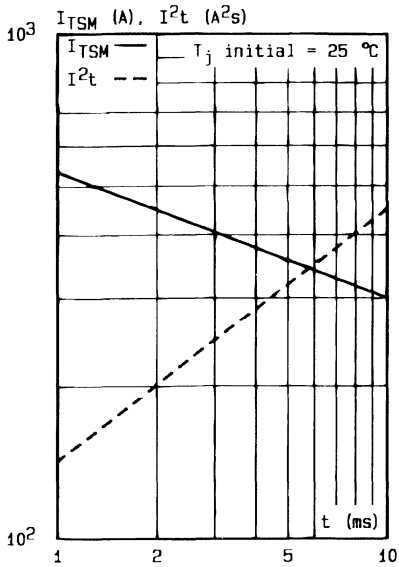

Fig.7 - Non repetitive surge peak on-state current for a sinusoidal pulse with width :  $t \leq 10$  ms, and corresponding value of  $I^2t$ .

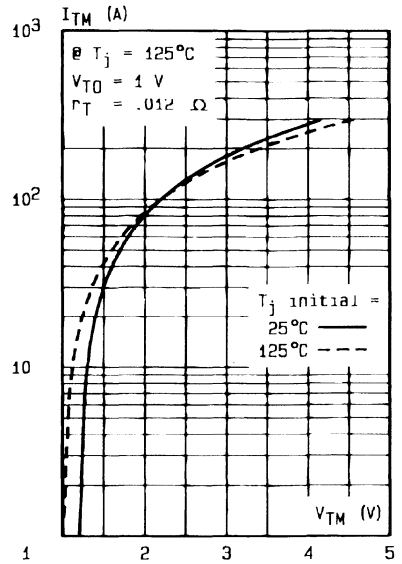

Fig.8 - On-state characteristics (maximum values).

## TRIACS

- GLASS PASSIVATED CHIP
- $I_{GT}$  SPECIFIED IN FOUR QUADRANTS
- INSULATING VOLTAGE 2500  $V_{RMS}$
- UL RECOGNIZED (E81734)

### DESCRIPTION

This new design of plastic insulated power triacs offers maximum efficiency with maximum ease of mounting.

### ADVANTAGES

- NO TAPPING REQUIRED FOR FIXING
- EXCELLENT THERMAL IMPEDANCE AND HIGH RELIABILITY CONSTRUCTION

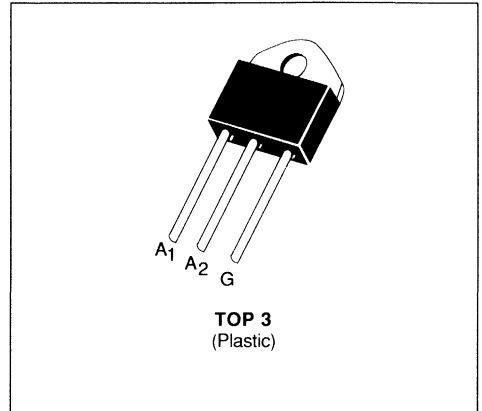

### ABSOLUTE RATINGS (limiting values)

Symbol	Parameter	Value	Unit
$I_{T(RMS)}$	RMS on-state Current (360° conduction angle)	$T_C = 75\text{ }^\circ\text{C}$ 40	A
$I_{TSM}$	Non Repetitive Surge Peak on-state Current ( $T_j$ initial = 25 °C - Half sine wave)	$t = 8.3\text{ ms}$	315
		$t = 10\text{ ms}$	300
$I^2t$	$I^2t$ Value for Fusing	$t = 10\text{ ms}$	$A^2s$
di/dt	Critical Rate of Rise of on-state Current (1)	Repetitive $F = 50\text{ Hz}$	10
		Non Repetitive	50
$T_{stg}$ $T_j$	Storage and Operating Junction Temperature Range	- 40 to 125 - 40 to 125	$^\circ\text{C}$ $^\circ\text{C}$

Symbol	Parameter	BTA 41-					Unit
		200B	400B	600B	700B	800B	
$V_{DRM}$	Repetitive Peak off-state Voltage (2)	200	400	600	700	800	V

(1)  $I_G = 1\text{ A}$   $di/dt = 1\text{ A}/\mu\text{s}$

(2)  $T_j = 125\text{ }^\circ\text{C}$ .

### THERMAL RESISTANCES

Symbol	Parameter	Value	Unit
$R_{th(j-a)}$	Junction to Ambient	50	$^\circ\text{C}/\text{W}$
$R_{th(c-h)}$	Contact (case-heatsink) with Grease	0.2	$^\circ\text{C}/\text{W}$
$R_{th(j-c)}\text{ DC}$	Junction to Case for DC	1.2	$^\circ\text{C}/\text{W}$
$R_{th(j-c)}\text{ AC}$	Junction to Case for 360 ° Conduction Angle ( $F = 50\text{ Hz}$ )	0.9	$^\circ\text{C}/\text{W}$

**GATE CHARACTERISTICS** (maximum values)

$P_{GM} = 40 \text{ W}$  ( $t_p = 10 \mu\text{s}$ )       $I_{GM} = 10 \text{ A}$  ( $t_p = 10 \mu\text{s}$ )  
 $P_{G(AV)} = 1 \text{ W}$        $V_{GM} = 16 \text{ V}$  ( $t_p = 10 \mu\text{s}$ )

**ELECTRICAL CHARACTERISTICS**

Symbol	Test Conditions			Quadrants	Min.	Typ.	Max.	Unit
$I_{GT}$	$T_j = 25 \text{ }^\circ\text{C}$ Pulse Duration > 20 $\mu\text{s}$	$V_D = 12 \text{ V}$	$R_L = 33 \text{ } \Omega$	I-II-III	1		50	mA
				IV	1		100	
$V_{GT}$	$T_j = 25 \text{ }^\circ\text{C}$ Pulse Duration > 20 $\mu\text{s}$	$V_D = 12 \text{ V}$	$R_L = 33 \text{ } \Omega$	I-II-III-IV			1.5	V
$V_{GD}$	$T_j = 125 \text{ }^\circ\text{C}$	$V_D = V_{DRM}$	$R_L = 3.3 \text{ k}\Omega$	I-II-III-IV	0.2			V
$I_H^*$	$T_j = 25 \text{ }^\circ\text{C}$	$I_T = 500 \text{ mA}$	Gate Open			30	80	mA
$I_L$	$T_j = 25 \text{ }^\circ\text{C}$ Pulse Duration > 20 $\mu\text{s}$	$V_D = 12 \text{ V}$	$I_G = 200 \text{ mA}$	I-II-III-IV			100	mA
$V_{TM}^*$	$T_j = 25 \text{ }^\circ\text{C}$	$I_{TM} = 60 \text{ A}$	$t_p = 10 \text{ ms}$				1.8	V
$I_{DRM}^*$	$T_j = 125 \text{ }^\circ\text{C}$	$V_{DRM}$ Specified				1.5	6	mA
$dv/dt^*$	$T_j = 125 \text{ }^\circ\text{C}$	Gate Open Linear Slope up to $V_D = 67 \% V_{DRM}$			250			V/ $\mu\text{s}$
$(dv/dt)_c^*$	$T_C = 75 \text{ }^\circ\text{C}$	$V_D = V_{DRM}$	$I_T = 60 \text{ A}$ $(di/dt)_c = 18 \text{ A/ms}$		5			V/ $\mu\text{s}$
$t_{gt}$	$T_j = 25 \text{ }^\circ\text{C}$ $I_G = 1 \text{ A}$	$V_D = V_{DRM}$	$I_T = 60 \text{ A}$ $di_G/dt = 10 \text{ A}/\mu\text{s}$	I-II-III-IV		2.5		$\mu\text{s}$

\* For either polarity of electrode  $A_2$  voltage with reference to electrode  $A_1$ .

**PACKAGE MECHANICAL DATA**

TOP 3 Plastic

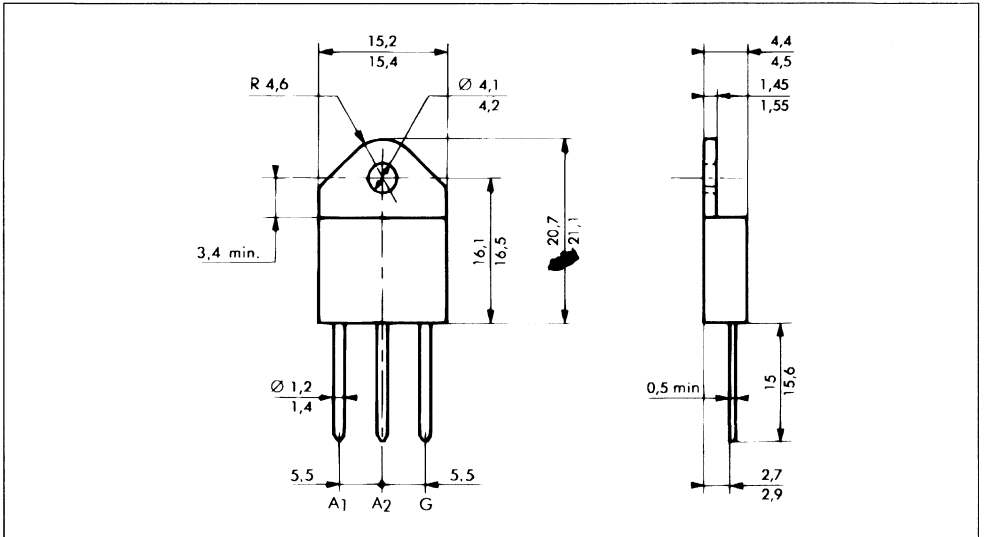

Cooling method : by conduction (method C)  
 Marking : type number  
 Weight : 5 g

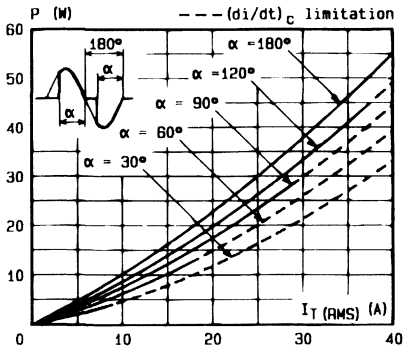

Fig.1 - Maximum mean power dissipation versus RMS on-state current (F = 60 Hz).

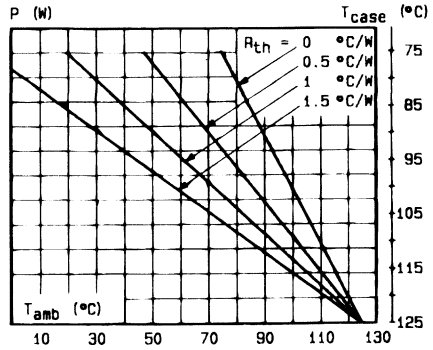

Fig.2 - Correlation between maximum mean power dissipation and maximum allowable temperatures (T<sub>amb</sub> and T<sub>case</sub>) for different thermal resistances heatsink + contact.

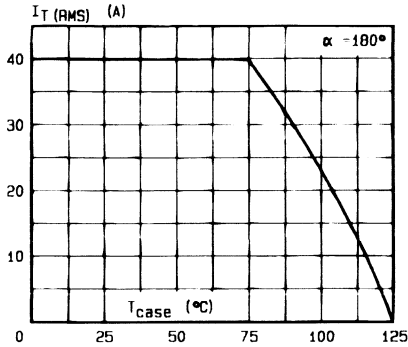

Fig.3 - RMS on-state current versus case temperature.

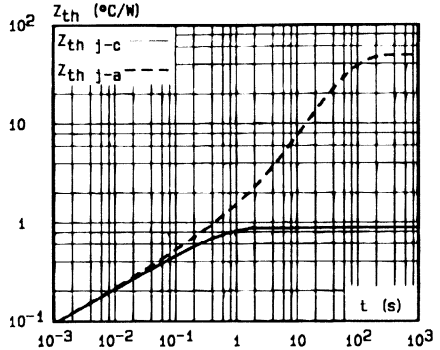

Fig.4 - Thermal transient impedance junction to case and junction to ambient versus pulse duration.

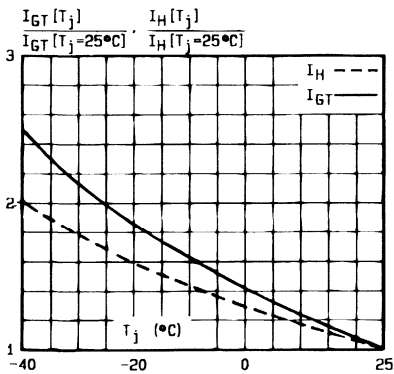

Fig.5 - Relative variation of gate trigger current and holding current versus junction temperature.

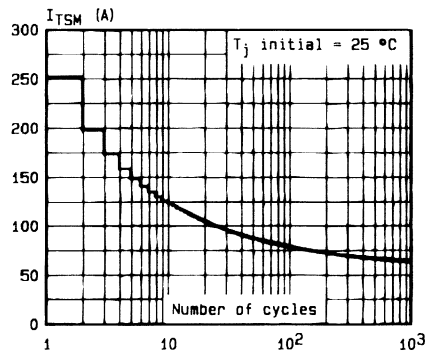

Fig.6 - Non repetitive surge peak on-state current versus number of cycles.

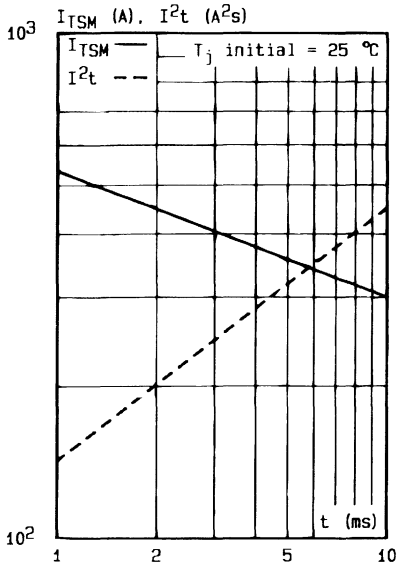

Fig. 7 - Non repetitive surge peak on-state current for a sinusoidal pulse with width :  $t \leq 10$  ms, and corresponding value of  $I^2t$ .

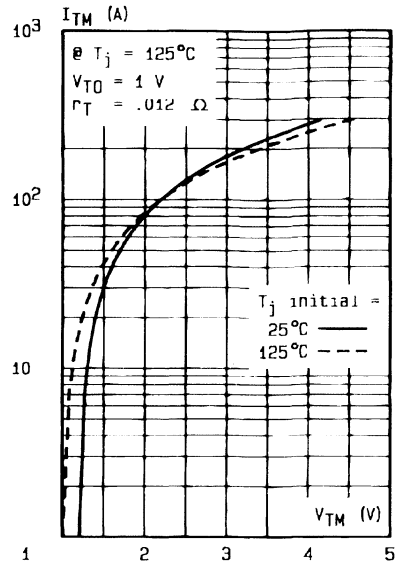
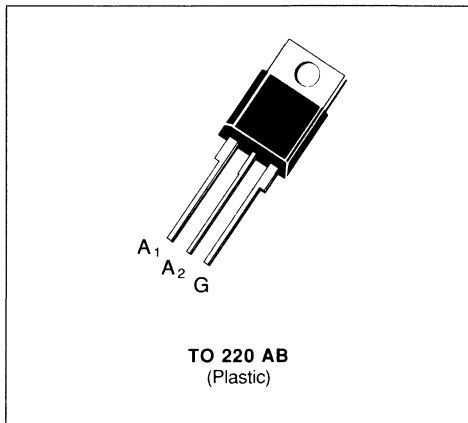

Fig. 8 - On-state characteristics (maximum values).



**SENSITIVE GATE TRIACS**

- GLASS PASSIVATED CHIP
- $I_{GT}$  SPECIFIED IN FOUR QUADRANTS
- AVAILABLE IN INSULATED VERSION → BTA SERIES (INSULATING VOLTAGE 2500  $V_{RMS}$ ) OR IN UNINSULATED VERSION → BTB SERIES
- UL RECOGNIZED FOR BTA SERIES (E81734)

**DESCRIPTION**

New range suited for applications such as phase control and static switching.

**ABSOLUTE RATINGS** (limiting values)

Symbol	Parameter	Value	Unit	
$I_{T(RMS)}$	RMS on-state Current (360° conduction angle)	$T_C = 75\text{ °C}$ 4	A	
$I_{TSM}$	Non Repetitive Surge Peak on-state Current ( $T_j$ initial = 25 °C - Half sine wave)	$t = 8.3\text{ ms}$	52	A
		$t = 10\text{ ms}$	50	
$I^2t$	$I^2t$ Value for Fusing	$t = 10\text{ ms}$	12.5	A <sup>2</sup> s
di/dt	Critical Rate of Rise of on-state Current (1)	Repetitive $F = 50\text{ Hz}$	10	A/ $\mu$ s
		Non Repetitive	50	
$T_{stg}$ $T_j$	Storage and Operating Junction Temperature Range	- 40 to 150		°C
		- 40 to 110		°C

Symbol	Parameter	BTA/BTB 04-					Unit
		200A	400A	600A	700A	800A	
$V_{DRM}$	Repetitive Peak off-state Voltage (2)	200	400	600	700	800	V

(1)  $I_G = 250\text{ mA}$      $di_G/dt = 1\text{ A}/\mu\text{s}$

(2)  $T_j = 110\text{ °C}$ .

**THERMAL RESISTANCES**

Symbol	Parameter	Value	Unit
$R_{th(j-a)}$	Junction to Ambient	60	°C/W
$R_{th(j-c)}\text{ DC}$	Junction to Case for DC	8.7	°C/W
$R_{th(j-c)}\text{ AC}$	Junction to Case for 360 ° Conduction Angle ( $F = 50\text{ Hz}$ )	6.5	°C/W

**GATE CHARACTERISTICS** (maximum values)

$P_{GM} = 40 \text{ W}$  ( $t_p = 10 \mu\text{s}$ )

$I_{GM} = 4 \text{ A}$  ( $t_p = 10 \mu\text{s}$ )

$P_{G(AV)} = 1 \text{ W}$

$V_{GM} = 16 \text{ V}$  ( $t_p = 10 \mu\text{s}$ )

**ELECTRICAL CHARACTERISTICS**

Symbol	Test Conditions	Quadrants	Min.	Typ.	Max.	Unit
$I_{GT}$	$T_j = 25 \text{ }^\circ\text{C}$ $V_D = 12 \text{ V}$ $R_L = 33 \Omega$ Pulse Duration > 20 $\mu\text{s}$	I-II-III			10	mA
		IV			25	
$V_{GT}$	$T_j = 25 \text{ }^\circ\text{C}$ $V_D = 12 \text{ V}$ $R_L = 33 \Omega$ Pulse Duration > 20 $\mu\text{s}$	I-II-III-IV			1.5	V
$V_{GD}$	$T_j = 110 \text{ }^\circ\text{C}$ $V_D = V_{DRM}$ $R_L = 3.3 \text{ k}\Omega$	I-II-III-IV	0.2			V
$I_H^*$	$T_j = 25 \text{ }^\circ\text{C}$ $I_T = 100 \text{ mA}$ Gate Open				25	mA
$I_L$	$T_j = 25 \text{ }^\circ\text{C}$ $V_D = 12 \text{ V}$ $I_G = 50 \text{ mA}$ Pulse Duration > 20 $\mu\text{s}$	I-III-IV		25		mA
		II		50		
$V_{TM}^*$	$T_j = 25 \text{ }^\circ\text{C}$ $I_{TM} = 5.5 \text{ A}$ $t_p = 10 \text{ ms}$				1.65	V
$I_{DRM}^*$	$V_{DRM}$ Specified				0.01	mA
					0.75	
$dv/dt^*$	$T_j = 110 \text{ }^\circ\text{C}$ Gate Open Linear Slope up to $V_D = 67\% V_{DRM}$		10			V/ $\mu\text{s}$
$(dv/dt)_c^*$	$T_C = 75 \text{ }^\circ\text{C}$ $V_D = V_{DRM}$ $I_T = 5.5 \text{ A}$ $(di/dt)_c = 1.8 \text{ A/ms}$			5		V/ $\mu\text{s}$
$t_{gt}$	$T_j = 25 \text{ }^\circ\text{C}$ $V_D = V_{DRM}$ $I_T = 5.5 \text{ A}$ $I_G = 40 \text{ mA}$ $di_G/dt = 0.45 \text{ A}/\mu\text{s}$	I-II-III-IV		2		$\mu\text{s}$

\* For either polarity of electrode  $A_2$  voltage with reference to electrode  $A_1$ .

**PACKAGE MECHANICAL DATA**

TO 220 AB Plastic

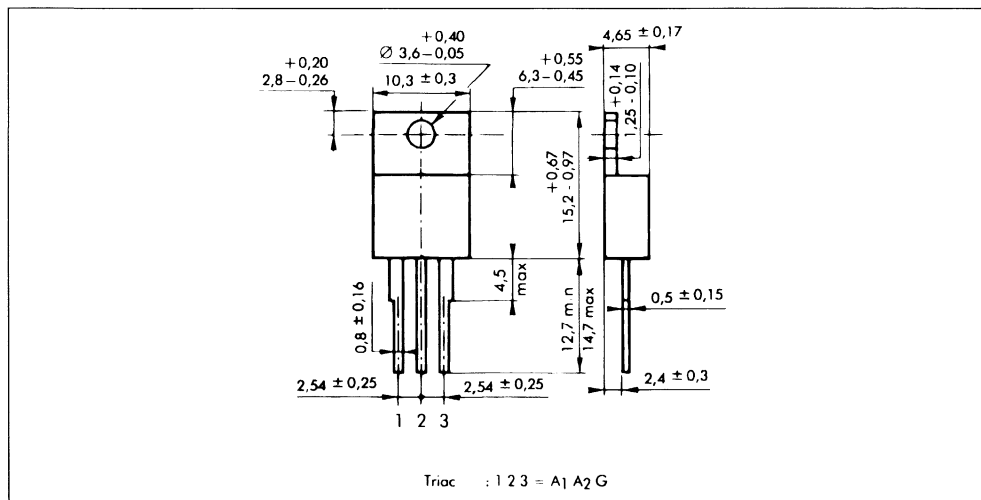

Cooling method : by conduction (method C)

Marking : type number

Weight : 2 g.

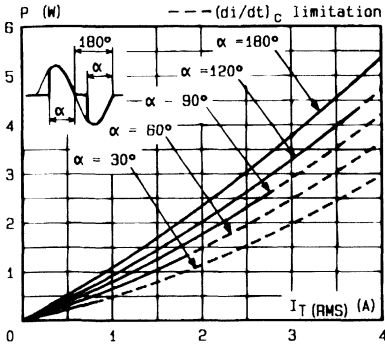

Fig. 1 - Maximum mean power dissipation versus RMS on-state current (F = 60 Hz).

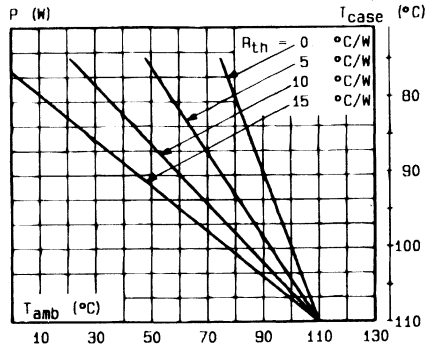

Fig. 2 - Correlation between maximum mean power dissipation and maximum allowable temperatures ( $T_{amb}$  and  $T_{case}$ ) for different thermal resistances heatsink + contact.

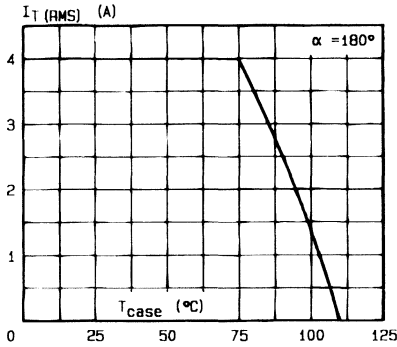

Fig. 3 - RMS on-state current versus case temperature.

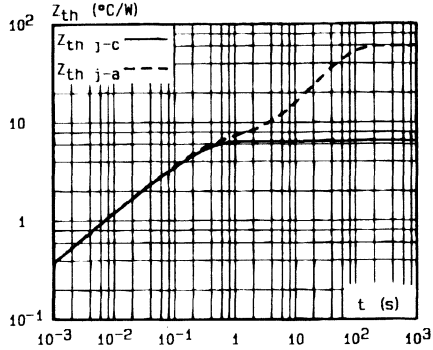

Fig. 4 - Thermal transient impedance junction to case and junction to ambient versus pulse duration.

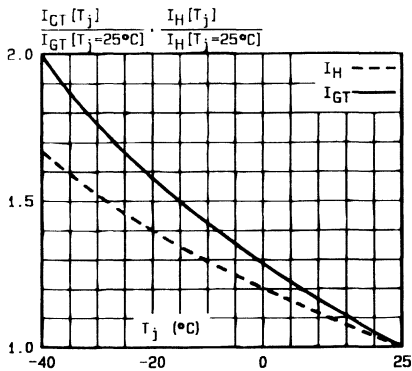

Fig. 5 - Relative variation of gate trigger current and holding current versus junction temperature.

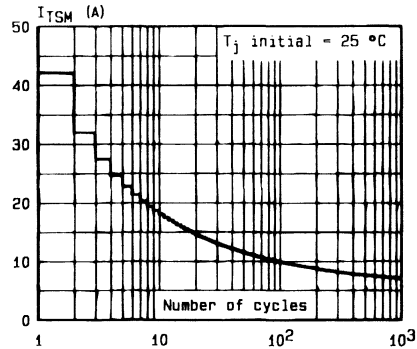

Fig. 6 - Non repetitive surge peak on-state current versus number of cycles.

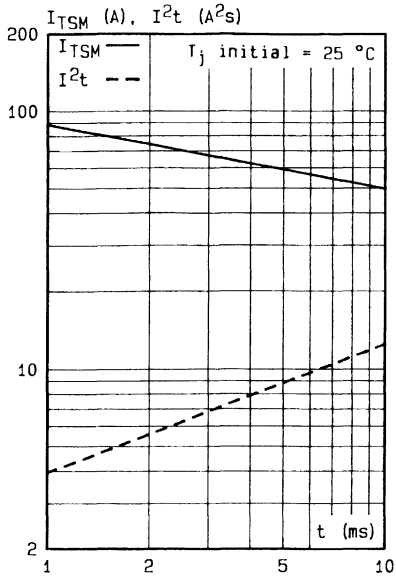

Fig.7 - Non repetitive surge peak on-state current for a sinusoidal pulse with width :  $t \leq 10$  ms, and corresponding value of  $I^2t$ .

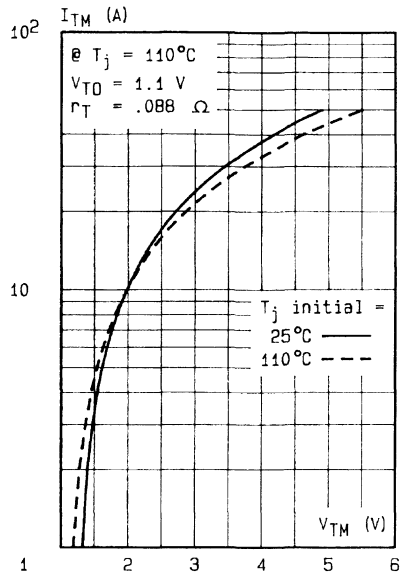
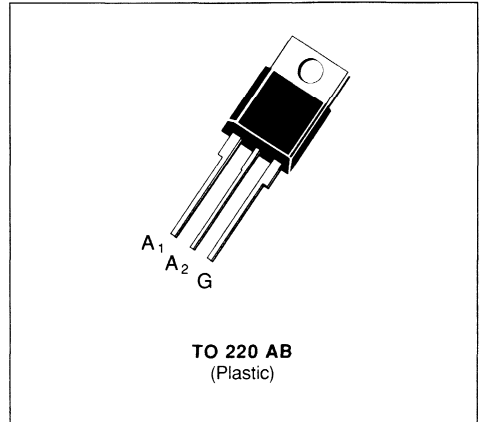

Fig.8 - On-state characteristics (maximum values).

**SENSITIVE GATE TRIACS**

- GLASS PASSIVATED CHIP
- $I_{GT}$  SPECIFIED IN FOUR QUADRANTS
- AVAILABLE IN INSULATED VERSION → BTA SERIES (INSULATING VOLTAGE 2500 V<sub>RMS</sub>) OR IN UNINSULATED VERSION → BTB SERIES
- UL RECOGNIZED FOR BTA SERIES (E81734)

**DESCRIPTION**

New range suited for applications such as phase control and static switching.

**ABSOLUTE RATINGS** (limiting values)

Symbol	Parameter	Value	Unit
$I_{T(RMS)}$	RMS on-state Current (360° conduction angle)	$T_C = 75\text{ °C}$ 4	A
$I_{TSM}$	Non Repetitive Surge Peak on-state Current ( $T_J$ initial = 25 °C - Half sine wave)	$t = 8.3\text{ ms}$	52
		$t = 10\text{ ms}$	50
$I^2t$	$I^2t$ Value for Fusing	$t = 10\text{ ms}$ 12.5	A <sup>2</sup> s
di/dt	Critical Rate of Rise of on-state Current (1)	Repetitive $F = 50\text{ Hz}$	10
		Non Repetitive	50
$T_{stg}$ $T_J$	Storage and Operating Junction Temperature Range	- 40 to 150	°C
		- 40 to 110	°C

Symbol	Parameter	BTA/BTB 04-					Unit
		200D	400D	600D	700D	800D	
$V_{DRM}$	Repetitive Peak off-state Voltage (2)	200	400	600	700	800	V

(1)  $I_G = 100\text{ mA}$   $di_c/dt = 1\text{ A}/\mu\text{s}$

(2)  $T_J = 110\text{ °C}$ .

**THERMAL RESISTANCES**

Symbol	Parameter	Value	Unit
$R_{th(j-a)}$	Junction to Ambient	60	°C/W
$R_{th(j-c)}\text{ DC}$	Junction to Case for DC	8.7	°C/W
$R_{th(j-c)}\text{ AC}$	Junction to Case for 360 ° Conduction Angle ( $F = 50\text{ Hz}$ )	6.5	°C/W

**GATE CHARACTERISTICS** (maximum values)

$P_{GM} = 40 \text{ W}$  ( $t_p = 10 \mu\text{s}$ )       $I_{GM} = 4 \text{ A}$  ( $t_p = 10 \mu\text{s}$ )  
 $P_{G(AV)} = 1 \text{ W}$        $V_{GM} = 16 \text{ V}$  ( $t_p = 10 \mu\text{s}$ )

**ELECTRICAL CHARACTERISTICS**

Symbol	Test Conditions			Quadrants	Min.	Typ.	Max.	Unit
$I_{GT}$	$T_j = 25 \text{ }^\circ\text{C}$ Pulse Duration > 20 $\mu\text{s}$	$V_D = 12 \text{ V}$	$R_L = 33 \text{ } \Omega$	I-II-III			5	mA
				IV			10	
$V_{GT}$	$T_j = 25 \text{ }^\circ\text{C}$ Pulse Duration > 20 $\mu\text{s}$	$V_D = 12 \text{ V}$	$R_L = 33 \text{ } \Omega$	I-II-III-IV			1.5	V
$V_{GD}$	$T_j = 110 \text{ }^\circ\text{C}$	$V_D = V_{DRM}$	$R_L = 3.3 \text{ k}\Omega$	I-II-III-IV	0.2			V
$I_{H^*}$	$T_j = 25 \text{ }^\circ\text{C}$	$I_T = 100 \text{ mA}$	Gate Open				15	mA
$I_L$	$T_j = 25 \text{ }^\circ\text{C}$ Pulse Duration > 20 $\mu\text{s}$	$V_D = 12 \text{ V}$	$I_G = 20 \text{ mA}$	I-III-IV		15		mA
				II		30		
$V_{TM}^*$	$T_j = 25 \text{ }^\circ\text{C}$	$I_{TM} = 5.5 \text{ A}$	$t_p = 10 \text{ ms}$				1.65	V
$I_{DRM}^*$	$V_{DRM}$ Specified						0.01	mA
							0.75	
$dv/dt^*$	$T_j = 110 \text{ }^\circ\text{C}$	Gate Open				10		V/ $\mu\text{s}$
	Linear Slope up to $V_D = 67\% V_{DRM}$							
$(dv/dt)_C^*$	$T_C = 75 \text{ }^\circ\text{C}$	$V_D = V_{DRM}$	$I_T = 5.5 \text{ A}$			1		V/ $\mu\text{s}$
	$(di/dt)_C = 1.8 \text{ A/ms}$							
$t_{gt}$	$T_j = 25 \text{ }^\circ\text{C}$	$V_D = V_{DRM}$	$I_T = 5.5 \text{ A}$	I-II-III-IV		2		$\mu\text{s}$
	$I_G = 20 \text{ mA}$ $di_G/dt = 0.25 \text{ A}/\mu\text{s}$							

\* For either polarity of electrode  $A_2$  voltage with reference to electrode  $A_1$ .

**PACKAGE MECHANICAL DATA**

TO 220 AB Plastic

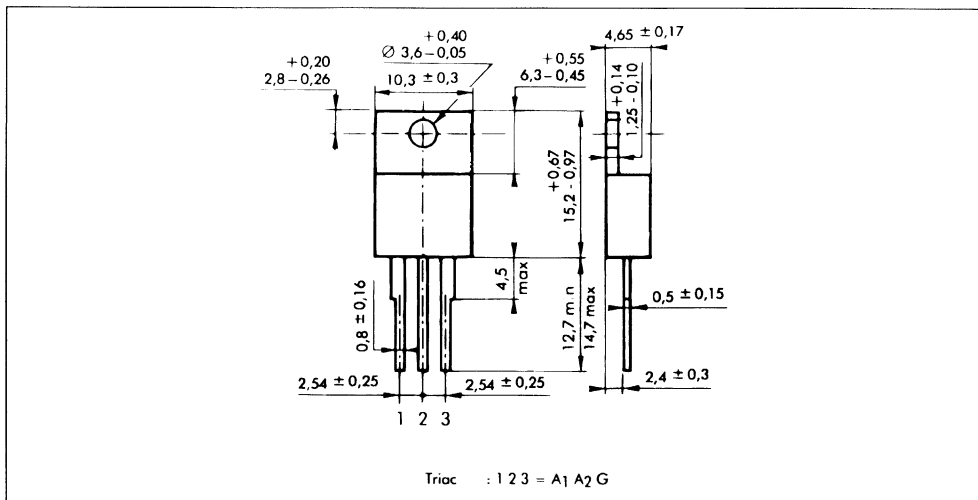

Cooling method : by conduction (method C)

Marking : type number

Weight : 2 g.

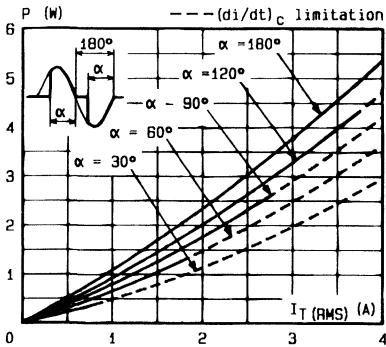

Fig.1 - Maximum mean power dissipation versus RMS on-state current ( $F = 60 \text{ Hz}$ ).

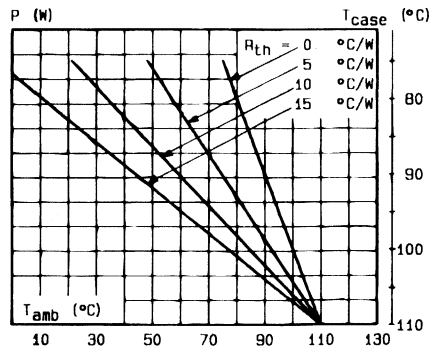

Fig.2 - Correlation between maximum mean power dissipation and maximum allowable temperatures ( $T_{amb}$  and  $T_{case}$ ) for different thermal resistances heatsink + contact.

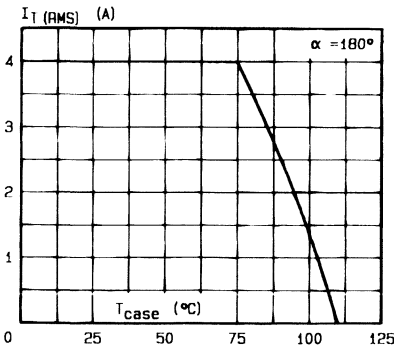

Fig.3 - RMS on-state current versus case temperature.

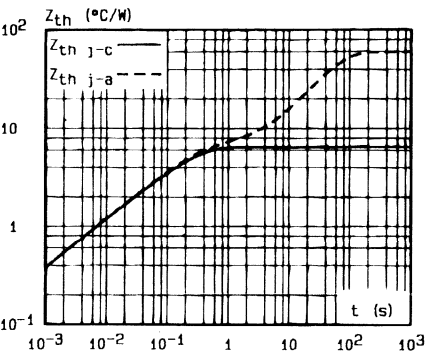

Fig.4 - Thermal transient impedance junction to case and junction to ambient versus pulse duration.

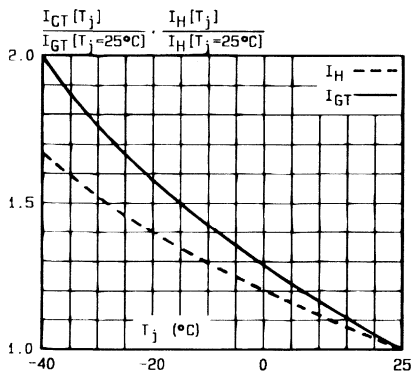

Fig.5 - Relative variation of gate trigger current and holding current versus junction temperature.

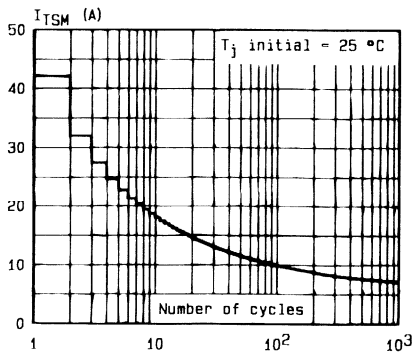

Fig.6 - Non repetitive surge peak on-state current versus number of cycles.

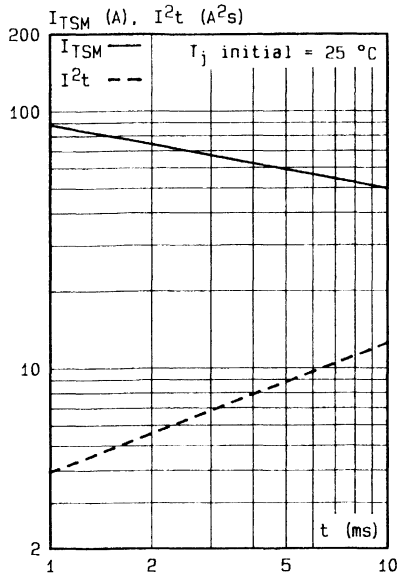

Fig.7 - Non repetitive surge peak on-state current for a sinusoidal pulse with width :  $t \leq 10$  ms, and corresponding value of  $I^2t$ .

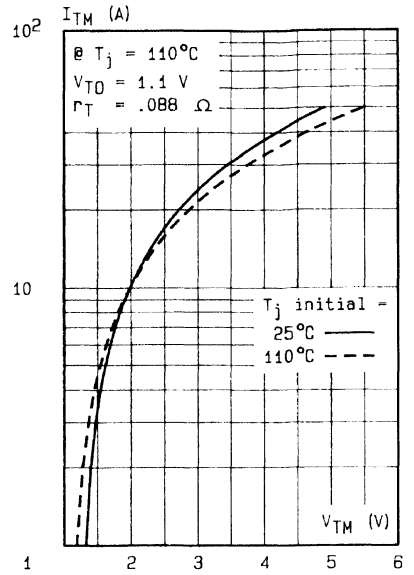
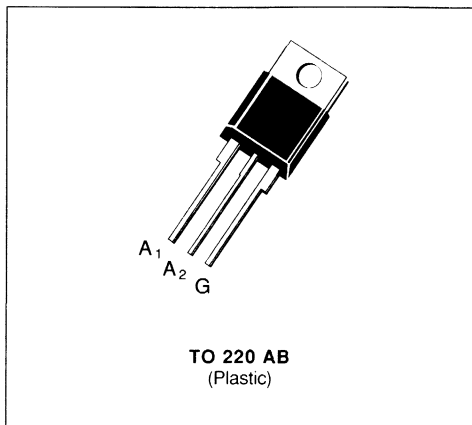

Fig.8 - On-state characteristics (maximum values).



**SENSITIVE GATE TRIACS**

- GLASS PASSIVATED CHIP
- $I_{GT}$  SPECIFIED IN FOUR QUADRANTS
- AVAILABLE IN INSULATED VERSION → BTA SERIES (INSULATING VOLTAGE 2500  $V_{RMS}$ ) OR IN UNINSULATED VERSION → BTB SERIES
- UL RECOGNIZED FOR BTA SERIES (E81734)

**DESCRIPTION**

New range suited for applications such as phase control and static switching.

**ABSOLUTE RATINGS** (limiting values)

Symbol	Parameter	Value	Unit	
$I_{T(RMS)}$	RMS on-state Current (360° conduction angle)	$T_C = 75\text{ °C}$ 4	A	
$I_{TSM}$	Non Repetitive Surge Peak on-state Current ( $T_J$ initial = 25 °C - Half sine wave)	$t = 8.3\text{ ms}$	52	A
		$t = 10\text{ ms}$	50	
$I^2t$	$I^2t$ Value for Fusing	$t = 10\text{ ms}$	12.5	A <sup>2</sup> s
di/dt	Critical Rate of Rise of on-state Current (1)	Repetitive $F = 50\text{ Hz}$	10	A/ $\mu$ s
		Non Repetitive	50	
$T_{stg}$ $T_J$	Storage and Operating Junction Temperature Range	- 40 to 150		°C
		- 40 to 110		°C

Symbol	Parameter	BTA/BTB 04-					Unit
		200S	400S	600S	700S	800S	
$V_{DRM}$	Repetitive Peak off-state Voltage (2)	200	400	600	700	800	V

(1)  $I_G = 100\text{ mA}$      $di_G/dt = 1\text{ A}/\mu\text{s}$

(2)  $T_J = 110\text{ °C}$ .

**THERMAL RESISTANCES**

Symbol	Parameter	Value	Unit
$R_{th(j-a)}$	Junction to Ambient	60	°C/W
$R_{th(j-c)}\text{ DC}$	Junction to Case for DC	8.7	°C/W
$R_{th(j-c)}\text{ AC}$	Junction to Case for 360° Conduction Angle ( $F = 50\text{ Hz}$ )	6.5	°C/W

**GATE CHARACTERISTICS** (maximum values)

$P_{GM} = 40 \text{ W}$  ( $t_p = 10 \mu\text{s}$ )       $I_{GM} = 4 \text{ A}$  ( $t_p = 10 \mu\text{s}$ )  
 $P_{G(AV)} = 1 \text{ W}$        $V_{GM} = 16 \text{ V}$  ( $t_p = 10 \mu\text{s}$ )

**ELECTRICAL CHARACTERISTICS**

Symbol	Test Conditions	Quadrants	Min.	Typ.	Max.	Unit
$I_{GT}$	$T_j = 25 \text{ }^\circ\text{C}$ $V_D = 12 \text{ V}$ $R_L = 33 \text{ } \Omega$ Pulse Duration > 20 $\mu\text{s}$	I-II-III-IV			10	mA
$V_{GT}$	$T_j = 25 \text{ }^\circ\text{C}$ $V_D = 12 \text{ V}$ $R_L = 33 \text{ } \Omega$ Pulse Duration > 20 $\mu\text{s}$	I-II-III-IV			1.5	V
$V_{GD}$	$T_j = 110 \text{ }^\circ\text{C}$ $V_D = V_{DRM}$ $R_L = 3.3 \text{ k}\Omega$	I-II-III-IV	0.2			V
$I_H^*$	$T_j = 25 \text{ }^\circ\text{C}$ $I_T = 100 \text{ mA}$ Gate Open				25	mA
$I_L$	$T_j = 25 \text{ }^\circ\text{C}$ $V_D = 12 \text{ V}$ $I_G = 20 \text{ mA}$ Pulse Duration > 20 $\mu\text{s}$	I-III-IV		25		mA
		II		50		
$V_{TM}^*$	$T_j = 25 \text{ }^\circ\text{C}$ $I_{TM} = 5.5 \text{ A}$ $t_p = 10 \text{ ms}$				1.65	V
$I_{DRM}^*$	$V_{DRM}$ Specified				0.01	mA
					0.75	
$dv/dt^*$	$T_j = 110 \text{ }^\circ\text{C}$ Gate Open Linear Slope up to $V_D = 67\% V_{DRM}$		10			V/ $\mu\text{s}$
$(dv/dt)_c^*$	$T_C = 75 \text{ }^\circ\text{C}$ $V_D = V_{DRM}$ $I_T = 5.5 \text{ A}$ $(di/dt)_c = 1.8 \text{ A/ms}$			5		V/ $\mu\text{s}$
$t_{gt}$	$T_j = 25 \text{ }^\circ\text{C}$ $V_D = V_{DRM}$ $I_T = 5.5 \text{ A}$ $I_G = 40 \text{ mA}$ $di_G/dt = 0.45 \text{ A}/\mu\text{s}$	I-II-III-IV		2		$\mu\text{s}$

\* For either polarity of electrode A<sub>2</sub> voltage with reference to electrode A<sub>1</sub>.

**PACKAGE MECHANICAL DATA**

TO 220 AB Plastic

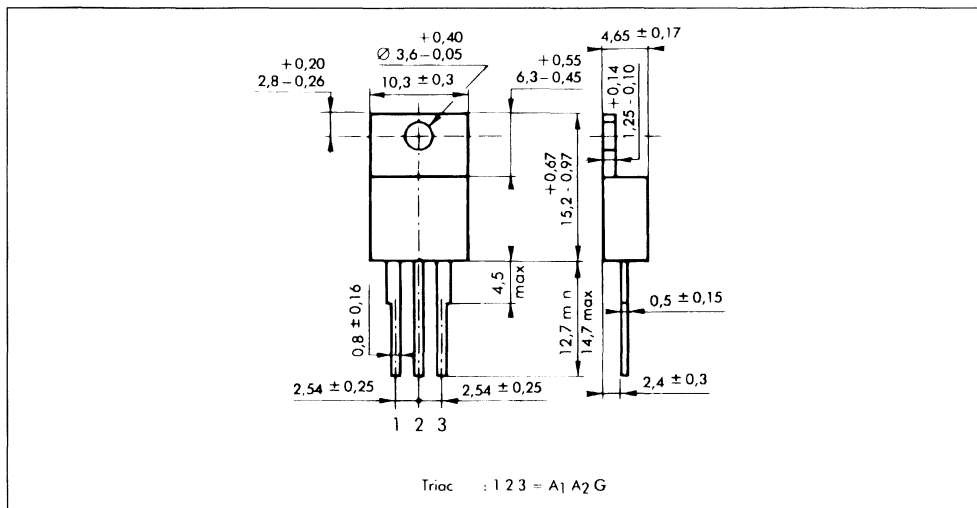

Cooling method : by conduction (method C)  
 Marking : type number  
 Weight : 2 g.

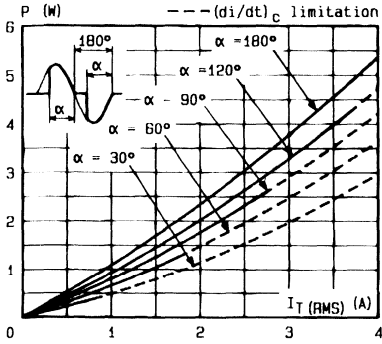

Fig.1 - Maximum mean power dissipation versus RMS on-state current ( $F = 60$  Hz).

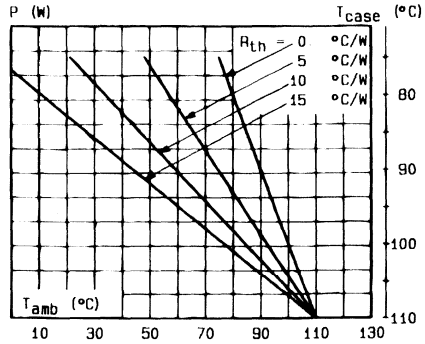

Fig.2 - Correlation between maximum mean power dissipation and maximum allowable temperatures ( $T_{amb}$  and  $T_{case}$ ) for different thermal resistances heatsink + contact.

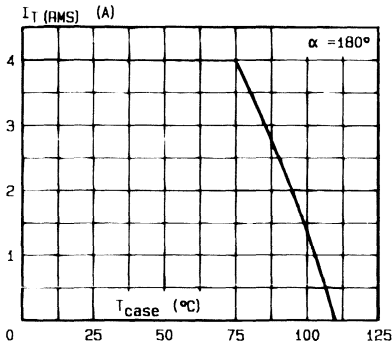

Fig.3 - RMS on-state current versus case temperature.

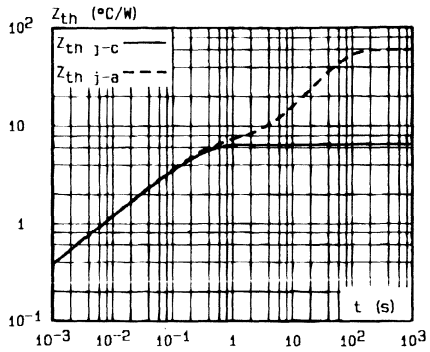

Fig.4 - Thermal transient impedance junction to case and junction to ambient versus pulse duration.

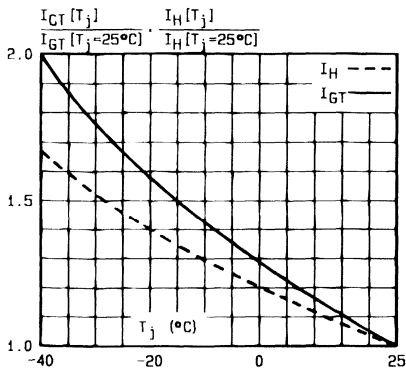

Fig.5 - Relative variation of gate trigger current and holding current versus junction temperature.

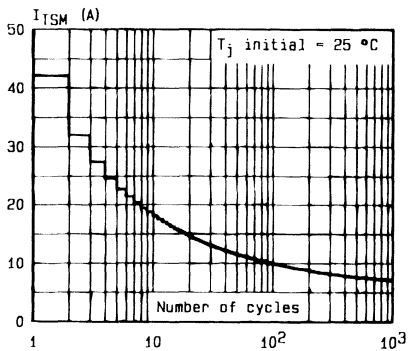

Fig.6 - Non repetitive surge peak on-state current versus number of cycles.

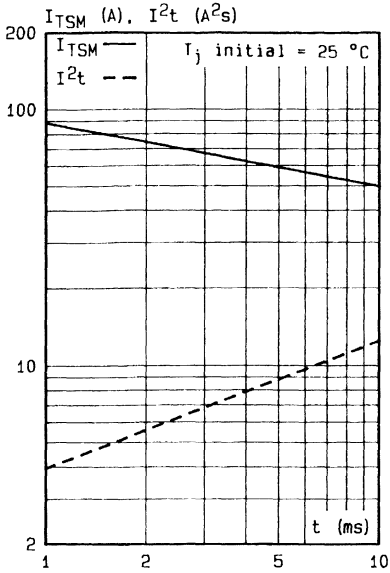

Fig.7 - Non repetitive surge peak on-state current for a sinusoidal pulse with width :  $t \leq 10$  ms, and corresponding value of  $I^2t$ .

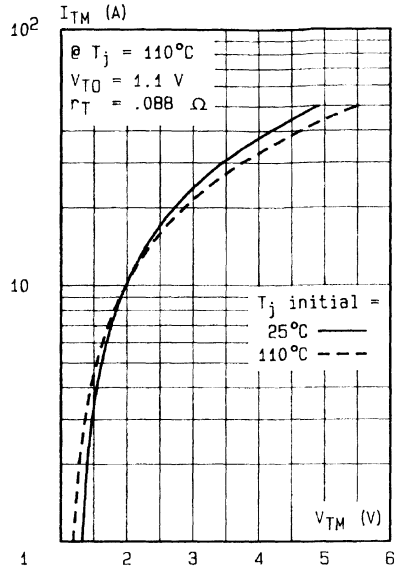
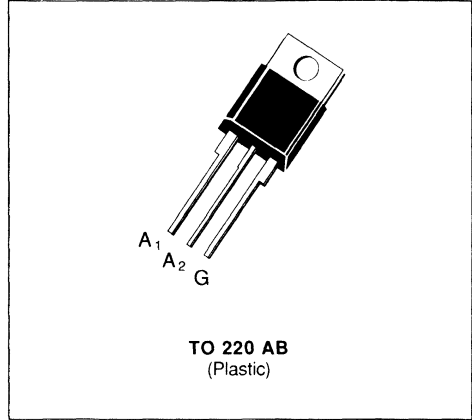

Fig.8 - On-state characteristics (maximum values).

**SENSITIVE GATE TRIACS**

- GLASS PASSIVATED CHIP
- $I_{GT}$  SPECIFIED IN FOUR QUADRANTS
- AVAILABLE IN INSULATED VERSION → BTA SERIES (INSULATING VOLTAGE 2500  $V_{RMS}$ ) OR IN UNINSULATED VERSION → BTB SERIES
- UL RECOGNIZED FOR BTA SERIES (E81734)

**DESCRIPTION**

New range suited for applications such as phase control and static switching.

**ABSOLUTE RATINGS** (limiting values)

Symbol	Parameter	Value	Unit
$I_{T(RMS)}$	RMS on-state Current (360° conduction angle) $T_C = 75\text{ °C}$	4	A
$I_{TSM}$	Non Repetitive Surge Peak on-state Current ( $T_j$ initial = 25 °C - Half sine wave)	$t = 8.3\text{ ms}$	52
		$t = 10\text{ ms}$	50
$I^2t$	$I^2t$ Value for Fusing	$t = 10\text{ ms}$	12.5
di/dt	Critical Rate of Rise of on-state Current (1)	Repetitive $F = 50\text{ Hz}$	10
		Non Repetitive	50
$T_{stg}$ $T_j$	Storage and Operating Junction Temperature Range	- 40 to 150	°C
		- 40 to 110	°C

Symbol	Parameter	BTA/BTB 04-					Unit
		200T	400T	600T	700T	800T	
$V_{DRM}$	Repetitive Peak off-state Voltage (2)	200	400	600	700	800	V

(1)  $I_G = 50\text{ mA}$      $di/dt = 1\text{ A}/\mu\text{s}$

(2)  $T_j = 110\text{ °C}$ .

**THERMAL RESISTANCES**

Symbol	Parameter	Value	Unit
$R_{th(j-a)}$	Junction to Ambient	60	°C/W
$R_{th(j-c)}\text{ DC}$	Junction to Case for DC	8.7	°C/W
$R_{th(j-c)}\text{ AC}$	Junction to Case for 360 ° Conduction Angle ( $F = 50\text{ Hz}$ )	6.5	°C/W

**GATE CHARACTERISTICS** (maximum values)

$P_{GM} = 40 \text{ W}$  ( $t_p = 10 \mu\text{s}$ )

$I_{GM} = 4 \text{ A}$  ( $t_p = 10 \mu\text{s}$ )

$P_{G(AV)} = 1 \text{ W}$

$V_{GM} = 16 \text{ V}$  ( $t_p = 10 \mu\text{s}$ )

**ELECTRICAL CHARACTERISTICS**

Symbol	Test Conditions			Quadrants	Min.	Typ.	Max.	Unit
$I_{GT}$	$T_j = 25 \text{ }^\circ\text{C}$	$V_D = 12 \text{ V}$	$R_L = 33 \text{ } \Omega$	I-II-III-IV			5	mA
	Pulse Duration > 20 $\mu\text{s}$							
$V_{GT}$	$T_j = 25 \text{ }^\circ\text{C}$	$V_D = 12 \text{ V}$	$R_L = 33 \text{ } \Omega$	I-II-III-IV			1.5	V
	Pulse Duration > 20 $\mu\text{s}$							
$V_{GD}$	$T_j = 110 \text{ }^\circ\text{C}$	$V_D = V_{DRM}$	$R_L = 3.3 \text{ k}\Omega$	I-II-III-IV	0.2			V
$I_H^*$	$T_j = 25 \text{ }^\circ\text{C}$	$I_T = 100 \text{ mA}$	Gate Open				15	mA
$I_L$	$T_j = 25 \text{ }^\circ\text{C}$	$V_D = 12 \text{ V}$	$I_G = 10 \text{ mA}$	I-III-IV		15		mA
				II		30		
$V_{TM}^*$	$T_j = 25 \text{ }^\circ\text{C}$	$I_{TM} = 5.5 \text{ A}$	$t_p = 10 \text{ ms}$				1.65	V
$I_{DRM}^*$	$V_{DRM}$ Specified						0.01	mA
							$T_j = 110 \text{ }^\circ\text{C}$	0.75
$dv/dt^*$	$T_j = 110 \text{ }^\circ\text{C}$	Gate Open				10		V/ $\mu\text{s}$
	Linear Slope up to $V_D = 67\% V_{DRM}$							
$(dv/dt)_c^*$	$T_C = 75 \text{ }^\circ\text{C}$	$V_D = V_{DRM}$	$I_T = 5.5 \text{ A}$				1	V/ $\mu\text{s}$
$t_{gt}$	$T_j = 25 \text{ }^\circ\text{C}$	$V_D = V_{DRM}$	$I_T = 5.5 \text{ A}$	I-II-III-IV			2	$\mu\text{s}$

\* For either polarity of electrode  $A_2$  voltage with reference to electrode  $A_1$ .

**PACKAGE MECHANICAL DATA**

TO 220 AB Plastic

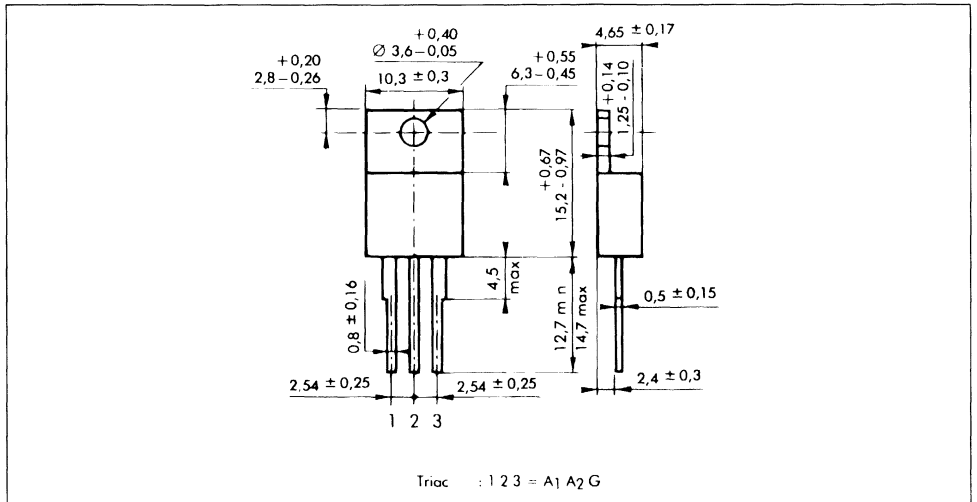

Cooling method : by conduction (method C)

Marking : type number

Weight : 2 g.

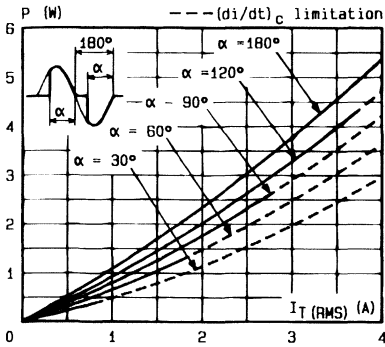

Fig.1 - Maximum mean power dissipation versus RMS on-state current ( $F = 60$  Hz).

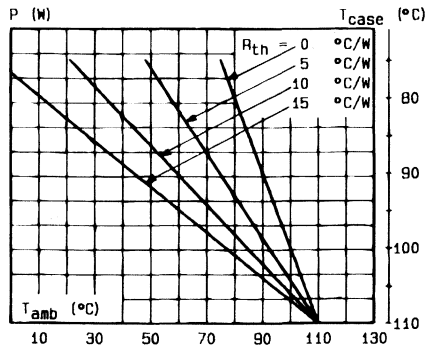

Fig.2 - Correlation between maximum mean power dissipation and maximum allowable temperatures ( $T_{amb}$  and  $T_{case}$ ) for different thermal resistances ( $R_{th}$  heatsink + contact).

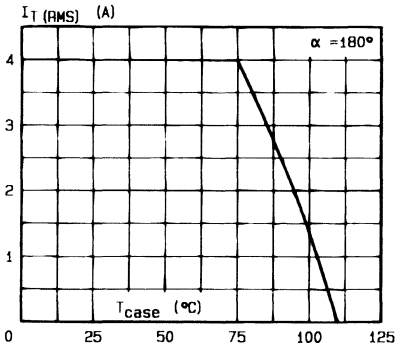

Fig.3 - RMS on-state current versus case temperature.

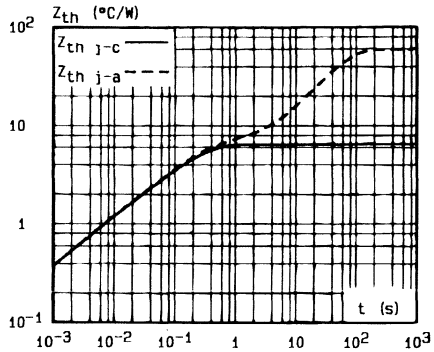

Fig.4 - Thermal transient impedance junction to case and junction to ambient versus pulse duration.

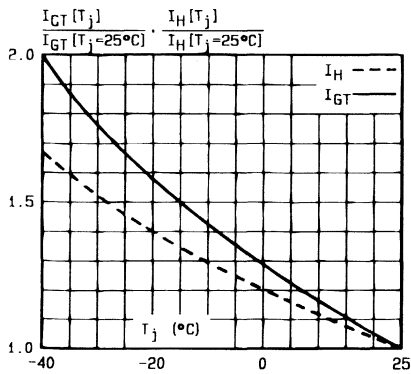

Fig.5 - Relative variation of gate trigger current and holding current versus junction temperature.

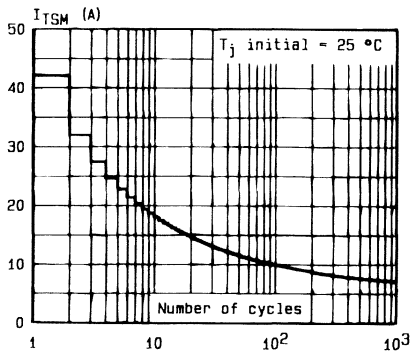

Fig.6 - Non repetitive surge peak on-state current versus number of cycles.

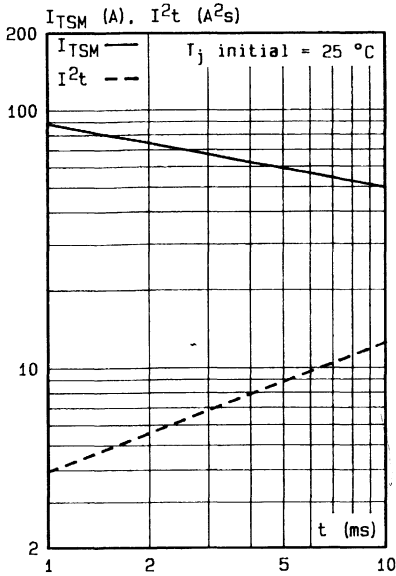

Fig.7 - Non repetitive surge peak on-state current for a sinusoidal pulse with width :  $t \leq 10$  ms, and corresponding value of  $I^2t$ .

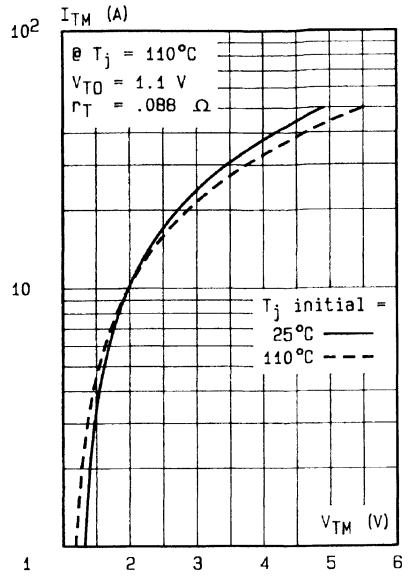
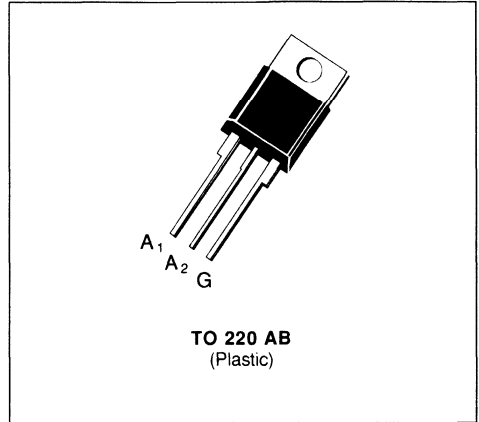

Fig.8 - On-state characteristics (maximum values).



## SENSITIVE GATE TRIACS

- GLASS PASSIVATED CHIP
- $I_{GT}$  SPECIFIED IN FOUR QUADRANTS
- AVAILABLE IN INSULATED VERSION → BTA SERIES (INSULATED VOLTAGE 2500  $V_{RMS}$ ) OR IN UNINSULATED VERSION → BTB SERIES
- UL RECOGNIZED FOR BTA SERIES (E81734)



### DESCRIPTION

New range suited for applications such as phase control and static switching.

### ABSOLUTE RATINGS (limiting values)

Symbol	Parameter	Value	Unit
$I_{T(RMS)}$	RMS on-state Current (360° conduction angle)	$T_C = 75\text{ °C}$ 6	A
$I_{TSM}$	Non Repetitive Surge Peak on-state Current ( $T_j$ initial = 25 °C - Half sine wave)	$t = 8.3\text{ ms}$	63
		$t = 10\text{ ms}$	60
$I^2t$	$I^2t$ Value for Fusing	$t = 10\text{ ms}$ 18	A <sup>2</sup> s
di/dt	Critical Rate of Rise of on-state Current (1)	Repetitive $F = 50\text{ Hz}$	10
		Non Repetitive	50
$T_{stg}$ $T_j$	Storage and Operating Junction Temperature Range	- 40 to 150	°C
		- 40 to 110	°C

Symbol	Parameter	BTA/BTB 06-					Unit
		200A	400A	600A	700A	800A	
$V_{DRM}$	Repetitive Peak off-state Voltage (2)	200	400	600	700	800	V

(1)  $I_G = 250\text{ mA}$      $di_G/dt = 1\text{ A}/\mu\text{s}$

(2)  $T_j = 110\text{ °C}$ .

### THERMAL RESISTANCES

Symbol	Parameter	Value	Unit
$R_{th(j-a)}$	Junction to Ambient	60	°C/W
$R_{th(j-c)}\text{ DC}$	Junction to Case for DC	5.8	°C/W
$R_{th(j-c)}\text{ AC}$	Junction to Case for 360 ° Conduction Angle ( $F = 50\text{ Hz}$ )	4.3	°C/W

**GATE CHARACTERISTICS** (maximum values)

$P_{GM} = 40 \text{ W}$  ( $t_p = 10 \mu\text{s}$ )       $I_{GM} = 4 \text{ A}$  ( $t_p = 10 \mu\text{s}$ )  
 $P_{G(AV)} = 1 \text{ W}$        $V_{GM} = 16 \text{ V}$  ( $t_p = 10 \mu\text{s}$ )

**ELECTRICAL CHARACTERISTICS**

Symbol	Test Conditions			Quadrants	Min.	Typ.	Max.	Unit
$I_{GT}$	$T_j = 25 \text{ }^\circ\text{C}$ Pulse Duration > 20 $\mu\text{s}$	$V_D = 12 \text{ V}$	$R_L = 33 \text{ } \Omega$	I-II-III			10	mA
				IV			25	
$V_{GT}$	$T_j = 25 \text{ }^\circ\text{C}$ Pulse Duration > 20 $\mu\text{s}$	$V_D = 12 \text{ V}$	$R_L = 33 \text{ } \Omega$	I-II-III-IV			1.5	V
$V_{GD}$	$T_j = 110 \text{ }^\circ\text{C}$	$V_D = V_{DRM}$	$R_L = 3.3 \text{ k}\Omega$	I-II-III-IV	0.2			V
$I_{H^*}$	$T_j = 25 \text{ }^\circ\text{C}$	$I_T = 100 \text{ mA}$	Gate Open				25	mA
$I_L$	$T_j = 25 \text{ }^\circ\text{C}$ Pulse Duration > 20 $\mu\text{s}$	$V_D = 12 \text{ V}$	$I_G = 50 \text{ mA}$	I-III-IV				mA
				II			50	
$V_{TM}^*$	$T_j = 25 \text{ }^\circ\text{C}$	$I_{TM} = 8.5 \text{ A}$	$t_p = 10 \text{ ms}$				1.65	V
$I_{DRM}^*$	$V_{DRM}$ Specified						0.01	mA
							0.75	
$dv/dt^*$	$T_j = 110 \text{ }^\circ\text{C}$	Gate Open	Linear Slope up to $V_D = 67\% V_{DRM}$		10			V/ $\mu\text{s}$
$(dv/dt)_c^*$	$T_C = 75 \text{ }^\circ\text{C}$ $(di/dt)_c = 2.7 \text{ A/ms}$	$V_D = V_{DRM}$	$I_T = 8.5 \text{ A}$			5		V/ $\mu\text{s}$
$t_{gt}$	$T_j = 25 \text{ }^\circ\text{C}$	$V_D = V_{DRM}$	$I_T = 8.5 \text{ A}$	I-II-III-IV		2		$\mu\text{s}$

\* For either polarity of electrode  $A_2$  voltage with reference to electrode  $A_1$ .

**PACKAGE MECHANICAL DATA**

TO 220 AB Plastic

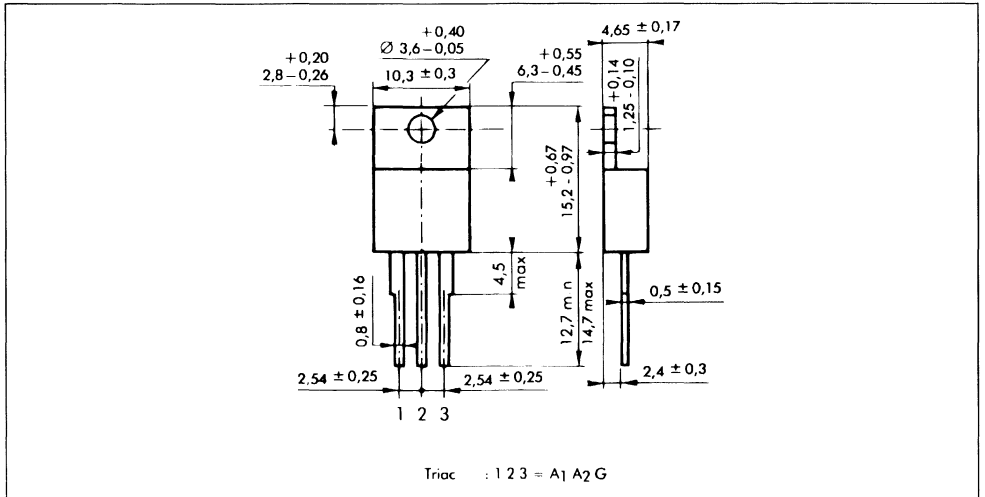

Cooling method : by conduction (method C)

Marking : type number

Weight : 2 g.

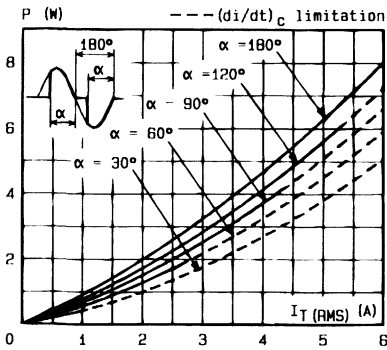

Fig.1 - Maximum mean power dissipation versus RMS on-state current ( $F = 60$  Hz).

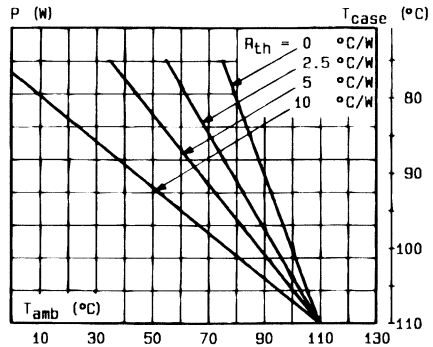

Fig.2 - Correlation between maximum mean power dissipation and maximum allowable temperatures ( $T_{amb}$  and  $T_{case}$ ) for different thermal resistances heatsink + contact.

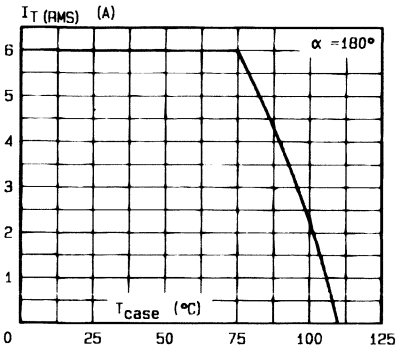

Fig.3 - RMS on-state current versus case temperature.

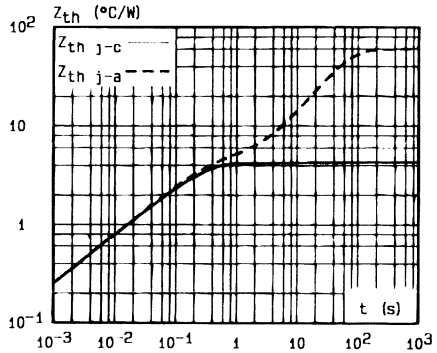

Fig.4 - Thermal transient impedance junction to case and junction to ambient versus pulse duration.

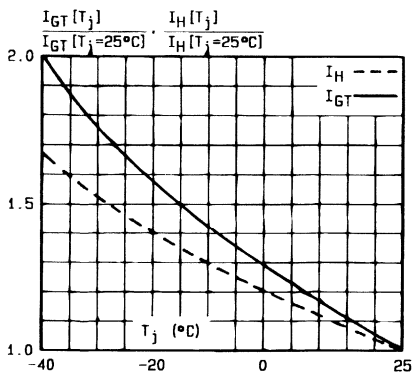

Fig.5 - Relative variation of gate trigger current and holding current versus junction temperature.

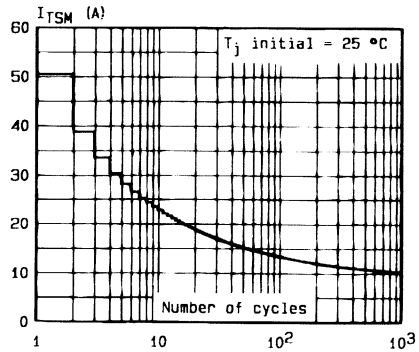

Fig.6 - Non repetitive surge peak on-state current versus number of cycles.

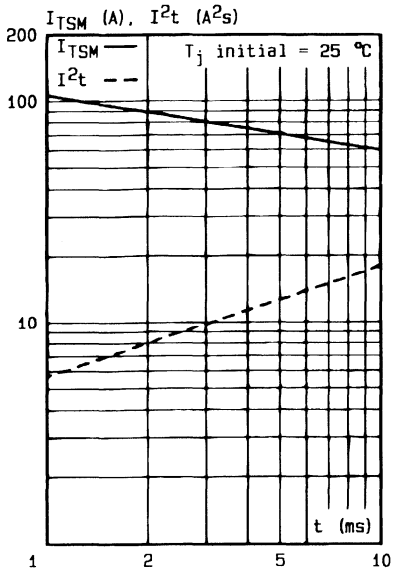

Fig.7 - Non repetitive surge peak on-state current for a sinusoidal pulse with width :  $t \leq 10$  ms, and corresponding value of  $I^2t$ .

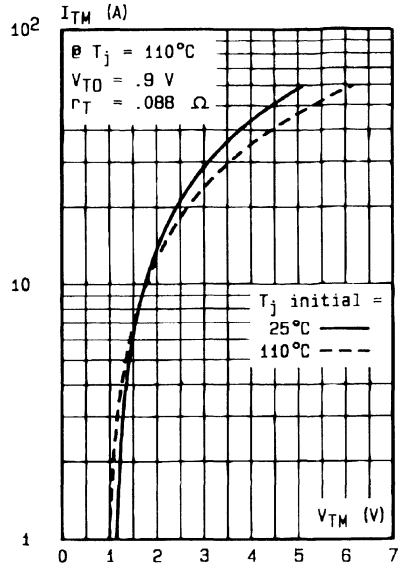
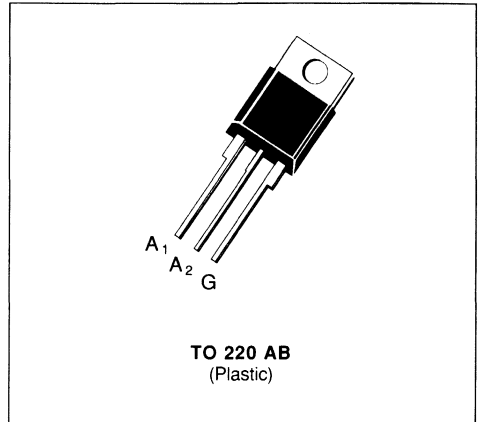

Fig.8 - On-state characteristics (maximum values).

## TRIACS

- GLASS PASSIVATED CHIP
- EXCELLENT  $(dv/dt)_c > 10 \text{ V}/\mu\text{s}$
- $I_{GT}$  SPECIFIED IN FOUR QUADRANTS
- AVAILABLE IN INSULATED VERSION → BTA SERIES (INSULATING VOLTAGE 2500  $V_{RMS}$ ) OR IN UNINSULATED VERSION → BTB SERIES
- UL RECOGNIZED FOR BTA SERIES (E81734)



### DESCRIPTION

New range suited for applications such as phase control and static switching.

### ABSOLUTE RATINGS (limiting values)

Symbol	Parameter	Value	Unit
$I_{T(RMS)}$	RMS on-state Current (360° conduction angle)	$T_C = 75 \text{ }^\circ\text{C}$ 6	A
$I_{TSM}$	Non Repetitive Surge Peak on-state Current ( $T_J$ initial = 25 °C - Half sine wave)	$t = 8.3 \text{ ms}$	63
		$t = 10 \text{ ms}$	60
$I^2t$	$I^2t$ Value for Fusing	$t = 10 \text{ ms}$ 18	$\text{A}^2\text{s}$
$di/dt$	Critical Rate of Rise of on-state Current (1)	Repetitive $F = 50 \text{ Hz}$	10
		Non Repetitive	50
$T_{stg}$ $T_J$	Storage and Operating Junction Temperature Range	- 40 to 150	$^\circ\text{C}$
		- 40 to 110	$^\circ\text{C}$

Symbol	Parameter	BTA/BTB 06-					Unit
		200B	400B	600B	700B	800B	
$V_{DRM}$	Repetitive Peak off-state Voltage (2)	200	400	600	700	800	V

(1)  $I_G = 1 \text{ A}$   $di_G/dt = 1 \text{ A}/\mu\text{s}$

(2)  $T_J = 110 \text{ }^\circ\text{C}$ .

### THERMAL RESISTANCES

Symbol	Parameter	Value	Unit
$R_{th(j-a)}$	Junction to Ambient	60	$^\circ\text{C}/\text{W}$
$R_{th(j-c)} \text{ DC}$	Junction to Case for DC	6.1	$^\circ\text{C}/\text{W}$
$R_{th(j-c)} \text{ AC}$	Junction to Case for 360° Conduction Angle ( $F = 50 \text{ Hz}$ )	4.6	$^\circ\text{C}/\text{W}$

**GATE CHARACTERISTICS** (maximum values)

$P_{GM} = 40 \text{ W}$  ( $t_p = 10 \mu\text{s}$ )       $I_{GM} = 4 \text{ A}$  ( $t_p = 10 \mu\text{s}$ )  
 $P_{G(AV)} = 1 \text{ W}$        $V_{GM} = 16 \text{ V}$  ( $t_p = 10 \mu\text{s}$ )

**ELECTRICAL CHARACTERISTICS**

Symbol	Test Conditions	Quadrants	Min.	Typ.	Max.	Unit
$I_{GT}$	$T_j = 25 \text{ }^\circ\text{C}$ $V_D = 12 \text{ V}$ $R_L = 33 \text{ } \Omega$ Pulse Duration > 20 $\mu\text{s}$	I-II-III			50	mA
		IV			100	
$V_{GT}$	$T_j = 25 \text{ }^\circ\text{C}$ $V_D = 12 \text{ V}$ $R_L = 33 \text{ } \Omega$ Pulse Duration > 20 $\mu\text{s}$	I-II-III-IV			1.5	V
$V_{GD}$	$T_j = 110 \text{ }^\circ\text{C}$ $V_D = V_{DRM}$ $R_L = 3.3 \text{ k}\Omega$	I-II-III-IV	0.2			V
$I_{H^*}$	$T_j = 25 \text{ }^\circ\text{C}$ $I_T = 100 \text{ mA}$ Gate Open				50	mA
$I_L$	$T_j = 25 \text{ }^\circ\text{C}$ $V_D = 12 \text{ V}$ $I_G = 200 \text{ mA}$ Pulse Duration > 20 $\mu\text{s}$	I-III-IV		50		
		II		100		
$V_{TM}^*$	$T_j = 25 \text{ }^\circ\text{C}$ $I_{TM} = 8.5 \text{ A}$ $t_p = 10 \text{ ms}$				1.65	V
$I_{DRM}^*$	$V_{DRM}$ Specified	$T_j = 25 \text{ }^\circ\text{C}$			0.01	mA
		$T_j = 110 \text{ }^\circ\text{C}$			0.5	
$dv/dt^*$	$T_j = 110 \text{ }^\circ\text{C}$ Gate Open Linear Slope up to $V_D = 67 \% V_{DRM}$		250	500		V/ $\mu\text{s}$
$(dv/dt)_c^*$	$T_c = 75 \text{ }^\circ\text{C}$ $V_D = V_{DRM}$ $I_T = 8.5 \text{ A}$ $(di/dt)_c = 2.7 \text{ A/ms}$		10			V/ $\mu\text{s}$
$t_{gt}$	$T_j = 25 \text{ }^\circ\text{C}$ $V_D = V_{DRM}$ $I_T = 8.5 \text{ A}$ $I_G = 80 \text{ mA}$ $di_G/dt = 1 \text{ A}/\mu\text{s}$	I-II-III-IV		2		$\mu\text{s}$

\* For either polarity of electrode A<sub>2</sub> voltage with reference to electrode A<sub>1</sub>.

**PACKAGE MECHANICAL DATA**

TO 220 AB Plastic

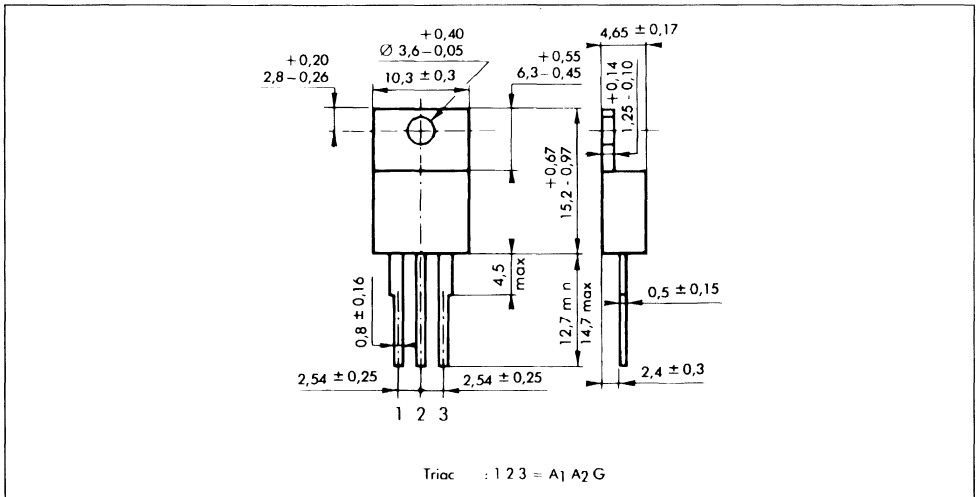

Cooling method : by conduction (method C)

Marking : type number

Weight : 2 g.

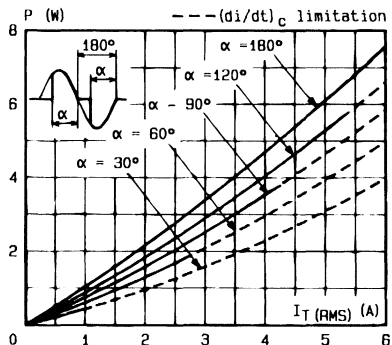

Fig. 1 - Maximum mean power dissipation versus RMS on-state current ( $F = 60 \text{ Hz}$ ).

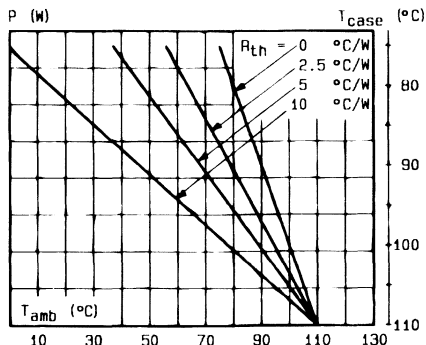

Fig. 2 - Correlation between maximum mean power dissipation and maximum allowable temperatures ( $T_{amb}$  and  $T_{case}$ ) for different thermal resistances heatsink + contact.

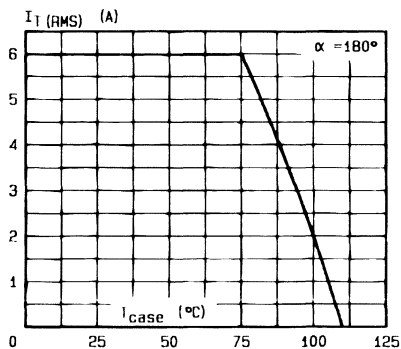

Fig. 3 - RMS on-state current versus case temperature.

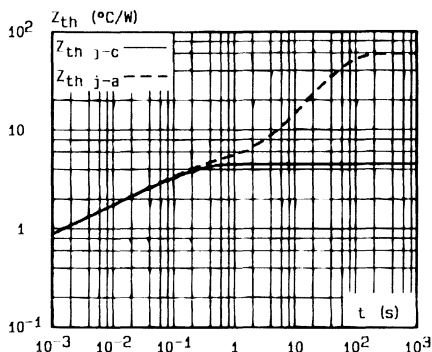

Fig. 4 - Thermal transient impedance junction to case and junction to ambient versus pulse duration.

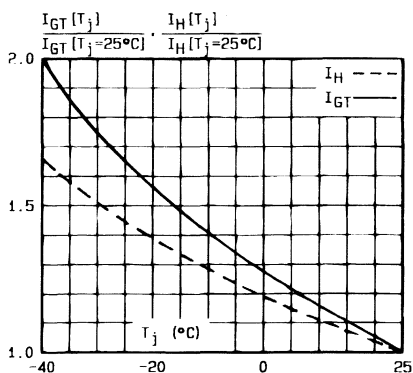

Fig. 5 - Relative variation of gate trigger current and holding current versus junction temperature.

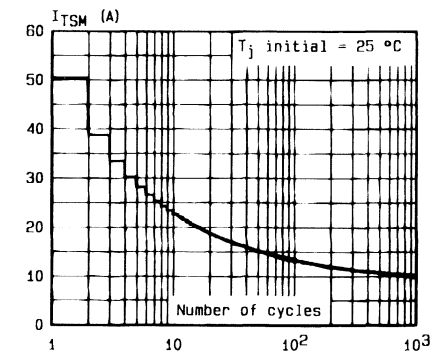

Fig. 6 - Non repetitive surge peak on-state current versus number of cycles.

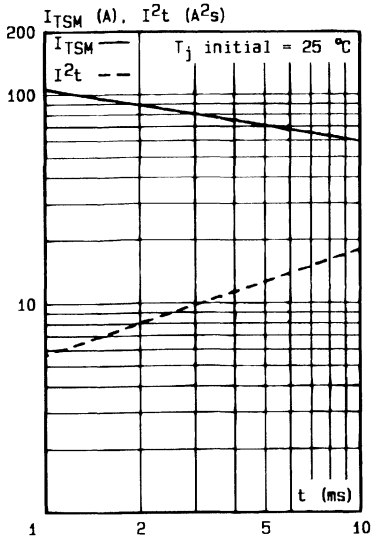

Fig.7 - Non repetitive surge peak on-state current for a sinusoidal pulse with width :  $t \leq 10$  ms, and corresponding value of  $I^2t$ .

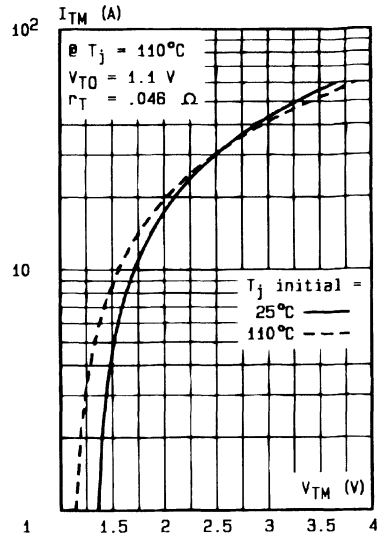
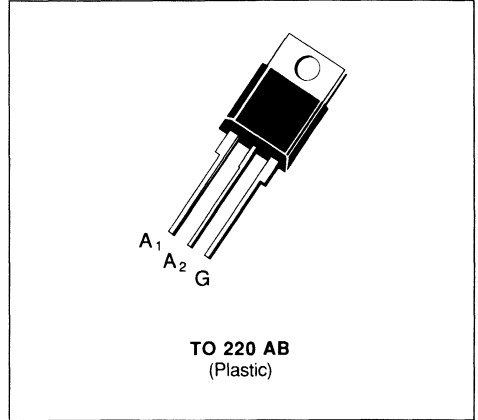

Fig.8 - Un-state characteristics (maximum values).



**TRIACS**

- GLASS PASSIVATED CHIP
- EXCELLENT  $(dv/dt)_c > 5 \text{ V}/\mu\text{s}$
- $I_{GT}$  SPECIFIED IN FOUR QUADRANTS
- AVAILABLE IN INSULATED VERSION → BTA SERIES (INSULATING VOLTAGE 2500  $V_{RMS}$ ) OR IN UNINSULATED VERSION → BTB SERIES
- UL RECOGNIZED FOR BTA SERIES (E81734)

**DESCRIPTION**

New range suited for applications such as phase control and static switching.

**ABSOLUTE RATINGS** (limiting values)

Symbol	Parameter	Value	Unit
$I_{T(RMS)}$	RMS on-state Current (360° conduction angle) $T_C = 75^\circ\text{C}$	6	A
$I_{TSM}$	Non Repetitive Surge Peak on-state Current ( $T_J$ initial = 25 °C - Half sine wave)	$t = 8.3 \text{ ms}$	63
		$t = 10 \text{ ms}$	60
$I^2t$	$I^2t$ Value for Fusing	$t = 10 \text{ ms}$	18
$di/dt$	Critical Rate of Rise of on-state Current (1)	Repetitive $F = 50 \text{ Hz}$	10
		Non Repetitive	50
$T_{stg}$ $T_J$	Storage and Operating Junction Temperature Range	- 40 to 150 - 40 to 110	°C °C

Symbol	Parameter	BTA/BTB 06-					Unit
		200C	400C	600C	700C	800C	
$V_{DRM}$	Repetitive Peak off-state Voltage (2)	200	400	600	700	800	V

(1)  $I_G = 500 \text{ mA}$   $di_G/dt = 1 \text{ A}/\mu\text{s}$

(2)  $T_J = 110^\circ\text{C}$ .

**THERMAL RESISTANCES**

Symbol	Parameter	Value	Unit
$R_{th(j-a)}$	Junction to Ambient	60	°C/W
$R_{th(j-c)} \text{ DC}$	Junction to Case for DC	6.1	°C/W
$R_{th(j-c)} \text{ AC}$	Junction to Case for 360° Conduction Angle ( $F = 50 \text{ Hz}$ )	4.6	°C/W

**GATE CHARACTERISTICS** (maximum values)

$P_{GM} = 40 \text{ W}$  ( $t_p = 10 \mu\text{s}$ )       $I_{GM} = 4 \text{ A}$  ( $t_p = 10 \mu\text{s}$ )  
 $P_{G(AV)} = 1 \text{ W}$        $V_{GM} = 16 \text{ V}$  ( $t_p = 10 \mu\text{s}$ )

**ELECTRICAL CHARACTERISTICS**

Symbol	Test Conditions	Quadrants	Min.	Typ.	Max.	Unit
$I_{GT}$	$T_j = 25 \text{ }^\circ\text{C}$ $V_D = 12 \text{ V}$ $R_L = 33 \text{ } \Omega$ Pulse Duration > 20 $\mu\text{s}$	I-II-III			25	mA
		IV			50	
$V_{GT}$	$T_j = 25 \text{ }^\circ\text{C}$ $V_D = 12 \text{ V}$ $R_L = 33 \text{ } \Omega$ Pulse Duration > 20 $\mu\text{s}$	I-II-III-IV			1.5	V
$V_{GD}$	$T_j = 110 \text{ }^\circ\text{C}$ $V_D = V_{DRM}$ $R_L = 3.3 \text{ k}\Omega$	I-II-III-IV	0.2			V
$I_H^*$	$T_j = 25 \text{ }^\circ\text{C}$ $I_T = 100 \text{ mA}$ Gate Open				25	mA
$I_L$	$T_j = 25 \text{ }^\circ\text{C}$ $V_D = 12 \text{ V}$ $I_G = 100 \text{ mA}$ Pulse Duration > 20 $\mu\text{s}$	I-III-IV		50		mA
		II		100		
$V_{TM}^*$	$T_j = 25 \text{ }^\circ\text{C}$ $I_{TM} = 8.5 \text{ A}$ $t_p = 10 \text{ ms}$				1.65	V
$I_{DRM}^*$	$V_{DRM}$ Specified				0.01	mA
					$T_j = 110 \text{ }^\circ\text{C}$	
$dv/dt^*$	$T_j = 110 \text{ }^\circ\text{C}$ Gate Open Linear Slope up to $V_D = 67\% V_{DRM}$		100	200		V/ $\mu\text{s}$
$(dv/dt)_c^*$	$T_C = 75 \text{ }^\circ\text{C}$ $V_D = V_{DRM}$ $I_T = 8.5 \text{ A}$ $(di/dt)_c = 2.7 \text{ A/ms}$		5			V/ $\mu\text{s}$
$t_{gt}$	$T_j = 25 \text{ }^\circ\text{C}$ $V_D = V_{DRM}$ $I_T = 8.5 \text{ A}$ $I_G = 80 \text{ mA}$ $di_G/dt = 1 \text{ A}/\mu\text{s}$	I-II-III-IV		2		$\mu\text{s}$

\* For either polarity of electrode  $A_2$  voltage with reference to electrode  $A_1$ .

**PACKAGE MECHANICAL DATA**

TO 220 AB Plastic

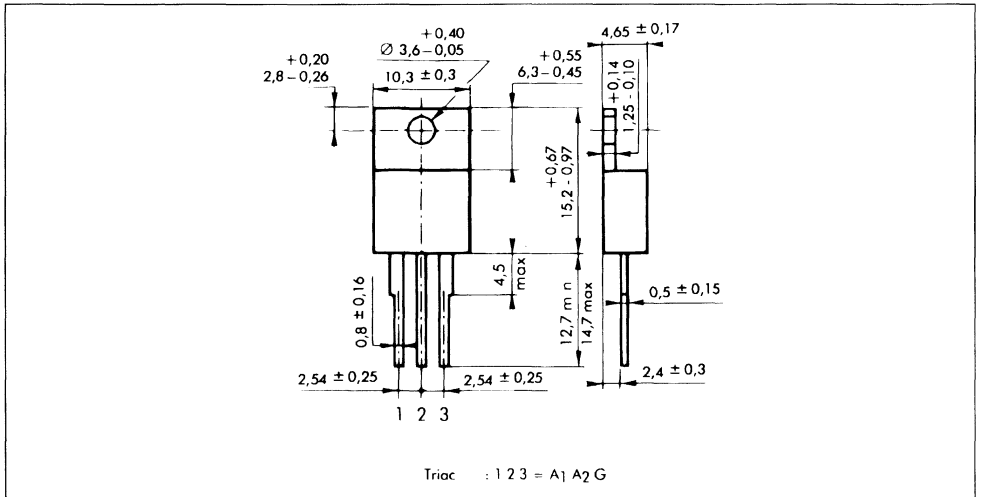

Cooling method : by conduction (method C)  
 Marking : type number  
 Weight : 2 g.

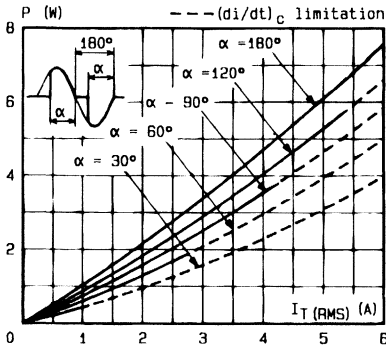

Fig.1 - Maximum mean power dissipation versus RMS on-state current ( $F = 60 \text{ Hz}$ ).

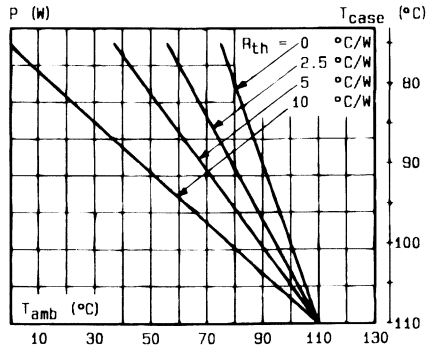

Fig.2 - Correlation between maximum mean power dissipation and maximum allowable temperatures ( $T_{amb}$  and  $T_{case}$ ) for different thermal resistances heatsink + contact.

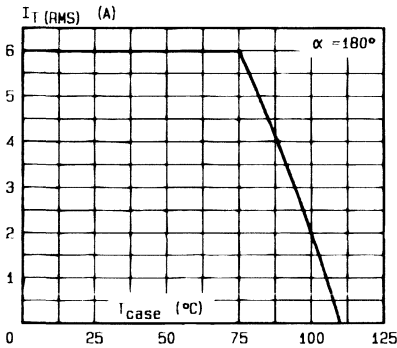

Fig.3 - RMS on-state current versus case temperature.

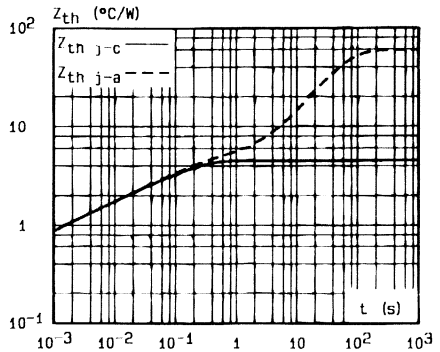

Fig.4 - Thermal transient impedance junction to case and junction to ambient versus pulse duration.

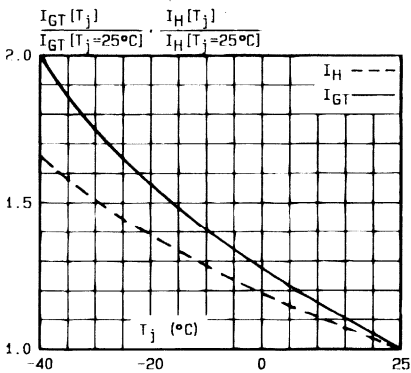

Fig.5 - Relative variation of gate trigger current and holding current versus junction temperature.

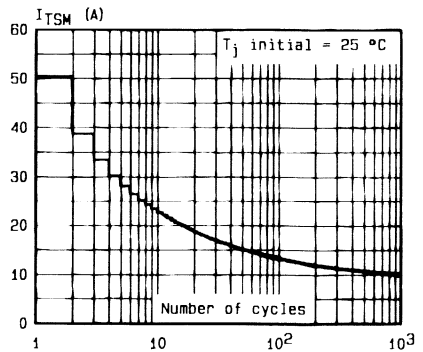

Fig.6 - Non repetitive surge peak on-state current versus number of cycles.

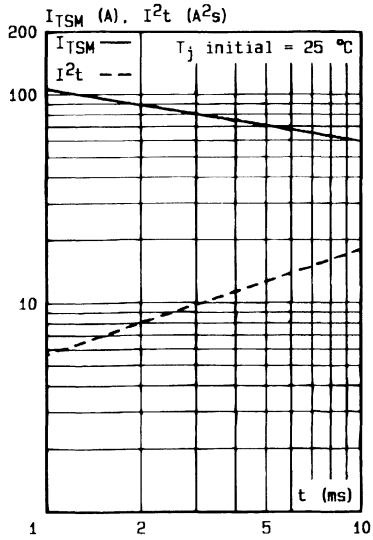

Fig.7 - Non repetitive surge peak on-state current for a sinusoidal pulse with width :  $t \leq 10$  ms, and corresponding value of  $I^2t$ .

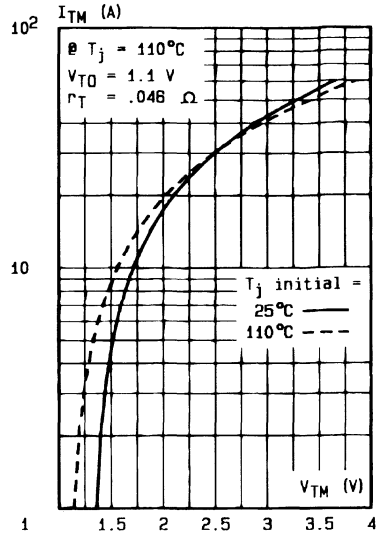
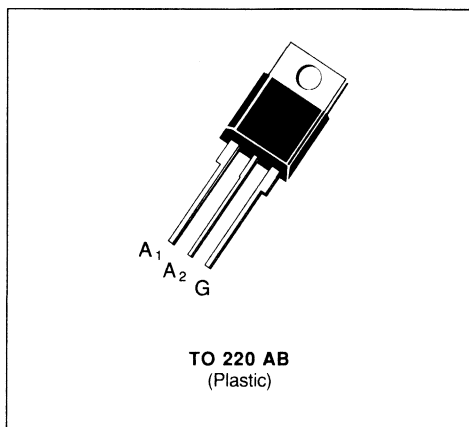

Fig.8 - On-state characteristics (maximum values).

**SENSITIVE GATE TRIACS**

- GLASS PASSIVATED CHIP
- $I_{GT}$  SPECIFIED IN FOUR QUADRANTS
- AVAILABLE IN INSULATED VERSION → BTA SERIES (INSULATING VOLTAGE 2500  $V_{RMS}$ ) OR IN UNINSULATED VERSION → BTB SERIES
- UL RECOGNIZED FOR BTA SERIES (E81734)

**DESCRIPTION**

New range suited for applications such as phase control and static switching.

**ABSOLUTE RATINGS** (limiting values)

Symbol	Parameter	Value	Unit
$I_{T(RMS)}$	RMS on-state Current (360° conduction angle) $T_C = 75\text{ }^\circ\text{C}$	6	A
$I_{TSM}$	Non Repetitive Surge Peak on-state Current ( $T_j$ initial = 25 °C - Half sine wave)	$t = 8.3\text{ ms}$	63
		$t = 10\text{ ms}$	60
$I^2t$	$I^2t$ Value for Fusing $t = 10\text{ ms}$	18	$A^2s$
di/dt	Critical Rate of Rise of on-state Current (1)	Repetitive $F = 50\text{ Hz}$	10
		Non Repetitive	50
$T_{stg}$ $T_j$	Storage and Operating Junction Temperature Range	- 40 to 150	°C
		- 40 to 110	°C

Symbol	Parameter	BTA/BTB 06-					Unit
		200D	400D	600D	700D	800D	
$V_{DRM}$	Repetitive Peak off-state Voltage (2)	200	400	600	700	800	V

(1)  $I_G = 100\text{ mA}$      $di_G/dt = 1\text{ A}/\mu\text{s}$

(2)  $T_j = 110\text{ }^\circ\text{C}$ .

**THERMAL RESISTANCES**

Symbol	Parameter	Value	Unit
$R_{th(j-a)}$	Junction to Ambient	60	°C/W
$R_{th(j-c)}\text{ DC}$	Junction to Case for DC	5.8	°C/W
$R_{th(j-c)}\text{ AC}$	Junction to Case for 360 ° Conduction Angle ( $F = 50\text{ Hz}$ )	4.3	°C/W

**GATE CHARACTERISTICS** (maximum values)

$P_{GM} = 40 \text{ W}$  ( $t_p = 10 \mu\text{s}$ )       $I_{GM} = 4 \text{ A}$  ( $t_p = 10 \mu\text{s}$ )  
 $P_{G(AV)} = 1 \text{ W}$        $V_{GM} = 16 \text{ V}$  ( $t_p = 10 \mu\text{s}$ )

**ELECTRICAL CHARACTERISTICS**

Symbol	Test Conditions			Quadrants	Min.	Typ.	Max.	Unit
$I_{GT}$	$T_j = 25 \text{ }^\circ\text{C}$ Pulse Duration > 20 $\mu\text{s}$	$V_D = 12 \text{ V}$	$R_L = 33 \text{ } \Omega$	I-II-III			5	mA
				IV			10	
$V_{GT}$	$T_j = 25 \text{ }^\circ\text{C}$ Pulse Duration > 20 $\mu\text{s}$	$V_D = 12 \text{ V}$	$R_L = 33 \text{ } \Omega$	I-II-III-IV			1.5	V
$V_{GD}$	$T_j = 110 \text{ }^\circ\text{C}$	$V_D = V_{DRM}$	$R_L = 3.3 \text{ k}\Omega$	I-II-III-IV	0.2			V
$I_{H^*}$	$T_j = 25 \text{ }^\circ\text{C}$	$I_T = 100 \text{ mA}$	Gate Open				15	mA
$I_L$	$T_j = 25 \text{ }^\circ\text{C}$ Pulse Duration > 20 $\mu\text{s}$	$V_D = 12 \text{ V}$	$I_G = 20 \text{ mA}$	I-III-IV		15		mA
				II		30		
$V_{TM}^*$	$T_j = 25 \text{ }^\circ\text{C}$	$I_{TM} = 8.5 \text{ A}$	$t_p = 10 \text{ ms}$				1.65	V
$I_{DRM}^*$	$V_{DRM}$ Specified						0.01	mA
		$T_j = 25 \text{ }^\circ\text{C}$	$T_j = 110 \text{ }^\circ\text{C}$				0.75	
$dv/dt^*$	$T_j = 110 \text{ }^\circ\text{C}$	Gate Open Linear Slope up to $V_D = 67\% V_{DRM}$				10		V/ $\mu\text{s}$
$(dv/dt)_c^*$	$T_C = 75 \text{ }^\circ\text{C}$ $(di/dt)_c = 2.7 \text{ A/ms}$	$V_D = V_{DRM}$	$I_T = 8.5 \text{ A}$			1		V/ $\mu\text{s}$
$t_{gt}$	$T_j = 25 \text{ }^\circ\text{C}$	$V_D = V_{DRM}$ $I_G = 20 \text{ mA}$	$I_T = 8.5 \text{ A}$ $di_G/dt = 0.25 \text{ A}/\mu\text{s}$	I-II-III-IV		2		$\mu\text{s}$

\* For either polarity of electrode  $A_2$  voltage with reference to electrode  $A_1$ .

**PACKAGE MECHANICAL DATA**

TO 220 AB Plastic

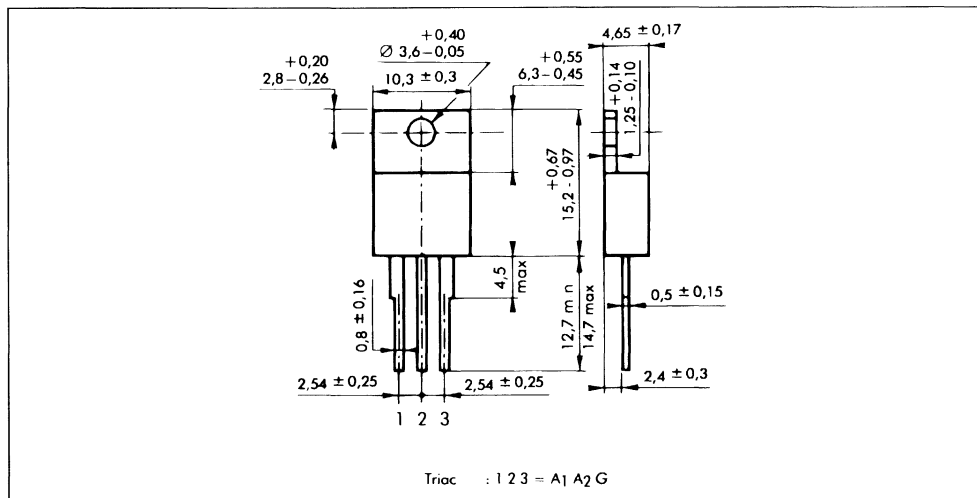

Cooling method : by conduction (method C)  
 Marking : type number  
 Weight : 2 g.

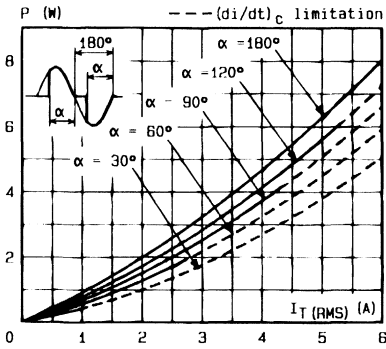

Fig.1 - Maximum mean power dissipation versus RMS on-state current ( $F = 60$  Hz).

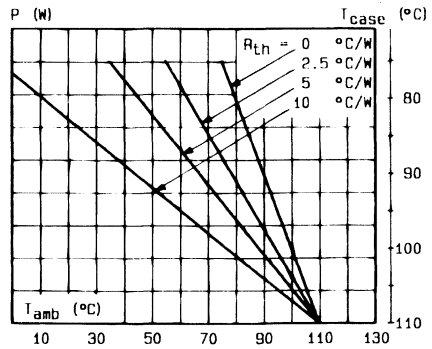

Fig.2 - Correlation between maximum mean power dissipation and maximum allowable temperatures ( $T_{amb}$  and  $T_{case}$ ) for different thermal resistances heatsink + contact.

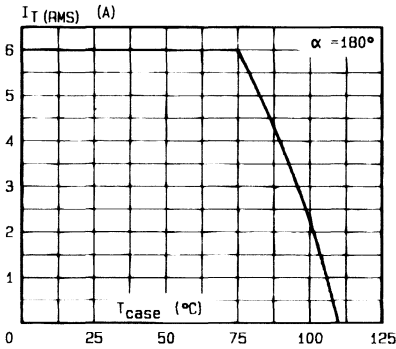

Fig.3 - RMS on-state current versus case temperature.

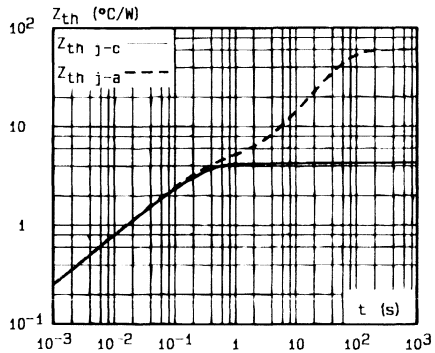

Fig.4 - Thermal transient impedance junction to case and junction to ambient versus pulse duration.

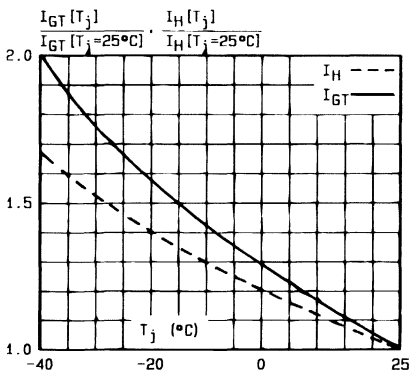

Fig.5 - Relative variation of gate trigger current and holding current versus junction temperature.

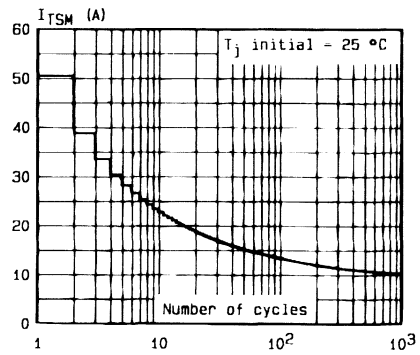

Fig.6 - Non repetitive surge peak on-state current versus number of cycles.

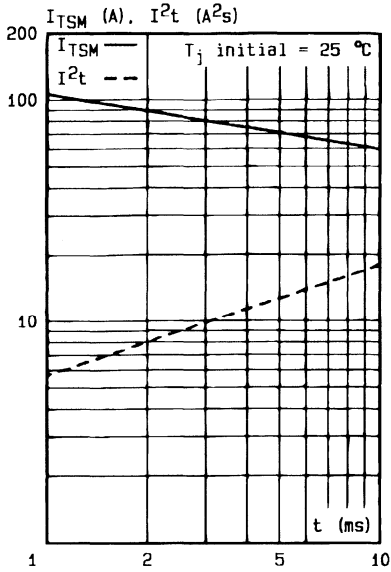

Fig.7 - Non repetitive surge peak on-state current for a sinusoidal pulse with width :  $t \leq 10$  ms, and corresponding value of  $I^2t$ .

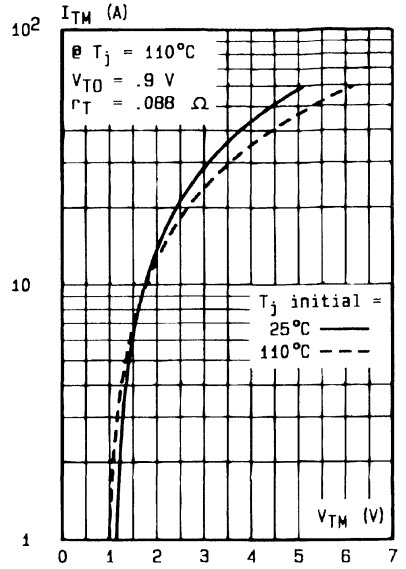
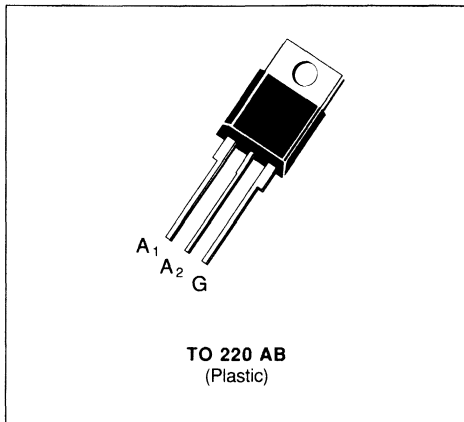

Fig.8 - On-state characteristics (maximum values).



**SENSITIVE GATE TRIACS**

- GLASS PASSIVATED CHIP
- $I_{GT}$  SPECIFIED IN FOUR QUADRANTS
- AVAILABLE IN INSULATED VERSION → BTA SERIES (INSULATING VOLTAGE 2500  $V_{RMS}$ ) OR IN UNINSULATED VERSION → BTB SERIES
- UL RECOGNIZED FOR BTA SERIES (E81734)

**DESCRIPTION**

New range suited for applications such as phase control and static switching.

**ABSOLUTE RATINGS** (limiting values)

Symbol	Parameter	Value	Unit
$I_{T(RMS)}$	RMS on-state Current (360° conduction angle)	$T_C = 75\text{ °C}$ 6	A
$I_{TSM}$	Non Repetitive Surge Peak on-state Current ( $T_j$ initial = 25 °C - Half sine wave)	$t = 8.3\text{ ms}$	63
		$t = 10\text{ ms}$	60
$I^2t$	$I^2t$ Value for Fusing	$t = 10\text{ ms}$	18
di/dt	Critical Rate of Rise of on-state Current (1)	Repetitive $F = 50\text{ Hz}$	10
		Non Repetitive	50
$T_{stg}$ $T_j$	Storage and Operating Junction Temperature Range	- 40 to 150	°C
		- 40 to 110	°C

Symbol	Parameter	BTA/BTB 06-					Unit
		200S	400S	600S	700S	800S	
$V_{DRM}$	Repetitive Peak off-state Voltage (2)	200	400	600	700	800	V

(1)  $I_G = 100\text{ mA}$      $di_c/dt = 1\text{ A}/\mu\text{s}$

(2)  $T_j = 110\text{ °C}$ .

**THERMAL RESISTANCES**

Symbol	Parameter	Value	Unit
$R_{th(j-a)}$	Junction to Ambient	60	°C/W
$R_{th(j-c)}\text{ DC}$	Junction to Case for DC	5.8	°C/W
$R_{th(j-c)}\text{ AC}$	Junction to Case for 360° Conduction Angle ( $F = 50\text{ Hz}$ )	4.3	°C/W



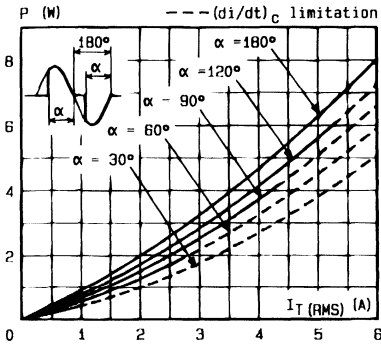

Fig.1 - Maximum mean power dissipation versus RMS on-state current ( $F = 60 \text{ Hz}$ ).

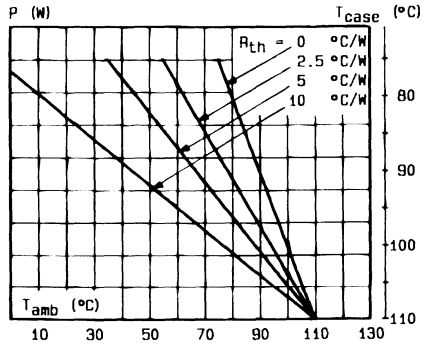

Fig.2 - Correlation between maximum mean power dissipation and maximum allowable temperatures ( $T_{amb}$  and  $T_{case}$ ) for different thermal resistances heatsink + contact.

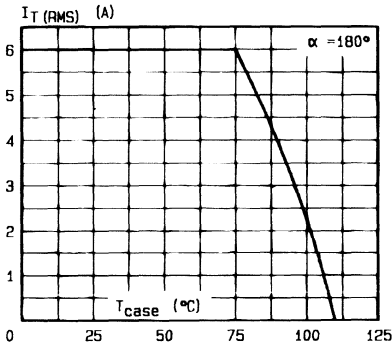

Fig.3 - RMS on-state current versus case temperature.

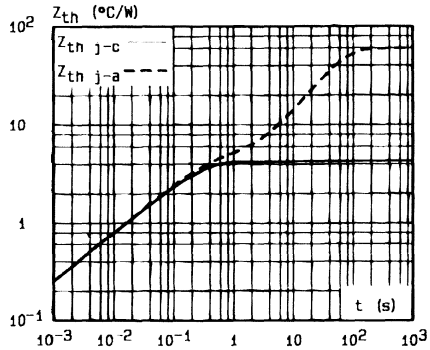

Fig.4 - Thermal transient impedance junction to case and junction to ambient versus pulse duration.

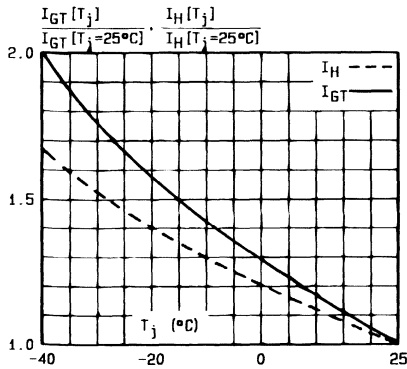

Fig.5 - Relative variation of gate trigger current and holding current versus junction temperature.

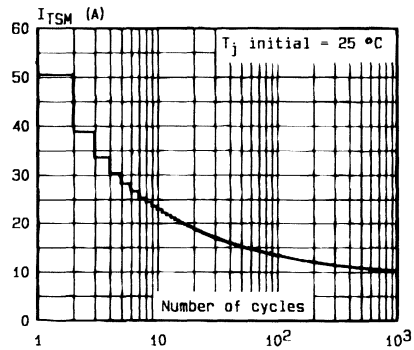

Fig.6 - Non repetitive surge peak on-state current versus number of cycles.

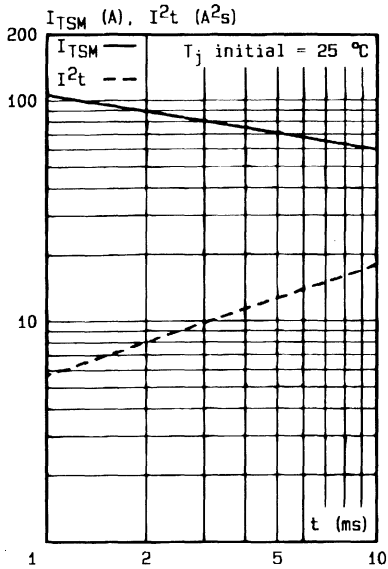

Fig.7 - Non repetitive surge peak on-state current for a sinusoidal pulse with width :  $t \leq 10$  ms, and corresponding value of  $I^2t$ .

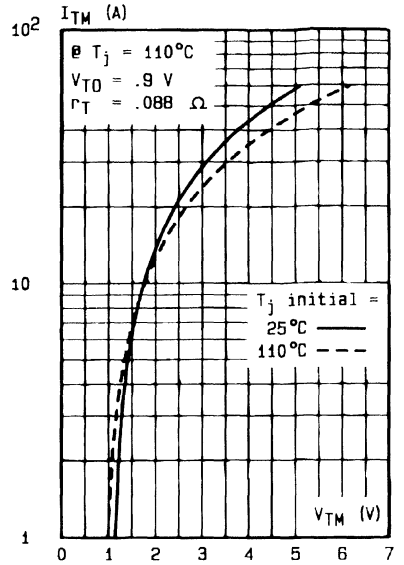

Fig.8 - On-state characteristics (maximum values).

**LOGIC LEVEL TRIACS**

- $I_{TRMS} = 6 \text{ A}$  at  $T_c = 80 \text{ }^\circ\text{C}$ .
- $V_{DRM} : 200 \text{ V}$  to  $800 \text{ V}$ .
- $I_{GT} = 10 \text{ mA}$  (QI-II-III).
- $(di/dt)_c = 3.5 \text{ A/ms}$  @  $(dv/dt)_c = 50 \text{ V}/\mu\text{s}$ .
- SUITED FOR LOW POWER TRIGGER CIRCUITS (INTEGRATED CIRCUITS AND MICROPROCESSORS).
- GLASS PASSIVATED CHIP.
- HIGH EFFICIENCY SWITCHING.
- AVAILABLE IN INSULATED VERSION → BTA SERIES (INSULATING VOLTAGE :  $2500 V_{RMS}$ ) OR IN UNINSULATED VERSION → BTB SERIES.
- UL RECOGNIZED FOR BTA SERIES (E81734).

**DESCRIPTION**

New range suited for applications such as phase control and static switching on inductive or resistive load.

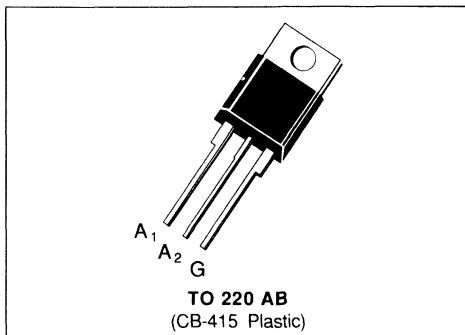
**ABSOLUTE RATINGS** (limiting values)

Symbol	Parameter		Value	Unit
$I_{TRMS}$	RMS on-state current (360 ° conduction angle)	$T_c = 80 \text{ }^\circ\text{C}$	6	A
$I_{TSM}$	Non repetitive surge peak on-state current ( $T_j$ initial = $25 \text{ }^\circ\text{C}$ )	$t = 8.3 \text{ ms}$	95	A
		$t = 10 \text{ ms}$	85	
$I^2t$	$I^2t$ value	$t = 10 \text{ ms}$	36	$\text{A}^2\text{s}$
$di/dt$	Critical rate of rise of on-state current (1)	Repetitive $F = 50 \text{ Hz}$	20	A / $\mu\text{s}$
		Non Repetitive	100	
$T_{stg}$ $T_j$	Storage and operating junction temperature range		- 40, + 150 - 40, + 110	$^\circ\text{C}$ $^\circ\text{C}$

Symbol	Parameter	BTA/BTB 06-					Unit
		200 SW	400 SW	600 SW	700 SW	800 SW	
$V_{DRM}$	Repetitive peak off-state voltage (2)	± 200	± 400	± 600	± 700	± 800	V

(1) Gate supply :  $I_G = 100 \text{ mA}$  -  $di_G/dt = 1 \text{ A}/\mu\text{s}$ .

(2)  $T_j = 110 \text{ }^\circ\text{C}$ .

**THERMAL RESISTANCES**

Symbol	Parameter	Value	Unit
$R_{th(j-a)}$	Junction to ambient	60	°C/W
$R_{th(j-c)} DC$	Junction to case for DC	4.8	°C/W
$R_{th(j-c)} AC$	Junction to case for 360° conduction angle (F = 50 Hz)	3.6	°C/W

**GATE CHARACTERISTICS (maximum values)**
 $P_{GM} = 40 \text{ W (} t = 10 \mu\text{s)}$     $P_{G(AV)} = 1 \text{ W}$     $I_{GM} = 4 \text{ A (} t = 10 \mu\text{s)}$     $V_{GM} = 16 \text{ V (} t = 10 \mu\text{s)}$ .

**ELECTRICAL CHARACTERISTICS**

Symbol	Test Conditions			Quadrants	Min.	Typ.	Max.	Unit
$I_{GT}$	$T_j = 25 \text{ °C}$ Pulse duration > 20 $\mu\text{s}$	$V_D = 12 \text{ V}$	$R_L = 33 \text{ }\Omega$	I-II-III			10	mA
$V_{GT}$	$T_j = 25 \text{ °C}$ Pulse duration > 20 $\mu\text{s}$	$V_D = 12 \text{ V}$	$R_L = 33 \text{ }\Omega$	I-II-III			1.5	V
$V_{GD}$	$T_j = 110 \text{ °C}$ Pulse duration > 20 $\mu\text{s}$	$V_D = V_{DRM}$	$R_L = 3.3 \text{ k}\Omega$	I-II-III	0.2			V
$I_H^*$	$T_j = 25 \text{ °C}$ Gate open	$I_T = 100 \text{ mA}$ $R_L = 140 \text{ }\Omega$					25	mA
$I_L$	$T_j = 25 \text{ °C}$ Pulse duration > 20 $\mu\text{s}$	$V_D = 12 \text{ V}$	$R_L = 33 \text{ }\Omega$ $I_G = 50 \text{ mA}$	I-III		25		mA
				II		50		
$V_{TM}^*$	$T_j = 25 \text{ °C}$	$I_{TM} = 8.5 \text{ A}$	$t_p = 10 \text{ ms}$				1.75	V
$I_{DRM}^*$	$T_j = 25 \text{ °C}$	$V_{DRM}$ rated	Gate open				10	$\mu\text{A}$
	$T_j = 110 \text{ °C}$						500	
$dv/dt^*$	$T_j = 110 \text{ °C}$	Gate open Linear slope up to 0.67 $V_{DRM}$			50			$V/\mu\text{s}$
$(di/dt)_c^*$	$T_j = 110 \text{ °C}$	$(dv/dt)_c = 0.1 \text{ V}/\mu\text{s}$			3.5	5		A/ms
	$T_j = 110 \text{ °C}$	$(dv/dt)_c = 50 \text{ V}/\mu\text{s}$			2.7	3.5		
$t_{gt}$	$T_j = 25 \text{ °C}$ $I_T = 8.5 \text{ A}$	$di_G/dt = 1 \text{ A}/\mu\text{s}$ $V_D = V_{DRM}$	$I_G = 50 \text{ mA}$	I-II-III		2		$\mu\text{s}$

\* For either polarity of electrode A<sub>2</sub> voltage with reference to electrode A<sub>1</sub>.

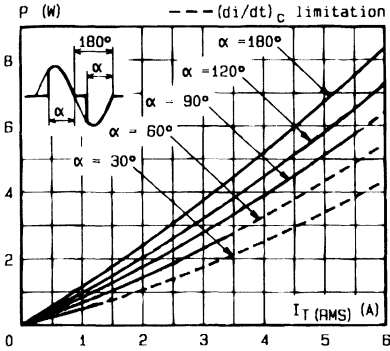

Fig. 1 - Maximum mean power dissipation versus RMS on-state current ( $f = 60$  Hz).

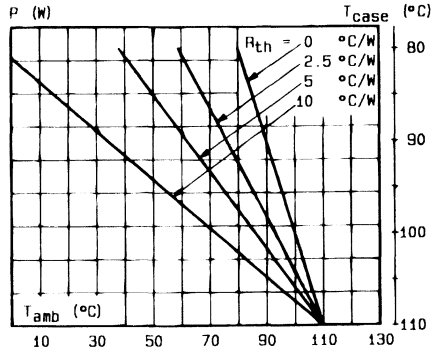

Fig. 2 - Correlation between maximum mean power dissipation and maximum allowable temperatures ( $T_{amb}$  and  $T_{case}$ ) for different thermal resistances heatsink + contact.

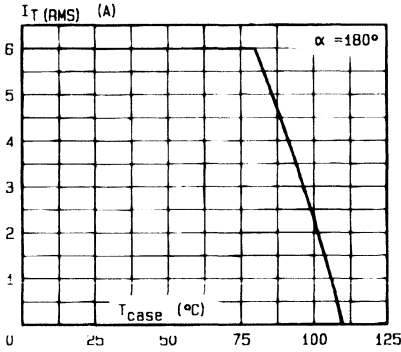

Fig. 3 - RMS on-state current versus case temperature.

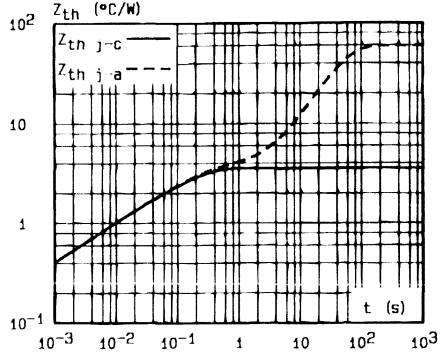

Fig. 4 - Thermal transient impedance junction to case and junction to ambient versus pulse duration.

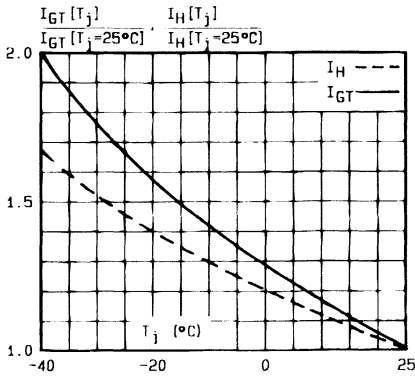

Fig. 5 - Relative variation of gate trigger current and holding current versus junction temperature.

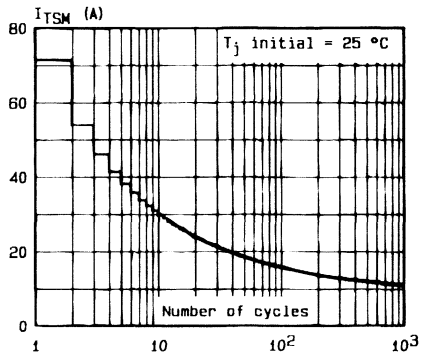

Fig. 6 - Non repetitive surge peak on-state current versus number of cycles.

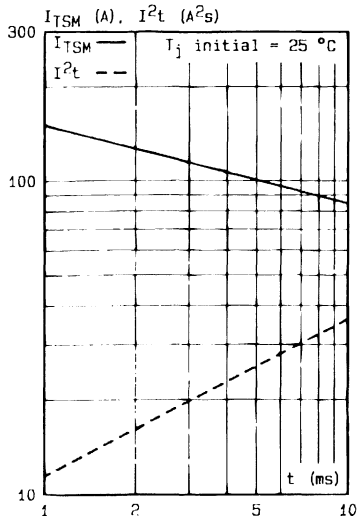

Fig.7 - Non repetitive surge peak on-state current for a sinusoidal pulse with width :  $t \leq 10 \text{ ms}$ , and corresponding value of  $I^2t$ .

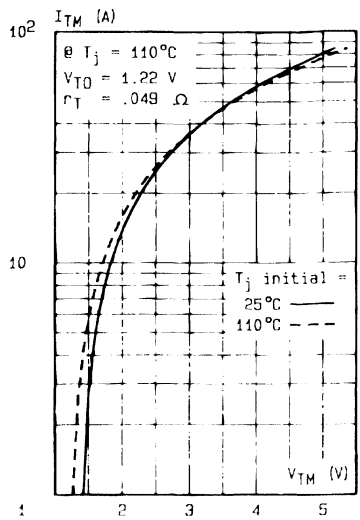

Fig.8 - On-state characteristics (maximum values).

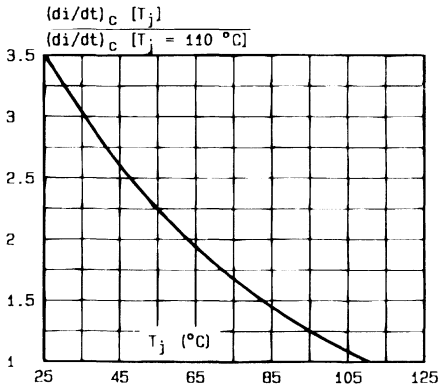

Fig.9 - Relative variation of  $(di/dt)_C$  versus junction temperature.

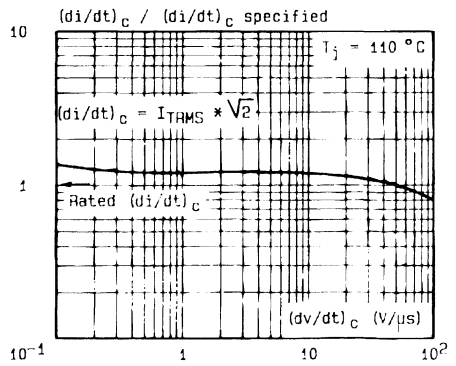
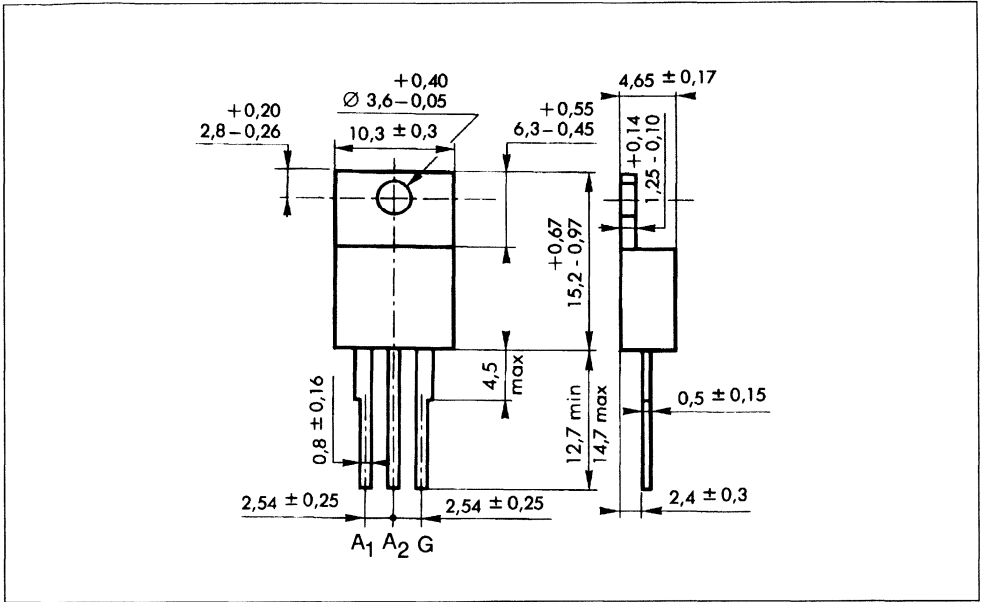

Fig.10 - Relative variation of  $(di/dt)_C$  versus  $(dv/dt)_C$  (inductive load) (typical values).



## PACKAGE MECHANICAL DATA

TO 220 AB (CB-415) Plastic



Cooling method : by conduction (method C)

Marking : type number

Weight : 2 g



## SENSITIVE GATE TRIACS

- GLASS PASSIVATED CHIP
- $I_{GT}$  SPECIFIED IN FOUR QUADRANTS
- AVAILABLE IN INSULATED VERSION → BTA SERIES (INSULATING VOLTAGE 2500  $V_{RMS}$ ) OR IN UNINSULATED VERSION → BTB SERIES
- UL RECOGNIZED FOR BTA SERIES (E81734)

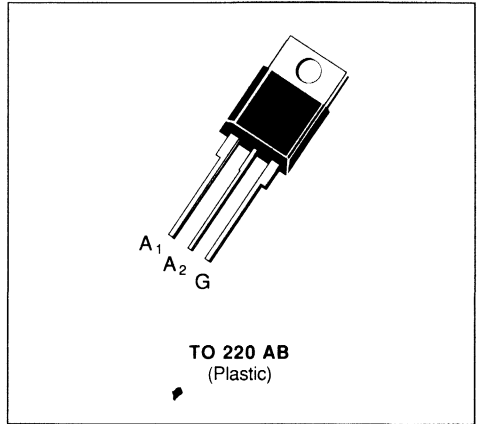

### DESCRIPTION

New range suited for applications such as phase control and static switching.

### ABSOLUTE RATINGS (limiting values)

Symbol	Parameter	Value	Unit
$I_{T(RMS)}$	RMS on-state Current (360° conduction angle) $T_C = 75\text{ °C}$	6	A
$I_{TSM}$	Non Repetitive Surge Peak on-state Current ( $T_J$ initial = 25 °C - Half sine wave)	$t = 8.3\text{ ms}$	63
		$t = 10\text{ ms}$	60
$I^2t$	$I^2t$ Value for Fusing	$t = 10\text{ ms}$	$A^2s$
$di/dt$	Critical Rate of Rise of on-state Current (1)	Repetitive $F = 50\text{ Hz}$	10
		Non Repetitive	50
$T_{stg}$ $T_J$	Storage and Operating Junction Temperature Range	- 40 to 150	°C
		- 40 to 110	°C

Symbol	Parameter	BTA/BTB 06-					Unit
		200T	400T	600T	700T	800T	
$V_{DRM}$	Repetitive Peak off-state Voltage (2)	200	400	600	700	800	V

(1)  $I_G = 50\text{ mA}$   $di/dt = 1\text{ A}/\mu\text{s}$

(2)  $T_J = 110\text{ °C}$ .

### THERMAL RESISTANCES

Symbol	Parameter	Value	Unit
$R_{th(j-a)}$	Junction to Ambient	60	°C/W
$R_{th(j-c)}\text{ DC}$	Junction to Case for DC	5.8	°C/W
$R_{th(j-c)}\text{ AC}$	Junction to Case for 360 ° Conduction Angle ( $F = 50\text{ Hz}$ )	4.3	°C/W

**GATE CHARACTERISTICS** (maximum values)

$P_{GM} = 40 \text{ W}$  ( $t_p = 10 \mu\text{s}$ )

$I_{GM} = 4 \text{ A}$  ( $t_p = 10 \mu\text{s}$ )

$P_{G(AV)} = 1 \text{ W}$

$V_{GM} = 16 \text{ V}$  ( $t_p = 10 \mu\text{s}$ )

**ELECTRICAL CHARACTERISTICS**

Symbol	Test Conditions			Quadrants	Min.	Typ.	Max.	Unit
$I_{GT}$	$T_j = 25 \text{ }^\circ\text{C}$ Pulse Duration > 20 $\mu\text{s}$	$V_D = 12 \text{ V}$	$R_L = 33 \text{ } \Omega$	I-II-III-IV			5	mA
$V_{GT}$	$T_j = 25 \text{ }^\circ\text{C}$ Pulse Duration > 20 $\mu\text{s}$	$V_D = 12 \text{ V}$	$R_L = 33 \text{ } \Omega$	I-II-III-IV			1.5	V
$V_{GD}$	$T_j = 110 \text{ }^\circ\text{C}$	$V_D = V_{DRM}$	$R_L = 3.3 \text{ k}\Omega$	I-II-III-IV	0.2			V
$I_{H^*}$	$T_j = 25 \text{ }^\circ\text{C}$	$I_T = 100 \text{ mA}$	Gate Open				15	mA
$I_L$	$T_j = 25 \text{ }^\circ\text{C}$ Pulse Duration > 20 $\mu\text{s}$	$V_D = 12 \text{ V}$	$I_G = 10 \text{ mA}$	I-III-IV		15		mA
				II		30		
$V_{TM}^*$	$T_j = 25 \text{ }^\circ\text{C}$	$I_{TM} = 8.5 \text{ A}$	$t_p = 10 \text{ ms}$				1.65	V
$I_{DRM}^*$	$V_{DRM}$ Specified	$T_j = 25 \text{ }^\circ\text{C}$	$T_j = 110 \text{ }^\circ\text{C}$				0.01	mA
							0.75	
$dv/dt^*$	$T_j = 110 \text{ }^\circ\text{C}$	Gate Open Linear Slope up to $V_D = 67\% V_{DRM}$				10		V/ $\mu\text{s}$
$(dv/dt)_c^*$	$T_C = 75 \text{ }^\circ\text{C}$ $(di/dt)_c = 2.7 \text{ A/ms}$	$V_D = V_{DRM}$	$I_T = 8.5 \text{ A}$			1		V/ $\mu\text{s}$
$t_{gt}$	$T_j = 25 \text{ }^\circ\text{C}$ $I_G = 20 \text{ mA}$	$V_D = V_{DRM}$ $di_G/dt = 0.25 \text{ A}/\mu\text{s}$	$I_T = 8.5 \text{ A}$	I-II-III-IV		2		$\mu\text{s}$

\* For either polarity of electrode  $A_2$  voltage with reference to electrode  $A_1$ .

**PACKAGE MECHANICAL DATA**

TO 220 AB Plastic

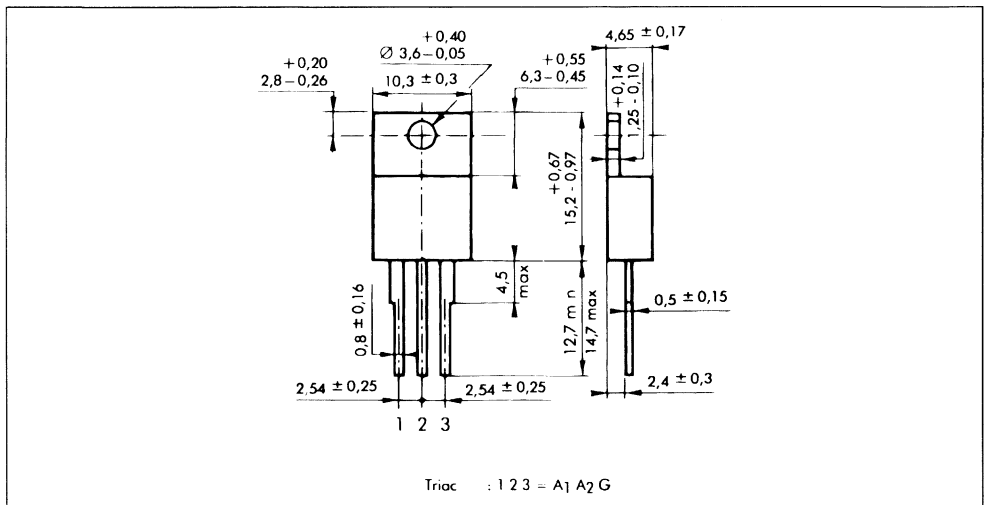

Cooling method : by conduction (method C)

Marking : type number

Weight : 2 g.

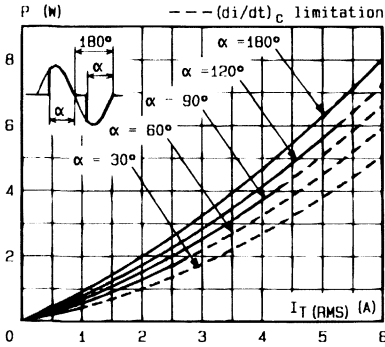

Fig. 1 - Maximum mean power dissipation versus RMS on-state current ( $F = 60$  Hz).

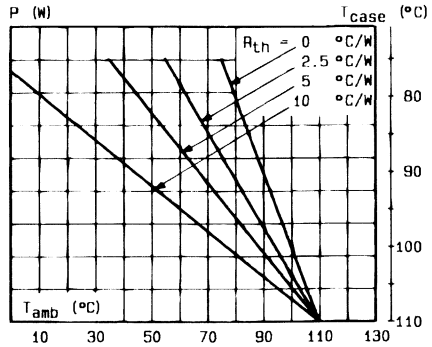

Fig. 2 - Correlation between maximum mean power dissipation and maximum allowable temperatures ( $T_{amb}$  and  $T_{case}$ ) for different thermal resistances heatsink + contact.

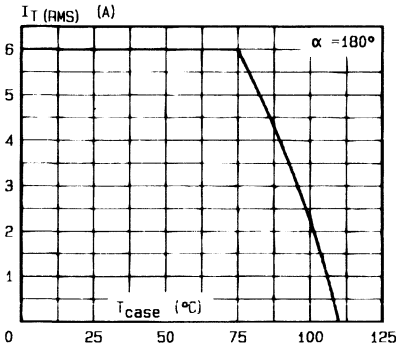

Fig. 3 - RMS on-state current versus case temperature.

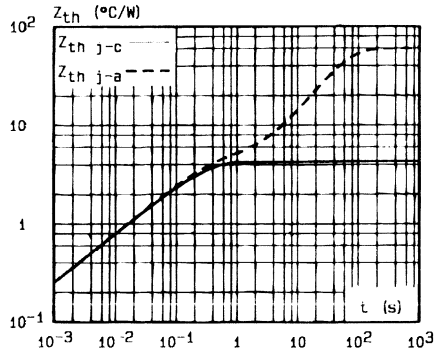

Fig. 4 - Thermal transient impedance junction to case and junction to ambient versus pulse duration.

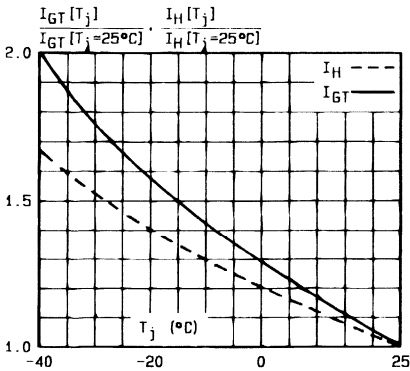

Fig. 5 - Relative variation of gate trigger current and holding current versus junction temperature.

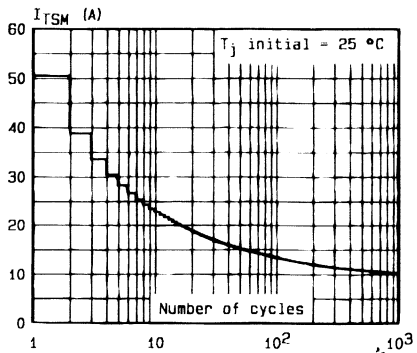

Fig. 6 - Non repetitive surge peak on-state current versus number of cycles.

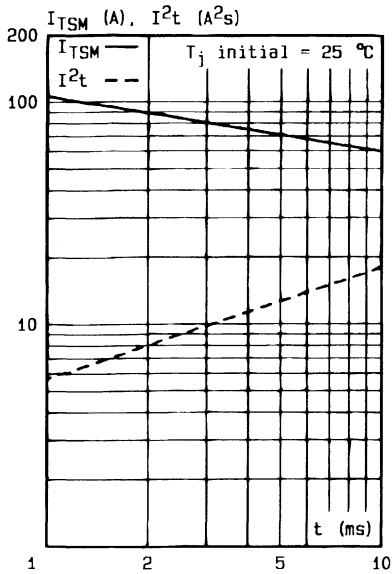

Fig.7 - Non repetitive surge peak on-state current for a sinusoidal pulse with width :  $t \leq 10$  ms, and corresponding value of  $I^2t$ .

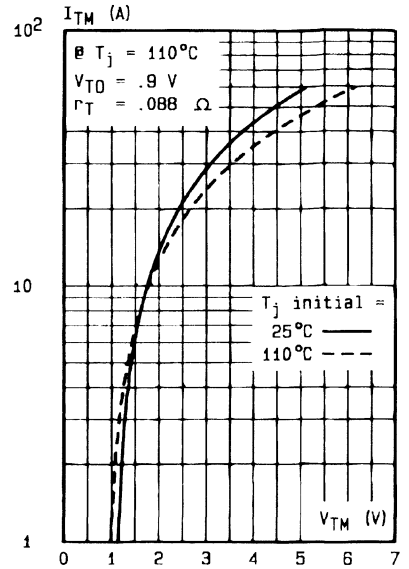

Fig.8 - On-state characteristics (maximum values).

**LOGIC LEVEL TRIACS**

- $I_{TRMS} = 6 \text{ A}$  at  $T_c = 80 \text{ }^\circ\text{C}$ .
- $V_{DRM} : 200 \text{ V}$  to  $800 \text{ V}$ .
- $I_{GT} = 5 \text{ mA}$  (QI-II-III).
- $(di/dt)_c = 2.7 \text{ A/ms}$  @  $(dv/dt)_c = 20 \text{ V}/\mu\text{s}$ .
- SUITED FOR LOW POWER TRIGGER CIRCUITS (INTEGRATED CIRCUITS AND MICROPROCESSORS).
- GLASS PASSIVATED CHIP.
- HIGH EFFICIENCY SWITCHING.
- AVAILABLE IN INSULATED VERSION → BTA SERIES (INSULATING VOLTAGE :  $2500 V_{RMS}$ ) OR IN UNINSULATED VERSION → BTB SERIES.
- UL RECOGNIZED FOR BTA SERIES (E81734).

**DESCRIPTION**

New range suited for applications such as phase control and static switching on inductive or resistive load.

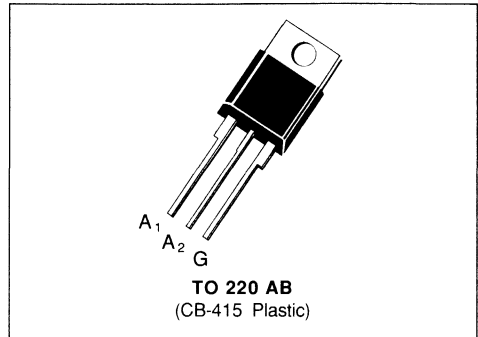
**ABSOLUTE RATINGS** (limiting values)

Symbol	Parameter		Value	Unit
$I_{TRMS}$	RMS on-state current (360 ° conduction angle)	$T_c = 80 \text{ }^\circ\text{C}$	6	A
$I_{TSM}$	Non repetitive surge peak on-state current ( $T_j$ initial = $25 \text{ }^\circ\text{C}$ )	$t = 8.3 \text{ ms}$	95	A
		$t = 10 \text{ ms}$	85	
$I^2 t$	$I^2 t$ value	$t = 10 \text{ ms}$	36	$\text{A}^2 \text{ s}$
$di/dt$	Critical rate of rise of on-state current (1)	Repetitive $F = 50 \text{ Hz}$	20	A / $\mu\text{s}$
		Non Repetitive	100	
$T_{stg}$ $T_j$	Storage and operating junction temperature range		- 40, + 150 - 40, + 110	$^\circ\text{C}$ $^\circ\text{C}$

Symbol	Parameter	BTA/BTB 06-					Unit
		200 TW	400 TW	600 TW	700 TW	800 TW	
$V_{DRM}$	Repetitive peak off-state voltage (2)	$\pm 200$	$\pm 400$	$\pm 600$	$\pm 700$	$\pm 800$	V

(1) Gate supply :  $I_G = 50 \text{ mA}$  –  $di_G/dt = 1 \text{ A}/\mu\text{s}$ .

(2)  $T_j = 110 \text{ }^\circ\text{C}$ .

**THERMAL RESISTANCES**

Symbol	Parameter	Value	Unit
$R_{th(j-a)}$	Junction to ambient	60	°C/W
$R_{th(j-c)}$ DC	Junction to case for DC	4.8	°C/W
$R_{th(j-c)}$ AC	Junction to case for 360 ° conduction angle (F = 50 Hz)	3.6	°C/W

**GATE CHARACTERISTICS (maximum values)**
 $P_{GM} = 40 \text{ W (} t = 10 \mu\text{s)}$     $P_{G(AV)} = 1 \text{ W}$     $I_{GM} = 4 \text{ A (} t = 10 \mu\text{s)}$     $V_{GM} = 16 \text{ V (} t = 10 \mu\text{s)}$ .

**ELECTRICAL CHARACTERISTICS**

Symbol	Test Conditions			Quadrants	Min.	Typ.	Max.	Unit
$I_{GT}$	$T_j = 25 \text{ °C}$	$V_D = 12 \text{ V}$	$R_L = 33 \Omega$	I-II-III			5	mA
	Pulse duration > 20 $\mu\text{s}$							
$V_{GT}$	$T_j = 25 \text{ °C}$	$V_D = 12 \text{ V}$	$R_L = 33 \Omega$	I-II-III			1.5	V
	Pulse duration > 20 $\mu\text{s}$							
$V_{GD}$	$T_j = 110 \text{ °C}$	$V_D = V_{DRM}$	$R_L = 3.3 \text{ k}\Omega$	I-II-III	0.2			V
	Pulse duration > 20 $\mu\text{s}$							
$I_H^*$	$T_j = 25 \text{ °C}$	$I_T = 100 \text{ mA}$	$R_L = 140 \Omega$				15	mA
	Gate open							
$I_L$	$T_j = 25 \text{ °C}$	$V_D = 12 \text{ V}$	$R_L = 33 \Omega$	I-III		15		mA
				II		30		
	Pulse duration > 20 $\mu\text{s}$							
$V_{TM}^*$	$T_j = 25 \text{ °C}$	$I_{TM} = 8.5 \text{ A}$	$t_p = 10 \text{ ms}$				1.75	V
$I_{DRM}^*$	$T_j = 25 \text{ °C}$	$V_{DRM}$ rated	Gate open				10	$\mu\text{A}$
	$T_j = 110 \text{ °C}$						500	
$dv/dt^*$	$T_j = 110 \text{ °C}$	Gate open			20			V/ $\mu\text{s}$
	Linear slope up to 0.67 $V_{DRM}$							
$(di/dt)_c^*$	$T_j = 110 \text{ °C}$	$(dv/dt)_c = 0.1 \text{ V}/\mu\text{s}$			2.7	4		A/ms
	$T_j = 110 \text{ °C}$	$(dv/dt)_c = 20 \text{ V}/\mu\text{s}$			1.3	2.7		
$t_{gt}$	$T_j = 25 \text{ °C}$	$di_G/dt = 1 \text{ A}/\mu\text{s}$	$I_G = 25 \text{ mA}$	I-II-III		2		$\mu\text{s}$
	$I_T = 8.5 \text{ A}$	$V_D = V_{DRM}$						

\* For either polarity of electrode A<sub>2</sub> voltage with reference to electrode A<sub>1</sub>.



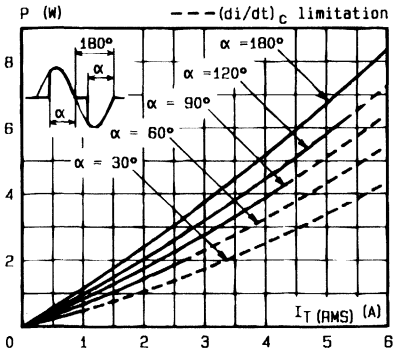

Fig. 1 - Maximum mean power dissipation versus RMS on-state current ( $F = 60$  Hz).

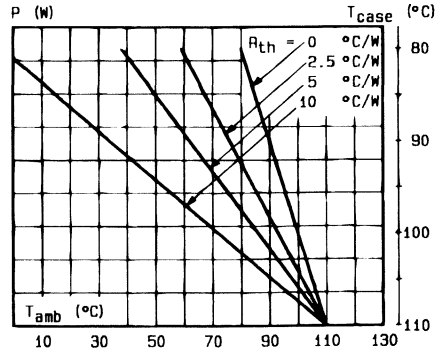

Fig. 2 - Correlation between maximum mean power dissipation and maximum allowable temperatures ( $T_{amb}$  and  $T_{case}$ ) for different thermal resistances heatsink + contact.

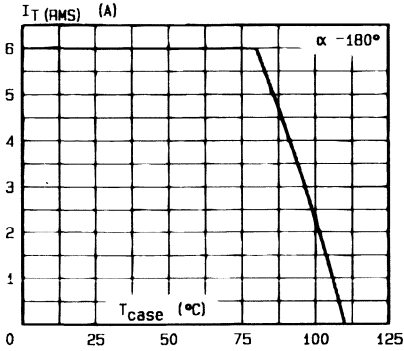

Fig. 3 - RMS on-state current versus case temperature.

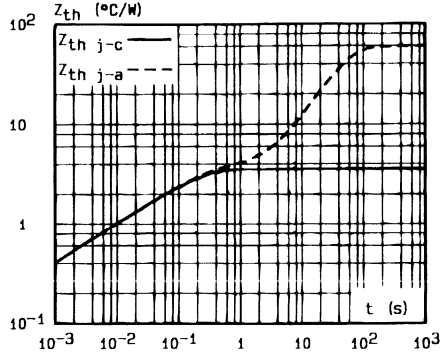

Fig. 4 - Thermal transient impedance junction to case and junction to ambient versus pulse duration.

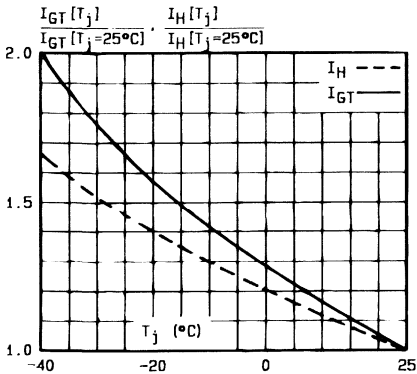

Fig. 5 - Relative variation of gate trigger current and holding current versus junction temperature.

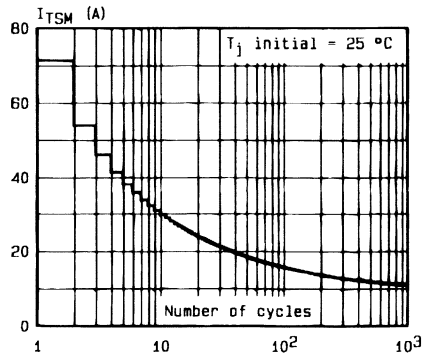

Fig. 6 - Non repetitive surge peak on-state current versus number of cycles.

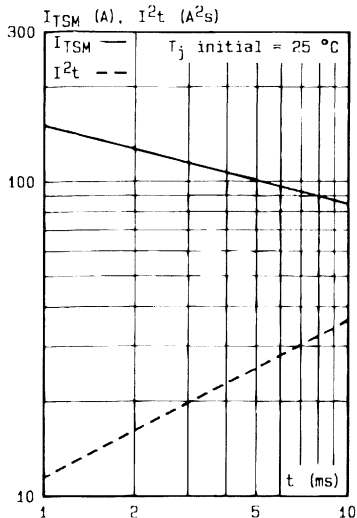

Fig.7 - Non repetitive surge peak on-state current for a sinusoidal pulse with width :  $t \leq 10$  ms, and corresponding value of  $I^2t$ .

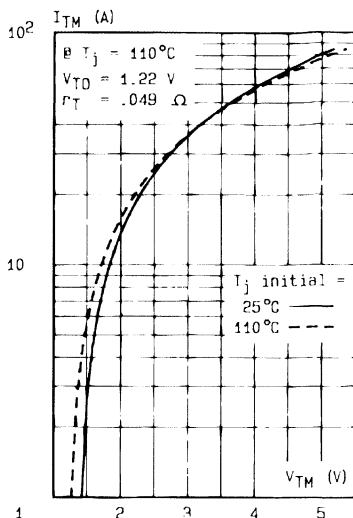

Fig.8 - On-state characteristics (maximum values).

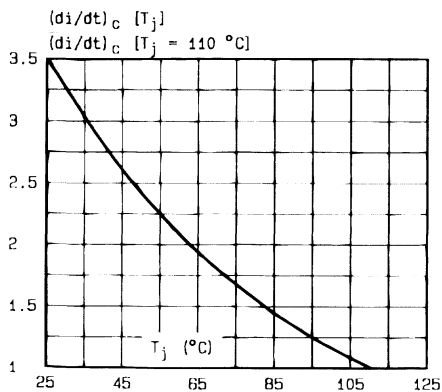

Fig.9 - Relative variation of  $(di/dt)_C$  versus junction temperature.

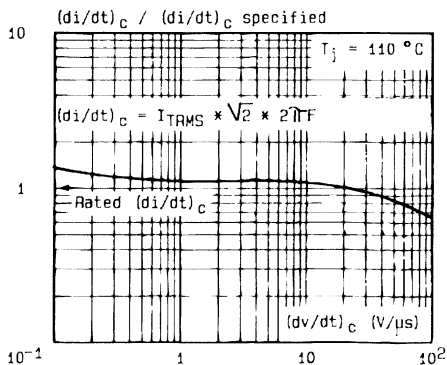
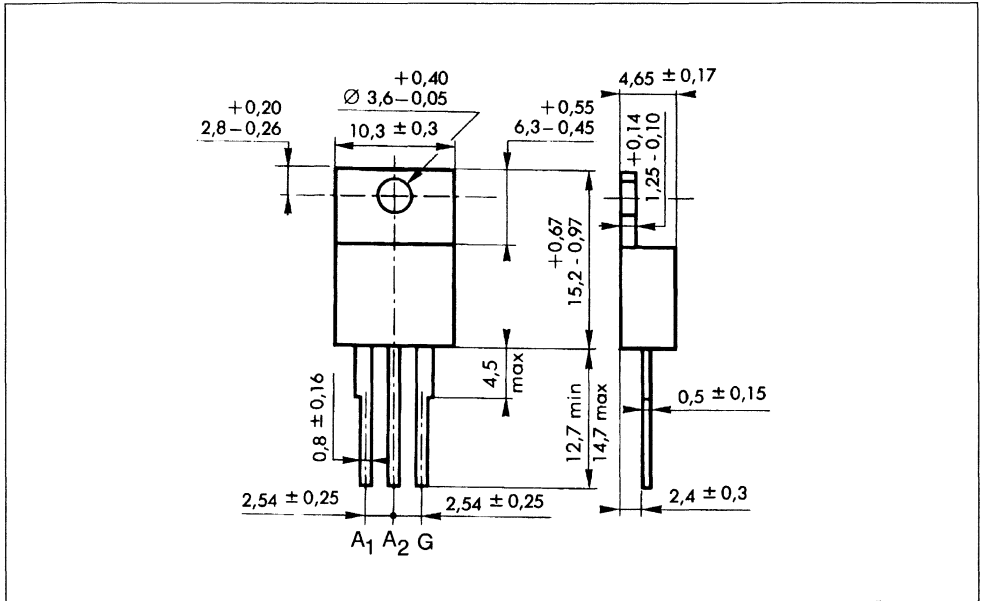

Fig.10 - Relative variation of  $(di/dt)_C$  versus  $(dv/dt)_C$  (inductive load) (typical values).

## PACKAGE MECHANICAL DATA

TO 220 AB (CB-415) Plastic



Cooling method : by conduction (method C)

Marking : type number

Weight : 2 g



**SENSITIVE GATE TRIACS**

- GLASS PASSIVATED CHIP
- I<sub>GT</sub> SPECIFIED IN FOUR QUADRANTS
- AVAILABLE IN INSULATED VERSION → BTA SERIES (INSULATING VOLTAGE 2500 V<sub>RMS</sub>) OR IN UNINSULATED VERSION → BTB SERIES
- UL RECOGNIZED FOR BTA SERIES (E81734)

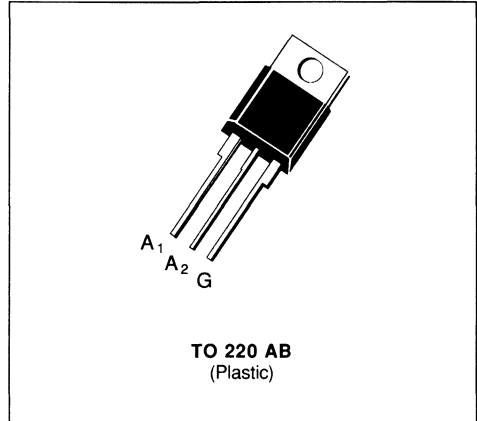
**DESCRIPTION**

New range suited for applications such as phase control and static switching.

**ABSOLUTE RATINGS** (limiting values)

Symbol	Parameter	Value	Unit
I <sub>T(RMS)</sub>	RMS on-state Current (360° conduction angle)	T <sub>C</sub> = 75 °C 8	A
I <sub>TSM</sub>	Non Repetitive Surge Peak on-state Current (T <sub>J</sub> initial = 25 °C - Half sine wave)	t = 8.3 ms	84
		t = 10 ms	80
I <sup>2</sup> t	I <sup>2</sup> t Value for Fusing	t = 10 ms	32
di/dt	Critical Rate of Rise of on-state Current (1)	Repetitive F = 50 Hz	10
		Non Repetitive	50
T <sub>stg</sub> T <sub>J</sub>	Storage and Operating Junction Temperature Range	- 40 to 150	°C
		- 40 to 110	°C

Symbol	Parameter	BTA/BTB 08-					Unit
		200A	400A	600A	700A	800A	
V <sub>DRM</sub>	Repetitive Peak off-state Voltage (2)	200	400	600	700	800	V

(1) I<sub>G</sub> = 250 mA    di/dt = 1 A/μs

(2) T<sub>J</sub> = 110 °C.

**THERMAL RESISTANCES**

Symbol	Parameter	Value	Unit
R <sub>th(j-a)</sub>	Junction to Ambient	60	°C/W
R <sub>th(j-c) DC</sub>	Junction to Case for DC	5.1	°C/W
R <sub>th(j-c) AC</sub>	Junction to Case for 360 ° Conduction Angle (F = 50 Hz)	3.8	°C/W

**GATE CHARACTERISTICS** (maximum values)

$P_{GM} = 40 \text{ W}$  ( $t_p = 10 \mu\text{s}$ )       $I_{GM} = 4 \text{ A}$  ( $t_p = 10 \mu\text{s}$ )  
 $P_G(AV) = 1 \text{ W}$        $V_{GM} = 16 \text{ V}$  ( $t_p = 10 \mu\text{s}$ )

**ELECTRICAL CHARACTERISTICS**

Symbol	Test Conditions			Quadrants	Min.	Typ.	Max.	Unit
$I_{GT}$	$T_j = 25 \text{ }^\circ\text{C}$ Pulse Duration > 20 $\mu\text{s}$	$V_D = 12 \text{ V}$	$R_L = 33 \text{ } \Omega$	I-II-III			10	mA
				IV			25	
$V_{GT}$	$T_j = 25 \text{ }^\circ\text{C}$ Pulse Duration > 20 $\mu\text{s}$	$V_D = 12 \text{ V}$	$R_L = 33 \text{ } \Omega$	I-II-III-IV			1.5	V
$V_{GD}$	$T_j = 110 \text{ }^\circ\text{C}$	$V_D = V_{DRM}$	$R_L = 3.3 \text{ k}\Omega$	I-II-III-IV	0.2			V
$I_{H^*}$	$T_j = 25 \text{ }^\circ\text{C}$	$I_T = 100 \text{ mA}$	Gate Open				25	mA
$I_L$	$T_j = 25 \text{ }^\circ\text{C}$ Pulse Duration > 20 $\mu\text{s}$	$V_D = 12 \text{ V}$	$I_G = 50 \text{ mA}$	I-III-IV		25		mA
				II		50		
$V_{TM}^*$	$T_j = 25 \text{ }^\circ\text{C}$	$I_{TM} = 11 \text{ A}$	$t_p = 10 \text{ ms}$				1.75	V
$I_{DRM}^*$	$V_{DRM}$ Specified	$T_j = 25 \text{ }^\circ\text{C}$					0.01	mA
		$T_j = 110 \text{ }^\circ\text{C}$					0.5	
dv/dt*	$T_j = 110 \text{ }^\circ\text{C}$	Gate Open			10			V/ $\mu\text{s}$
(dv/dt) <sub>c</sub> *	$T_c = 75 \text{ }^\circ\text{C}$ (di/dt) <sub>c</sub> = 3.5 A/ms	$V_D = V_{DRM}$	$I_T = 11 \text{ A}$			5		V/ $\mu\text{s}$
t <sub>gt</sub>	$T_j = 25 \text{ }^\circ\text{C}$	$V_D = V_{DRM}$	$I_T = 11 \text{ A}$ $I_G = 40 \text{ mA}$	I-II-III-IV		2		$\mu\text{s}$

\* For either polarity of electrode A<sub>2</sub> voltage with reference to electrode A<sub>1</sub>.

**PACKAGE MECHANICAL DATA**

TO 220 AB Plastic

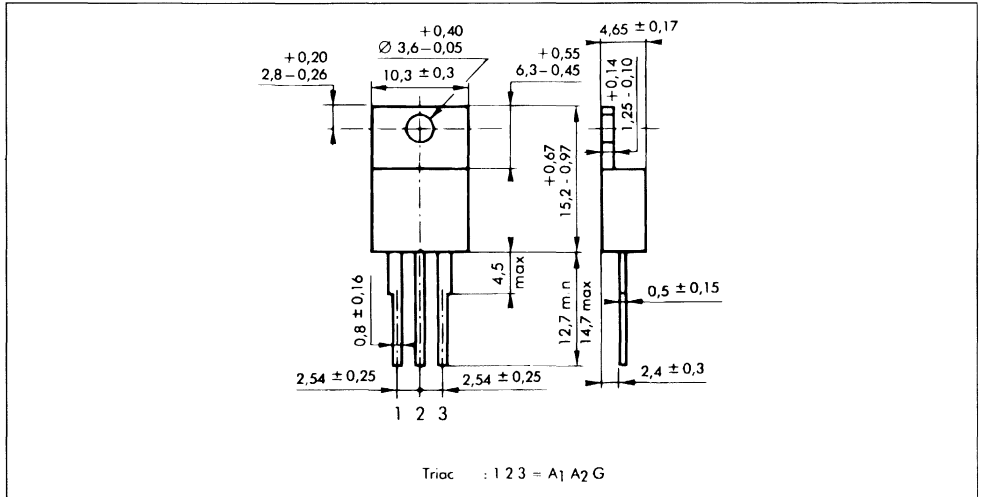

Cooling method : by conduction (method C)

Marking : type number

Weight : 2 g

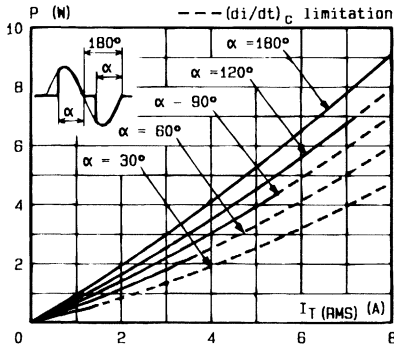

Fig. 1 - Maximum mean power dissipation versus RMS on-state current ( $F = 60$  Hz).

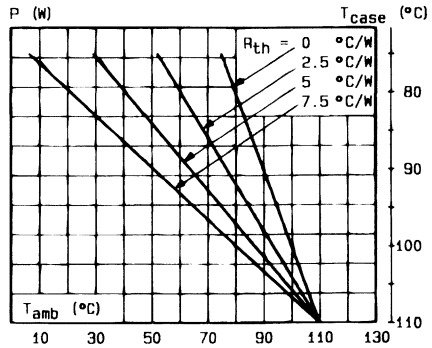

Fig. 2 - Correlation between maximum mean power dissipation and maximum allowable temperatures ( $T_{amb}$  and  $T_{case}$ ) for different thermal resistances heatsink + contact.

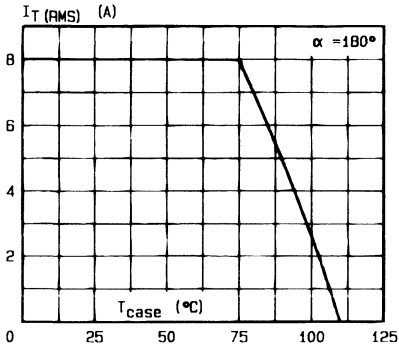

Fig. 3 - RMS on-state current versus case temperature.

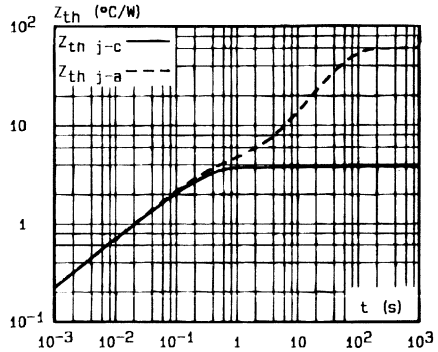

Fig. 4 - Thermal transient impedance junction to case and junction to ambient versus pulse duration.

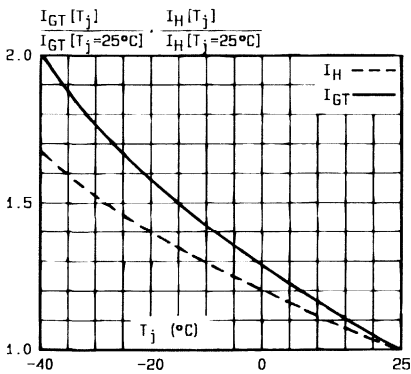

Fig. 5 - Relative variation of gate trigger current and holding current versus junction temperature.

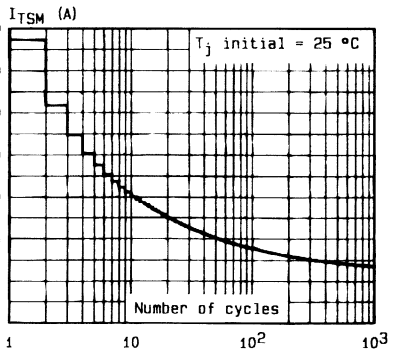

Fig. 6 - Non repetitive surge peak on-state current versus number of cycles.

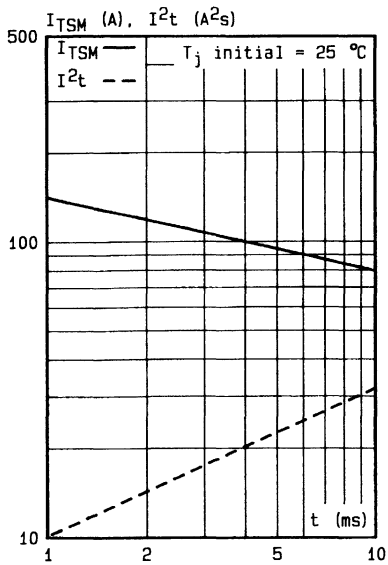

Fig.7 - Non repetitive surge peak on-state current for a sinusoidal pulse with width :  $t \leq 10$  ms, and corresponding value of  $I^2t$ .

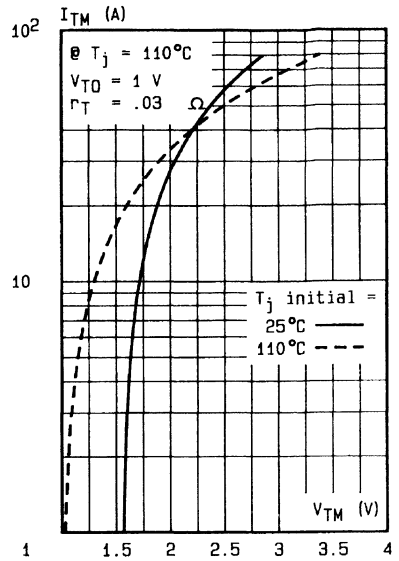
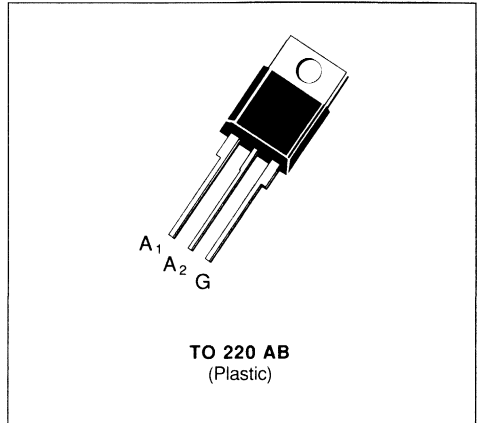

Fig.8 - On-state characteristics (maximum values).



## TRIACS

- GLASS PASSIVATED CHIP
- EXCELLENT  $(dv/dt)_c > 10 \text{ V}/\mu\text{s}$
- $I_{GT}$  SPECIFIED IN FOUR QUADRANTS
- AVAILABLE IN INSULATED VERSION → BTA SERIES (INSULATING VOLTAGE 2500  $V_{RMS}$ ) OR IN UNINSULATED VERSION → BTB SERIES
- UL RECOGNIZED FOR BTA SERIES (E81734)



### DESCRIPTION

New range suited for applications such as phase control and static switching.

### ABSOLUTE RATINGS (limiting values)

Symbol	Parameter	Value	Unit	
$I_{T(RMS)}$	RMS on-state Current (360° conduction angle) $T_C = 75 \text{ }^\circ\text{C}$	8	A	
$I_{TSM}$	Non Repetitive Surge Peak on-state Current ( $T_j$ initial = 25 $^\circ\text{C}$ - Half sine wave)	$t = 8.3 \text{ ms}$	84	A
		$t = 10 \text{ ms}$	80	
$I^2t$	$I^2t$ Value for Fusing $t = 10 \text{ ms}$	32	$\text{A}^2\text{s}$	
$di/dt$	Critical Rate of Rise of on-state Current (1)	Repetitive $F = 50 \text{ Hz}$	10	$\text{A}/\mu\text{s}$
		Non Repetitive	50	
$T_{stg}$ $T_j$	Storage and Operating Junction Temperature Range	- 40 to 150 - 40 to 110	$^\circ\text{C}$ $^\circ\text{C}$	

Symbol	Parameter	BTA/BTB 08-					Unit
		200B	400B	600B	700B	800B	
$V_{DRM}$	Repetitive Peak off-state Voltage (2)	200	400	600	700	800	V

(1)  $I_G = 1 \text{ A}$   $di_G/dt = 1 \text{ A}/\mu\text{s}$

(2)  $T_j = 110 \text{ }^\circ\text{C}$ .

### THERMAL RESISTANCES

Symbol	Parameter	Value	Unit
$R_{th(j-a)}$	Junction to Ambient	60	$^\circ\text{C}/\text{W}$
$R_{th(j-c)} \text{ DC}$	Junction to Case for DC	4.3	$^\circ\text{C}/\text{W}$
$R_{th(j-c)} \text{ AC}$	Junction to Case for 360° Conduction Angle ( $F = 50 \text{ Hz}$ )	3.2	$^\circ\text{C}/\text{W}$

**GATE CHARACTERISTICS** (maximum values)

$P_{GM} = 40 \text{ W}$  ( $t_p = 10 \mu\text{s}$ )       $I_{GM} = 4 \text{ A}$  ( $t_p = 10 \mu\text{s}$ )  
 $P_{G(AV)} = 1 \text{ W}$        $V_{GM} = 16 \text{ V}$  ( $t_p = 10 \mu\text{s}$ )

**ELECTRICAL CHARACTERISTICS**

Symbol	Test Conditions			Quadrants	Min.	Typ.	Max.	Unit
$I_{GT}$	$T_j = 25 \text{ }^\circ\text{C}$ Pulse Duration > 20 $\mu\text{s}$	$V_D = 12 \text{ V}$	$R_L = 33 \text{ } \Omega$	I-II-III			50	mA
				IV			100	
$V_{GT}$	$T_j = 25 \text{ }^\circ\text{C}$ Pulse Duration > 20 $\mu\text{s}$	$V_D = 12 \text{ V}$	$R_L = 33 \text{ } \Omega$	I-II-III-IV			1.5	V
$V_{GD}$	$T_j = 110 \text{ }^\circ\text{C}$	$V_D = V_{DRM}$	$R_L = 3.3 \text{ k}\Omega$	I-II-III-IV	0.2			V
$I_{H^*}$	$T_j = 25 \text{ }^\circ\text{C}$	$I_T = 100 \text{ mA}$	Gate Open				50	mA
$I_L$	$T_j = 25 \text{ }^\circ\text{C}$ Pulse Duration > 20 $\mu\text{s}$	$V_D = 12 \text{ V}$	$I_G = 200 \text{ mA}$	I-III-IV		50		mA
				II		100		
$V_{TM}^*$	$T_j = 25 \text{ }^\circ\text{C}$	$I_{TM} = 11 \text{ A}$	$t_p = 10 \text{ ms}$				1.75	V
$I_{DRM}^*$	$V_{DRM}$ Specified	$T_j = 25 \text{ }^\circ\text{C}$					0.01	mA
		$T_j = 110 \text{ }^\circ\text{C}$					0.5	
$dv/dt^*$	$T_j = 110 \text{ }^\circ\text{C}$	Gate Open			250	500		V/ $\mu\text{s}$
$(dv/dt)_c^*$	$T_c = 75 \text{ }^\circ\text{C}$	$V_D = V_{DRM}$	$I_T = 11 \text{ A}$		10			V/ $\mu\text{s}$
		$(di/dt)_c = 3.5 \text{ A/ms}$						
$t_{gt}$	$T_j = 25 \text{ }^\circ\text{C}$	$V_D = V_{DRM}$	$I_T = 11 \text{ A}$	I-II-III-IV		2		$\mu\text{s}$
		$I_G = 80 \text{ mA}$	$di_G/dt = 1 \text{ A}/\mu\text{s}$					

\* For either polarity of electrode  $A_2$  voltage with reference to electrode  $A_1$ .

**PACKAGE MECHANICAL DATA**

TO 220 AB Plastic

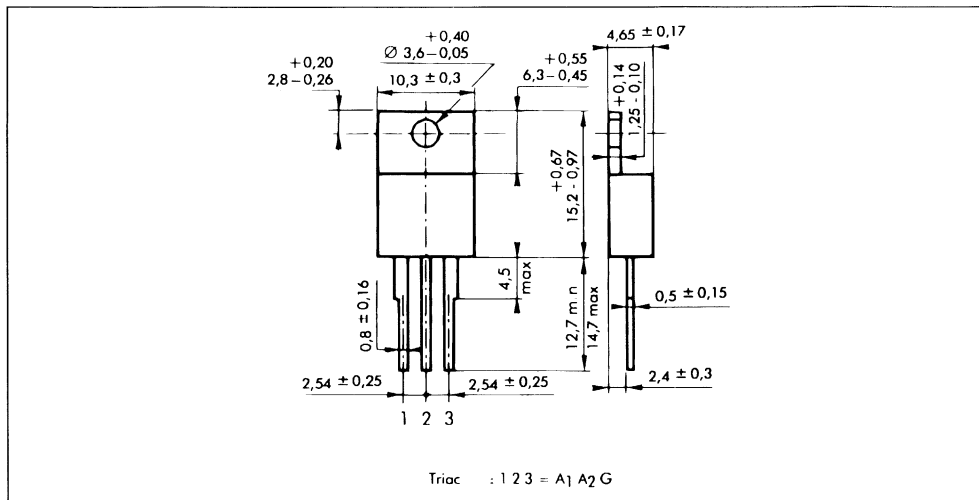

Cooling method : by conduction (method C)

Marking : type number

Weight : 2 g.

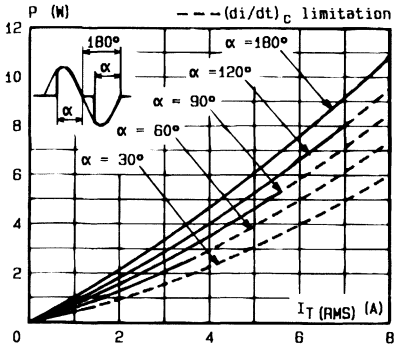

Fig. 1 - Maximum mean power dissipation versus RMS on-state current ( $F = 60$  Hz).

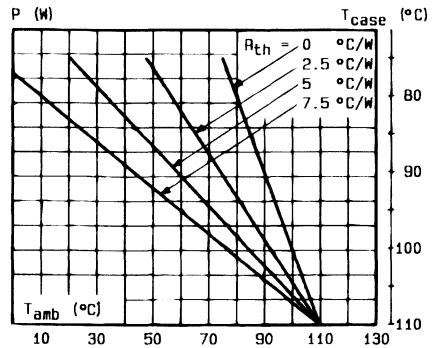

Fig. 2 - Correlation between maximum mean power dissipation and maximum allowable temperatures ( $T_{amb}$  and  $T_{case}$ ) for different thermal resistances heatsink + contact.

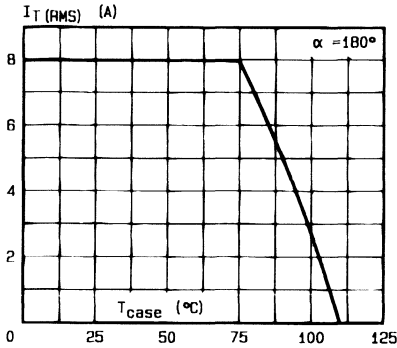

Fig. 3 - RMS on-state current versus case temperature.

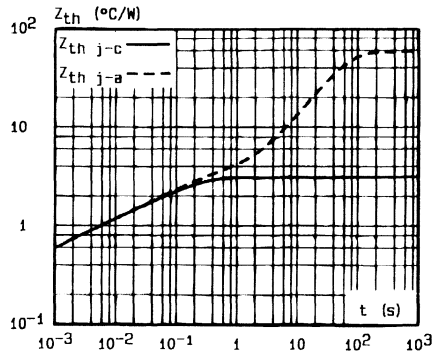

Fig. 4 - Thermal transient impedance junction to case and junction to ambient versus pulse duration.

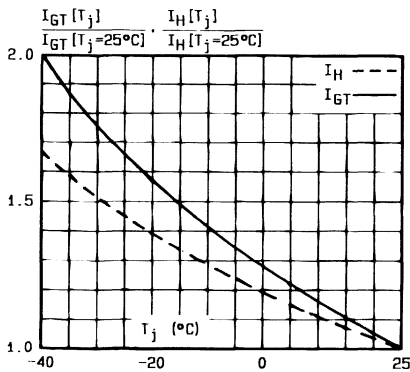

Fig. 5 - Relative variation of gate trigger current and holding current versus junction temperature.

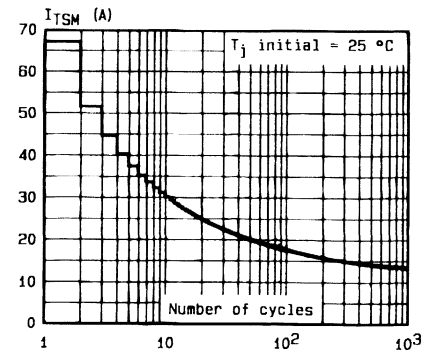

Fig. 6 - Non repetitive surge peak on-state current versus number of cycles.

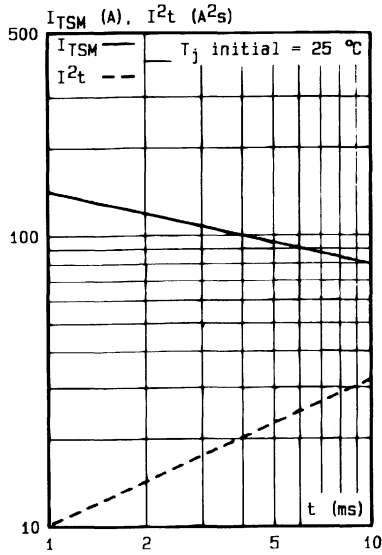

Fig.7 - Non repetitive surge peak on-state current for a sinusoidal pulse with width :  $t \leq 10$  ms, and corresponding value of  $I^2t$ .

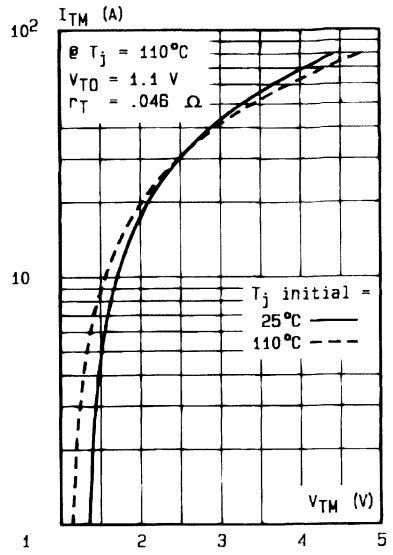
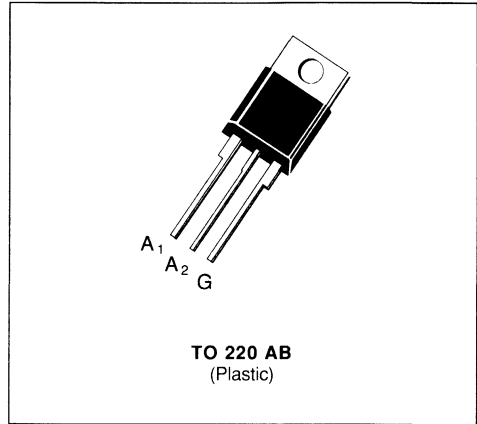

Fig.8 - On-state characteristics (maximum values).

**TRIACS**

- GLASS PASSIVATED CHIP
- EXCELLENT  $(dv/dt)_c > 5 \text{ V}/\mu\text{s}$
- I<sub>GT</sub> SPECIFIED IN FOUR QUADRANTS
- AVAILABLE IN INSULATED VERSION → BTA SERIES (INSULATING VOLTAGE 2500 V<sub>RMS</sub>) OR IN UNINSULATED VERSION → BTB SERIES
- UL RECOGNIZED FOR BTA SERIES (E81734)

**DESCRIPTION**

New range suited for applications such as phase control and static switching.

**ABSOLUTE RATINGS** (limiting values)

Symbol	Parameter	Value	Unit
$I_{T(RMS)}$	RMS on-state Current (360° conduction angle) $T_C = 75 \text{ }^\circ\text{C}$	8	A
$I_{TSM}$	Non Repetitive Surge Peak on-state Current ( $T_j$ initial = 25 °C - Half sine wave)	$t = 8.3 \text{ ms}$	84
		$t = 10 \text{ ms}$	80
$I^2t$	$I^2t$ Value for Fusing $t = 10 \text{ ms}$	32	A <sup>2</sup> s
di/dt	Critical Rate of Rise of on-state Current (1)	Repetitive $F = 50 \text{ Hz}$	10
		Non Repetitive	50
$T_{stg}$ $T_j$	Storage and Operating Junction Temperature Range	- 40 to 150	°C
		- 40 to 110	°C

Symbol	Parameter	BTA/BTB 08-					Unit
		200C	400C	600C	700C	800C	
$V_{DRM}$	Repetitive Peak off-state Voltage (2)	200	400	600	700	800	V

- (1)  $I_G = 500 \text{ mA}$      $di_G/dt = 1 \text{ A}/\mu\text{s}$   
 (2)  $T_j = 110 \text{ }^\circ\text{C}$ .

**THERMAL RESISTANCES**

Symbol	Parameter	Value	Unit
$R_{th(j-a)}$	Junction to Ambient	60	°C/W
$R_{th(j-c)} \text{ DC}$	Junction to Case for DC	4.3	°C/W
$R_{th(j-c)} \text{ AC}$	Junction to Case for 360° Conduction Angle ( $F = 50 \text{ Hz}$ )	3.2	°C/W

**GATE CHARACTERISTICS** (maximum values)

$P_{GM} = 40 \text{ W}$  ( $t_p = 10 \mu\text{s}$ )       $I_{GM} = 4 \text{ A}$  ( $t_p = 10 \mu\text{s}$ )  
 $P_{G(AV)} = 1 \text{ W}$        $V_{GM} = 16 \text{ V}$  ( $t_p = 10 \mu\text{s}$ )

**ELECTRICAL CHARACTERISTICS**

Symbol	Test Conditions			Quadrants	Min.	Typ.	Max.	Unit
$I_{GT}$	$T_j = 25 \text{ }^\circ\text{C}$ Pulse Duration > 20 $\mu\text{s}$	$V_D = 12 \text{ V}$	$R_L = 33 \text{ } \Omega$	I-II-III			25	mA
				IV			50	
$V_{GT}$	$T_j = 25 \text{ }^\circ\text{C}$ Pulse Duration > 20 $\mu\text{s}$	$V_D = 12 \text{ V}$	$R_L = 33 \text{ } \Omega$	I-II-III-IV			1.5	V
$V_{GD}$	$T_j = 110 \text{ }^\circ\text{C}$	$V_D = V_{DRM}$	$R_L = 3.3 \text{ k}\Omega$	I-II-III-IV	0.2			V
$I_{H^*}$	$T_j = 25 \text{ }^\circ\text{C}$	$I_T = 100 \text{ mA}$	Gate Open				25	mA
$I_L$	$T_j = 25 \text{ }^\circ\text{C}$ Pulse Duration > 20 $\mu\text{s}$	$V_D = 12 \text{ V}$	$I_G = 100 \text{ mA}$	I-III-IV		50		mA
				II		100		
$V_{TM}^*$	$T_j = 25 \text{ }^\circ\text{C}$	$I_{TM} = 11 \text{ A}$	$t_p = 10 \text{ ms}$				1.75	V
$I_{DRM}^*$	$V_{DRM}$ Specified						0.01	mA
							0.5	
$dv/dt^*$	$T_j = 110 \text{ }^\circ\text{C}$	Gate Open			100	200		V/ $\mu\text{s}$
$(dv/dt)_c^*$	$T_C = 75 \text{ }^\circ\text{C}$ $(di/dt)_c = 3.5 \text{ A/ms}$	$V_D = V_{DRM}$	$I_T = 11 \text{ A}$		5			V/ $\mu\text{s}$
$t_{gt}$	$T_j = 25 \text{ }^\circ\text{C}$	$V_D = V_{DRM}$ $di_G/dt = 1 \text{ A}/\mu\text{s}$	$I_T = 11 \text{ A}$	I-II-III-IV		2		$\mu\text{s}$

\* For either polarity of electrode  $A_2$  voltage with reference to electrode  $A_1$ .

**PACKAGE MECHANICAL DATA**

TO 220 AB Plastic

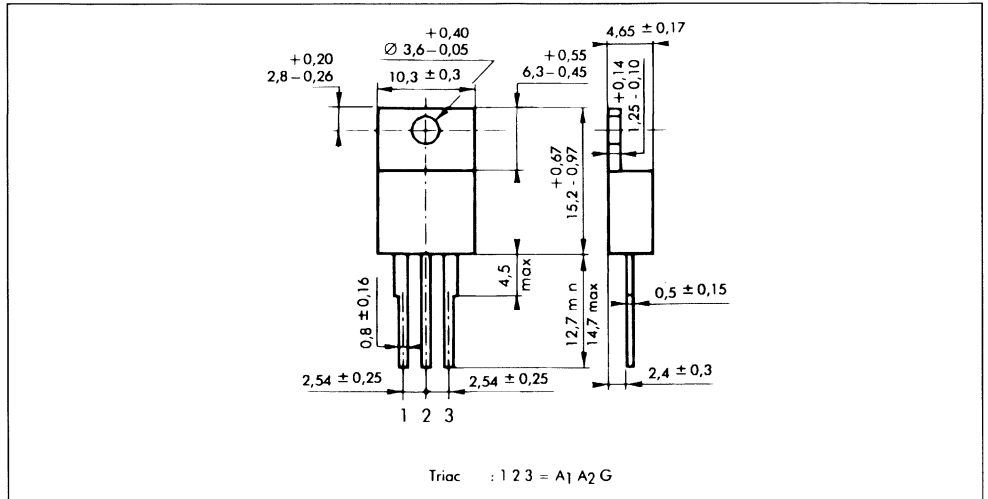

Cooling method : by conduction (method C)  
 Marking : type number  
 Weight : 2 g.

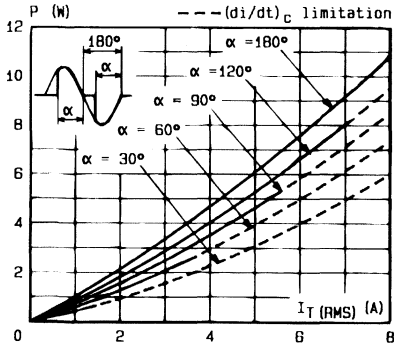

Fig. 1 - Maximum mean power dissipation versus RMS on-state current ( $F = 60 \text{ Hz}$ ).

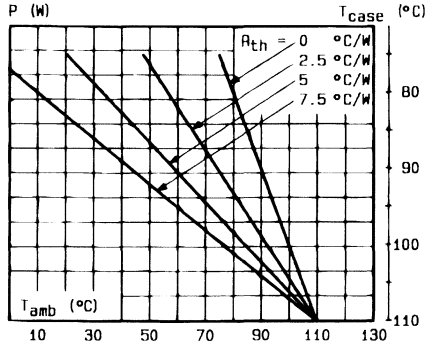

Fig. 2 - Correlation between maximum mean power dissipation and maximum allowable temperatures ( $T_{amb}$  and  $T_{case}$ ) for different thermal resistances heatsink + contact.

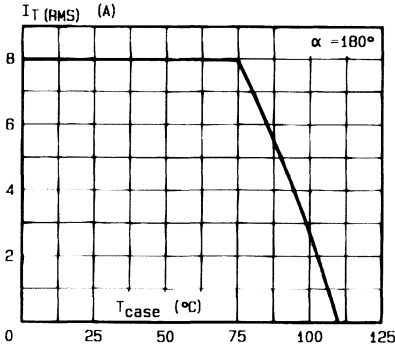

Fig. 3 - RMS on-state current versus case temperature.

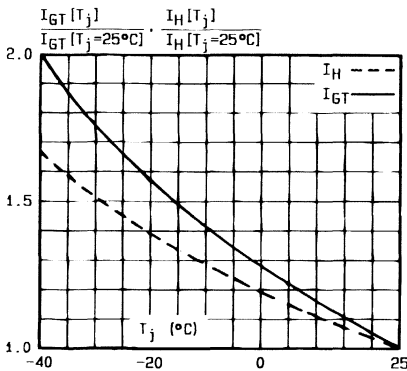

Fig. 5 - Relative variation of gate trigger current and holding current versus junction temperature.

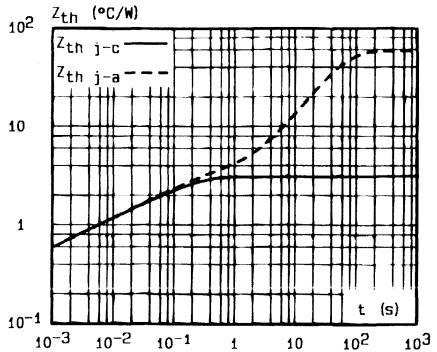

Fig. 4 - Thermal transient impedance junction to case and junction to ambient versus pulse duration.

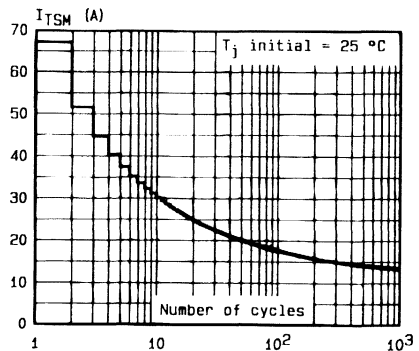

Fig. 6 - Non repetitive surge peak on-state current versus number of cycles.

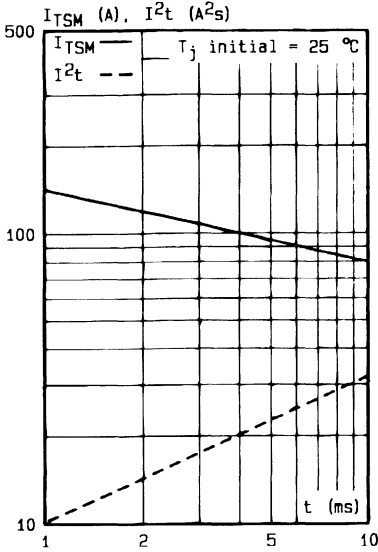

Fig.7 - Non repetitive surge peak on-state current for a sinusoidal pulse with width :  $t \leq 10$  ms, and corresponding value of  $I^2t$ .

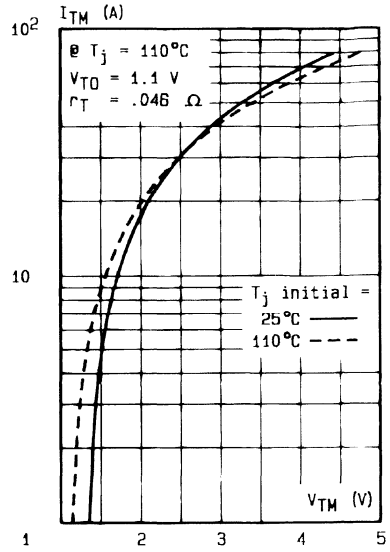
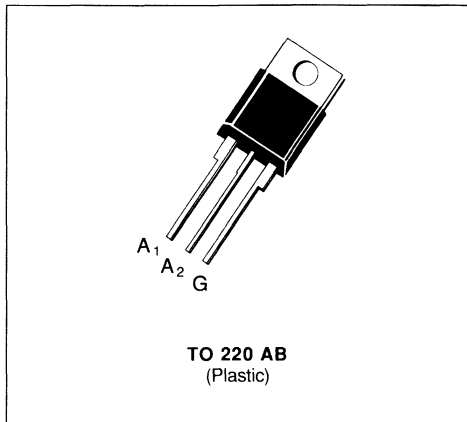

Fig.8 - On-state characteristics (maximum values)



**SENSITIVE GATE TRIACS**

- GLASS PASSIVATED CHIP
- $I_{GT}$  SPECIFIED IN FOUR QUADRANTS
- AVAILABLE IN INSULATED VERSION → BTA SERIES (INSULATING VOLTAGE 2500  $V_{RMS}$ ) OR IN UNINSULATED VERSION → BTB SERIES
- UL RECOGNIZED FOR BTA SERIES (E81734)

**DESCRIPTION**

New range suited for applications such as phase control and static switching.

**ABSOLUTE RATINGS** (limiting values)

Symbol	Parameter	Value	Unit
$I_{T(RMS)}$	RMS on-state Current (360° conduction angle) $T_C = 75^\circ C$	8	A
$I_{TSM}$	Non Repetitive Surge Peak on-state Current ( $T_j$ initial = 25 °C - Half sine wave)	$t = 8.3$ ms	84
		$t = 10$ ms	80
$I^2t$	$I^2t$ Value for Fusing	$t = 10$ ms	$A^2s$
di/dt	Critical Rate of Rise of on-state Current (1)	Repetitive $F = 50$ Hz	10
		Non Repetitive	50
$T_{stg}$ $T_j$	Storage and Operating Junction Temperature Range	- 40 to 150 - 40 to 110	°C °C

Symbol	Parameter	BTA/BTB 08-					Unit
		200S	400S	600S	700S	800S	
$V_{DRM}$	Repetitive Peak off-state Voltage (2)	200	400	600	700	800	V

(1)  $I_G = 100$  mA    di/dt = 1 A/ $\mu$ s

(2)  $T_j = 110^\circ C$ .

**THERMAL RESISTANCES**

Symbol	Parameter	Value	Unit
$R_{th(j-a)}$	Junction to Ambient	60	°C/W
$R_{th(j-c)} DC$	Junction to Case for DC	5.1	°C/W
$R_{th(j-c)} AC$	Junction to Case for 360° Conduction Angle ( $F = 50$ Hz)	3.8	°C/W

**GATE CHARACTERISTICS** (maximum values)

$P_{GM} = 40 \text{ W}$  ( $t_p = 10 \mu\text{s}$ )       $I_{GM} = 4 \text{ A}$  ( $t_p = 10 \mu\text{s}$ )  
 $P_{G(AV)} = 1 \text{ W}$        $V_{GM} = 16 \text{ V}$  ( $t_p = 10 \mu\text{s}$ )

**ELECTRICAL CHARACTERISTICS**

Symbol	Test Conditions	Quadrants	Min.	Typ.	Max.	Unit
$I_{GT}$	$T_j = 25 \text{ }^\circ\text{C}$ $V_D = 12 \text{ V}$ $R_L = 33 \text{ } \Omega$ Pulse Duration > 20 $\mu\text{s}$	I-II-III-IV			10	mA
$V_{GT}$	$T_j = 25 \text{ }^\circ\text{C}$ $V_D = 12 \text{ V}$ $R_L = 33 \text{ } \Omega$ Pulse Duration > 20 $\mu\text{s}$	I-II-III-IV			1.5	V
$V_{GD}$	$T_j = 110 \text{ }^\circ\text{C}$ $V_D = V_{DRM}$ $R_L = 3.3 \text{ k}\Omega$	I-II-III-IV	0.2			V
$I_{H^*}$	$T_j = 25 \text{ }^\circ\text{C}$ $I_T = 100 \text{ mA}$ Gate Open				25	mA
$I_L$	$T_j = 25 \text{ }^\circ\text{C}$ $V_D = 12 \text{ V}$ $I_G = 20 \text{ mA}$ Pulse Duration > 20 $\mu\text{s}$	I-III-IV		25		mA
		II		50		
$V_{TM^*}$	$T_j = 25 \text{ }^\circ\text{C}$ $I_{TM} = 11 \text{ A}$ $t_p = 10 \text{ ms}$				1.75	V
$I_{DRM^*}$	$V_{DRM}$ Specified	$T_j = 25 \text{ }^\circ\text{C}$			0.01	mA
		$T_j = 110 \text{ }^\circ\text{C}$			0.5	
$dv/dt^*$	$T_j = 110 \text{ }^\circ\text{C}$ Gate Open Linear Slope up to $V_D = 67\% V_{DRM}$		10			V/ $\mu\text{s}$
$(dv/dt)_c^*$	$T_c = 75 \text{ }^\circ\text{C}$ $V_D = V_{DRM}$ $I_T = 11 \text{ A}$ $(di/dt)_c = 3.5 \text{ A/ms}$			5		V/ $\mu\text{s}$
$t_{gt}$	$T_j = 25 \text{ }^\circ\text{C}$ $V_D = V_{DRM}$ $I_T = 11 \text{ A}$ $I_G = 40 \text{ mA}$ $di_G/dt = 0.45 \text{ A}/\mu\text{s}$	I-II-III-IV		2		$\mu\text{s}$

\* For either polarity of electrode A<sub>2</sub> voltage with reference to electrode A<sub>1</sub>.

**PACKAGE MECHANICAL DATA**

TO 220 AB Plastic

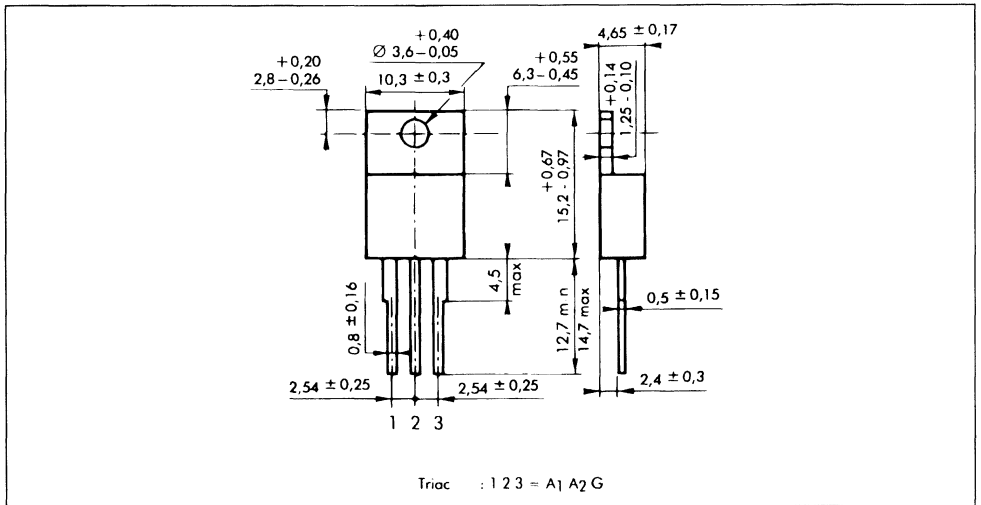

Cooling method : by conduction (method C)  
 Marking : type number  
 Weight : 2 g

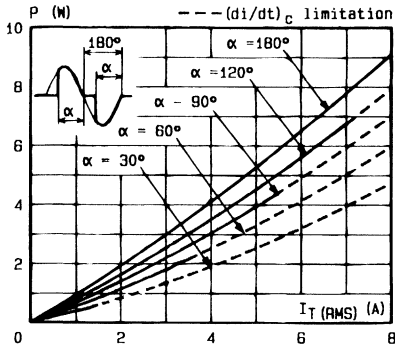

Fig. 1 - Maximum mean power dissipation versus RMS on-state current ( $F = 60 \text{ Hz}$ ).

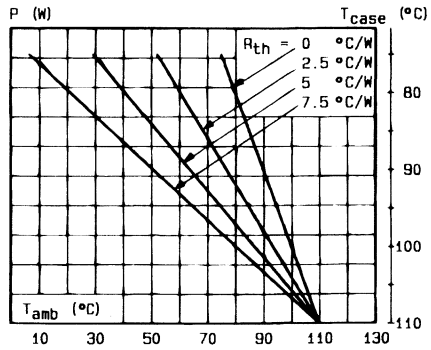

Fig. 2 - Correlation between maximum mean power dissipation and maximum allowable temperatures ( $T_{amb}$  and  $T_{case}$ ) for different thermal resistances heatsink + contact.

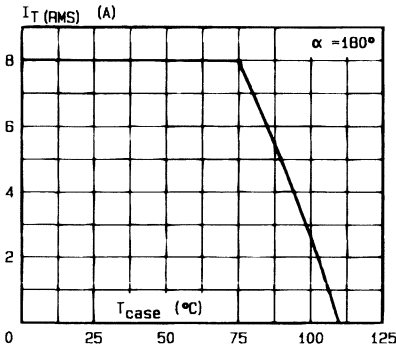

Fig. 3 - RMS on-state current versus case temperature.

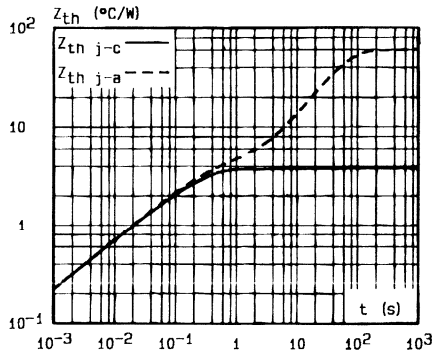

Fig. 4 - Thermal transient impedance junction to case and junction to ambient versus pulse duration.

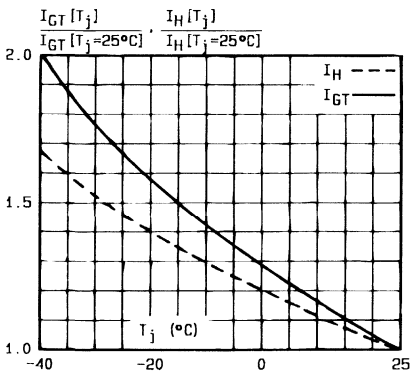

Fig. 5 - Relative variation of gate trigger current and holding current versus junction RMS temperature.

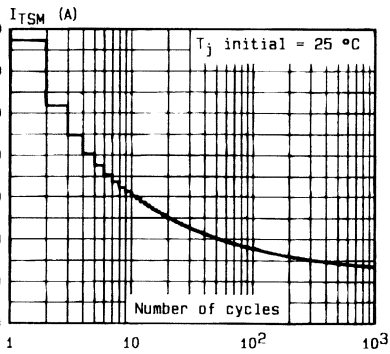

Fig. 6 - Non repetitive surge peak on-state current versus number of cycles.

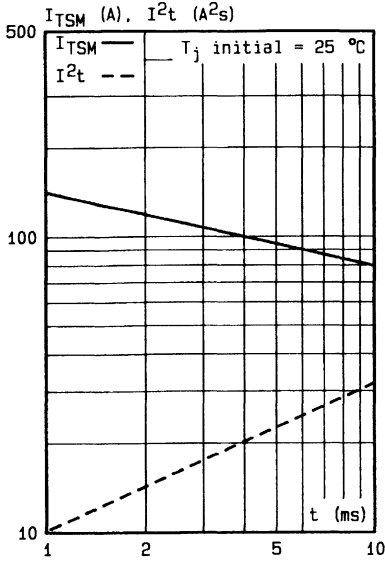

Fig.7 - Non repetitive surge peak on-state current for a sinusoidal pulse with width :  $t \leq 10$  ms, and corresponding value of  $I^2t$ .

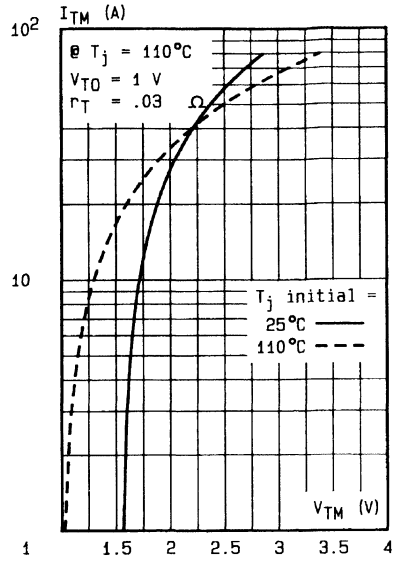

Fig.8 - On-state characteristics (maximum values).

**LOGIC LEVEL TRIACS**

- $I_{TRMS} = 8 \text{ A}$  at  $T_c = 80 \text{ }^\circ\text{C}$ .
- $V_{DRM} : 200 \text{ V}$  to  $800 \text{ V}$ .
- $I_{GT} = 10 \text{ mA}$  (QI-II-III).
- $(di/dt)_c = 4.5 \text{ A/ms}$  @  $(dv/dt)_c = 50 \text{ V}/\mu\text{s}$ .
- SUITED FOR LOW POWER TRIGGER CIRCUITS (INTEGRATED CIRCUITS AND MICROPROCESSORS).
- GLASS PASSIVATED CHIP.
- HIGH EFFICIENCY SWITCHING.
- AVAILABLE IN INSULATED VERSION → BTA SERIES (INSULATING VOLTAGE :  $2500 V_{RMS}$ ) OR IN UNINSULATED VERSION → BTB SERIES.
- UL RECOGNIZED FOR BTA SERIES (E81734).

**DESCRIPTION**

New range suited for applications such as phase control and static switching on inductive or resistive load.

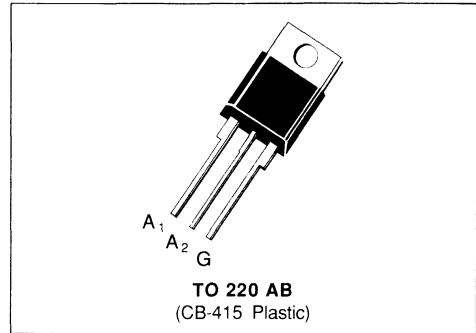
**ABSOLUTE RATINGS** (limiting values)

Symbol	Parameter	Value	Unit
$I_{TRMS}$	RMS on-state current (360 ° conduction angle)	$T_c = 80 \text{ }^\circ\text{C}$ 8	A
$I_{TSM}$	Non repetitive surge peak on-state current ( $T_j$ initial = $25 \text{ }^\circ\text{C}$ )	$t = 8.3 \text{ ms}$ 95	A
		$t = 10 \text{ ms}$ 85	
$I^2t$	$I^2t$ value	$t = 10 \text{ ms}$ 36	$\text{A}^2\text{s}$
$di/dt$	Critical rate of rise of on-state current (1)	Repetitive $F = 50 \text{ Hz}$ 20	A / $\mu\text{s}$
		Non Repetitive 100	
$T_{stg}$ $T_j$	Storage and operating junction temperature range	- 40, + 150 - 40, + 110	$^\circ\text{C}$ $^\circ\text{C}$

Symbol	Parameter	BTA/BTB 08-					Unit
		200 SW	400 SW	600 SW	700 SW	800 SW	
$V_{DRM}$	Repetitive peak off-state voltage (2)	$\pm 200$	$\pm 400$	$\pm 600$	$\pm 700$	$\pm 800$	V

(1) Gate supply :  $I_G = 100 \text{ mA}$  –  $di_G/dt = 1 \text{ A}/\mu\text{s}$ .

(2)  $T_j = 110 \text{ }^\circ\text{C}$ .

**THERMAL RESISTANCES**

Symbol	Parameter	Value	Unit
$R_{th(j-a)}$	Junction to ambient	60	°C/W
$R_{th(j-c) DC}$	Junction to case for DC	3.5	°C/W
$R_{th(j-c) AC}$	Junction to case for 360 ° conduction angle (F = 50 Hz)	2.6	°C/W

**GATE CHARACTERISTICS (maximum values)**
 $P_{GM} = 40 \text{ W (} t = 10 \mu\text{s)}$     $P_{G(AV)} = 1 \text{ W}$     $I_{GM} = 4 \text{ A (} t = 10 \mu\text{s)}$     $V_{GM} = 16 \text{ V (} t = 10 \mu\text{s)}$ .

**ELECTRICAL CHARACTERISTICS**

Symbol	Test Conditions	Quadrants	Min.	Typ.	Max.	Unit	
$I_{GT}$	$T_j = 25 \text{ °C}$ $V_D = 12 \text{ V}$ $R_L = 33 \text{ }\Omega$ Pulse duration > 20 $\mu\text{s}$	I-II-III			10	mA	
$V_{GT}$	$T_j = 25 \text{ °C}$ $V_D = 12 \text{ V}$ $R_L = 33 \text{ }\Omega$ Pulse duration > 20 $\mu\text{s}$	I-II-III			1.5	V	
$V_{GD}$	$T_j = 110 \text{ °C}$ $V_D = V_{DRM}$ $R_L = 3.3 \text{ k}\Omega$ Pulse duration > 20 $\mu\text{s}$	I-II-III	0.2			V	
$I_H^*$	$T_j = 25 \text{ °C}$ $I_T = 100 \text{ mA}$ Gate open $R_L = 140 \text{ }\Omega$				25	mA	
$I_L$	$T_j = 25 \text{ °C}$ $V_D = 12 \text{ V}$ $R_L = 33 \text{ }\Omega$ Pulse duration > 20 $\mu\text{s}$	I-III		25		mA	
		II		50			
$V_{TM}^*$	$T_j = 25 \text{ °C}$ $I_{TM} = 11 \text{ A}$ $t_p = 10 \text{ ms}$				1.75	V	
$I_{DRM}^*$	$T_j = 25 \text{ °C}$ $T_j = 110 \text{ °C}$	$V_{DRM}$ rated	Gate open			10	$\mu\text{A}$
						500	
$dv/dt^*$	$T_j = 110 \text{ °C}$ Gate open Linear slope up to 0.67 $V_{DRM}$		50			V/ $\mu\text{s}$	
$(di/dt)_c^*$	$T_j = 110 \text{ °C}$ $(dv/dt)_c = 0.1 \text{ V}/\mu\text{s}$		4.5	7		A/ms	
	$T_j = 110 \text{ °C}$ $(dv/dt)_c = 50 \text{ V}/\mu\text{s}$		3.5	4.5			
$t_{gt}$	$T_j = 25 \text{ °C}$ $dI_G/dt = 1 \text{ A}/\mu\text{s}$ $I_G = 50 \text{ mA}$ $I_T = 11 \text{ A}$ $V_D = V_{DRM}$	I-II-III		2		$\mu\text{s}$	

\* For either polarity of electrode A<sub>2</sub> voltage with reference to electrode A<sub>1</sub>.

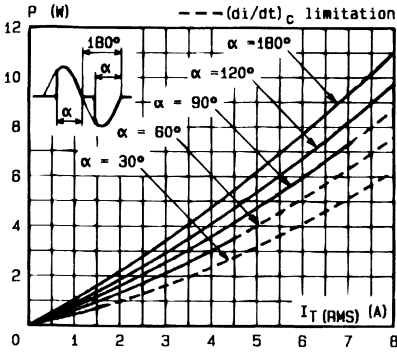

Fig. 1 - Maximum mean power dissipation versus RMS on-state current ( $f = 60$  Hz).

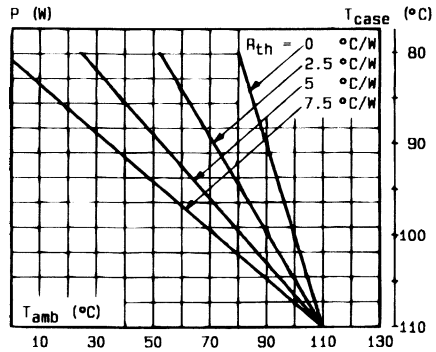

Fig. 2 - Correlation between maximum mean power dissipation and maximum allowable temperatures ( $T_{amb}$  and  $T_{case}$ ) for different thermal resistances heatsink + contact.

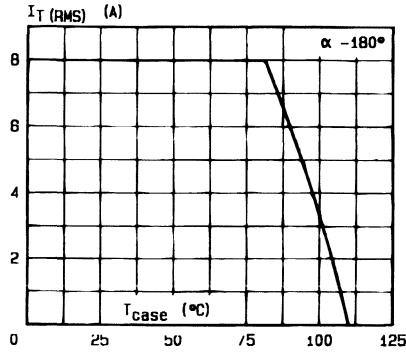

Fig. 3 - RMS on-state current versus case temperature.

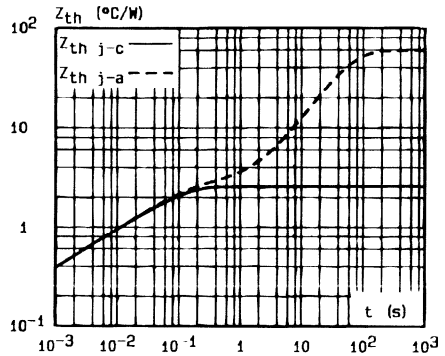

Fig. 4 - Thermal transient impedance junction to case and junction to ambient versus pulse duration.

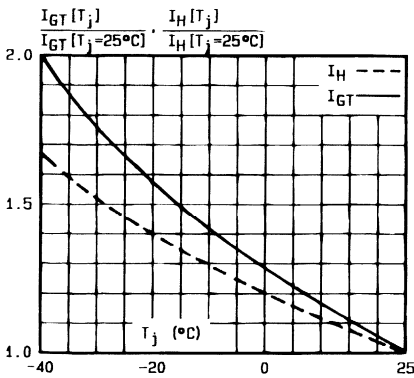

Fig. 5 - Relative variation of gate trigger current and holding current versus junction temperature.

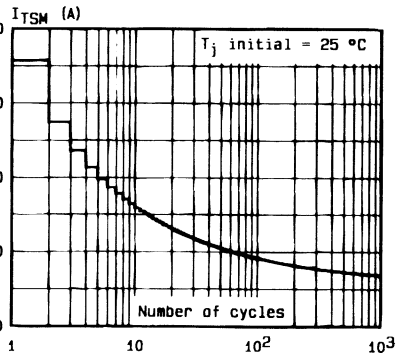

Fig. 6 - Non repetitive surge peak on-state current versus number of cycles.

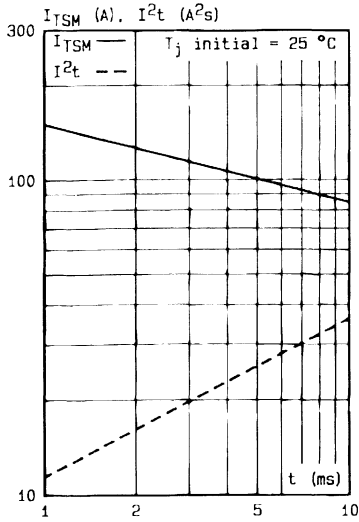

Fig.7 - Non repetitive surge peak on-state current variation for a sinusoidal pulse with width:  $t \leq 10$  ms, and corresponding value of  $I^2t$ .

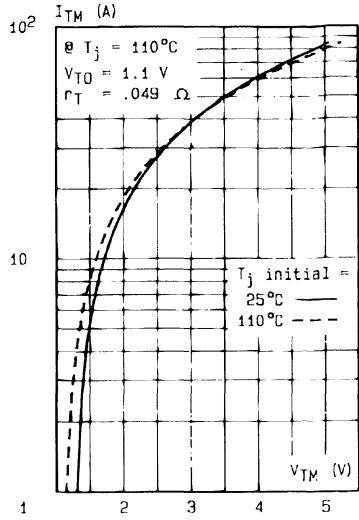

Fig.8 - On-state characteristics (maximum values).

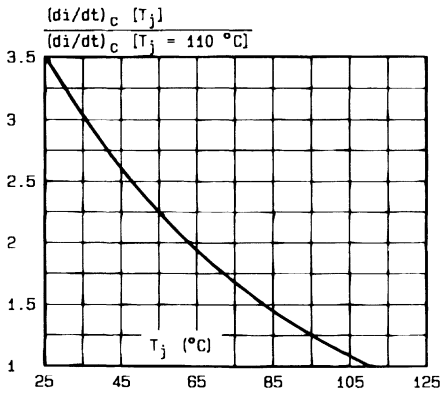

Fig.9 - Relative variation of  $(di/dt)_c$  versus junction temperature.

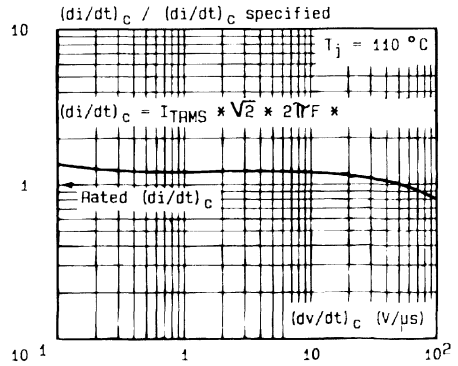
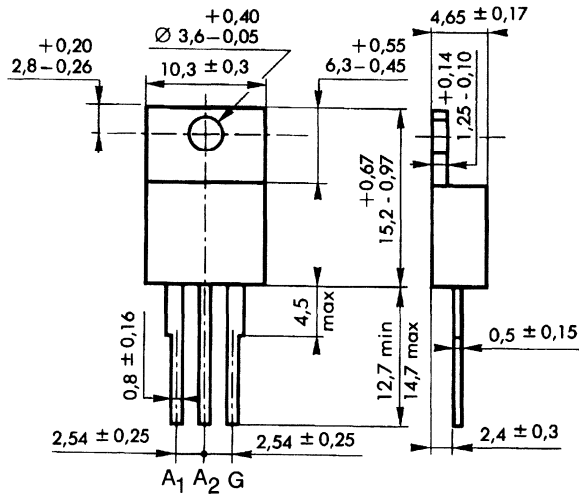

Fig.10 - Relative variation of  $(di/dt)_c$  versus  $(dv/dt)_c$  (inductive load) (typical values).



## PACKAGE MECHANICAL DATA

TO 220 AB (CB-415) Plastic



Cooling method : by conduction (method C)

Marking : type number

Weight : 2 g



**LOGIC LEVEL TRIACS**

- $I_{TRMS} = 8 \text{ A}$  at  $T_c = 80^\circ\text{C}$ .
- $V_{DRM} : 200 \text{ V}$  to  $800 \text{ V}$ .
- $I_{GT} = 5 \text{ mA}$  (QI-II-III).
- $(di/dt)_c = 3.5 \text{ A/ms}$  @  $(dv/dt)_c = 20 \text{ V}/\mu\text{s}$ .
- SUITED FOR LOW POWER TRIGGER CIRCUITS (INTEGRATED CIRCUITS AND MICROPROCESSORS).
- GLASS PASSIVATED CHIP.
- HIGH EFFICIENCY SWITCHING.
- AVAILABLE IN INSULATED VERSION → BTA SERIES (INSULATING VOLTAGE :  $2500 V_{RMS}$ ) OR IN UNINSULATED VERSION → BTB SERIES.
- UL RECOGNIZED FOR BTA SERIES (E81734).

**DESCRIPTION**

New range suited for applications such as phase control and static switching on inductive or resistive load.

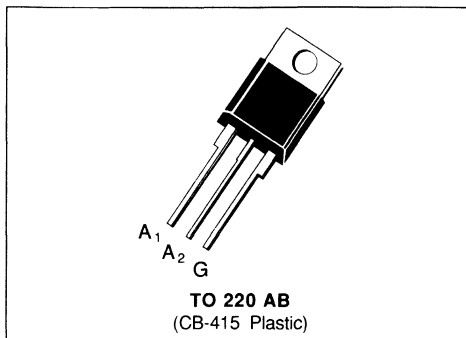
**ABSOLUTE RATINGS** (limiting values)

Symbol	Parameter	Value	Unit
$I_{TRMS}$	RMS on-state current (360° conduction angle)	$T_c = 80^\circ\text{C}$ 8	A
$I_{TSM}$	Non repetitive surge peak on-state current ( $T_j$ initial = $25^\circ\text{C}$ )	$t = 8.3 \text{ ms}$	95
		$t = 10 \text{ ms}$	85
$I^2 t$	$I^2 t$ value	$t = 10 \text{ ms}$	36
di/dt	Critical rate of rise of on-state current (1)	Repetitive $F = 50 \text{ Hz}$	20
		Non Repetitive	100
$T_{stg}$ $T_j$	Storage and operating junction temperature range	- 40, + 150 - 40, + 110	$^\circ\text{C}$ $^\circ\text{C}$

Symbol	Parameter	BTA/BTB 08-					Unit
		200 TW	400 TW	600 TW	700 TW	800 TW	
$V_{DRM}$	Repetitive peak off-state voltage (2)	± 200	± 400	± 600	± 700	± 800	V

(1) Gate supply :  $I_G = 50 \text{ mA}$  –  $di_G/dt = 1 \text{ A}/\mu\text{s}$ .

(2)  $T_j = 110^\circ\text{C}$ .

**THERMAL RESISTANCES**

Symbol	Parameter	Value	Unit
$R_{th(j-a)}$	Junction to ambient	60	$^{\circ}\text{C/W}$
$R_{th(j-c)} \text{ DC}$	Junction to case for DC	3.5	$^{\circ}\text{C/W}$
$R_{th(j-c)} \text{ AC}$	Junction to case for $360^{\circ}$ conduction angle ( $F = 50 \text{ Hz}$ )	2.6	$^{\circ}\text{C/W}$

**GATE CHARACTERISTICS (maximum values)**

$P_{GM} = 40 \text{ W}$  ( $t = 10 \mu\text{s}$ )    $P_{G(AV)} = 1 \text{ W}$     $I_{GM} = 4 \text{ A}$  ( $t = 10 \mu\text{s}$ )    $V_{GM} = 16 \text{ V}$  ( $t = 10 \mu\text{s}$ ).

**ELECTRICAL CHARACTERISTICS**

Symbol	Test Conditions		Quadrants	Min.	Typ.	Max.	Unit
$I_{GT}$	$T_j = 25^{\circ}\text{C}$ Pulse duration $> 20 \mu\text{s}$	$V_D = 12 \text{ V}$ $R_L = 33 \Omega$	I-II-III			5	mA
$V_{GT}$	$T_j = 25^{\circ}\text{C}$ Pulse duration $> 20 \mu\text{s}$	$V_D = 12 \text{ V}$ $R_L = 33 \Omega$	I-II-III			1.5	V
$V_{GD}$	$T_j = 110^{\circ}\text{C}$ Pulse duration $> 20 \mu\text{s}$	$V_D = V_{DRM}$ $R_L = 3.3 \text{ k}\Omega$	I-II-III	0.2			V
$I_H^*$	$T_j = 25^{\circ}\text{C}$ Gate open	$I_T = 100 \text{ mA}$ $R_L = 140 \Omega$				15	mA
$I_L$	$T_j = 25^{\circ}\text{C}$ Pulse duration $> 20 \mu\text{s}$	$V_D = 12 \text{ V}$ $R_L = 33 \Omega$ $I_G = 25 \text{ mA}$	I-III		15		mA
			II		30		
$V_{TM}^*$	$T_j = 25^{\circ}\text{C}$	$I_{TM} = 11 \text{ A}$				1.75	V
$I_{DRM}^*$	$T_j = 25^{\circ}\text{C}$	$V_{DRM}$ rated Gate open				10	$\mu\text{A}$
	$T_j = 110^{\circ}\text{C}$					500	
$dv/dt^*$	$T_j = 110^{\circ}\text{C}$ Linear slope up to $0.67 V_{DRM}$	Gate open		20			$\text{V}/\mu\text{s}$
$(di/dt)_c^*$	$T_j = 110^{\circ}\text{C}$	$(dv/dt)_c = 0.1 \text{ V}/\mu\text{s}$		3.5	5		A/ms
	$T_j = 110^{\circ}\text{C}$	$(dv/dt)_c = 20 \text{ V}/\mu\text{s}$		1.8	3.5		
$t_{gt}$	$T_j = 25^{\circ}\text{C}$ $I_T = 11 \text{ A}$	$di_G/dt = 1 \text{ A}/\mu\text{s}$ $V_D = V_{DRM}$	$I_G = 25 \text{ mA}$ I-II-III			2	$\mu\text{s}$

\* For either polarity of electrode  $A_2$  voltage with reference to electrode  $A_1$ .

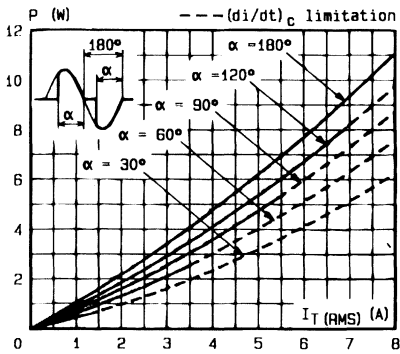

Fig.1 - Maximum mean power dissipation versus RMS on-state current ( $F = 60$  Hz).

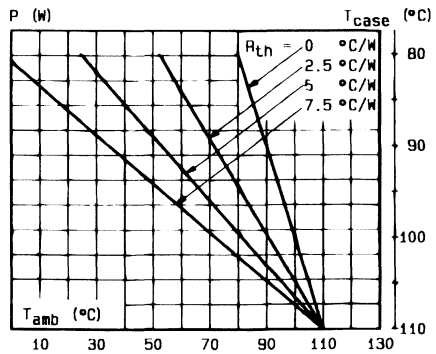

Fig.2 - Correlation between maximum mean power dissipation and maximum allowable temperatures ( $T_{amb}$  and  $T_{case}$ ) for different thermal resistances heatsink + contact.

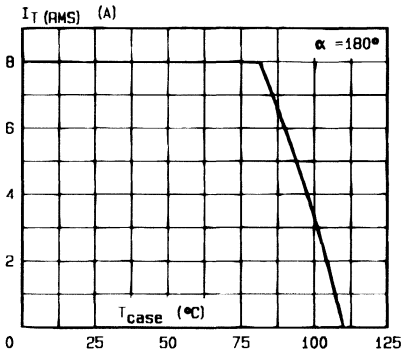

Fig.3 - RMS on-state current versus case temperature.

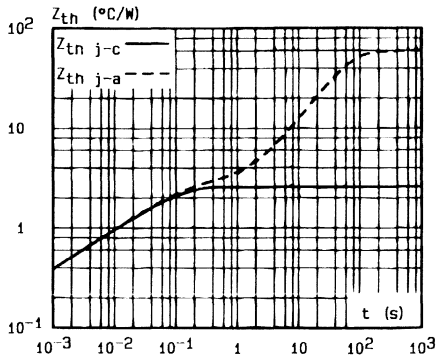

Fig.4 - Thermal transient impedance junction to case and junction to ambient versus pulse duration.

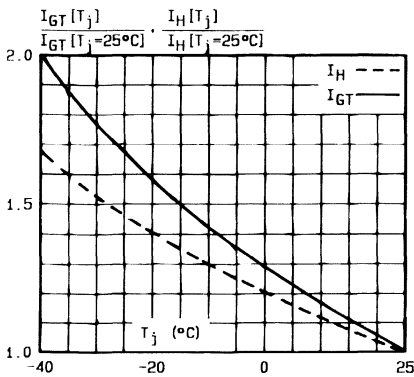

Fig.5 - Relative variation of gate trigger current and holding current versus junction temperature.

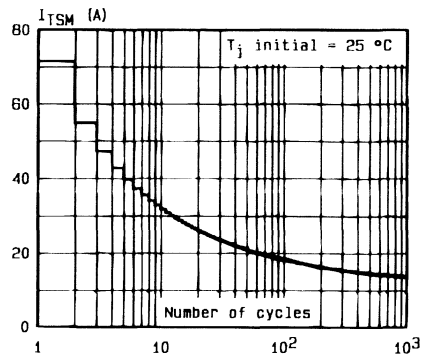

Fig.6 - Non repetitive surge peak on-state current versus number of cycles.

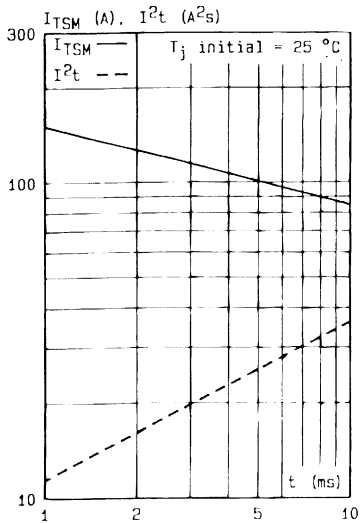

Fig.7 - Non repetitive surge peak on-state current for a sinusoidal pulse with width :  $t \leq 10$  ms, and corresponding value of  $I^2t$ .

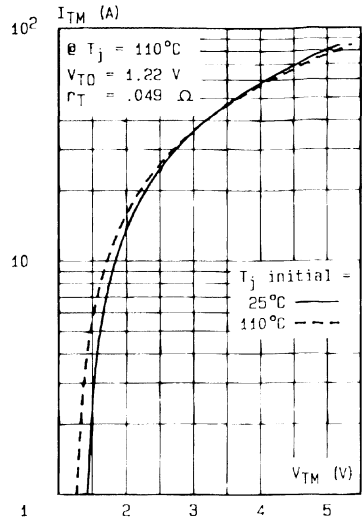

Fig.8 - On state characteristics (maximum values).

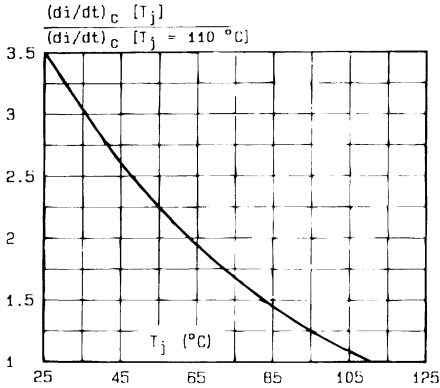

Fig.9 - Relative variation of  $(di/dt)_C$  versus junction temperature.

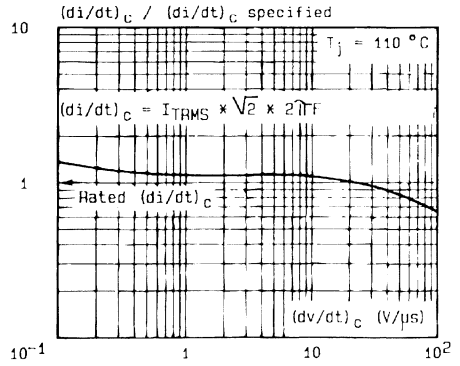
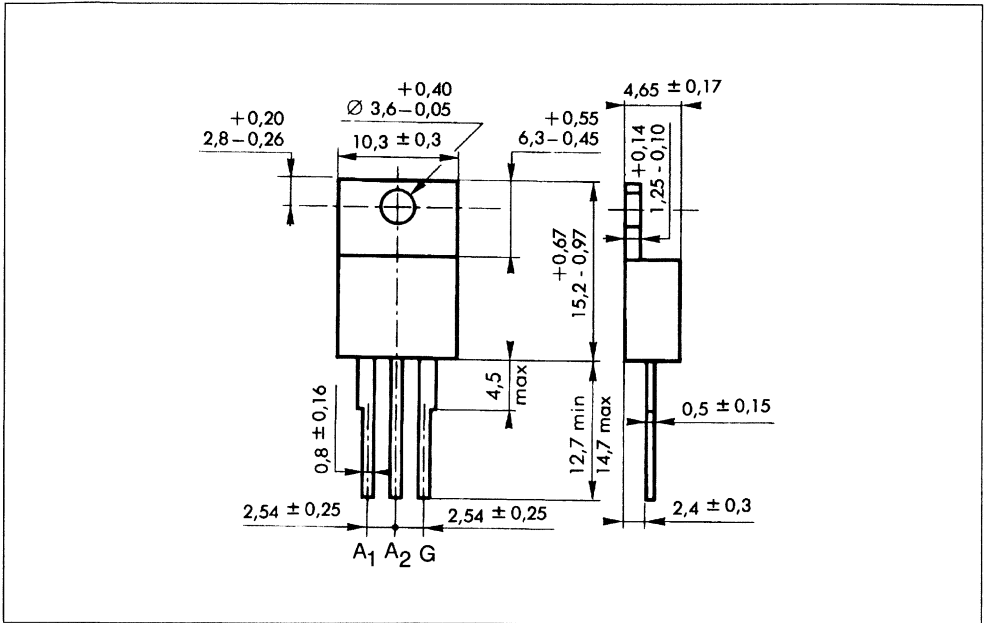

Fig.10 - Relative variation of  $(di/dt)_C$  versus  $(dv/dt)_C$  (inductive load) (typical values).

## PACKAGE MECHANICAL DATA

TO 220 AB (CB-415) Plastic



Cooling method : by conduction (method C)

Marking : type number

Weight : 2 g





**TRIACS**

- GLASS PASSIVATED CHIP
- EXCELLENT  $(dv/dt)_c > 10 \text{ V}/\mu\text{s}$
- $I_{GT}$  SPECIFIED IN FOUR QUADRANTS
- AVAILABLE IN INSULATED VERSION →  
 BTA SERIES (INSULATING VOLTAGE  
 2500  $V_{RMS}$ ) OR IN UNINSULATED VERSION  
 → BTB SERIES
- UL RECOGNIZED FOR BTA SERIES (E81734)

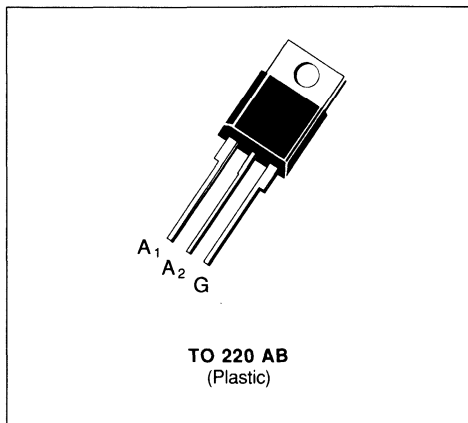
**DESCRIPTION**

New range suited for applications such as phase control and static switching.

**ABSOLUTE RATINGS** (limiting values)

Symbol	Parameter	Value	Unit
$I_{T(RMS)}$	RMS on-state Current (360° conduction angle)	$T_C = 75 \text{ }^\circ\text{C}$ 10	A
$I_{TSM}$	Non Repetitive Surge Peak on-state Current ( $T_j$ initial = 25 °C - Half sine wave)	$t = 8.3 \text{ ms}$	100
		$t = 10 \text{ ms}$	100
$I^2t$	$I^2t$ Value for Fusing	$t = 10 \text{ ms}$ 50	A <sup>2</sup> s
di/dt	Critical Rate of Rise of on-state Current (1)	Repetitive $F = 50 \text{ Hz}$	10
		Non Repetitive	50
$T_{stg}$ $T_j$	Storage and Operating Junction Temperature Range	- 40 to 150	°C
		- 40 to 110	°C

Symbol	Parameter	BTA/BTB 10-					Unit
		200B	400B	600B	700B	800B	
$V_{DRM}$	Repetitive Peak off-state Voltage (2)	200	400	600	700	800	V

(1)  $I_G = 1 \text{ A}$   $di_G/dt = 1 \text{ A}/\mu\text{s}$

(2)  $T_j = 110 \text{ }^\circ\text{C}$ .

**THERMAL RESISTANCES**

Symbol	Parameter	Value	Unit
$R_{th(j-a)}$	Junction to Ambient	60	°C/W
$R_{th(j-c)} \text{ DC}$	Junction to Case for DC	3.9	°C/W
$R_{th(j-c)} \text{ AC}$	Junction to Case for 360 ° Conduction Angle ( $F = 50 \text{ Hz}$ )	2.9	°C/W

**GATE CHARACTERISTICS** (maximum values)

 $P_{GM} = 40 \text{ W}$  ( $t_p = 10 \mu\text{s}$ )

 $I_{GM} = 4 \text{ A}$  ( $t_p = 10 \mu\text{s}$ )

 $P_{G(AV)} = 1 \text{ W}$ 
 $V_{GM} = 16 \text{ V}$  ( $t_p = 10 \mu\text{s}$ )

**ELECTRICAL CHARACTERISTICS**

Symbol	Test Conditions	Quadrants	Min.	Typ.	Max.	Unit
$I_{GT}$	$T_j = 25 \text{ }^\circ\text{C}$ $V_D = 12 \text{ V}$ $R_L = 33 \text{ } \Omega$ Pulse Duration > 20 $\mu\text{s}$	I-II-III			50	mA
		IV			100	
$V_{GT}$	$T_j = 25 \text{ }^\circ\text{C}$ $V_D = 12 \text{ V}$ $R_L = 33 \text{ } \Omega$ Pulse Duration > 20 $\mu\text{s}$	I-II-III-IV			1.5	V
$V_{GD}$	$T_j = 110 \text{ }^\circ\text{C}$ $V_D = V_{DRM}$ $R_L = 3.3 \text{ k}\Omega$	I-II-III-IV	0.2			V
$I_H^*$	$T_j = 25 \text{ }^\circ\text{C}$ $I_T = 100 \text{ mA}$ Gate Open				50	mA
$I_L$	$T_j = 25 \text{ }^\circ\text{C}$ $V_D = 12 \text{ V}$ $I_G = 200 \text{ mA}$ Pulse Duration > 20 $\mu\text{s}$	I-III-IV		50		mA
		II		100		
$V_{TM}^*$	$T_j = 25 \text{ }^\circ\text{C}$ $I_{TM} = 14 \text{ A}$ $t_p = 10 \text{ ms}$				1.5	V
$I_{DRM}^*$	$V_{DRM}$ Specified $T_j = 25 \text{ }^\circ\text{C}$ $T_j = 110 \text{ }^\circ\text{C}$				0.01	mA
					0.5	
$dv/dt^*$	$T_j = 110 \text{ }^\circ\text{C}$ Gate Open Linear Slope up to $V_D = 67\% V_{DRM}$		250	500		V/ $\mu\text{s}$
$(dv/dt)_c^*$	$T_C = 75 \text{ }^\circ\text{C}$ $V_D = V_{DRM}$ $I_T = 14 \text{ A}$ $(di/dt)_c = 4.4 \text{ A/ms}$		10			V/ $\mu\text{s}$
$t_{gt}$	$T_j = 25 \text{ }^\circ\text{C}$ $V_D = V_{DRM}$ $I_G = 80 \text{ mA}$ $di_G/dt = 1 \text{ A}/\mu\text{s}$	I-II-III-IV		2		$\mu\text{s}$

\* For either polarity of electrode  $A_2$  voltage with reference to electrode  $A_1$ .

**PACKAGE MECHANICAL DATA**

TO 220 AB Plastic

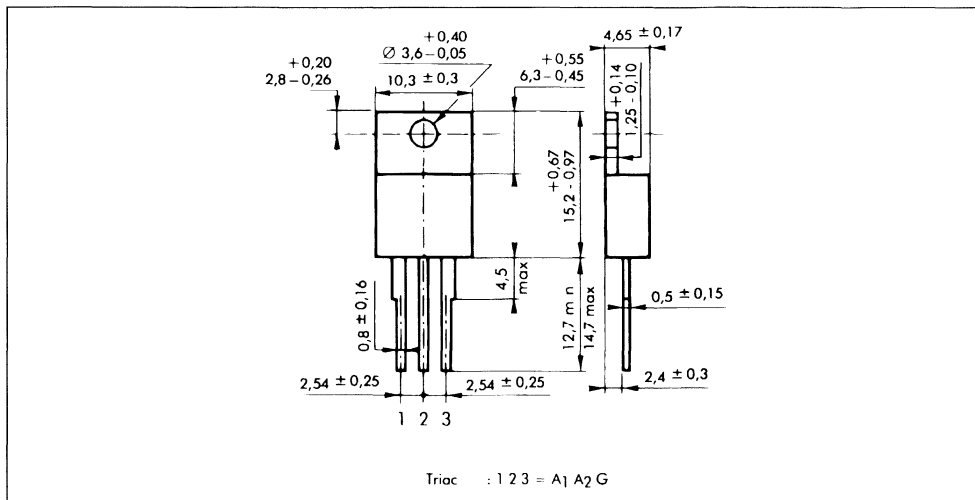

Cooling method : by conduction (method C)

Marking : type number

Weight : 2 g.

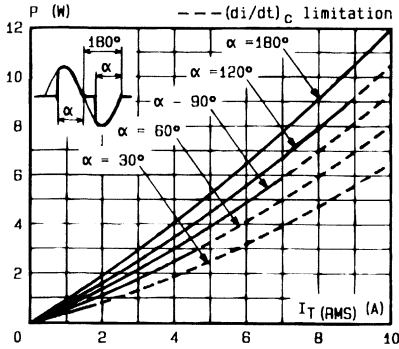

Fig. 1 - Maximum mean power dissipation versus RMS on-state current ( $F = 60 \text{ Hz}$ ).

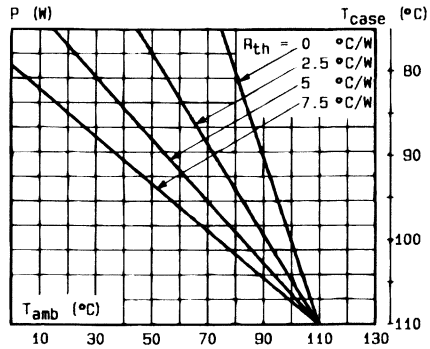

Fig. 2 - Correlation between maximum mean power dissipation and maximum allowable temperatures ( $T_{amb}$  and  $T_{case}$ ) for different thermal resistances heatsink + contact.

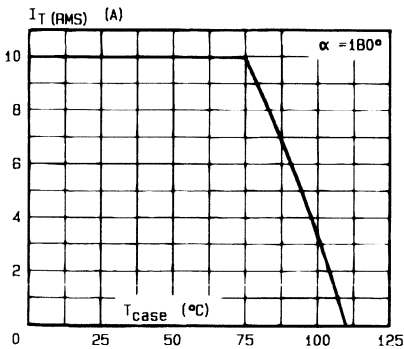

Fig. 3 - RMS on-state current versus case temperature.

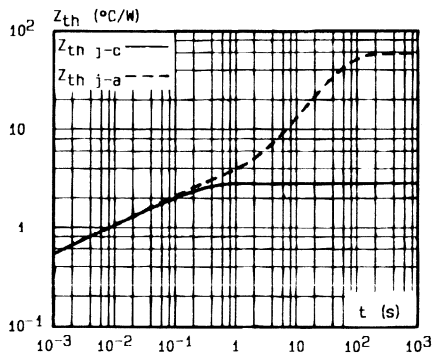

Fig. 4 - Thermal transient impedance junction to case and junction to ambient versus pulse duration.

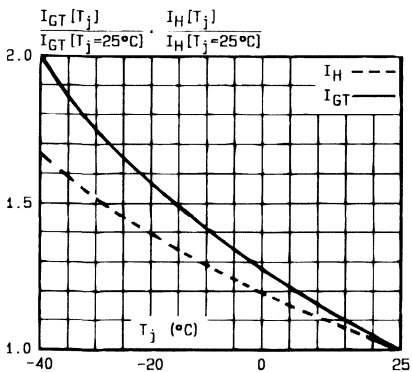

Fig. 5 - Relative variation of gate trigger current and holding current versus junction temperature.

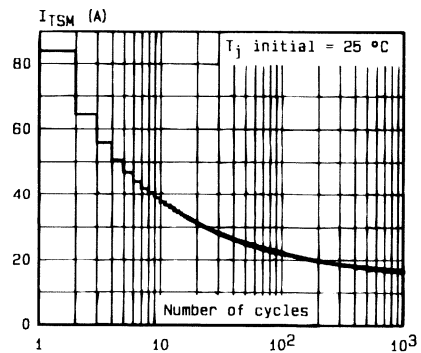

Fig. 6 - Non repetitive surge peak on-state current versus number of cycles.

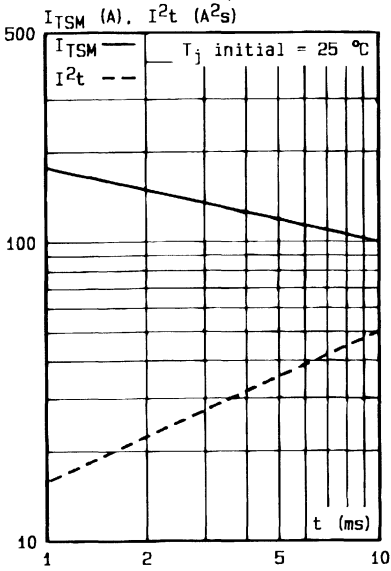

Fig.7 - Non repetitive surge peak on-state current for a sinusoidal pulse with width :  $t \leq 10$  ms, and corresponding value of  $I^2t$ .

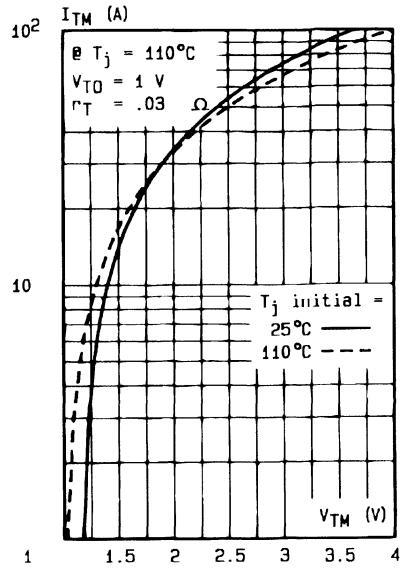
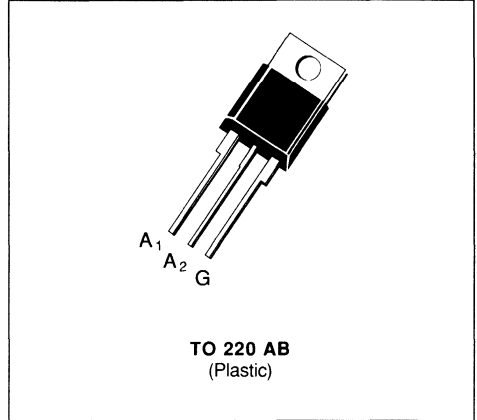

Fig.8 - On-state characteristics (maximum values).

## TRIACS

- GLASS PASSIVATED CHIP
- EXCELLENT  $(dv/dt)_c > 5 \text{ V}/\mu\text{s}$
- $I_{GT}$  SPECIFIED IN FOUR QUADRANTS
- AVAILABLE IN INSULATED VERSION → BTA SERIES (INSULATING VOLTAGE 2500  $V_{RMS}$ ) OR IN UNINSULATED VERSION → BTB SERIES
- UL RECOGNIZED FOR BTA SERIES (E81734)



### DESCRIPTION

New range suited for applications such as phase control and static switching.

### ABSOLUTE RATINGS (limiting values)

Symbol	Parameter	Value	Unit
$I_{T(RMS)}$	RMS on-state Current (360° conduction angle)	$T_C = 75 \text{ }^\circ\text{C}$ 10	A
$I_{TSM}$	Non Repetitive Surge Peak on-state Current ( $T_J$ initial = 25 °C - Half sine wave)	$t = 8.3 \text{ ms}$	105
		$t = 10 \text{ ms}$	100
$I^2t$	$I^2t$ Value for Fusing	$t = 10 \text{ ms}$ 50	$\text{A}^2\text{s}$
$di/dt$	Critical Rate of Rise of on-state Current (1)	Repetitive $F = 50 \text{ Hz}$	10
		Non Repetitive	50
$T_{stg}$ $T_J$	Storage and Operating Junction Temperature Range	- 40 to 150	$^\circ\text{C}$
		- 40 to 110	$^\circ\text{C}$

Symbol	Parameter	BTA/BTB 10-					Unit
		200C	400C	600C	700C	800C	
$V_{DRM}$	Repetitive Peak off-state Voltage (2)	200	400	600	700	800	V

- (1)  $I_G = 500 \text{ mA}$   $di_G/dt = 1 \text{ A}/\mu\text{s}$   
 (2)  $T_J = 110 \text{ }^\circ\text{C}$ .

### THERMAL RESISTANCES

Symbol	Parameter	Value	Unit
$R_{th(j-a)}$	Junction to Ambient	60	$^\circ\text{C}/\text{W}$
$R_{th(j-c)} \text{ DC}$	Junction to Case for DC	3.9	$^\circ\text{C}/\text{W}$
$R_{th(j-c)} \text{ AC}$	Junction to Case for 360° Conduction Angle ( $F = 50 \text{ Hz}$ )	2.9	$^\circ\text{C}/\text{W}$

**GATE CHARACTERISTICS** (maximum values)

$P_{GM} = 40 \text{ W}$  ( $t_p = 10 \mu\text{s}$ )       $I_{GM} = 4 \text{ A}$  ( $t_p = 10 \mu\text{s}$ )  
 $P_{G(AV)} = 1 \text{ W}$        $V_{GM} = 16 \text{ V}$  ( $t_p = 10 \mu\text{s}$ )

**ELECTRICAL CHARACTERISTICS**

Symbol	Test Conditions			Quadrants	Min.	Typ.	Max.	Unit
$I_{GT}$	$T_j = 25 \text{ }^\circ\text{C}$ Pulse Duration > 20 $\mu\text{s}$	$V_D = 12 \text{ V}$	$R_L = 33 \text{ } \Omega$	I-II-III			25	mA
				IV			50	
$V_{GT}$	$T_j = 25 \text{ }^\circ\text{C}$ Pulse Duration > 20 $\mu\text{s}$	$V_D = 12 \text{ V}$	$R_L = 33 \text{ } \Omega$	I-II-III-IV			1.5	V
$V_{GD}$	$T_j = 110 \text{ }^\circ\text{C}$	$V_D = V_{DRM}$	$R_L = 3.3 \text{ k}\Omega$	I-II-III-IV	0.2			V
$I_H^*$	$T_j = 25 \text{ }^\circ\text{C}$	$I_T = 100 \text{ mA}$	Gate Open				25	mA
$I_L$	$T_j = 25 \text{ }^\circ\text{C}$ Pulse Duration > 20 $\mu\text{s}$	$V_D = 12 \text{ V}$	$I_G = 100 \text{ mA}$	I-III-IV		50		mA
				II		100		
$V_{TM}^*$	$T_j = 25 \text{ }^\circ\text{C}$	$I_{TM} = 14 \text{ A}$	$t_p = 10 \text{ ms}$				1.5	V
$I_{DRM}^*$	$V_{DRM}$ Specified						0.01	mA
							0.5	
$dv/dt^*$	$T_j = 110 \text{ }^\circ\text{C}$	Gate Open	Linear Slope up to $V_D = 67\% V_{DRM}$		100	200		V/ $\mu\text{s}$
$(dv/dt)_c^*$	$T_C = 75 \text{ }^\circ\text{C}$	$V_D = V_{DRM}$	$I_T = 14 \text{ A}$		5			V/ $\mu\text{s}$
	$(di/dt)_c = 4.4 \text{ A/ms}$							
$t_{gt}$	$T_j = 25 \text{ }^\circ\text{C}$	$V_D = V_{DRM}$	$I_T = 14 \text{ A}$	I-II-III-IV		2		$\mu\text{s}$
	$I_G = 80 \text{ mA}$	$di_G/dt = 1 \text{ A}/\mu\text{s}$						

\* For either polarity of electrode A<sub>2</sub> voltage with reference to electrode A<sub>1</sub>.

**PACKAGE MECHANICAL DATA**

TO 220 AB Plastic

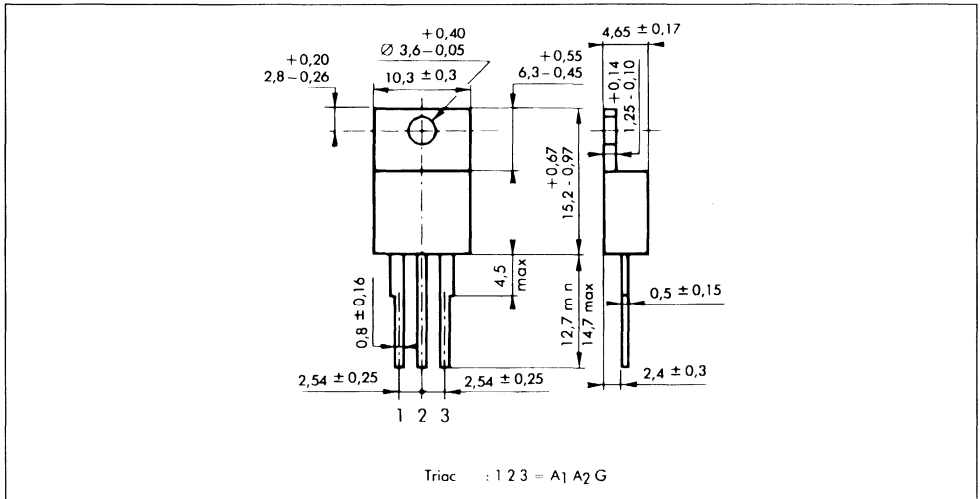

Cooling method : by conduction (method C)  
 Marking : type number  
 Weight : 2 g.

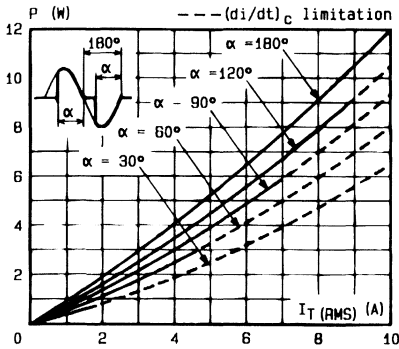

Fig. 1 - Maximum mean power dissipation versus RMS on-state current ( $F = 60$  Hz).

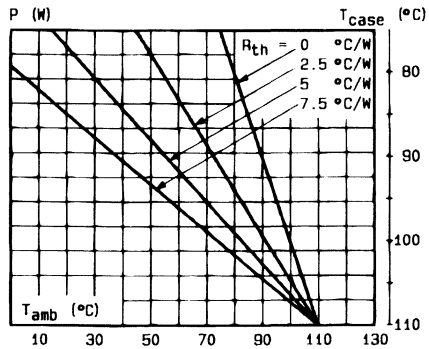

Fig. 2 - Correlation between maximum mean power dissipation and maximum allowable temperatures ( $T_{amb}$  and  $T_{case}$ ) for different thermal resistances heatsink + contact.

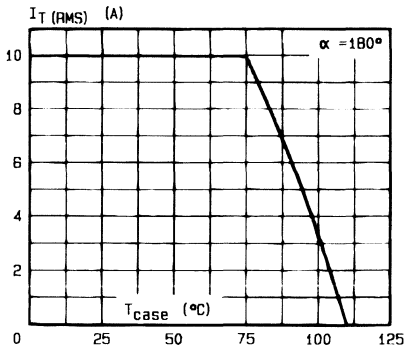

Fig. 3 - RMS on-state current versus case temperature.

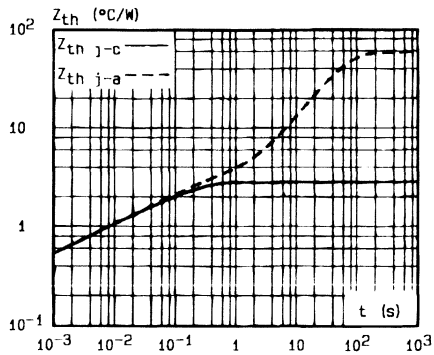

Fig. 4 - Thermal transient impedance junction to case and junction to ambient versus pulse duration.

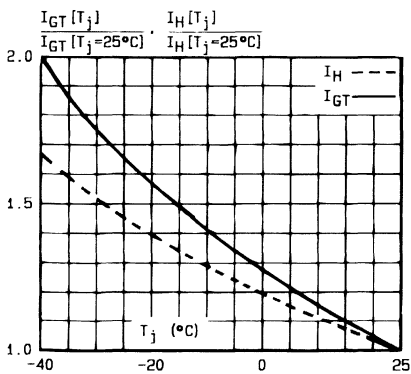

Fig. 5 - Relative variation of gate trigger current and holding current versus junction temperature.

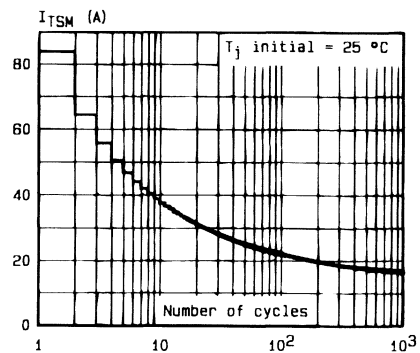

Fig. 6 - Non repetitive surge peak on-state current versus number of cycles.

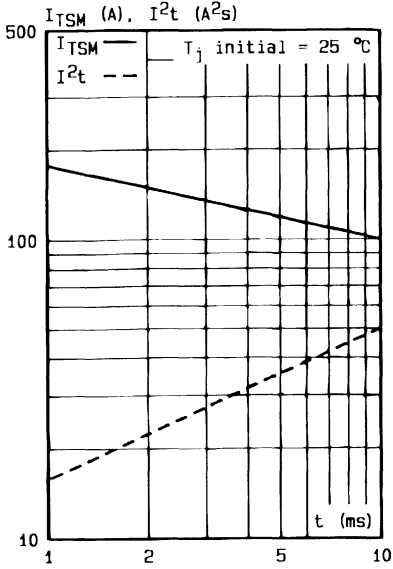

Fig.7 - Non repetitive surge peak on-state current for a sinusoidal pulse with width :  $t \leq 10$  ms, and corresponding value of  $I^2t$ .

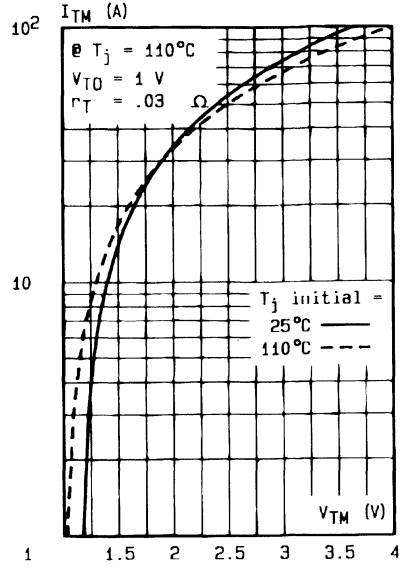
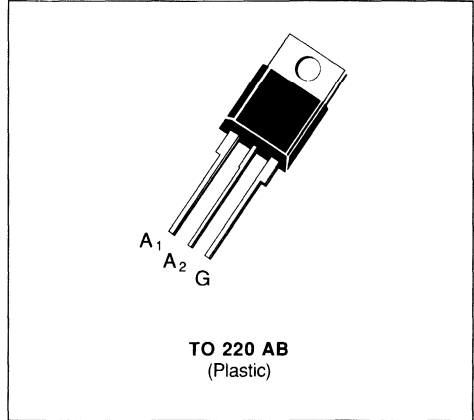

Fig.8 - On-state characteristics (maximum values).



**TRIACS**

- GLASS PASSIVATED CHIP
- EXCELLENT  $(dv/dt)_c > 10 \text{ V}/\mu\text{s}$
- $I_{GT}$  SPECIFIED IN FOUR QUADRANTS
- AVAILABLE IN INSULATED VERSION → BTA SERIES (INSULATING VOLTAGE 2500  $V_{RMS}$ ) OR IN UNINSULATED VERSION → BTB SERIES
- UL RECOGNIZED FOR BTA SERIES (E81734)

**DESCRIPTION**

New range suited for applications such as phase control and static switching.

**ABSOLUTE RATINGS** (limiting values)

Symbol	Parameter	Value	Unit
$I_{T(RMS)}$	RMS on state Current (360° conduction angle)	$T_C = 75^\circ\text{C}$ 12	A
$I_{TSM}$	Non Repetitive Surge Peak on-state Current ( $T_j$ initial = 25 °C - Half sine wave)	$t = 8.3 \text{ ms}$	125
		$t = 10 \text{ ms}$	120
$I^2t$	$I^2t$ Value for Fusing	$t = 10 \text{ ms}$ 72	$\text{A}^2\text{s}$
$di/dt$	Critical Rate of Rise of on-state Current (1)	Repetitive $F = 50 \text{ Hz}$	10
		Non Repetitive	50
$T_{stg}$ $T_j$	Storage and Operating Junction Temperature Range	- 40 to 150	°C
		- 40 to 110	°C

Symbol	Parameter	BTA/BTB 12-					Unit
		200B	400B	600B	700B	800B	
$V_{DRM}$	Repetitive Peak off-state Voltage (2)	200	400	600	700	800	V

- (1)  $I_G = 1 \text{ A}$   $di_G/dt = 1 \text{ A}/\mu\text{s}$   
 (2)  $T_j = 110^\circ\text{C}$ .

**THERMAL RESISTANCES**

Symbol	Parameter	Value	Unit
$R_{th(j-a)}$	Junction to Ambient	60	°C/W
$R_{th(j-c)} \text{ DC}$	Junction to Case for DC	3.3	°C/W
$R_{th(j-c)} \text{ AC}$	Junction to Case for 360° Conduction Angle ( $F = 50 \text{ Hz}$ )	2.5	°C/W

**GATE CHARACTERISTICS (maximum values)**

$P_{GM} = 40 \text{ W}$  ( $t_p = 10 \mu\text{s}$ )       $I_{GM} = 4 \text{ A}$  ( $t_p = 10 \mu\text{s}$ )  
 $P_{G(AV)} = 1 \text{ W}$        $V_{GM} = 16 \text{ V}$  ( $t_p = 10 \mu\text{s}$ )

**ELECTRICAL CHARACTERISTICS**

Symbol	Test Conditions			Quadrants	Min.	Typ.	Max.	Unit
$I_{GT}$	$T_j = 25 \text{ }^\circ\text{C}$ Pulse Duration > 20 $\mu\text{s}$	$V_D = 12 \text{ V}$	$R_L = 33 \text{ } \Omega$	I-II-III			50	mA
				IV			100	
$V_{GT}$	$T_j = 25 \text{ }^\circ\text{C}$ Pulse Duration > 20 $\mu\text{s}$	$V_D = 12 \text{ V}$	$R_L = 33 \text{ } \Omega$	I-II-III-IV			1.5	V
$V_{GD}$	$T_j = 110 \text{ }^\circ\text{C}$	$V_D = V_{DRM}$	$R_L = 3.3 \text{ k}\Omega$	I-II-III-IV	0.2			V
$I_H^*$	$T_j = 25 \text{ }^\circ\text{C}$	$I_T = 100 \text{ mA}$	Gate Open				50	mA
$I_L$	$T_j = 25 \text{ }^\circ\text{C}$ Pulse Duration > 20 $\mu\text{s}$	$V_D = 12 \text{ V}$	$I_G = 200 \text{ mA}$	I-III-IV		50		mA
				II		100		
$V_{TM}^*$	$T_j = 25 \text{ }^\circ\text{C}$	$I_{TM} = 17 \text{ A}$	$t_p = 10 \text{ ms}$				1.5	V
$I_{DRM}^*$	$V_{DRM}$ Specified	$T_j = 25 \text{ }^\circ\text{C}$					0.01	mA
		$T_j = 110 \text{ }^\circ\text{C}$					0.5	
$dv/dt^*$	$T_j = 110 \text{ }^\circ\text{C}$ Linear Slope up to $V_D = 67 \% V_{DRM}$	Gate Open			250	500		V/ $\mu\text{s}$
$(dv/dt)_c^*$	$T_c = 75 \text{ }^\circ\text{C}$ $(di/dt)_c = 5.3 \text{ A/ms}$	$V_D = V_{DRM}$	$I_T = 17 \text{ A}$		10			V/ $\mu\text{s}$
$t_{gt}$	$T_j = 25 \text{ }^\circ\text{C}$ $I_G = 80 \text{ mA}$	$V_D = V_{DRM}$ $di_G/dt = 1 \text{ A}/\mu\text{s}$	$I_T = 17 \text{ A}$	I-II-III-IV			2	$\mu\text{s}$

\* For either polarity of electrode  $A_2$  voltage with reference to electrode  $A_1$ .

**PACKAGE MECHANICAL DATA**

TO 220 AB Plastic

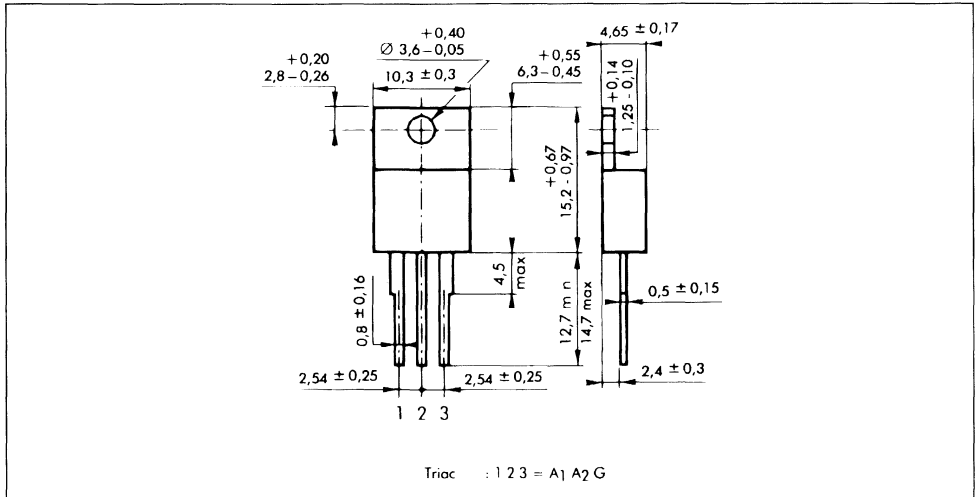

Cooling method : by conduction (method C)  
 Marking : type number  
 Weight : 2 g.

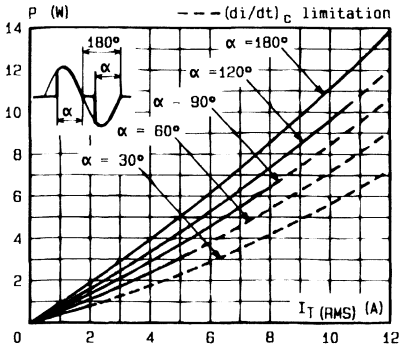

Fig.1 - Maximum mean power dissipation versus RMS on-state current ( $F = 60$  Hz).

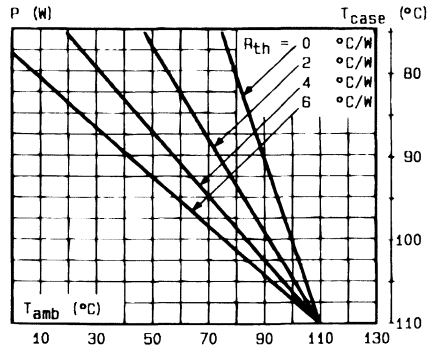

Fig.2 - Correlation between maximum mean power dissipation and maximum allowable temperatures ( $T_{amb}$  and  $T_{case}$ ) for different thermal resistances heatsink + contact.

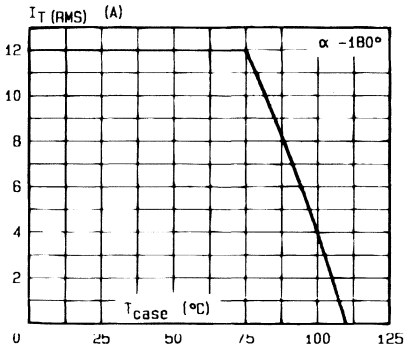

Fig.3 - RMS on-state current versus case temperature.

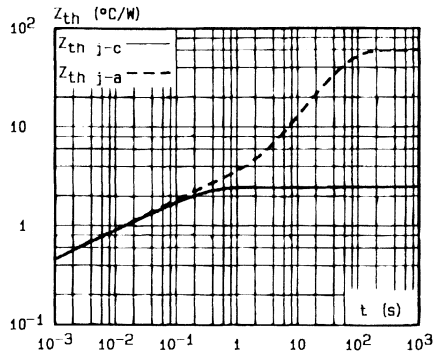

Fig.4 - Thermal transient impedance junction to case and junction to ambient versus pulse duration.

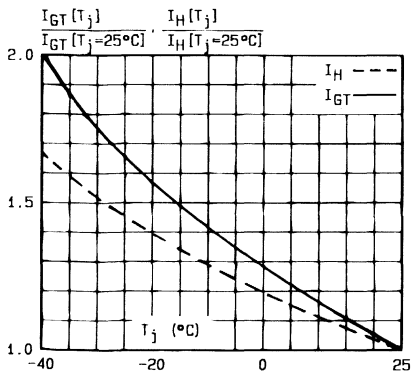

Fig.5 - Relative variation of gate trigger current and holding current versus junction temperature.

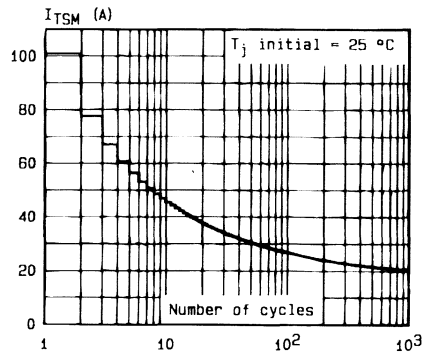

Fig.6 - Non repetitive surge peak on-state current versus number of cycles.

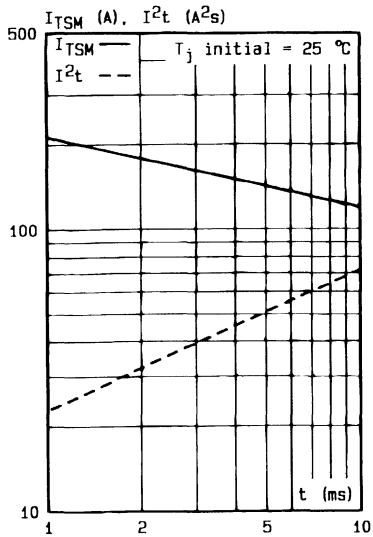

Fig.7 - Non repetitive surge peak on-state current for a sinusoidal pulse with width :  $t \leq 10$  ms. and corresponding value of  $I^2t$ .

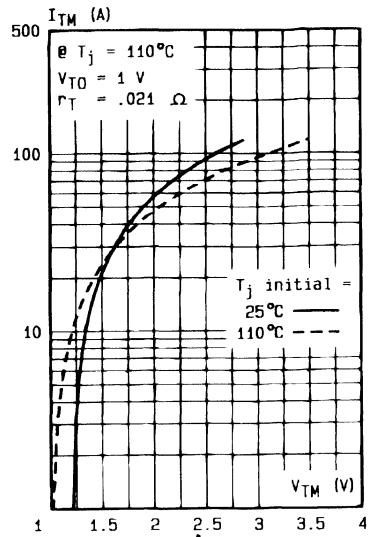
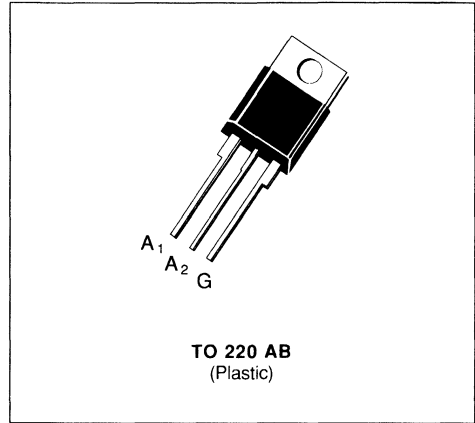

Fig.8 - On-state characteristics (maximum values).

**TRIACS**

- GLASS PASSIVATED CHIP
- EXCELLENT  $(dv/dt)_c > 5 \text{ V}/\mu\text{s}$
- $I_{GT}$  SPECIFIED IN FOUR QUADRANTS
- AVAILABLE IN INSULATED VERSION → BTA SERIES (INSULATING VOLTAGE 2500  $V_{RMS}$ ) OR IN UNINSULATED VERSION → BTB SERIES
- UL RECOGNIZED FOR BTA SERIES (E81734)

**DESCRIPTION**

New range suited for applications such as phase control and static switching.

**ABSOLUTE RATINGS** (limiting values)

Symbol	Parameter	Value	Unit
$I_{T(RMS)}$	RMS on-state Current (360° conduction angle)	$T_C = 75 \text{ }^\circ\text{C}$ 12	A
$I_{TSM}$	Non Repetitive Surge Peak on-state Current ( $T_J$ initial = 25 °C - Half sine wave)	$t = 8.3 \text{ ms}$	125
		$t = 10 \text{ ms}$	120
$I^2t$	$I^2t$ Value for Fusing	$t = 10 \text{ ms}$ 72	A <sup>2</sup> s
di/dt	Critical Rate of Rise of on-state Current (1)	Repetitive F = 50 Hz	10
		Non Repetitive	50
$T_{stg}$ $T_J$	Storage and Operating Junction Temperature Range	- 40 to 150	°C
		- 40 to 110	°C

Symbol	Parameter	BTA/BTB 12-					Unit
		200C	400C	600C	700C	800C	
$V_{DRM}$	Repetitive Peak off-state Voltage (2)	200	400	600	700	800	V

(1)  $I_G = 500 \text{ mA}$   $di_G/dt = 1 \text{ A}/\mu\text{s}$

(2)  $T_J = 110 \text{ }^\circ\text{C}$ .

**THERMAL RESISTANCES**

Symbol	Parameter	Value	Unit
$R_{th(j-a)}$	Junction to Ambient	60	°C/W
$R_{th(j-c)} \text{ DC}$	Junction to Case for DC	3.3	°C/W
$R_{th(j-c)} \text{ AC}$	Junction to Case for 360° Conduction Angle (F = 50 Hz)	2.5	°C/W

**GATE CHARACTERISTICS (maximum values)**

$P_{GM} = 40 \text{ W}$  ( $t_p = 10 \mu\text{s}$ )       $I_{GM} = 4 \text{ A}$  ( $t_p = 10 \mu\text{s}$ )  
 $P_{G(AV)} = 1 \text{ W}$        $V_{GM} = 16 \text{ V}$  ( $t_p = 10 \mu\text{s}$ )

**ELECTRICAL CHARACTERISTICS**

Symbol	Test Conditions	Quadrants	Min.	Typ.	Max.	Unit
$I_{GT}$	$T_j = 25 \text{ }^\circ\text{C}$ $V_D = 12 \text{ V}$ $R_L = 33 \text{ } \Omega$ Pulse Duration > 20 $\mu\text{s}$	I-II-III			25	mA
		IV			50	
$V_{GT}$	$T_j = 25 \text{ }^\circ\text{C}$ $V_D = 12 \text{ V}$ $R_L = 33 \text{ } \Omega$ Pulse Duration > 20 $\mu\text{s}$	I-II-III-IV			1.5	V
$V_{GD}$	$T_j = 110 \text{ }^\circ\text{C}$ $V_D = V_{DRM}$ $R_L = 3.3 \text{ k}\Omega$	I-II-III-IV	0.2			V
$I_{H^*}$	$T_j = 25 \text{ }^\circ\text{C}$ $I_T = 100 \text{ mA}$ Gate Open				25	mA
$I_L$	$T_j = 25 \text{ }^\circ\text{C}$ $V_D = 12 \text{ V}$ $I_G = 100 \text{ mA}$ Pulse Duration > 20 $\mu\text{s}$	I-III-IV		50		mA
		II		100		
$V_{TM}^*$	$T_j = 25 \text{ }^\circ\text{C}$ $I_{TM} = 17 \text{ A}$ $t_p = 10 \text{ ms}$				1.5	V
$I_{DRM}^*$	$V_{DRM}$ Specified				0.01	mA
					0.5	
$dv/dt^*$	$T_j = 110 \text{ }^\circ\text{C}$ Gate Open Linear Slope up to $V_D = 67\% V_{DRM}$		100	200		V/ $\mu\text{s}$
$(dv/dt)_c^*$	$T_C = 75 \text{ }^\circ\text{C}$ $V_D = V_{DRM}$ $I_T = 17 \text{ A}$ $(di/dt)_c = 5.3 \text{ A/ms}$		5			V/ $\mu\text{s}$
$t_{gt}$	$T_j = 25 \text{ }^\circ\text{C}$ $V_D = V_{DRM}$ $I_T = 17 \text{ A}$ $I_G = 80 \text{ mA}$ $di_G/dt = 1 \text{ A}/\mu\text{s}$	I-II-III-IV		2		$\mu\text{s}$

\* For either polarity of electrode  $A_2$  voltage with reference to electrode  $A_1$ .

**PACKAGE MECHANICAL DATA**

TO 220 AB Plastic

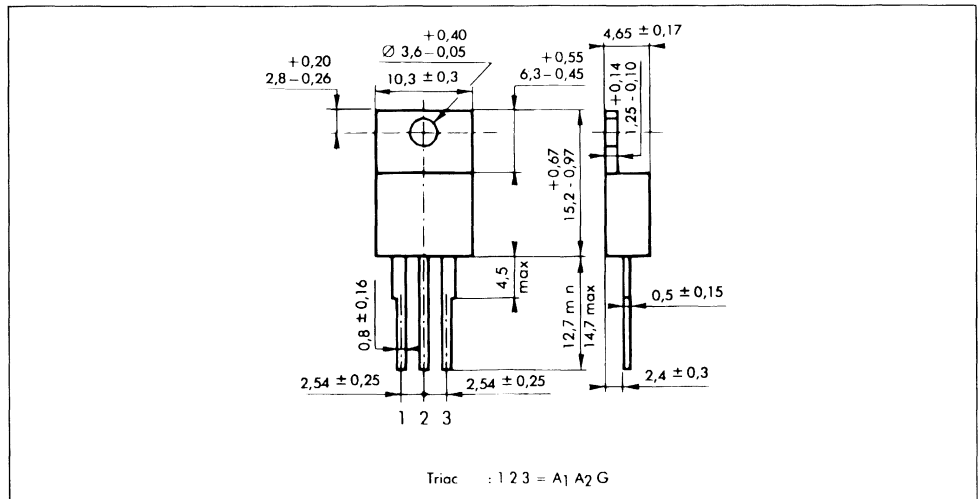

Cooling method : by conduction (method C)

Marking : type number

Weight : 2 g.

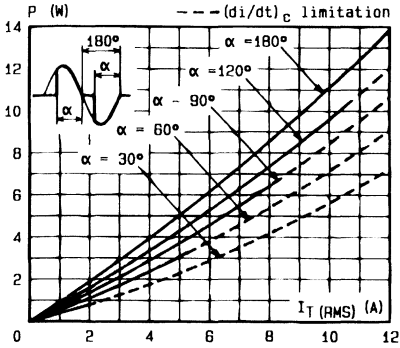

Fig. 1 - Maximum mean power dissipation versus RMS on-state current ( $f = 60$  Hz).

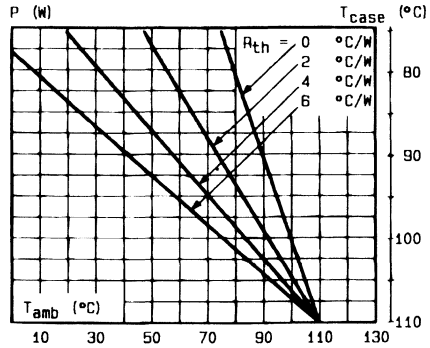

Fig. 2 - Correlation between maximum mean power dissipation and maximum allowable temperatures ( $T_{amb}$  and  $T_{case}$ ) for different thermal resistances heatsink + contact.

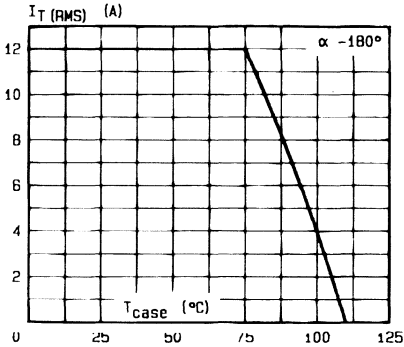

Fig. 3 - RMS on-state current versus case temperature.

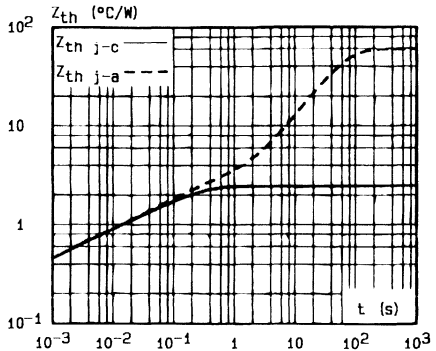

Fig. 4 - Thermal transient impedance to case and junction to ambient versus pulse duration.

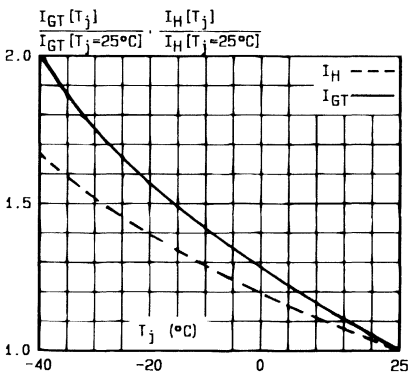

Fig. 5 - Relative variation of gate trigger current and holding current versus junction temperature.

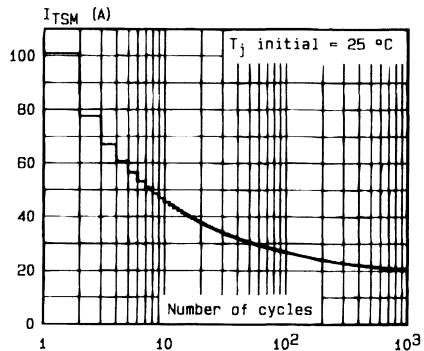

Fig 6 - Non repetitive surge peak on-state current versus number of cycles.

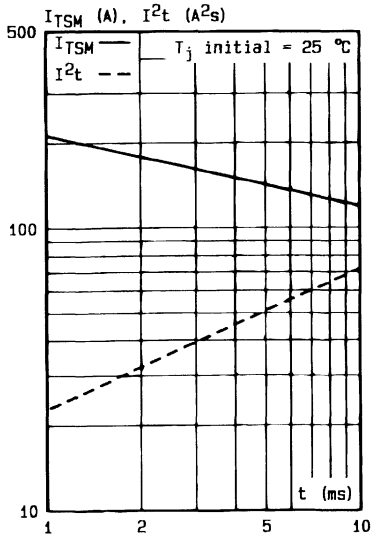

Fig.7 - Non repetitive surge peak on-state current for a sinusoidal pulse with width :  $t \leq 10$  ms, and corresponding value of  $I^2t$ .

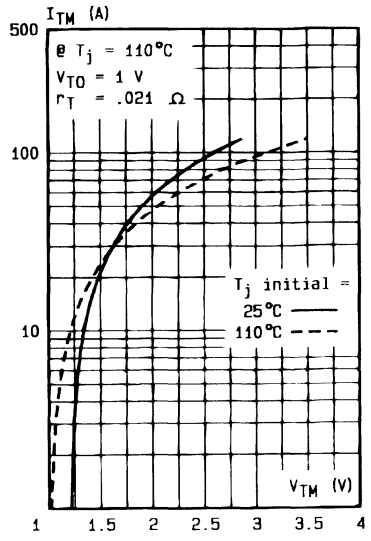
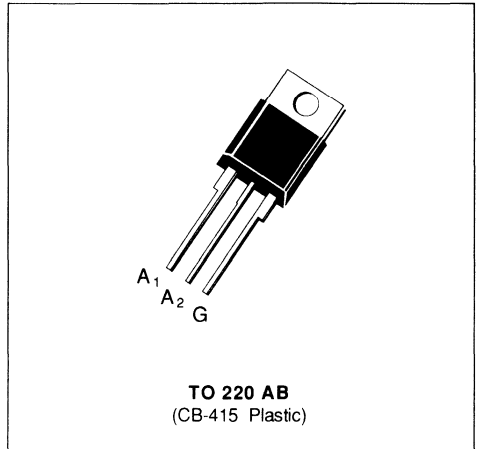

Fig.8 - On-state characteristics (maximum values).



## SNUBBERLESS TRIACS

- $I_{TRMS} = 6\text{ A}$  at  $T_c = 100\text{ }^\circ\text{C}$ .
- $V_{DRM} : 200\text{ V to } 800\text{ V}$ .
- $I_{GT} = 75\text{ mA}$  (QI-II-III).
- GLASS PASSIVATED CHIP.
- HIGH SURGE CURRENT :  $I_{TSM} = 60\text{ A}$ .
- HIGH COMMUTATION CAPABILITY :  
 $(di/dt)_c > 8\text{ A / ms}$  without snubber.



### DESCRIPTION

New range suited for applications such as phase control and static switching on inductive or resistive load.

### ABSOLUTE RATINGS (limiting values)

Symbol	Parameter		Value	Unit
$I_{TRMS}$	RMS on-state current (360 ° conduction angle)	$T_c = 100\text{ }^\circ\text{C}$	6	A
$I_{TSM}$	Non repetitive surge peak on-state current ( $T_j$ initial = 25 °C)	$t = 8.3\text{ ms}$	63	A
		$t = 10\text{ ms}$	60	
$I^2 t$	$I^2 t$ value	$t = 10\text{ ms}$	18	$A^2\text{ s}$
$di/dt$	Critical rate of rise of on-state current (1)	Repetitive $F = 50\text{ H z}$	20	$A/\mu\text{s}$
		Non Repetitive	100	
$T_{stg}$ $T_j$	Storage and operating junction temperature range		- 40, + 150 - 40, + 125	$^\circ\text{C}$ $^\circ\text{C}$

Symbol	Parameter	BTB 06-					Unit
		200 AW	400 AW	600 AW	700 AW	800 AW	
$V_{DRM}$	Repetitive peak off-state voltage (2)	$\pm 200$	$\pm 400$	$\pm 600$	$\pm 700$	$\pm 800$	V

(1) Gate supply :  $I_G = 750\text{ mA} - di_G / dt = 1\text{ A} / \mu\text{s}$ .

(2)  $T_j = 125\text{ }^\circ\text{C}$ .

## THERMAL RESISTANCES

Symbol	Parameter	Value	Unit
$R_{th(j-a)}$	Junction to ambient	60	$^{\circ}\text{C}/\text{W}$
$R_{th(j-c)}$ DC	Junction to case for DC	3.5	$^{\circ}\text{C}/\text{W}$
$R_{th(j-c)}$ AC	Junction to case for $360^{\circ}$ conduction angle ( $F = 50$ Hz)	2.7	$^{\circ}\text{C}/\text{W}$

## GATE CHARACTERISTICS (maximum values)

$P_{GM} = 40$  W ( $t = 10$   $\mu\text{s}$ )    $P_{G(AV)} = 1$  W    $I_{GM} = 4$  A ( $t = 10$   $\mu\text{s}$ )    $V_{GM} = 16$  V ( $t = 10$   $\mu\text{s}$ ).

## ELECTRICAL CHARACTERISTICS

Symbol	Test Conditions			Quadrants	Min.	Typ.	Max.	Unit
$I_{GT}$	$T_j = 25^{\circ}\text{C}$ Pulse duration > 20 $\mu\text{s}$	$V_D = 12$ V $R_L = 33$ $\Omega$		I-II-III	2		75	mA
$V_{GT}$	$T_j = 25^{\circ}\text{C}$ Pulse duration > 20 $\mu\text{s}$	$V_D = 12$ V $R_L = 33$ $\Omega$		I-II-III			1.5	V
$V_{GD}$	$T_j = 125^{\circ}\text{C}$ Pulse duration > 20 $\mu\text{s}$	$V_D = V_{DRM}$ $R_L = 3.3$ k $\Omega$		I-II-III	0.2			V
$I_{H^*}$	$T_j = 25^{\circ}\text{C}$ Gate open	$I_T = 100$ mA $R_L = 140$ $\Omega$					75	mA
$I_L$	$T_j = 25^{\circ}\text{C}$ Pulse duration > 20 $\mu\text{s}$	$V_D = 12$ V $I_G = 500$ mA		I-III		75		mA
				II		150		
$V_{TM^*}$	$T_j = 25^{\circ}\text{C}$	$I_{TM} = 8.5$ A $t_p = 10$ ms					1.75	V
$I_{DRM^*}$	$T_j = 25^{\circ}\text{C}$	$V_{DRM}$ rated Gate open					0.01	mA
	$T_j = 125^{\circ}\text{C}$						2	
$dv/dt^*$	$T_j = 125^{\circ}\text{C}$ Linear slope up to 0.67 $V_{DRM}$	Gate open			750	1000		V/ $\mu\text{s}$
$(di/dt)_c^*$	$T_j = 125^{\circ}\text{C}$ Without snubber	$V_{DRM}$ rated			8	16		A/ms
$t_{gt}$	$T_j = 25^{\circ}\text{C}$ $I_T = 8.5$ A	$di_G/dt = 3.5$ A/ $\mu\text{s}$ $V_D = V_{DRM}$	$I_G = 500$ mA	I-II-III		2		$\mu\text{s}$

\* For either polarity of electrode  $A_2$  voltage with reference to electrode  $A_1$ .

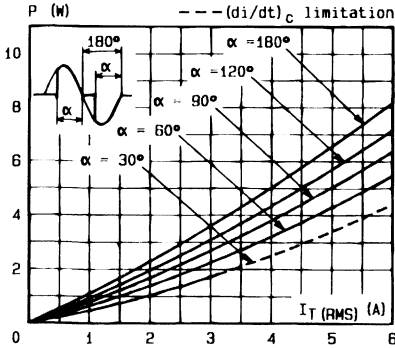

Fig. 1 - Maximum mean power dissipation versus RMS on-state current ( $F = 60$  Hz).

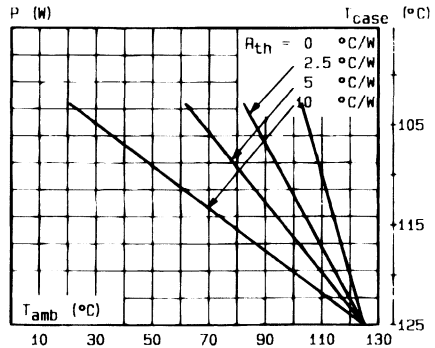

Fig. 2 - Correlation between maximum mean power dissipation and maximum allowable temperatures ( $T_{amb}$  and  $T_{case}$ ) for different thermal resistances heatsink + contact.

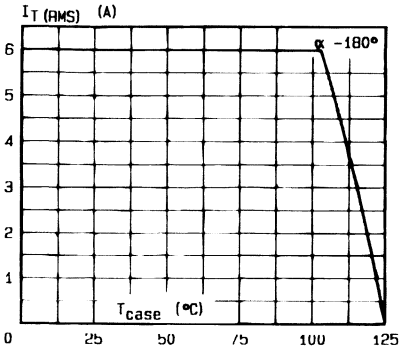

Fig. 3 - RMS on-state current versus case temperature.

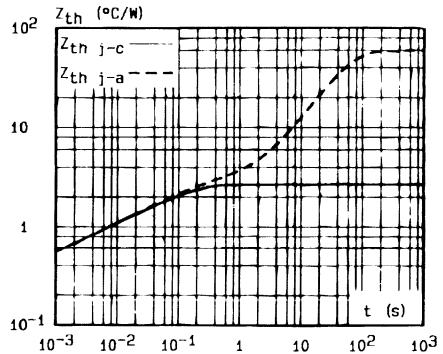

Fig. 4 - Thermal transient impedance junction to case and junction to ambient versus pulse duration.

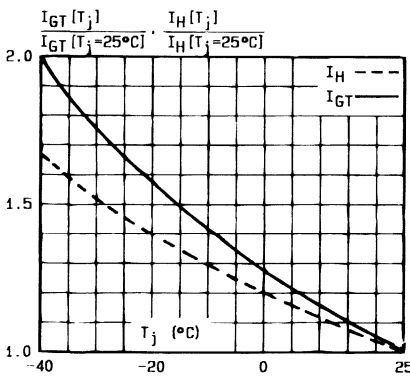

Fig 5 - Relative variation of gate trigger current and holding current versus junction temperature.

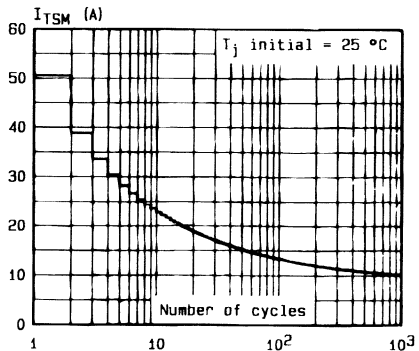

Fig.6 - Non repetitive surge peak on-state current versus number of cycles.

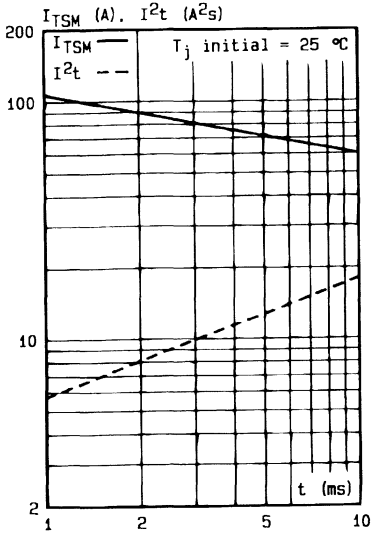

Fig.7 - Non repetitive surge peak on-state current for a sinusoidal pulse with width :  $t \leq 10$  ms, and corresponding value of  $I^2t$ .

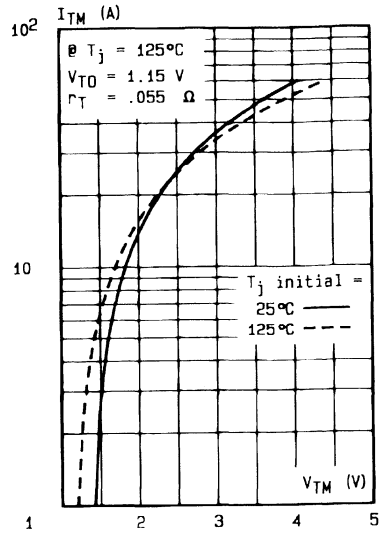
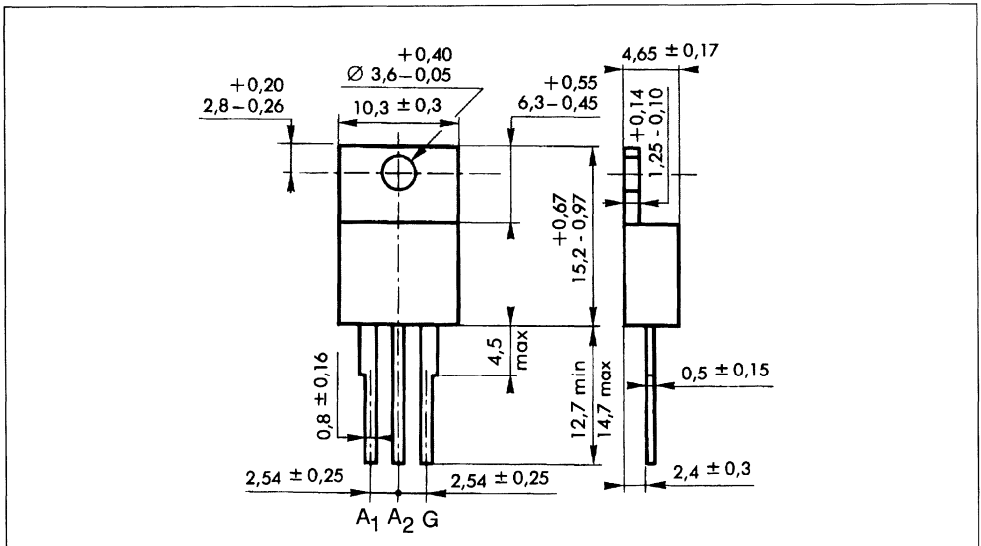

Fig.8 - On-state characteristics (maximum values).

PACKAGE MECHANICAL DATA

TO 220 AB (CB-415) Plastic



Cooling method : by conduction (method C)  
 Marking : type number  
 Weight : 2 g

## SNUBBERLESS TRIACS

- $I_{TRMS} = 6\text{ A}$  at  $T_c = 100\text{ }^\circ\text{C}$ .
- $V_{DRM} : 200\text{ V to }800\text{ V}$ .
- $I_{GT} = 50\text{ mA}$  (QI-II-III).
- GLASS PASSIVATED CHIP.
- HIGH SURGE CURRENT :  $I_{TSM} = 60\text{ A}$ .
- HIGH COMMUTATION CAPABILITY :  
 $(di/dt)_c > 5\text{ A/ms}$  without snubber.

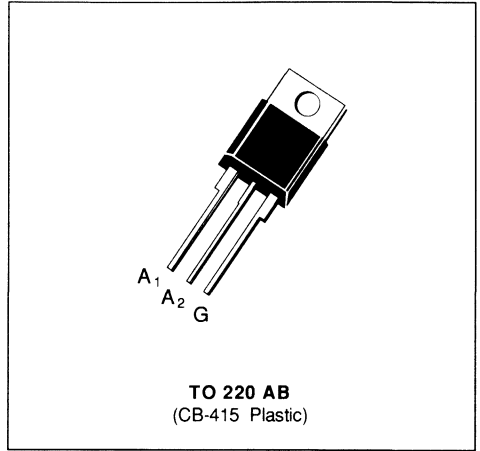

### DESCRIPTION

New range suited for applications such as phase control and static switching on inductive or resistive load.

### ABSOLUTE RATINGS (limiting values)

Symbol	Parameter		Value	Unit
$I_{TRMS}$	RMS on-state current (360 ° conduction angle)	$T_c = 100\text{ }^\circ\text{C}$	6	A
$I_{TSM}$	Non repetitive surge peak on-state current ( $T_j$ initial = 25 °C)	$t = 8.3\text{ ms}$	63	A
		$t = 10\text{ ms}$	60	
$I^2 t$	$I^2 t$ value	$t = 10\text{ ms}$	18	$\text{A}^2\text{ s}$
$di/dt$	Critical rate of rise of on-state current (1)	Repetitive $F = 50\text{ Hz}$	20	A / $\mu\text{s}$
		Non Repetitive	100	
$T_{stg}$ $T_j$	Storage and operating junction temperature range		- 40, + 150 - 40, + 125	$^\circ\text{C}$ $^\circ\text{C}$

Symbol	Parameter	BTB 06-					Unit
		200 BW	400 BW	600 BW	700 BW	800 BW	
$V_{DRM}$	Repetitive peak off-state voltage (2)	$\pm 200$	$\pm 400$	$\pm 600$	$\pm 700$	$\pm 800$	V

(1) Gate supply :  $I_G = 500\text{ mA} - di_G / dt = 1\text{ A} / \mu\text{s}$ .

(2)  $T_j = 125\text{ }^\circ\text{C}$ .

## THERMAL RESISTANCES

Symbol	Parameter	Value	Unit
$R_{th(j-a)}$	Junction to ambient	60	°C/W
$R_{th(j-c)}^{DC}$	Junction to case for DC	3.5	°C/W
$R_{th(j-c)}^{AC}$	Junction to case for 360 ° conduction angle (F = 50 Hz)	2.7	°C/W

## GATE CHARACTERISTICS (maximum values)

$P_{GM} = 40 \text{ W}$  ( $t = 10 \mu\text{s}$ )    $P_{G(AV)} = 1 \text{ W}$     $I_{GM} = 4 \text{ A}$  ( $t = 10 \mu\text{s}$ )    $V_{GM} = 16 \text{ V}$  ( $t = 10 \mu\text{s}$ ).

## ELECTRICAL CHARACTERISTICS

Symbol	Test Conditions			Quadrants	Min.	Typ.	Max.	Unit
$I_{GT}$	$T_j = 25 \text{ °C}$	$V_D = 12 \text{ V}$ Pulse duration > 20 $\mu\text{s}$	$R_L = 33 \text{ }\Omega$	I-II-III	2		50	mA
$V_{GT}$	$T_j = 25 \text{ °C}$	$V_D = 12 \text{ V}$ Pulse duration > 20 $\mu\text{s}$	$R_L = 33 \text{ }\Omega$	I-II-III			1.5	V
$V_{GD}$	$T_j = 125 \text{ °C}$	$V_D = V_{DRM}$ Pulse duration > 20 $\mu\text{s}$	$R_L = 3.3 \text{ k}\Omega$	I-II-III	0.2			V
$I_H^*$	$T_j = 25 \text{ °C}$	$I_T = 100 \text{ mA}$ Gate open	$R_L = 140 \text{ }\Omega$				50	mA
$I_L$	$T_j = 25 \text{ °C}$	$V_D = 12 \text{ V}$ Pulse duration > 20 $\mu\text{s}$	$I_G = 500 \text{ mA}$	I-III		50		mA
				II		100		
$V_{TM}^*$	$T_j = 25 \text{ °C}$	$I_{TM} = 8.5 \text{ A}$	$t_p = 10 \text{ ms}$				1.75	V
$I_{DRM}^*$	$T_j = 25 \text{ °C}$	$V_{DRM}$ rated	Gate open				0.01	mA
	$T_j = 125 \text{ °C}$						2	
$dv/dt^*$	$T_j = 125 \text{ °C}$	Gate open Linear slope up to 0.67 $V_{DRM}$			500	750		V/ $\mu\text{s}$
$(di/dt)_c^*$	$T_j = 125 \text{ °C}$	$V_{DRM}$ rated Without snubber			5	10		A / ms
$t_{gt}$	$T_j = 25 \text{ °C}$	$di_G/dt = 3.5 \text{ A}/\mu\text{s}$	$I_G = 500 \text{ mA}$	I-II-III		2		$\mu\text{s}$
	$I_T = 8.5 \text{ A}$	$V_D = V_{DRM}$						

\* For either polarity of electrode A<sub>2</sub> voltage with reference to electrode A<sub>1</sub>.

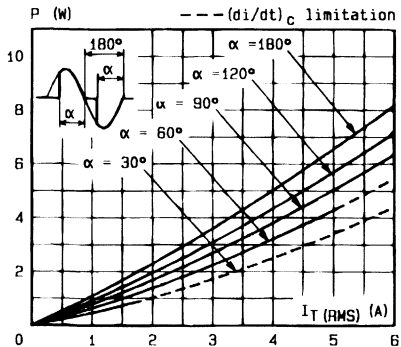

Fig.1 - Maximum mean power dissipation versus RMS on-state current ( $f = 60$  Hz).

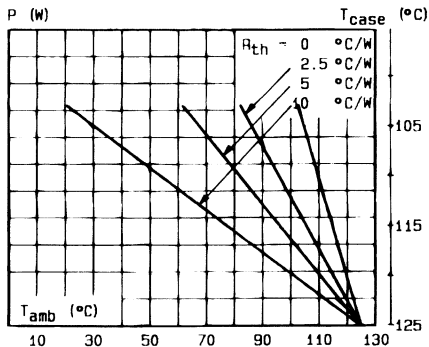

Fig.2 - Correlation between maximum mean power dissipation and maximum allowable temperatures ( $T_{amb}$  and  $T_{case}$ ) for different thermal resistances heatsink + contact.

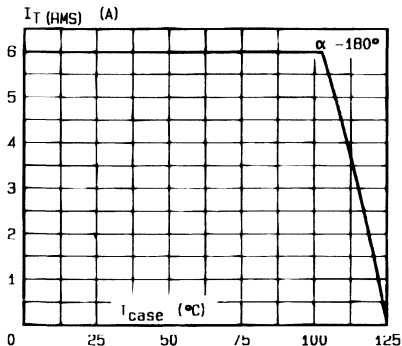

Fig.3 - RMS on-state current versus case temperature.

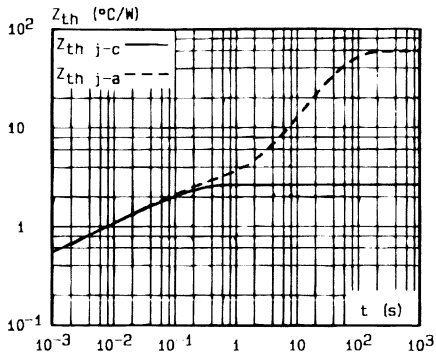

Fig.4 - Thermal transient impedance junction to case and junction to ambient versus pulse duration.

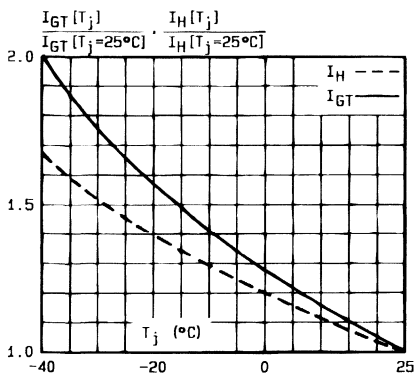

Fig.5 - Relative variation of gate trigger current and holding current versus junction temperature.

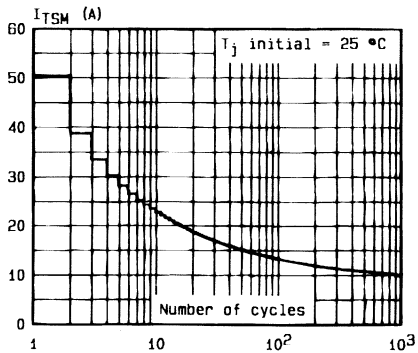

Fig.6 - Non repetitive surge peak on-state current versus number of cycles.

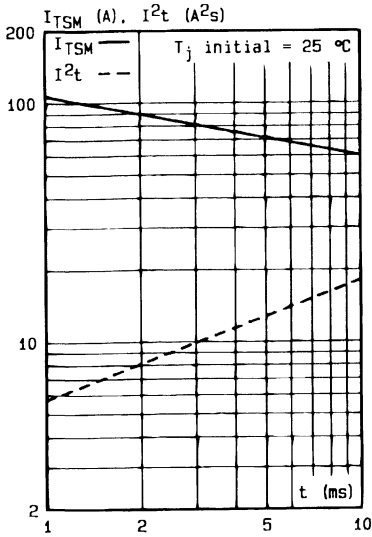

Fig.7 - Non repetitive surge peak on-state current for a sinusoidal pulse with width :  $t \leq 10$  ms. and corresponding value of  $I^2t$ .

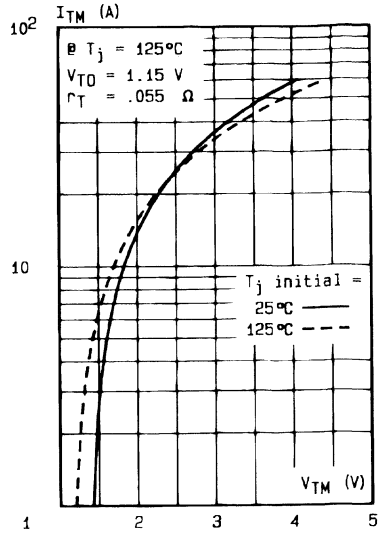
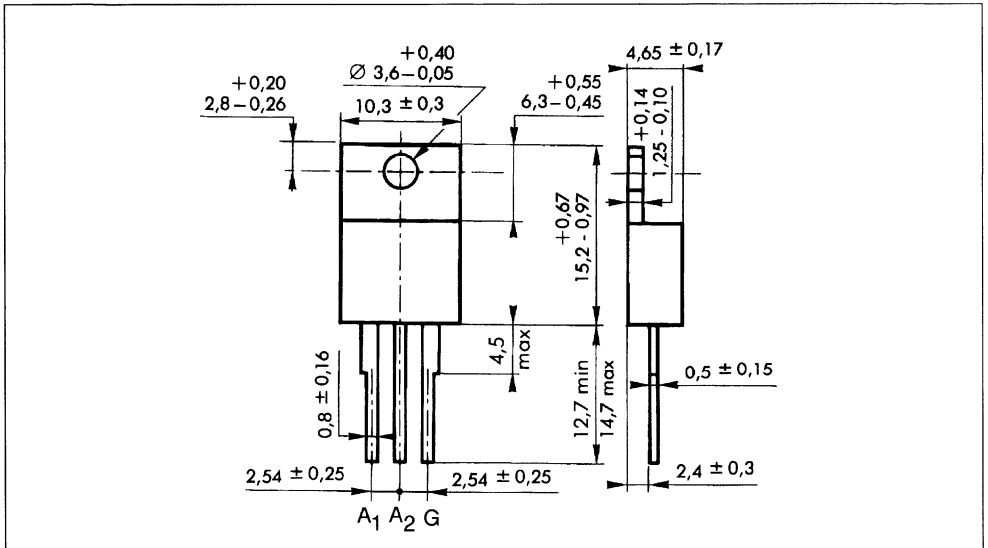

Fig.8 - On-state characteristics (maximum values).

**PACKAGE MECHANICAL DATA**

TO 220 AB (CB-415) Plastic



Cooling method : by conduction (method C)

Marking : type number

Weight : 2 g



**SNUBBERLESS TRIACS**

- $I_{TRMS} = 6\text{ A}$  at  $T_c = 100\text{ }^\circ\text{C}$ .
- $V_{DRM} : 200\text{ V}$  to  $800\text{ V}$ .
- $I_{GT} = 35\text{ mA}$  (QI-II-III).
- GLASS PASSIVATED CHIP.
- HIGH SURGE CURRENT :  $I_{TSM} = 60\text{ A}$ .
- HIGH COMMUTATION CAPABILITY :  
 $(di/dt)_c > 3.5\text{ A/ms}$  without snubber.

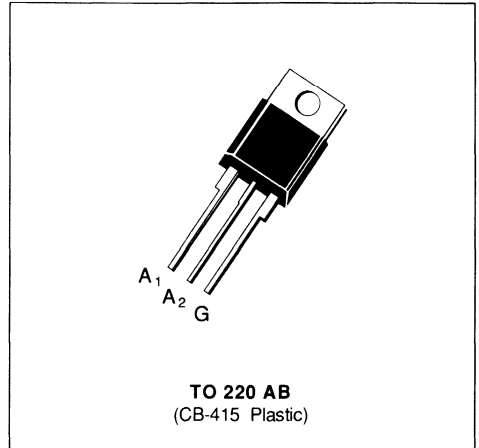
**DESCRIPTION**

New range suited for applications such as phase control and static switching on inductive or resistive load.

**ABSOLUTE RATINGS** (limiting values)

Symbol	Parameter		Value	Unit
$I_{TRMS}$	RMS on-state current (360 ° conduction angle)	$T_c = 100\text{ }^\circ\text{C}$	6	A
$I_{TSM}$	Non repetitive surge peak on-state current ( $T_j$ initial = $25\text{ }^\circ\text{C}$ )	$t = 8.3\text{ ms}$	63	A
		$t = 10\text{ ms}$	60	
$I^2 t$	$I^2 t$ value	$t = 10\text{ ms}$	18	$\text{A}^2\text{ s}$
$di/dt$	Critical rate of rise of on-state current (1)	Repetitive $F = 50\text{ Hz}$	20	A / $\mu\text{s}$
		Non Repetitive	100	
$T_{stg}$ $T_j$	Storage and operating junction temperature range		- 40, + 150 - 40, + 125	$^\circ\text{C}$ $^\circ\text{C}$

Symbol	Parameter	BTB 06-					Unit
		200 CW	400 CW	600 CW	700 CW	800 CW	
$V_{DRM}$	Repetitive peak off-state voltage (2)	$\pm 200$	$\pm 400$	$\pm 600$	$\pm 700$	$\pm 800$	V

(1) Gate supply :  $I_G = 350\text{ mA}$  -  $di_G/dt = 1\text{ A}/\mu\text{s}$ .

(2)  $T_j = 125\text{ }^\circ\text{C}$ .

**THERMAL RESISTANCES**

Symbol	Parameter	Value	Unit
$R_{th(j-a)}$	Junction to ambient	60	°C/W
$R_{th(j-c) DC}$	Junction to case for DC	3.5	°C/W
$R_{th(j-c) AC}$	Junction to case for 360° conduction angle (F = 50 Hz)	2.7	°C/W

**GATE CHARACTERISTICS (maximum values)**
 $P_{GM} = 40 \text{ W (} t = 10 \mu\text{s)}$     $P_{G(AV)} = 1 \text{ W}$     $I_{GM} = 4 \text{ A (} t = 10 \mu\text{s)}$     $V_{GM} = 16 \text{ V (} t = 10 \mu\text{s)}$ .

**ELECTRICAL CHARACTERISTICS**

Symbol	Test Conditions	Quadrants	Min.	Typ.	Max.	Unit
$I_{GT}$	$T_j = 25 \text{ °C}$ $V_D = 12 \text{ V}$ Pulse duration > 20 $\mu\text{s}$ $R_L = 33 \text{ }\Omega$	I-II-III	1		35	mA
$V_{GT}$	$T_j = 25 \text{ °C}$ $V_D = 12 \text{ V}$ Pulse duration > 20 $\mu\text{s}$ $R_L = 33 \text{ }\Omega$	I-II-III			1.5	V
$V_{GD}$	$T_j = 125 \text{ °C}$ $V_D = V_{DRM}$ Pulse duration > 20 $\mu\text{s}$ $R_L = 3.3 \text{ k}\Omega$	I-II-III	0.2			V
$I_H^*$	$T_j = 25 \text{ °C}$ $I_T = 100 \text{ mA}$ Gate open $R_L = 140 \text{ }\Omega$				35	mA
$I_L$	$T_j = 25 \text{ °C}$ $V_D = 12 \text{ V}$ Pulse duration > 20 $\mu\text{s}$ $I_G = 350 \text{ mA}$	I-III			50	mA
		II			80	
$V_{TM}^*$	$T_j = 25 \text{ °C}$ $I_{TM} = 8.5 \text{ A}$ $t_p = 10 \text{ ms}$				1.75	V
$I_{DRM}^*$	$T_j = 25 \text{ °C}$ $T_j = 125 \text{ °C}$ $V_{DRM}$ rated   Gate open				0.01	mA
					2	
$dv/dt^*$	$T_j = 125 \text{ °C}$ Gate open Linear slope up to 0.67 $V_{DRM}$		250	500		V/ $\mu\text{s}$
$(di/dt)_c^*$	$T_j = 125 \text{ °C}$ $V_{DRM}$ rated Without snubber		3.5	7		A/ms
$t_{gt}$	$T_j = 25 \text{ °C}$ $di_G/dt = 1 \text{ A}/\mu\text{s}$ $I_T = 8.5 \text{ A}$ $V_D = V_{DRM}$ $I_G = 350 \text{ mA}$	I-II-III		2		$\mu\text{s}$

\* For either polarity of electrode A<sub>2</sub> voltage with reference to electrode A<sub>1</sub>.

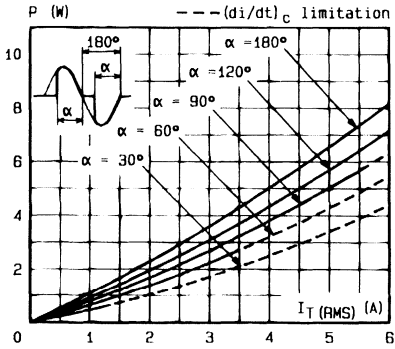

Fig.1 - Maximum mean power dissipation versus RMS on-state current ( $F = 60 \text{ Hz}$ ).

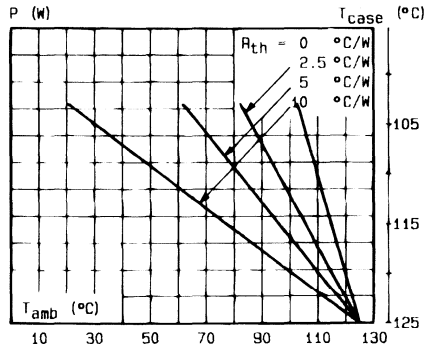

Fig.2 - Correlation between maximum mean power dissipation and maximum allowable temperatures ( $T_{amb}$  and  $T_{case}$ ) for different thermal resistances heatsink + contact.

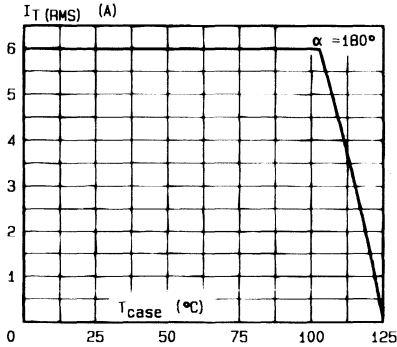

Fig.3 - RMS on-state current versus case temperature.

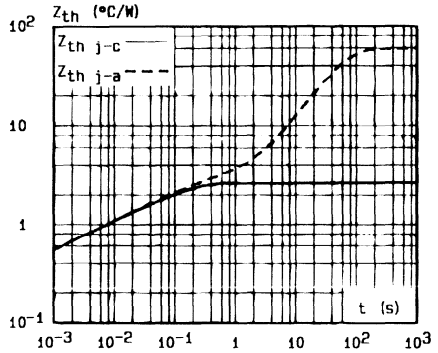

Fig.4 - Thermal transient impedance junction to case and junction to ambient versus pulse duration.

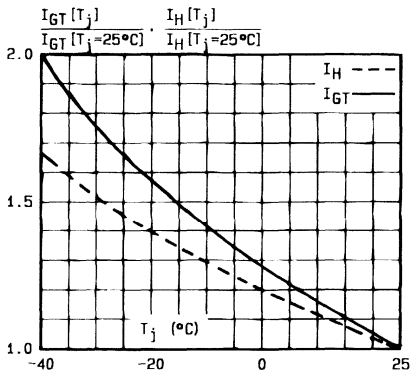

Fig.5 - Relative variation of gate trigger current and holding current versus junction temperature.

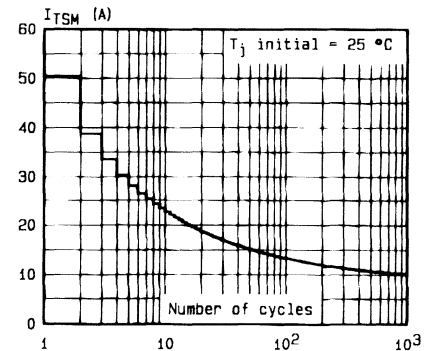

Fig.6 - Non repetitive surge peak on-state current versus number of cycles.

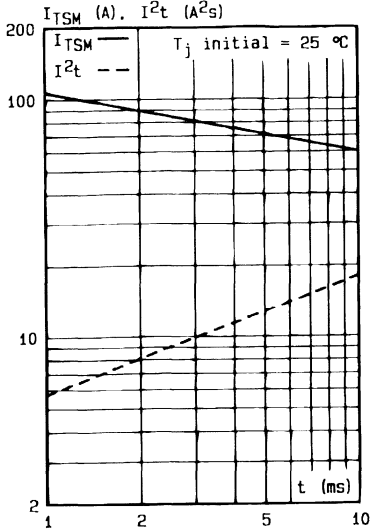

Fig.7 - Non repetitive surge peak on-state current for a sinusoidal pulse with width :  $t \leq 10 \text{ ms}$ , and corresponding value of  $I^2t$ .

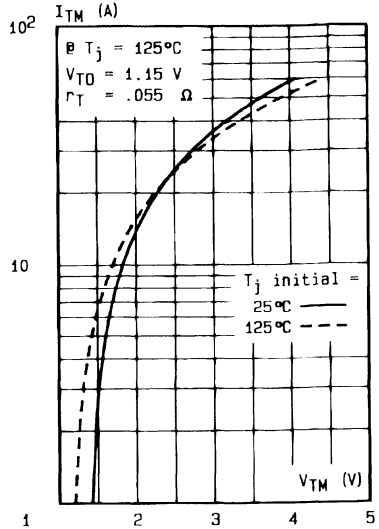
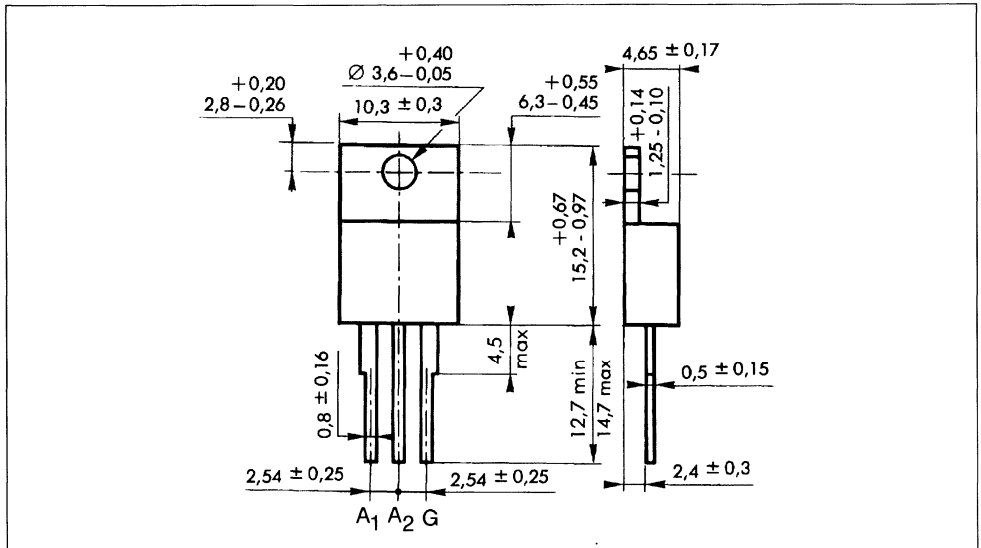

Fig.8 - On-state characteristics (maximum values).

**PACKAGE MECHANICAL DATA**

TO 220 AB (CB-415) Plastic



Cooling method : by conduction (method C)  
 Marking : type number  
 Weight : 2 g

**SNUBBERLESS TRIACS**

- $I_{TRMS} = 8\text{ A}$  at  $T_c = 95\text{ }^\circ\text{C}$ .
- $V_{DRM} : 200\text{ V}$  to  $800\text{ V}$ .
- $I_{GT} = 75\text{ mA}$  (QI-II-III).
- GLASS PASSIVATED CHIP.
- HIGH SURGE CURRENT :  $I_{TSM} = 80\text{ A}$ .
- HIGH COMMUTATION CAPABILITY :  
 $(di/dt)_c > 10\text{ A / ms}$  without snubber.

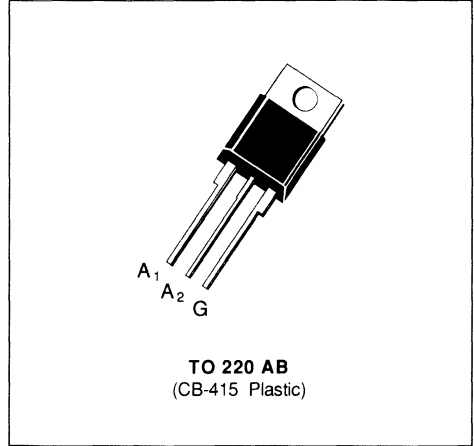
**DESCRIPTION**

New range suited for applications such as phase control and static switching on inductive or resistive load.

**ABSOLUTE RATINGS** (limiting values)

Symbol	Parameter		Value	Unit
$I_{TRMS}$	RMS on-state current (360 ° conduction angle)	$T_c = 95\text{ }^\circ\text{C}$	8	A
$I_{TSM}$	Non repetitive surge peak on-state current ( $T_j$ initial = $25\text{ }^\circ\text{C}$ )	$t = 8.3\text{ ms}$	85	A
		$t = 10\text{ ms}$	80	
$I^2t$	$I^2t$ value	$t = 10\text{ ms}$	32	$\text{A}^2\text{s}$
$di/dt$	Critical rate of rise of on-state current (1)	Repetitive $F = 50\text{ Hz}$	20	$\text{A}/\mu\text{s}$
		Non Repetitive	100	
$T_{stg}$ $T_j$	Storage and operating junction temperature range		- 40, + 150 - 40, + 125	$^\circ\text{C}$ $^\circ\text{C}$

Symbol	Parameter	BTB 08-					Unit
		200 AW	400 AW	600 AW	700 AW	800 AW	
$V_{DRM}$	Repetitive peak off-state voltage (2)	$\pm 200$	$\pm 400$	$\pm 600$	$\pm 700$	$\pm 800$	V

(1) Gate supply :  $I_G = 750\text{ mA} - di_G / dt = 1\text{ A / } \mu\text{s}$ .

(2)  $T_j = 125\text{ }^\circ\text{C}$ .

**THERMAL RESISTANCES**

Symbol	Parameter	Value	Unit
$R_{th(j-a)}$	Junction to ambient	60	°C/W
$R_{th(j-c)}^{DC}$	Junction to case for DC	3.5	°C/W
$R_{th(j-c)}^{AC}$	Junction to case for 360 ° conduction angle ( $F = 50$ Hz)	2.7	°C/W

**GATE CHARACTERISTICS (maximum values)**
 $P_{GM} = 40$  W ( $t = 10$   $\mu$ s)     $P_{G(AV)} = 1$  W     $I_{GM} = 4$  A ( $t = 10$   $\mu$ s)     $V_{GM} = 16$  V ( $t = 10$   $\mu$ s).

**ELECTRICAL CHARACTERISTICS**

Symbol	Test Conditions			Quadrants	Min.	Typ.	Max.	Unit
$I_{GT}$	$T_j = 25$ °C	$V_D = 12$ V	$R_L = 33$ $\Omega$	I-II-III	2		75	mA
	Pulse duration > 20 $\mu$ s							
$V_{GT}$	$T_j = 25$ °C	$V_D = 12$ V	$R_L = 33$ $\Omega$	I-II-III			1.5	V
	Pulse duration > 20 $\mu$ s							
$V_{GD}$	$T_j = 125$ °C	$V_D = V_{DRM}$	$R_L = 3.3$ k $\Omega$	I-II-III	0.2			V
	Pulse duration > 20 $\mu$ s							
$I_H^*$	$T_j = 25$ °C	$I_T = 100$ mA	$R_L = 140$ $\Omega$				75	mA
	Gate open							
$I_L$	$T_j = 25$ °C	$V_D = 12$ V	$I_G = 500$ mA	I-III		75		mA
				II		150		
	Pulse duration > 20 $\mu$ s							
$V_{TM}^*$	$T_j = 25$ °C	$I_{TM} = 11$ A	$t_p = 10$ ms				1.75	V
$I_{DRM}^*$	$T_j = 25$ °C	$V_{DRM}$ rated	Gate open				0.01	mA
	$T_j = 125$ °C						2	
$dv/dt^*$	$T_j = 125$ °C	Gate open			750	1000		V/ $\mu$ s
	Linear slope up to 0.67 $V_{DRM}$							
$(di/dt)_c^*$	$T_j = 125$ °C	$V_{DRM}$ rated			10	20		A/ms
	Without snubber							
$t_{gt}$	$T_j = 25$ °C	$di_G/dt = 3.5$ A/ $\mu$ s	$I_G = 500$ mA	I-II-III		2		$\mu$ s
	$I_T = 11$ A	$V_D = V_{DRM}$						

\* For either polarity of electrode  $A_2$  voltage with reference to electrode  $A_1$ .

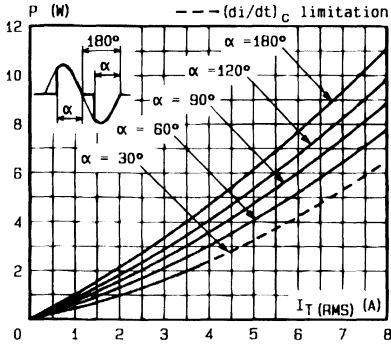

Fig. 1 - Maximum mean power dissipation versus RMS on-state current (F = 60 Hz).

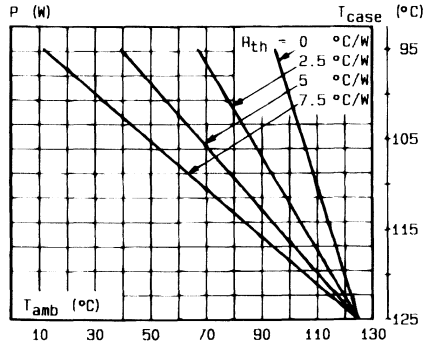

Fig. 2 - Correlation between maximum mean power dissipation and maximum allowable temperatures (T<sub>amb</sub> and T<sub>case</sub>) for different thermal resistances heatsink + contact.

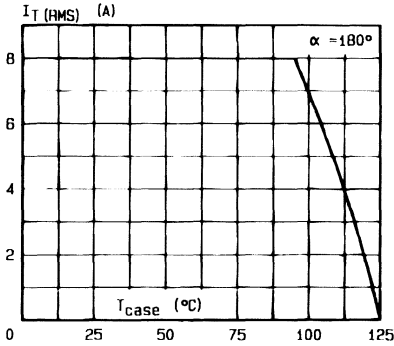

Fig. 3 - RMS on-state current versus case temperature.

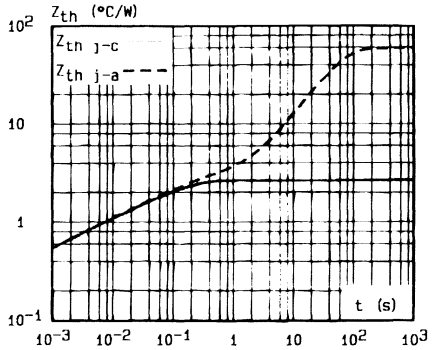

Fig. 4 - Thermal transient impedance junction to case and junction to ambient versus pulse duration.

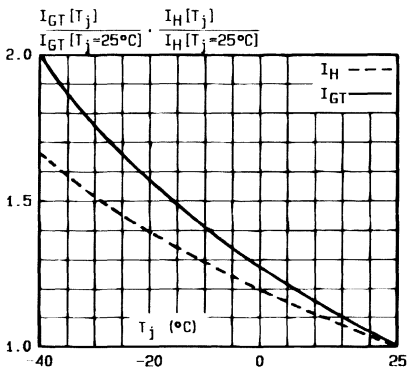

Fig. 5 - Relative variation of gate trigger current and holding current versus junction temperature.

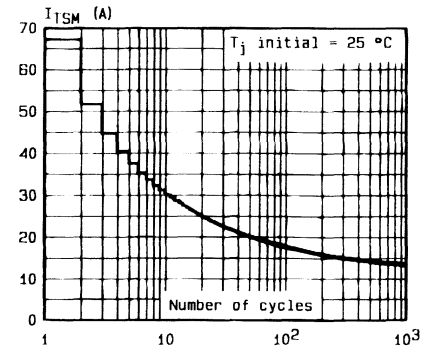

Fig. 6 - Non repetitive surge peak on-state current versus number of cycles.

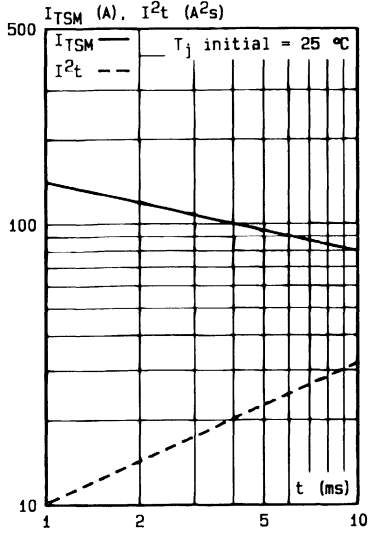

Fig.7 - Non repetitive surge peak on-state current for a sinusoidal pulse with width :  $t \leq 10$  ms, and corresponding value of  $I^2t$ .

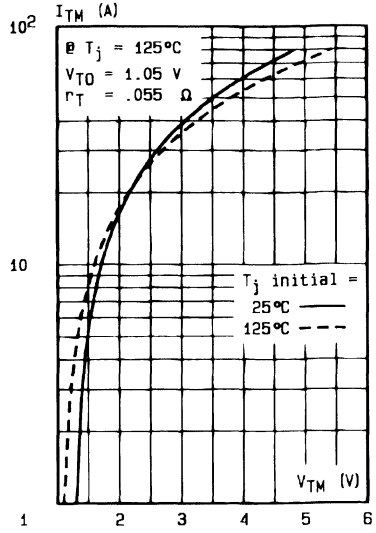
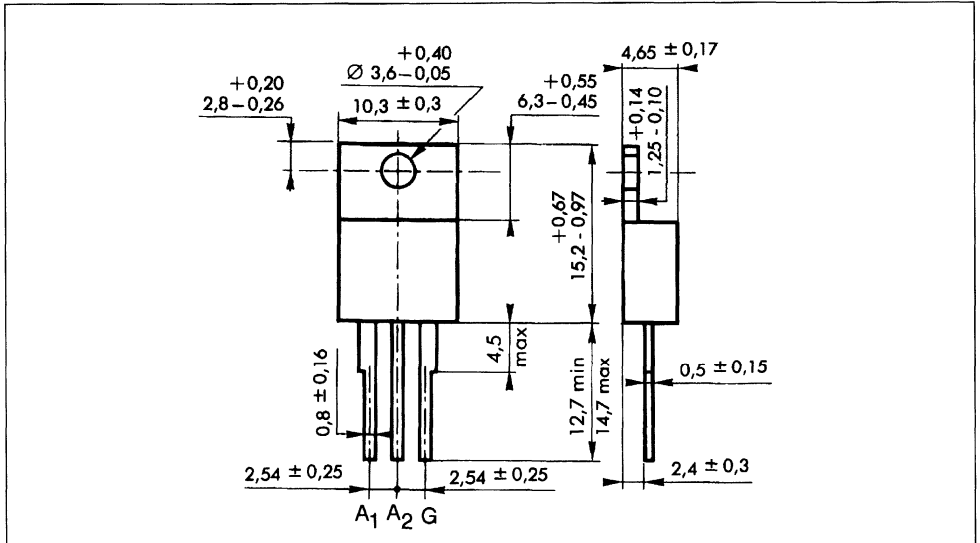

Fig.8 - On-state characteristics (maximum values).

**PACKAGE MECHANICAL DATA**

TO 220 AB (CB-415) Plastic



Cooling method : by conduction (method C)  
 Marking : type number  
 Weight : 2 g



**SNUBBERLESS TRIACS**

- $I_{TRMS} = 8\text{ A}$  at  $T_c = 95\text{ }^\circ\text{C}$ .
- $V_{DRM} : 200\text{ V}$  to  $800\text{ V}$ .
- $I_{GT} = 50\text{ mA}$  (QI-II-III).
- GLASS PASSIVATED CHIP.
- HIGH SURGE CURRENT :  $I_{TSM} = 80\text{ A}$ .
- HIGH COMMUTATION CAPABILITY :  
 $(di/dt)_c > 7\text{ A/ms}$  without snubber.

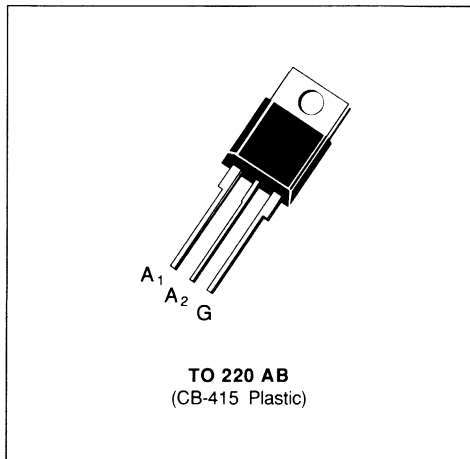
**DESCRIPTION**

New range suited for applications such as phase control and static switching on inductive or resistive load.

**ABSOLUTE RATINGS** (limiting values)

Symbol	Parameter		Value	Unit
$I_{TRMS}$	RMS on-state current (360 ° conduction angle)	$T_c = 95\text{ }^\circ\text{C}$	8	A
$I_{TSM}$	Non repetitive surge peak on-state current ( $T_j$ initial = $25\text{ }^\circ\text{C}$ )	$t = 8.3\text{ ms}$	85	A
		$t = 10\text{ ms}$	80	
$I^2t$	$I^2t$ value	$t = 10\text{ ms}$	32	$\text{A}^2\text{s}$
$di/dt$	Critical rate of rise of on-state current (1)	Repetitive $F = 50\text{ Hz}$	20	A/ $\mu\text{s}$
		Non Repetitive	100	
$T_{stg}$ $T_j$	Storage and operating junction temperature range		- 40, + 150	$^\circ\text{C}$
			- 40, + 125	$^\circ\text{C}$

Symbol	Parameter	BTB 08-					Unit
		200 BW	400 BW	600 BW	700 BW	800 BW	
$V_{DRM}$	Repetitive peak off-state voltage (2)	$\pm 200$	$\pm 400$	$\pm 600$	$\pm 700$	$\pm 800$	V

(1) Gate supply :  $I_G = 500\text{ mA}$  -  $di_G / dt = 1\text{ A} / \mu\text{s}$ .

(2)  $T_j = 125\text{ }^\circ\text{C}$ .

## THERMAL RESISTANCES

Symbol	Parameter	Value	Unit
$R_{th(j-a)}$	Junction to ambient	60	°C/W
$R_{th(j-c)}$ DC	Junction to case for DC	3.5	°C/W
$R_{th(j-c)}$ AC	Junction to case for 360 ° conduction angle (F = 50 Hz)	2.7	°C/W

## GATE CHARACTERISTICS (maximum values)

$P_{GM} = 40$  W (t = 10  $\mu$ s)    $P_{G(AV)} = 1$  W    $I_{GM} = 4$  A (t = 10  $\mu$ s)    $V_{GM} = 16$  V (t = 10  $\mu$ s).

## ELECTRICAL CHARACTERISTICS

Symbol	Test Conditions			Quadrants	Min.	Typ.	Max.	Unit
$I_{GT}$	$T_j = 25$ °C	$V_D = 12$ V	$R_L = 33$ $\Omega$	I-II-III	2		50	mA
	Pulse duration > 20 $\mu$ s							
$V_{GT}$	$T_j = 25$ °C	$V_D = 12$ V	$R_L = 33$ $\Omega$	I-II-III			1.5	V
	Pulse duration > 20 $\mu$ s							
$V_{GD}$	$T_j = 125$ °C	$V_D = V_{DRM}$	$R_L = 3.3$ k $\Omega$	I-II-III	0.2			V
	Pulse duration > 20 $\mu$ s							
$I_H^*$	$T_j = 25$ °C	$I_T = 100$ mA	$R_L = 140$ $\Omega$				50	mA
	Gate open							
$I_L$	$T_j = 25$ °C	$V_D = 12$ V	$I_G = 500$ mA	I-III		50		mA
	Pulse duration > 20 $\mu$ s			II		100		
$V_{TM}^*$	$T_j = 25$ °C	$I_{TM} = 11$ A	$t_p = 10$ ms				1.75	V
$I_{DRM}^*$	$T_j = 25$ °C	$V_{DRM}$ rated	Gate open				0.01	mA
	$T_j = 125$ °C							2
$dv/dt^*$	$T_j = 125$ °C	Gate open			500	750		V/ $\mu$ s
	Linear slope up to 0.67 $V_{DRM}$							
$(di/dt)_c^*$	$T_j = 125$ °C	$V_{DRM}$ rated			7	14		A/ms
	Without snubber							
$t_{gt}$	$T_j = 25$ °C	$di_G/dt = 3.5$ A/ $\mu$ s	$I_G = 500$ mA	I-II-III		2		$\mu$ s
	$I_T = 11$ A	$V_D = V_{DRM}$						

\* For either polarity of electrode  $A_2$  voltage with reference to electrode  $A_1$ .

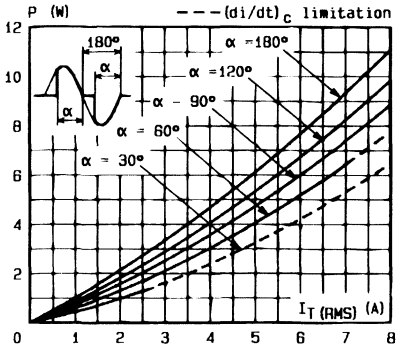

Fig. 1 - Maximum mean power dissipation versus RMS on-state current ( $F = 60$  Hz).

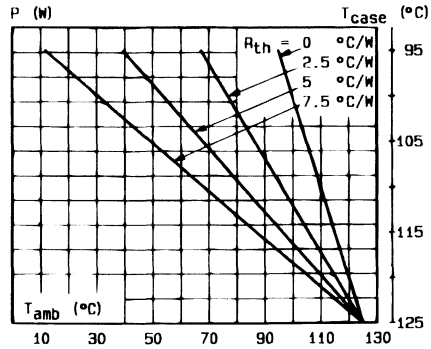

Fig. 2 - Correlation between maximum mean power dissipation and maximum allowable temperatures ( $T_{amb}$  and  $T_{case}$ ) for different thermal resistances heatsink + contact.

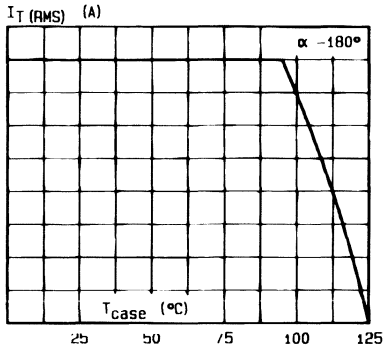

Fig. 3 - RMS on-state current versus case temperature.

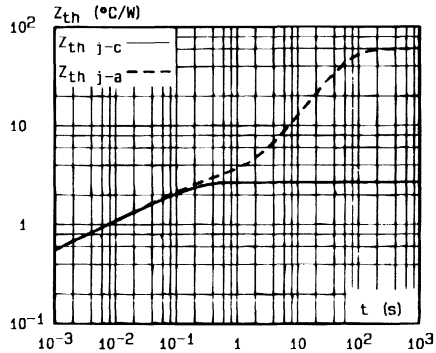

Fig. 4 - Thermal transient impedance junction to case and junction to ambient versus pulse duration.

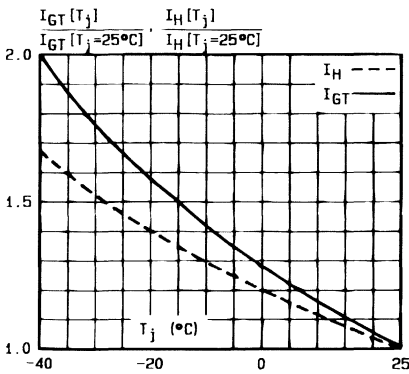

Fig. 5 - Relative variation of gate trigger current and holding current versus junction temperature.

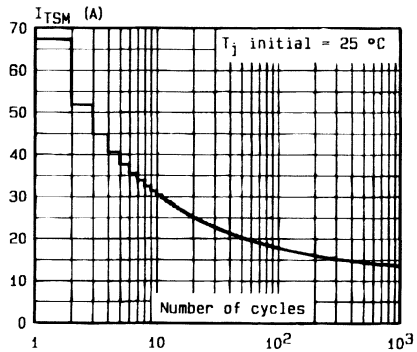

Fig. 6 - Non repetitive surge peak on-state current versus number of cycles.

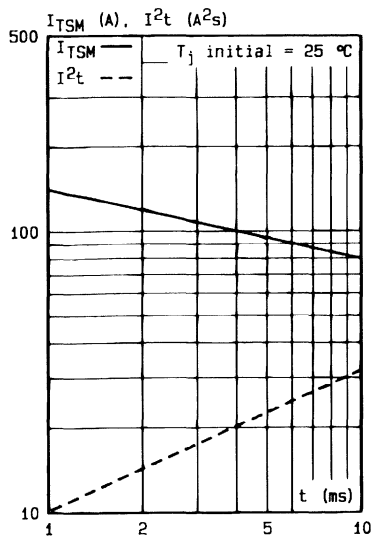

Fig.7 - Non repetitive surge peak on-state current for a sinusoidal pulse with width :  $t \leq 10$  ms, and corresponding value of  $I^2t$ .

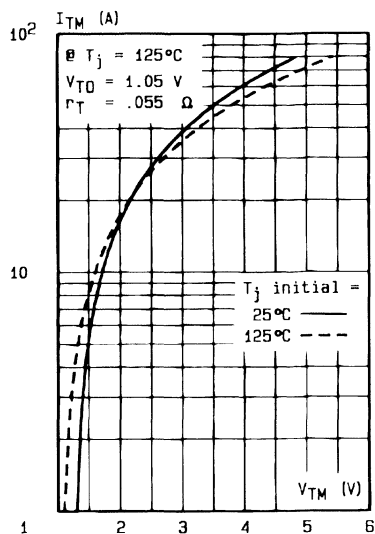
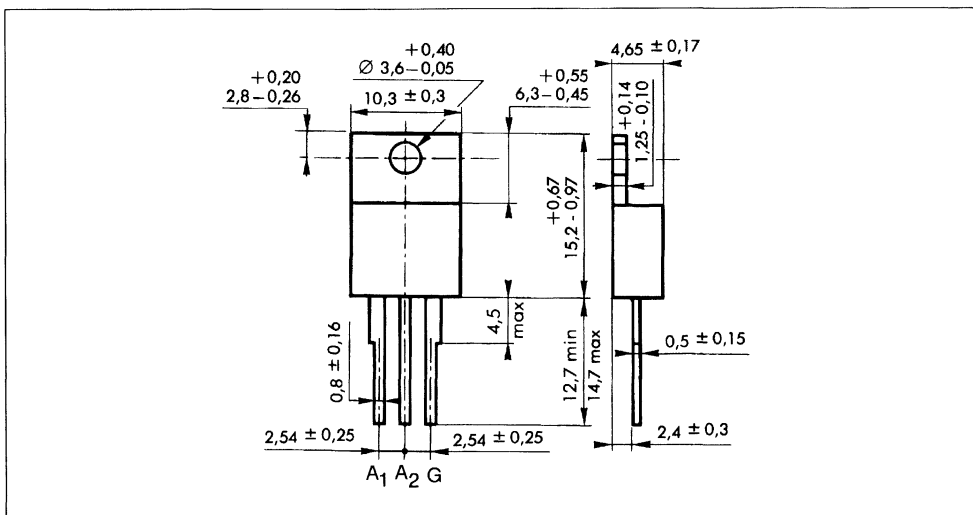

Fig.8 - On-state characteristics (maximum values).

**PACKAGE MECHANICAL DATA**

TO 220 AB (CB-415) Plastic



Cooling method : by conduction (method C)  
 Marking : type number  
 Weight : 2 g

**SNUBBERLESS TRIACS**

- $I_{TRMS} = 8\text{ A}$  at  $T_c = 95\text{ }^\circ\text{C}$ .
- $V_{DRM} : 200\text{ V}$  to  $800\text{ V}$ .
- $I_{GT} = 35\text{ mA}$  (QI-II-III).
- GLASS PASSIVATED CHIP.
- HIGH SURGE CURRENT :  $I_{TSM} = 80\text{ A}$ .
- HIGH COMMUTATION CAPABILITY :  
 $(di/dt)_c > 4.5\text{ A/ms}$  without snubber.

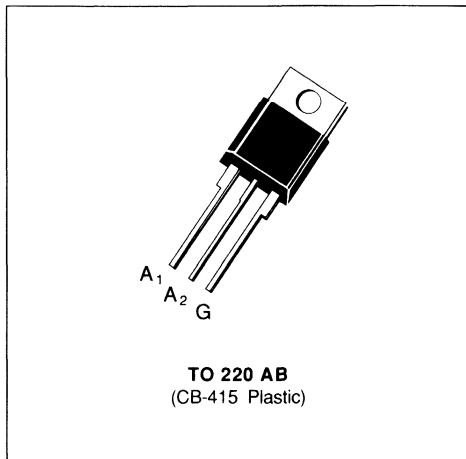
**DESCRIPTION**

New range suited for applications such as phase control and static switching on inductive or resistive load.

**ABSOLUTE RATINGS** (limiting values)

Symbol	Parameter		Value	Unit
$I_{TRMS}$	RMS on-state current (360 ° conduction angle)	$T_c = 95\text{ }^\circ\text{C}$	8	A
$I_{TSM}$	Non repetitive surge peak on-state current ( $T_j$ initial = $25\text{ }^\circ\text{C}$ )	$t = 8.3\text{ ms}$	85	A
		$t = 10\text{ ms}$	80	
$I^2t$	$I^2t$ value	$t = 10\text{ ms}$	32	$\text{A}^2\text{s}$
$di/dt$	Critical rate of rise of on-state current (1)	Repetitive $F = 50\text{ Hz}$	20	A/ $\mu\text{s}$
		Non Repetitive	100	
$T_{stg}$ $T_j$	Storage and operating junction temperature range		- 40, + 150 - 40, + 125	$^\circ\text{C}$ $^\circ\text{C}$

Symbol	Parameter	BTB 08-					Unit
		200 CW	400 CW	600 CW	700 CW	800 CW	
$V_{DRM}$	Repetitive peak off-state voltage (2)	$\pm 200$	$\pm 400$	$\pm 600$	$\pm 700$	$\pm 800$	V

(1) Gate supply :  $I_G = 350\text{ mA}$  -  $di_G / dt = 1\text{ A} / \mu\text{s}$ .

(2)  $T_j = 125\text{ }^\circ\text{C}$ .

## THERMAL RESISTANCES

Symbol	Parameter	Value	Unit
$R_{th(j-a)}$	Junction to ambient	60	°C/W
$R_{th(j-c)}$ DC	Junction to case for DC	3.5	°C/W
$R_{th(j-c)}$ AC	Junction to case for 360 ° conduction angle (F = 50 Hz)	2.7	°C/W

## GATE CHARACTERISTICS (maximum values)

$P_{GM} = 40 \text{ W}$  ( $t = 10 \mu\text{s}$ )    $P_{G(AV)} = 1 \text{ W}$     $I_{GM} = 4 \text{ A}$  ( $t = 10 \mu\text{s}$ )    $V_{GM} = 16 \text{ V}$  ( $t = 10 \mu\text{s}$ ).

## ELECTRICAL CHARACTERISTICS

Symbol	Test Conditions	Quadrants	Min.	Typ.	Max.	Unit	
$I_{GT}$	$T_J = 25 \text{ °C}$ $V_D = 12 \text{ V}$ Pulse duration > 20 $\mu\text{s}$ $R_L = 33 \Omega$	I-II-III	1		35	mA	
$V_{GT}$	$T_J = 25 \text{ °C}$ $V_D = 12 \text{ V}$ Pulse duration > 20 $\mu\text{s}$ $R_L = 33 \Omega$	I-II-III			1.5	V	
$V_{GD}$	$T_J = 125 \text{ °C}$ $V_D = V_{DRM}$ Pulse duration > 20 $\mu\text{s}$ $R_L = 3.3 \text{ k}\Omega$	I-II-III	0.2			V	
$I_H^*$	$T_J = 25 \text{ °C}$ $I_T = 100 \text{ mA}$ Gate open $R_L = 140 \Omega$				35	mA	
$I_L$	$T_J = 25 \text{ °C}$ $V_D = 12 \text{ V}$ Pulse duration > 20 $\mu\text{s}$ $I_G = 350 \text{ mA}$	I-III			50	mA	
		II			80		
$V_{TM}^*$	$T_J = 25 \text{ °C}$ $I_{TM} = 11 \text{ A}$ $t_p = 10 \text{ ms}$				1.75	V	
$I_{DRM}^*$	$T_J = 25 \text{ °C}$ $T_J = 125 \text{ °C}$	$V_{DRM}$ rated	Gate open			0.01	mA
						2	
$dv/dt^*$	$T_J = 125 \text{ °C}$ Gate open Linear slope up to 0.67 $V_{DRM}$		250	500		V/ $\mu\text{s}$	
$(di/dt)_c^*$	$T_J = 125 \text{ °C}$ $V_{DRM}$ rated Without snubber		4.5	9		A/ms	
$t_{gt}$	$T_J = 25 \text{ °C}$ $di_G/dt = 1 \text{ A}/\mu\text{s}$ $I_T = 11 \text{ A}$ $V_D = V_{DRM}$	I-II-III		2		$\mu\text{s}$	

\* For either polarity of electrode A<sub>2</sub>; voltage with reference to electrode A<sub>1</sub>.

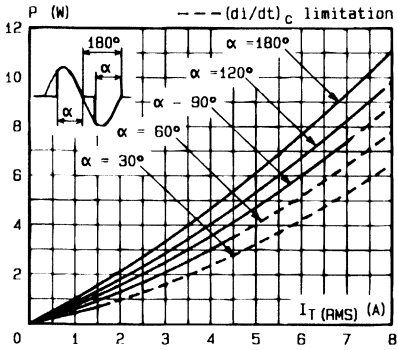

Fig.1 - Maximum mean power dissipation versus RMS on-state current ( $F = 60$  Hz).

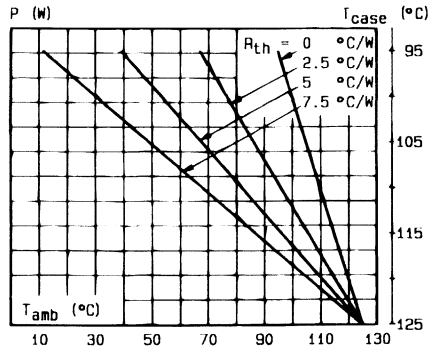

Fig.2 - Correlation between maximum mean power dissipation and maximum allowable temperatures ( $T_{amb}$  and  $T_{case}$ ) for different thermal resistances heatsink + contact.

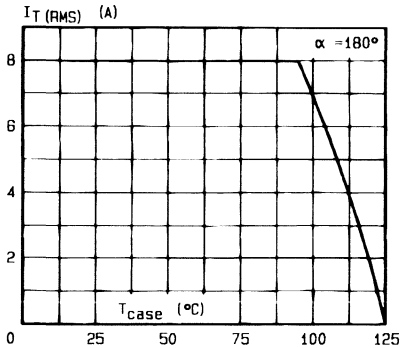

Fig.3 - RMS on-state current versus case temperature.

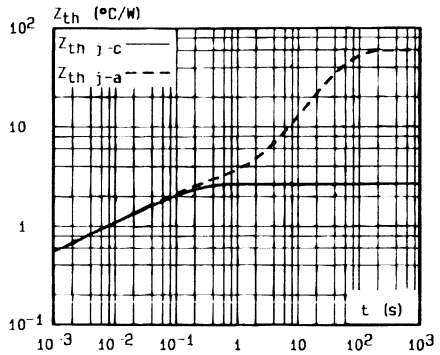

Fig.4 - Thermal transient impedance junction to case and junction to ambient versus pulse duration.

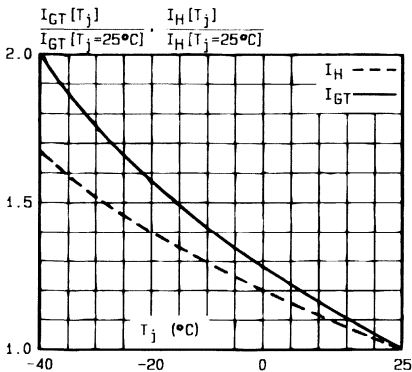

Fig.5 - Relative variation of gate trigger current and holding current versus junction temperature.

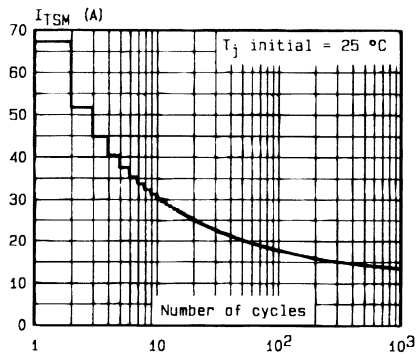

Fig.6 - Non repetitive surge peak on-state current versus number of cycles.

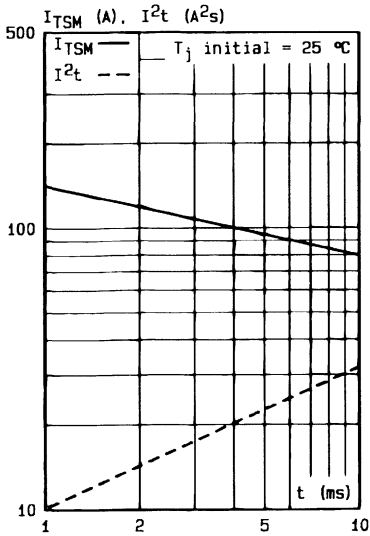

Fig.7 - Non repetitive surge peak on-state current for a sinusoidal pulse with width :  $t \leq 10$  ms, and corresponding value of  $I^2t$ .

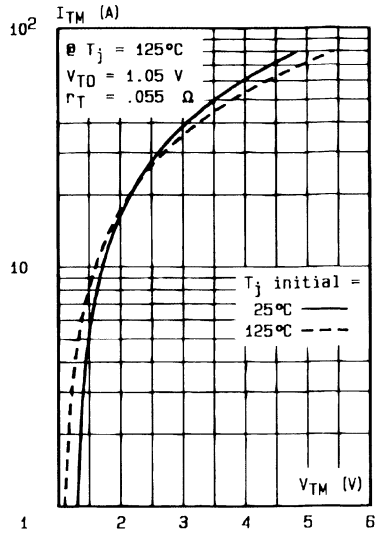
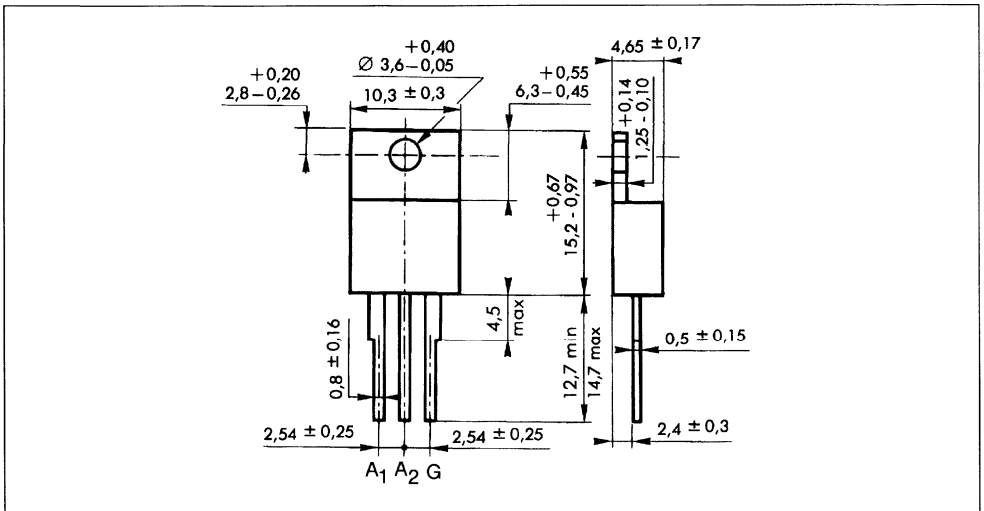

Fig.8 - On-state characteristics (maximum values).

**PACKAGE MECHANICAL DATA**

TO 220 AB (CB-415) Plastic



Cooling method : by conduction (method C)

Marking : type number

Weight : 2 g



**SNUBBERLESS TRIACS**

- $I_{TRMS} = 10\text{ A}$  at  $T_c = 100\text{ }^\circ\text{C}$ .
- $V_{DRM} : 200\text{ V}$  to  $800\text{ V}$ .
- $I_{GT} = 75\text{ mA}$  (QI-II-III).
- GLASS PASSIVATED CHIP.
- HIGH SURGE CURRENT :  $I_{TSM} = 100\text{ A}$ .
- HIGH COMMUTATION CAPABILITY :  
 $(di/dt)_c > 12\text{ A/ms}$  without snubber.

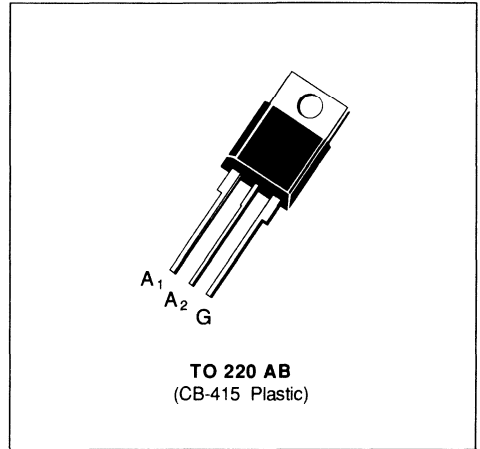
**DESCRIPTION**

New range suited for applications such as phase control and static switching on inductive or resistive load.

**ABSOLUTE RATINGS** (limiting values)

Symbol	Parameter		Value	Unit
$I_{TRMS}$	RMS on-state current (360 ° conduction angle)	$T_c = 100\text{ }^\circ\text{C}$	10	A
$I_{TSM}$	Non repetitive surge peak on-state current ( $T_j$ initial = 25 °C)	$t = 8.3\text{ ms}$	105	A
		$t = 10\text{ ms}$	100	
$I^2t$	$I^2t$ value	$t = 10\text{ ms}$	50	$\text{A}^2\text{s}$
$di/dt$	Critical rate of rise of on-state current (1)	Repetitive $F = 50\text{ Hz}$	20	A/ $\mu\text{s}$
		Non Repetitive	100	
$T_{stg}$ $T_j$	Storage and operating junction temperature range		- 40, + 150 - 40, + 125	$^\circ\text{C}$ $^\circ\text{C}$

Symbol	Parameter	BTB 10-					Unit
		200 AW	400 AW	600 AW	700 AW	800 AW	
$V_{DRM}$	Repetitive peak off-state voltage (2)	$\pm 200$	$\pm 400$	$\pm 600$	$\pm 700$	$\pm 800$	V

(1) Gate supply :  $I_G = 750\text{ mA}$  –  $di_G/dt = 1\text{ A}/\mu\text{s}$ .

(2)  $T_j = 125\text{ }^\circ\text{C}$ .

## THERMAL RESISTANCES

Symbol	Parameter	Value	Unit
$R_{th(j-a)}$	Junction to ambient	60	$^{\circ}\text{C}/\text{W}$
$R_{th(j-c)} \text{ DC}$	Junction to case for DC	2.7	$^{\circ}\text{C}/\text{W}$
$R_{th(j-c)} \text{ AC}$	Junction to case for $360^{\circ}$ conduction angle ( $F = 50 \text{ Hz}$ )	2	$^{\circ}\text{C}/\text{W}$

## GATE CHARACTERISTICS (maximum values)

$P_{GM} = 40 \text{ W}$  ( $t = 10 \mu\text{s}$ )    $P_{G(AV)} = 1 \text{ W}$     $I_{GM} = 4 \text{ A}$  ( $t = 10 \mu\text{s}$ )    $V_{GM} = 16 \text{ V}$  ( $t = 10 \mu\text{s}$ ).

## ELECTRICAL CHARACTERISTICS

Symbol	Test Conditions			Quadrants	Min.	Typ.	Max.	Unit
$I_{GT}$	$T_j = 25^{\circ}\text{C}$	$V_D = 12 \text{ V}$	$R_L = 33 \Omega$	I-II-III	2		75	mA
	Pulse duration $> 20 \mu\text{s}$							
$V_{GT}$	$T_j = 25^{\circ}\text{C}$	$V_D = 12 \text{ V}$	$R_L = 33 \Omega$	I-II-III			1.5	V
	Pulse duration $> 20 \mu\text{s}$							
$V_{GD}$	$T_j = 125^{\circ}\text{C}$	$V_D = V_{DRM}$	$R_L = 3.3 \text{ k}\Omega$	I-II-III	0.2			V
	Pulse duration $> 20 \mu\text{s}$							
$I_{H^*}$	$T_j = 25^{\circ}\text{C}$	$I_T = 100 \text{ mA}$	$R_L = 140 \Omega$				75	mA
	Gate open							
$I_L$	$T_j = 25^{\circ}\text{C}$	$V_D = 12 \text{ V}$	$I_G = 500 \text{ mA}$	I-III		75		mA
				II		150		
	Pulse duration $> 20 \mu\text{s}$							
$V_{TM^*}$	$T_j = 25^{\circ}\text{C}$	$I_{TM} = 14 \text{ A}$	$t_p = 10 \text{ ms}$				1.65	V
$I_{DRM^*}$	$T_j = 25^{\circ}\text{C}$	$V_{DRM}$ rated	Gate open				0.01	mA
	$T_j = 125^{\circ}\text{C}$						2	
$dv/dt^*$	$T_j = 125^{\circ}\text{C}$	Gate open			750	1000		$\text{V}/\mu\text{s}$
	Linear slope up to $0.67 V_{DRM}$							
$(di/dt)_c^*$	$T_j = 125^{\circ}\text{C}$	$V_{DRM}$ rated			12	24		A/ms
	Without snubber							
$t_{gt}$	$T_j = 25^{\circ}\text{C}$	$di_G/dt = 3.5 \text{ A}/\mu\text{s}$	$I_G = 500 \text{ mA}$	I-II-III		2		$\mu\text{s}$
	Pulse duration $> 20 \mu\text{s}$							

\* For either polarity of electrode  $A_2$  voltage with reference to electrode  $A_1$ .

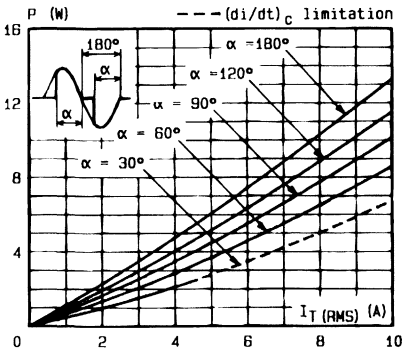

Fig. 1 - Maximum mean power dissipation versus RMS on-state current ( $f = 60$  Hz).

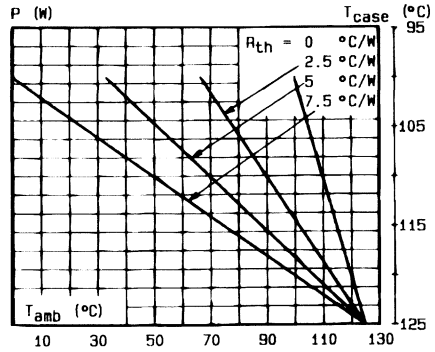

Fig. 2 - Correlation between maximum mean power dissipation and maximum allowable temperatures ( $T_{amb}$  and  $T_{case}$ ) for different thermal resistances heatsink + contact.

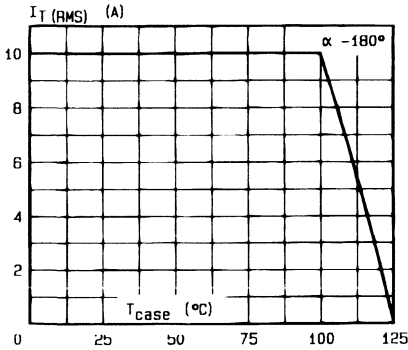

Fig. 3 - RMS on-state current versus case temperature.

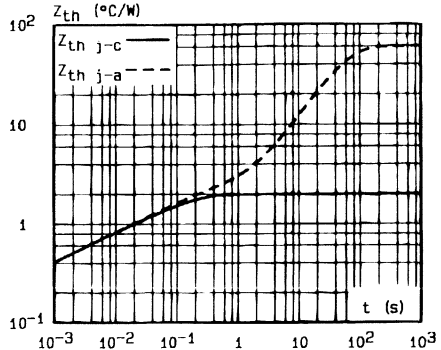

Fig. 4 - Thermal transient impedance junction to case and junction to ambient versus pulse duration.

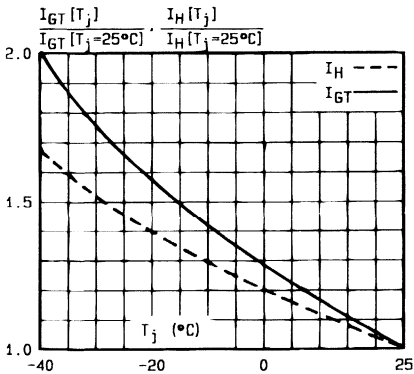

Fig. 5 - Relative variation of gate trigger current and holding current versus junction temperature.

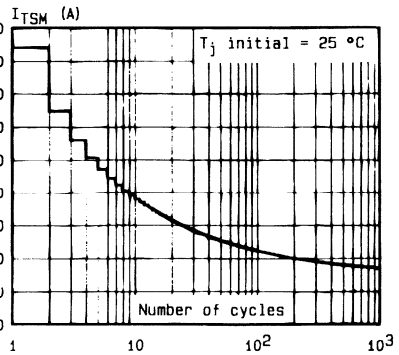

Fig. 6 - Non repetitive surge peak on-state current versus number of cycles.

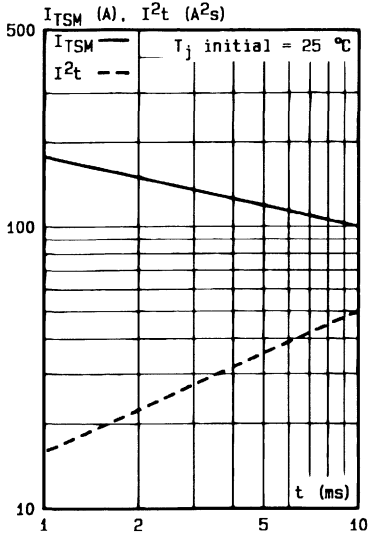

Fig.7 - Non repetitive surge peak on-state current for a sinusoidal pulse with width :  $t \leq 10$  ms, and corresponding value of  $I^2t$ .

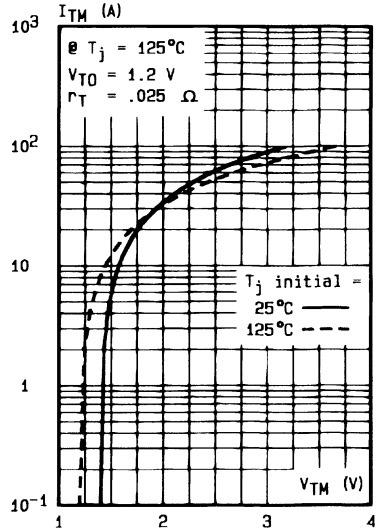
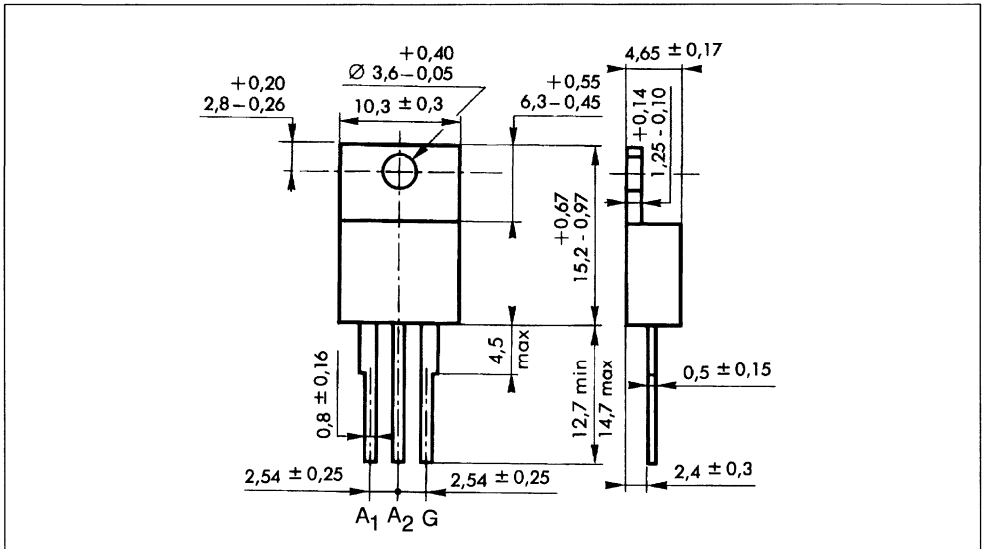

Fig.8 - On-state characteristics (maximum values).

PACKAGE MECHANICAL DATA

TO 220 AB (CB-415) Plastic



Cooling method : by conduction (method C)  
 Marking : type number  
 Weight : 2 g

**SNUBBERLESS TRIACS**

- $I_{TRMS} = 10 \text{ A}$  at  $T_c = 100 \text{ }^\circ\text{C}$ .
- $V_{DRM} : 200 \text{ V}$  to  $800 \text{ V}$ .
- $I_{GT} = 50 \text{ mA}$  (QI-II-III).
- GLASS PASSIVATED CHIP.
- HIGH SURGE CURRENT :  $I_{TSM} = 100 \text{ A}$ .
- HIGH COMMUTATION CAPABILITY :  
 $(di/dt)_c > 9 \text{ A / ms}$  without snubber.

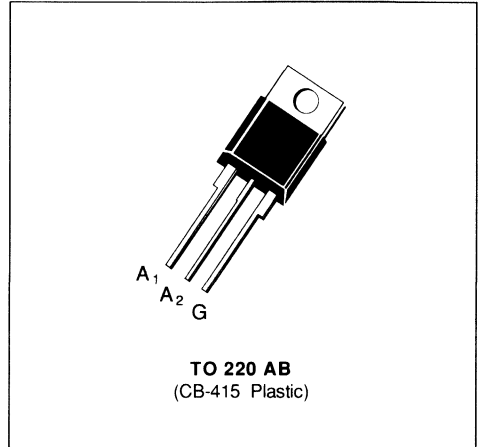
**DESCRIPTION**

New range suited for applications such as phase control and static switching on inductive or resistive load.

**ABSOLUTE RATINGS** (limiting values)

Symbol	Parameter		Value	Unit
$I_{TRMS}$	RMS on-state current (360 ° conduction angle)	$T_c = 100 \text{ }^\circ\text{C}$	10	A
$I_{TSM}$	Non repetitive surge peak on-state current ( $T_j$ initial = $25 \text{ }^\circ\text{C}$ )	$t = 8.3 \text{ ms}$	105	A
		$t = 10 \text{ ms}$	100	
$I^2t$	$I^2t$ value	$t = 10 \text{ ms}$	50	$\text{A}^2\text{s}$
$di/dt$	Critical rate of rise of on-state current (1)	Repetitive $F = 50 \text{ Hz}$	20	A / $\mu\text{s}$
		Non Repetitive	100	
$T_{stg}$ $T_j$	Storage and operating junction temperature range		- 40, + 150 - 40, + 125	$^\circ\text{C}$ $^\circ\text{C}$

Symbol	Parameter	BTB 10-					Unit
		200 BW	400 BW	600 BW	700 BW	800 BW	
$V_{DRM}$	Repetitive peak off-state voltage (2)	$\pm 200$	$\pm 400$	$\pm 600$	$\pm 700$	$\pm 800$	V

(1) Gate supply :  $I_G = 500 \text{ mA}$  -  $di_G / dt = 1 \text{ A / } \mu\text{s}$ .

(2)  $T_j = 125 \text{ }^\circ\text{C}$ .

**THERMAL RESISTANCES**

Symbol	Parameter	Value	Unit
$R_{th(j-a)}$	Junction to ambient	60	°C/W
$R_{th(j-c)DC}$	Junction to case for DC	2.7	°C/W
$R_{th(j-c)AC}$	Junction to case for 360° conduction angle (F = 50 Hz)	2	°C/W

**GATE CHARACTERISTICS (maximum values)**
 $P_{GM} = 40 \text{ W (} t = 10 \mu\text{s)}$     $P_{G(AV)} = 1 \text{ W}$     $I_{GM} = 4 \text{ A (} t = 10 \mu\text{s)}$     $V_{GM} = 16 \text{ V (} t = 10 \mu\text{s)}$ .

**ELECTRICAL CHARACTERISTICS**

Symbol	Test Conditions			Quadrants	Min.	Typ.	Max.	Unit
$I_{GT}$	$T_j = 25 \text{ °C}$ Pulse duration > 20 $\mu\text{s}$	$V_D = 12 \text{ V}$	$R_L = 33 \ \Omega$	I-II-III	2		50	mA
$V_{GT}$	$T_j = 25 \text{ °C}$ Pulse duration > 20 $\mu\text{s}$	$V_D = 12 \text{ V}$	$R_L = 33 \ \Omega$	I-II-III			1.5	V
$V_{GD}$	$T_j = 125 \text{ °C}$ Pulse duration > 20 $\mu\text{s}$	$V_D = V_{DRM}$	$R_L = 3.3 \text{ k}\Omega$	I-II-III	0.2			V
$I_H^*$	$T_j = 25 \text{ °C}$ Gate open	$I_T = 100 \text{ mA}$ $R_L = 140 \ \Omega$					50	mA
$I_L$	$T_j = 25 \text{ °C}$ Pulse duration > 20 $\mu\text{s}$	$V_D = 12 \text{ V}$	$I_G = 500 \text{ mA}$	I-III		50		mA
				II		100		
$V_{TM}^*$	$T_j = 25 \text{ °C}$	$I_{TM} = 14 \text{ A}$	$t_p = 10 \text{ ms}$				1.65	V
$I_{DRM}^*$	$T_j = 25 \text{ °C}$	$V_{DRM}$ rated	Gate open				0.01	mA
	$T_j = 125 \text{ °C}$						2	
$dv/dt^*$	$T_j = 125 \text{ °C}$ Linear slope up to 0.67 $V_{DRM}$	Gate open			500	750		V/ $\mu\text{s}$
$(di/dt)_c^*$	$T_j = 125 \text{ °C}$ Without snubber	$V_{DRM}$ rated			9	18		A/ms
$t_{gt}$	$T_j = 25 \text{ °C}$ $I_T = 14 \text{ A}$	$di_G/dt = 3.5 \text{ A}/\mu\text{s}$ $V_D = V_{DRM}$	$I_G = 500 \text{ mA}$	I-II-III		2		$\mu\text{s}$

\* For either polarity of electrode A<sub>2</sub> voltage with reference to electrode A<sub>1</sub>.

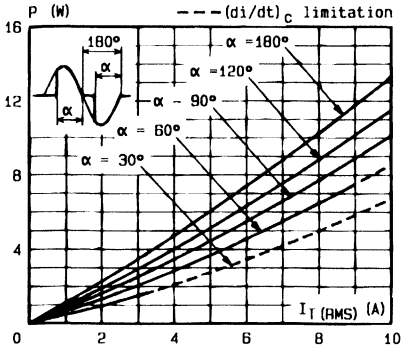

Fig. 1 - Maximum mean power dissipation versus RMS on-state current ( $F = 60$  Hz).

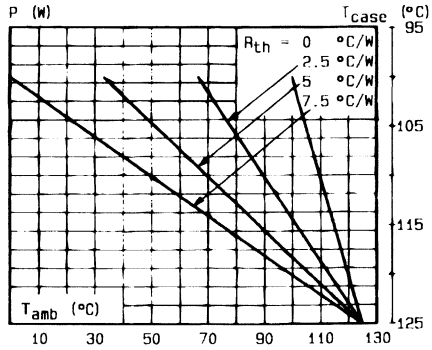

Fig. 2 - Correlation between maximum mean power dissipation and maximum allowable temperatures ( $T_{amb}$  and  $T_{case}$ ) for different thermal resistances heatsink + contact.

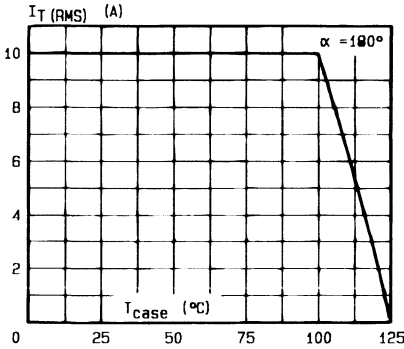

Fig. 3 - RMS on-state current versus case temperature.

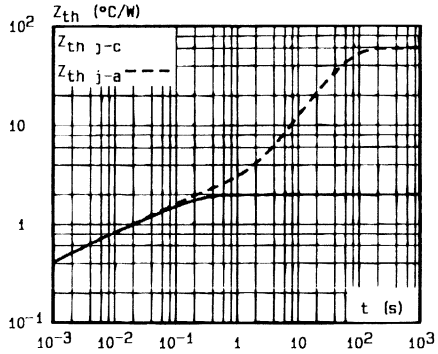

Fig. 4 - Thermal transient impedance junction to case and junction to ambient versus pulse duration.

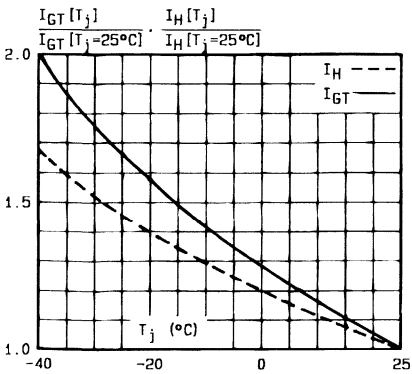

Fig. 5 - Relative variation of gate trigger current and holding current versus junction temperature.

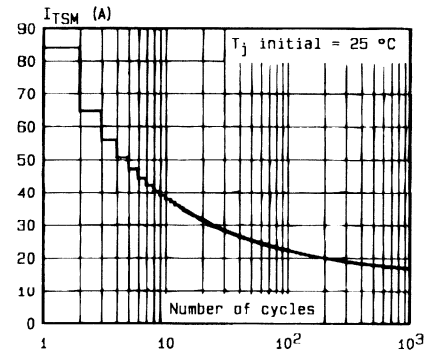

Fig. 6 - Non repetitive surge peak on-state current versus number of cycles.

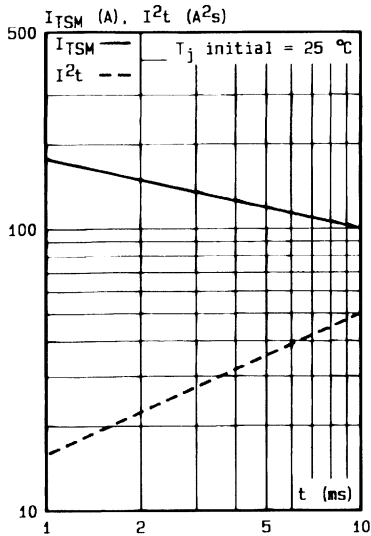

Fig.7 - Non repetitive surge peak on-state current for a sinusoidal pulse with width :  $t \leq 10$  ms, and corresponding value of  $I^2t$ .

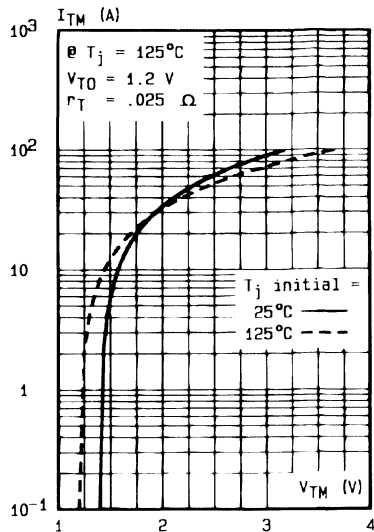
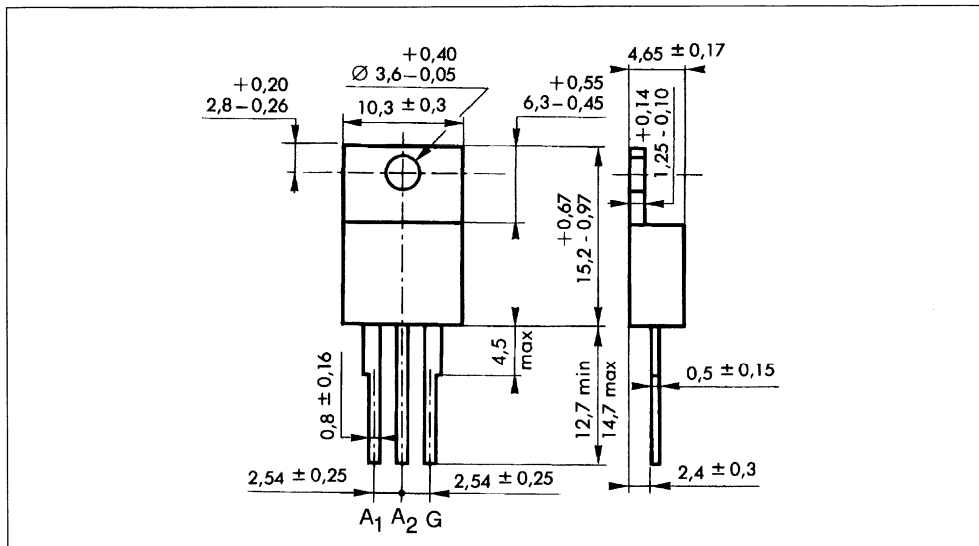

Fig.8 - On-state characteristics (maximum values).

**PACKAGE MECHANICAL DATA**

TO 220 AB (CB-415) Plastic



Cooling method : by conduction (method C)  
 Marking : type number  
 Weight : 2 g



**SNUBBERLESS TRIACS**

- $I_{TRMS} = 10$  A at  $T_c = 100$  °C.
- $V_{DRM} : 200$  V to  $800$  V.
- $I_{GT} = 35$  mA (QI-II-III).
- GLASS PASSIVATED CHIP.
- HIGH SURGE CURRENT :  $I_{TSM} = 100$  A.
- HIGH COMMUTATION CAPABILITY :  
 $(di/dt)_c > 5.5$  A / ms without snubber.

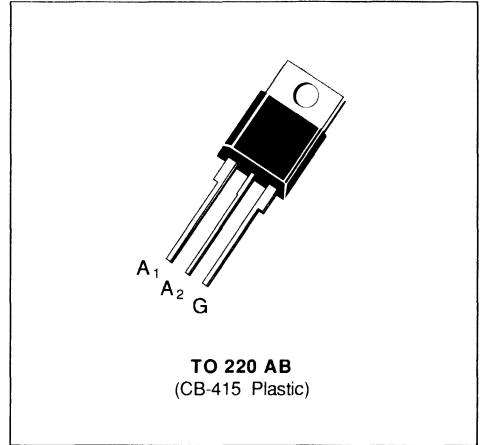
**DESCRIPTION**

New range suited for applications such as phase control and static switching on inductive or resistive load.

**ABSOLUTE RATINGS** (limiting values)

Symbol	Parameter		Value	Unit
$I_{TRMS}$	RMS on-state current (360 ° conduction angle)	$T_c = 100$ °C	10	A
$I_{TSM}$	Non repetitive surge peak on-state current ( $T_j$ initial = 25 °C)	$t = 8.3$ ms	105	A
		$t = 10$ ms	100	
$I^2t$	$I^2t$ value	$t = 10$ ms	50	A <sup>2</sup> s
$di/dt$	Critical rate of rise of on-state current (1)	Repetitive F = 50 Hz	20	A/μs
		Non Repetitive	100	
$T_{stg}$ $T_j$	Storage and operating junction temperature range		- 40, + 150	°C
			- 40, + 125	°C

Symbol	Parameter	BTB 10-					Unit
		200 CW	400 CW	600 CW	700 CW	800 CW	
$V_{DRM}$	Repetitive peak off-state voltage (2)	± 200	± 400	± 600	± 700	± 800	V

(1) Gate supply :  $I_G = 350$  mA -  $di_G/dt = 1$  A / μs.

(2)  $T_j = 125$  °C.

**THERMAL RESISTANCES**

Symbol	Parameter	Value	Unit
$R_{th(j-a)}$	Junction to ambient	60	°C/W
$R_{th(j-c)DC}$	Junction to case for DC	2.7	°C/W
$R_{th(j-c)AC}$	Junction to case for 360° conduction angle (F = 50 Hz)	2	°C/W

**GATE CHARACTERISTICS (maximum values)**
 $P_{GM} = 40 \text{ W (} t = 10 \mu\text{s)}$     $P_{G(AV)} = 1 \text{ W}$     $I_{GM} = 4 \text{ A (} t = 10 \mu\text{s)}$     $V_{GM} = 16 \text{ V (} t = 10 \mu\text{s)}$ .

**ELECTRICAL CHARACTERISTICS**

Symbol	Test Conditions		Quadrants	Min.	Typ.	Max.	Unit
$I_{GT}$	$T_j = 25 \text{ °C}$ Pulse duration > 20 $\mu\text{s}$	$V_D = 12 \text{ V}$ $R_L = 33 \Omega$	I-II-III	1		35	mA
$V_{GT}$	$T_j = 25 \text{ °C}$ Pulse duration > 20 $\mu\text{s}$	$V_D = 12 \text{ V}$ $R_L = 33 \Omega$	I-II-III			1.5	V
$V_{GD}$	$T_j = 125 \text{ °C}$ Pulse duration > 20 $\mu\text{s}$	$V_D = V_{DRM}$ $R_L = 3.3 \text{ k}\Omega$	I-II-III	0.2			V
$I_H^*$	$T_j = 25 \text{ °C}$ Gate open	$I_T = 100 \text{ mA}$ $R_L = 140 \Omega$				35	mA
$I_L$	$T_j = 25 \text{ °C}$ Pulse duration > 20 $\mu\text{s}$	$V_D = 12 \text{ V}$ $I_G = 350 \text{ mA}$	I-III			50	mA
			II			80	
$V_{TM}^*$	$T_j = 25 \text{ °C}$	$I_{TM} = 14 \text{ A}$ $t_p = 10 \text{ ms}$				1.65	V
$I_{DRM}^*$	$T_j = 25 \text{ °C}$	$V_{DRM}$ rated Gate open				0.01	mA
	$T_j = 125 \text{ °C}$					2	
$dv/dt^*$	$T_j = 125 \text{ °C}$ Linear slope up to 0.67 $V_{DRM}$	Gate open		250	500		V/ $\mu\text{s}$
$(di/dt)_c^*$	$T_j = 125 \text{ °C}$ Without snubber	$V_{DRM}$ rated		5.5	11		A/ms
$t_{gt}$	$T_j = 25 \text{ °C}$ $I_T = 14 \text{ A}$	$di_G/dt = 1 \text{ A}/\mu\text{s}$ $V_D = V_{DRM}$	I-II-III		2		$\mu\text{s}$

\* For either polarity of electrode A<sub>2</sub> voltage with reference to electrode A<sub>1</sub>.

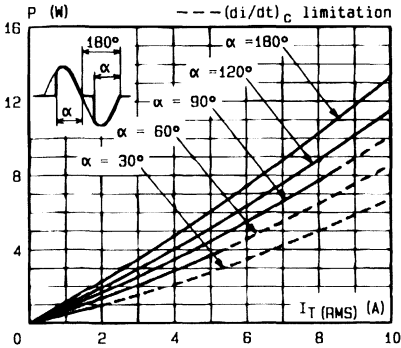

Fig. 1 - Maximum mean power dissipation versus RMS on-state current ( $f = 60 \text{ Hz}$ ).

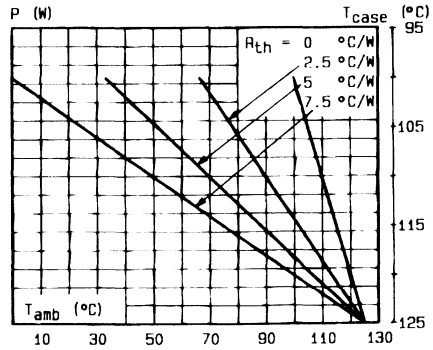

Fig. 2 - Correlation between maximum mean power dissipation and maximum allowable temperatures ( $T_{amb}$  and  $T_{case}$ ) for different thermal resistances heatsink + contact.

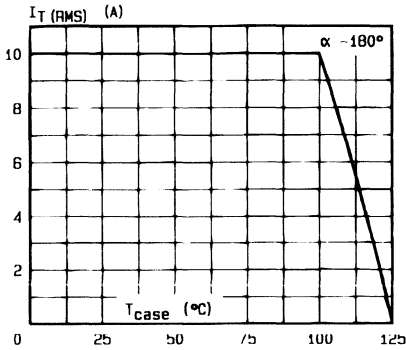

Fig. 3 - RMS on-state current versus case temperature.

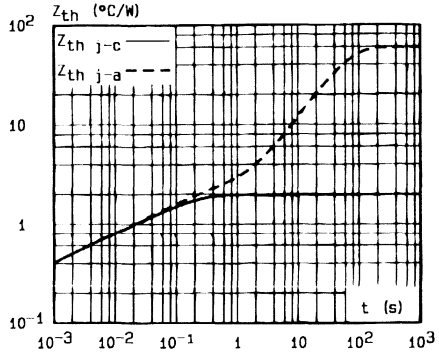

Fig. 4 - Thermal transient impedance junction to case and junction to ambient versus pulse duration.

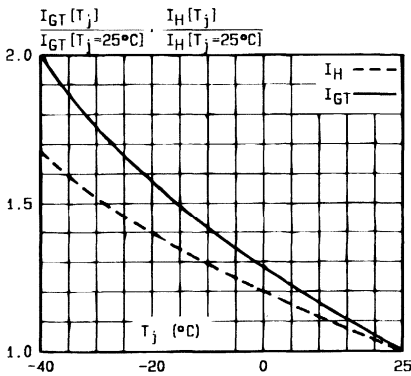

Fig. 5 - Relative variation of gate trigger current and holding current versus junction temperature.

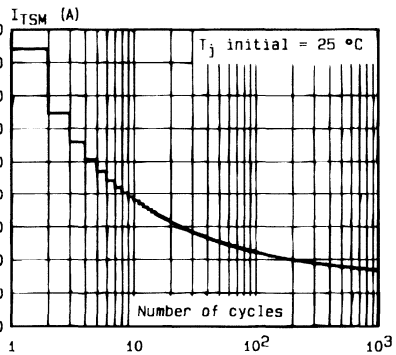

Fig. 6 - Non repetitive surge peak on-state current versus number of cycles.

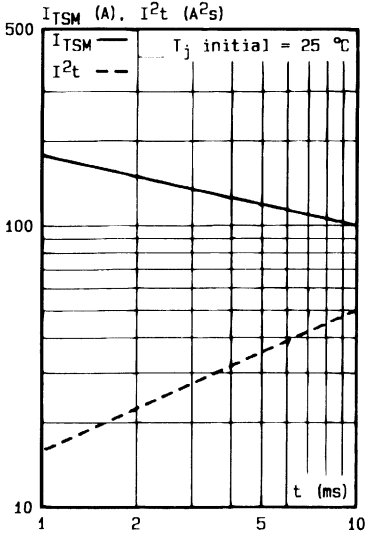

Fig.7 - Non repetitive surge peak on-state current for a sinusoidal pulse with width :  $t \leq 10$  ms, and corresponding value of  $I^2t$ .

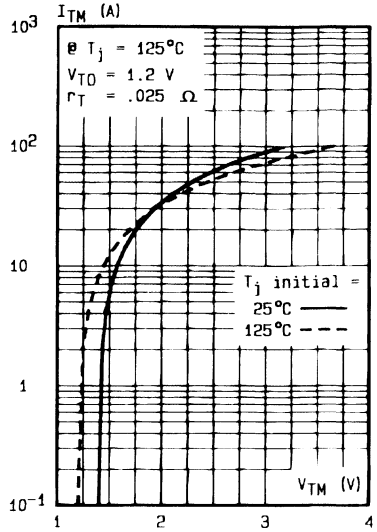
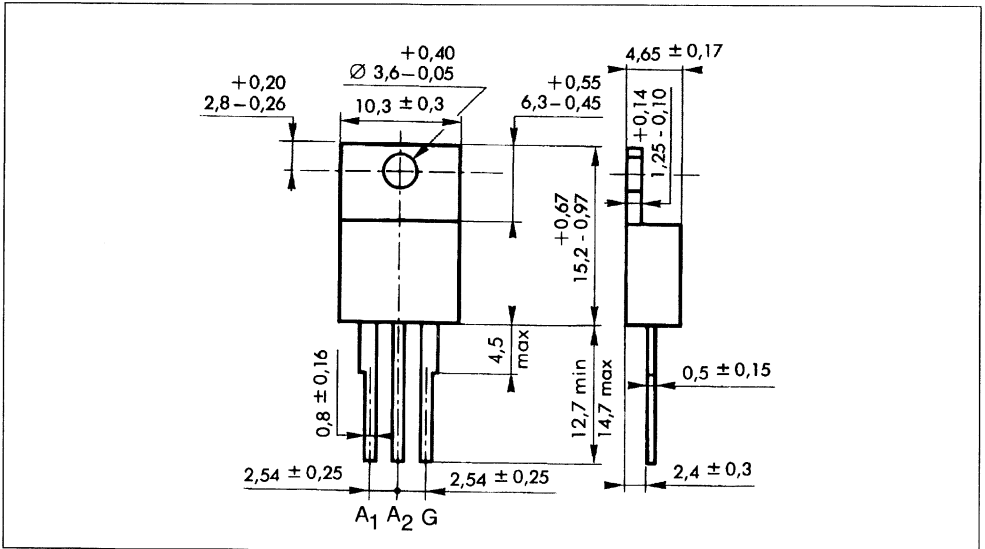

Fig.8 - On-state characteristics (maximum values).

**PACKAGE MECHANICAL DATA**

TO 220 AB (CB-415) Plastic



Cooling method : by conduction (method C)  
 Marking : type number  
 Weight : 2 g

**SNUBBERLESS TRIACS**

- $I_{TRMS} = 12\text{ A}$  at  $T_c = 95\text{ }^\circ\text{C}$ .
- $V_{DRM} : 200\text{ V to } 800\text{ V}$ .
- $I_{GT} = 75\text{ mA}$  (QI-II-III).
- GLASS PASSIVATED CHIP.
- HIGH SURGE CURRENT :  $I_{TSM} = 120\text{ A}$ .
- HIGH COMMUTATION CAPABILITY :  
 $(di/dt)_c > 16\text{ A/ms}$  without snubber.

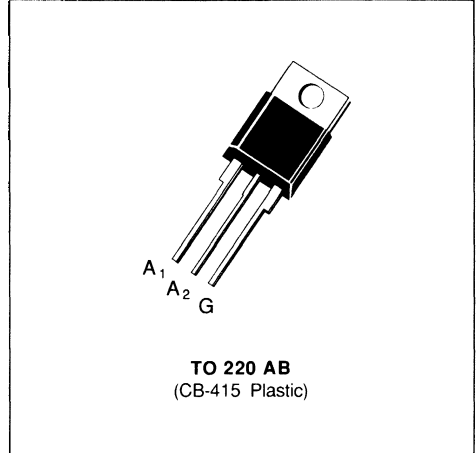
**DESCRIPTION**

New range suited for applications such as phase control and static switching on inductive or resistive load.

**ABSOLUTE RATINGS** (limiting values)

Symbol	Parameter	Value	Unit
$I_{TRMS}$	RMS on-state current (360 ° conduction angle)	$T_c = 95\text{ }^\circ\text{C}$ 12	A
$I_{TSM}$	Non repetitive surge peak on-state current ( $T_j$ initial = 25 °C)	$t = 8.3\text{ ms}$	126
		$t = 10\text{ ms}$	120
$I^2t$	$I^2t$ value	$t = 10\text{ ms}$	72
$di/dt$	Critical rate of rise of on-state current (1)	Repetitive F = 50 Hz	20
		Non Repetitive	100
$T_{stg}$ $T_j$	Storage and operating junction temperature range	- 40, + 150 - 40, + 125	$^\circ\text{C}$ $^\circ\text{C}$

Symbol	Parameter	BTB 12-					Unit
		200 AW	400 AW	600 AW	700 AW	800 AW	
$V_{DRM}$	Repetitive peak off-state voltage (2)	$\pm 200$	$\pm 400$	$\pm 600$	$\pm 700$	$\pm 800$	V

(1) Gate supply :  $I_G = 750\text{ mA}$  –  $di_G/dt = 1\text{ A}/\mu\text{s}$ .

(2)  $T_j = 125\text{ }^\circ\text{C}$ .

**THERMAL RESISTANCES**

Symbol	Parameter	Value	Unit
$R_{th(j-a)}$	Junction to ambient	60	°C/W
$R_{th(j-c)DC}$	Junction to case for DC	2.7	°C/W
$R_{th(j-c)AC}$	Junction to case for 360° conduction angle (F = 50 Hz)	2	°C/W

**GATE CHARACTERISTICS (maximum values)**
 $P_{GM} = 40 \text{ W (} t = 10 \mu\text{s)}$     $P_{G(AV)} = 1 \text{ W}$     $I_{GM} = 4 \text{ A (} t = 10 \mu\text{s)}$     $V_{GM} = 16 \text{ V (} t = 10 \mu\text{s)}$ 
**ELECTRICAL CHARACTERISTICS**

Symbol	Test Conditions	Quadrants	Min.	Typ.	Max.	Unit
$I_{GT}$	$T_j = 25 \text{ °C}$ $V_D = 12 \text{ V}$ $R_L = 33 \Omega$ Pulse duration > 20 $\mu\text{s}$	I-II-III	2		75	mA
$V_{GT}$	$T_j = 25 \text{ °C}$ $V_D = 12 \text{ V}$ $R_L = 33 \Omega$ Pulse duration > 20 $\mu\text{s}$	I-II-III			1.5	V
$V_{GD}$	$T_j = 125 \text{ °C}$ $V_D = V_{DRM}$ $R_L = 3.3 \text{ k}\Omega$ Pulse duration > 20 $\mu\text{s}$	I-II-III	0.2			V
$I_H^*$	$T_j = 25 \text{ °C}$ $I_T = 100 \text{ mA}$ Gate open $R_L = 140 \Omega$				75	mA
$I_L$	$T_j = 25 \text{ °C}$ $V_D = 12 \text{ V}$ Pulse duration > 20 $\mu\text{s}$	I-III		75		mA
		II		150		
$V_{TM}^*$	$T_j = 25 \text{ °C}$ $I_{TM} = 17 \text{ A}$ $t_p = 10 \text{ ms}$				1.6	V
$I_{DRM}^*$	$T_j = 25 \text{ °C}$ $T_j = 125 \text{ °C}$	$V_{DRM}$ rated Gate open			0.01	mA
					2	
$dv/dt^*$	$T_j = 125 \text{ °C}$ Gate open Linear slope up to 0.67 $V_{DRM}$		750	1000		V/ $\mu\text{s}$
$(di/dt)_c^*$	$T_j = 125 \text{ °C}$ $V_{DRM}$ rated Without snubber		16	32		A/ms
$t_{gt}$	$T_j = 25 \text{ °C}$ $di_G/dt = 3.5 \text{ A}/\mu\text{s}$ $I_G = 500 \text{ mA}$ $I_T = 17 \text{ A}$ $V_D = V_{DRM}$	I-II-III		2		$\mu\text{s}$

\* For either polarity of electrode A<sub>2</sub> voltage with reference to electrode A<sub>1</sub>.

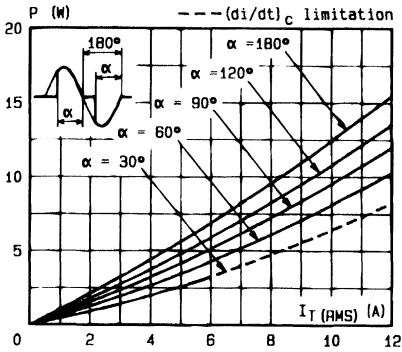

Fig. 1 - Maximum mean power dissipation versus RMS on-state current (F = 60 Hz).

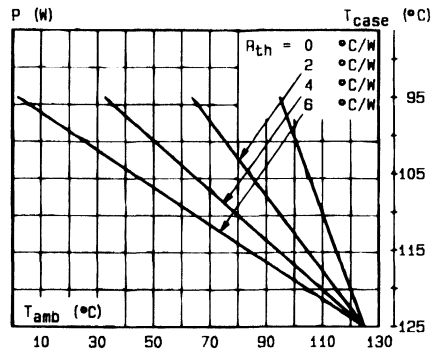

Fig. 2 - Correlation between maximum mean power dissipation and maximum allowable temperatures (T<sub>amb</sub> and T<sub>case</sub>) for different thermal resistances (R<sub>th</sub> = heatsink + contact).

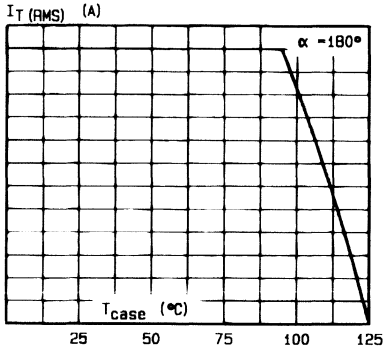

Fig. 3 - RMS on-state current versus case temperature.

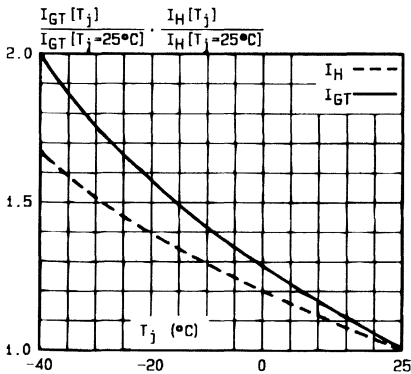

Fig. 5 - Relative variation of gate trigger current and holding current versus junction temperature.

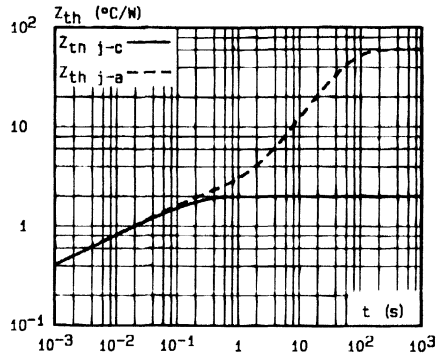

Fig. 4 - Thermal transient impedance junction to case and junction to ambient versus pulse duration.

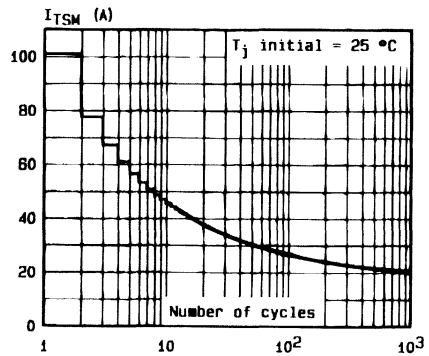

Fig. 6 - Non repetitive surge peak on-state current versus number of cycles.

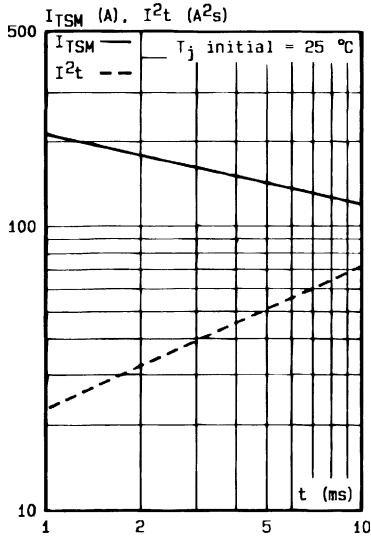

Fig.7 - Non repetitive surge peak on-state current for a sinusoidal pulse with width :  $t \leq 10$  ms, and corresponding value of  $I^2t$ .

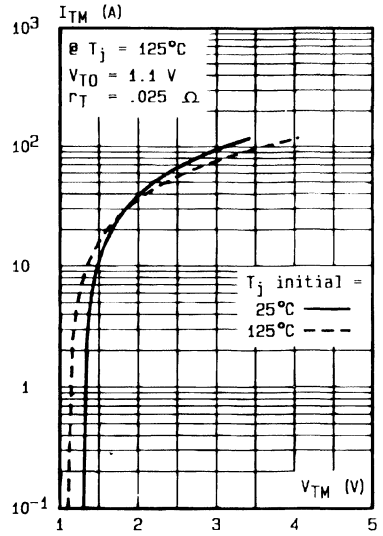
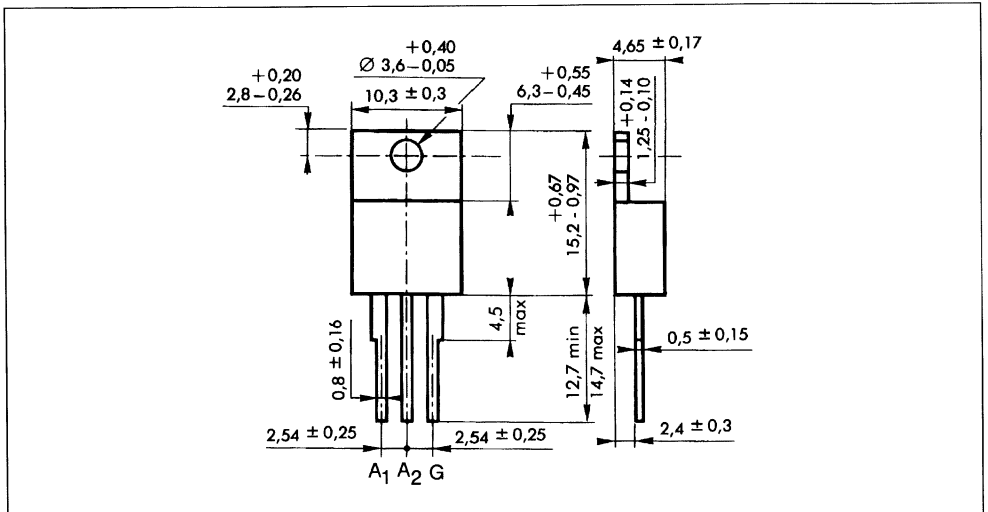

Fig.8 - On-state characteristics (maximum values).

PACKAGE MECHANICAL DATA

TO 220 AB (CB-415) Plastic



Cooling method : by conduction (method C)

Marking : type number

Weight : 2 g



**SNUBBERLESS TRIACS**

- $I_{TRMS} = 12\text{ A}$  at  $T_c = 95\text{ }^\circ\text{C}$ .
- $V_{DRM} : 200\text{ V to } 800\text{ V}$ .
- $I_{GT} = 50\text{ mA}$  (QI-II-III).
- GLASS PASSIVATED CHIP.
- HIGH SURGE CURRENT :  $I_{TSM} = 120\text{ A}$ .
- HIGH COMMUTATION CAPABILITY :  
 $(di/dt)_c > 12\text{ A / ms}$  without snubber.

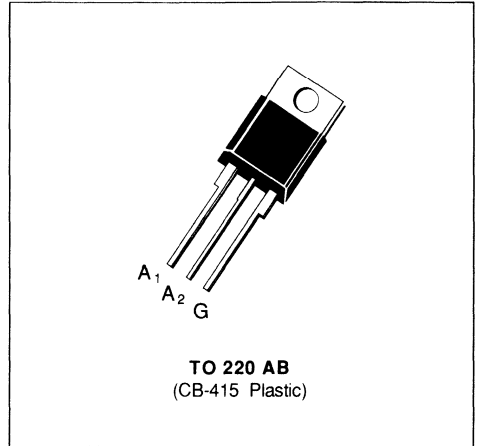
**DESCRIPTION**

New range suited for applications such as phase control and static switching on inductive or resistive load.

**ABSOLUTE RATINGS** (limiting values)

Symbol	Parameter		Value	Unit
$I_{TRMS}$	RMS on-state current (360 ° conduction angle)	$T_c = 95\text{ }^\circ\text{C}$	12	A
$I_{TSM}$	Non repetitive surge peak on-state current ( $T_j$ initial = 25 °C)	$t = 8.3\text{ ms}$	126	A
		$t = 10\text{ ms}$	120	
$I^2t$	$I^2t$ value	$t = 10\text{ ms}$	72	$\text{A}^2\text{s}$
$di/dt$	Critical rate of rise of on-state current (1)	Repetitive $F = 50\text{ Hz}$	20	A / $\mu\text{s}$
		Non Repetitive	100	
$T_{stg}$ $T_j$	Storage and operating junction temperature range		- 40, + 150 - 40, + 125	$^\circ\text{C}$ $^\circ\text{C}$

Symbol	Parameter	BTB 12-					Unit
		200 BW	400 BW	600 BW	700 BW	800 BW	
$V_{DRM}$	Repetitive peak off-state voltage (2)	$\pm 200$	$\pm 400$	$\pm 600$	$\pm 700$	$\pm 800$	V

(1) Gate supply :  $I_G = 50\text{ mA}$  –  $di_G/dt = 1\text{ A / } \mu\text{s}$ .

(2)  $T_j = 125\text{ }^\circ\text{C}$ .

**THERMAL RESISTANCES**

Symbol	Parameter	Value	Unit
$R_{th(j-a)}$	Junction to ambient	60	°C/W
$R_{th(j-c)DC}$	Junction to case for DC	2.7	°C/W
$R_{th(j-c)AC}$	Junction to case for 360° conduction angle (F = 50 Hz)	2	°C/W

**GATE CHARACTERISTICS (maximum values)**
 $P_{GM} = 40 \text{ W (} t = 10 \mu\text{s)}$      $P_{G(AV)} = 1 \text{ W}$      $I_{GM} = 4 \text{ A (} t = 10 \mu\text{s)}$      $V_{GM} = 16 \text{ V (} t = 10 \mu\text{s)}$ .

**ELECTRICAL CHARACTERISTICS**

Symbol	Test Conditions			Quadrants	Min.	Typ.	Max.	Unit
$I_{GT}$	$T_j = 25 \text{ °C}$	$V_D = 12 \text{ V}$	$R_L = 33 \Omega$	I-II-III	2		50	mA
	Pulse duration > 20 $\mu\text{s}$							
$V_{GT}$	$T_j = 25 \text{ °C}$	$V_D = 12 \text{ V}$	$R_L = 33 \Omega$	I-II-III			1.5	V
	Pulse duration > 20 $\mu\text{s}$							
$V_{GD}$	$T_j = 125 \text{ °C}$	$V_D = V_{DRM}$	$R_L = 3.3 \text{ k}\Omega$	I-II-III	0.2			V
	Pulse duration > 20 $\mu\text{s}$							
$I_{H^*}$	$T_j = 25 \text{ °C}$	$I_T = 100 \text{ mA}$					50	mA
	Gate open $R_L = 140 \Omega$							
$I_L$	$T_j = 25 \text{ °C}$	$V_D = 12 \text{ V}$	$I_G = 500 \text{ mA}$	I-III		50		mA
				II		100		
	Pulse duration > 20 $\mu\text{s}$							
$V_{TM^*}$	$T_j = 25 \text{ °C}$	$I_{TM} = 17 \text{ A}$	$t_p = 10 \text{ ms}$				1.6	V
$I_{DRM^*}$	$T_j = 25 \text{ °C}$	$V_{DRM}$ rated	Gate open				0.01	mA
	$T_j = 125 \text{ °C}$						2	
$dv/dt^*$	$T_j = 125 \text{ °C}$	Gate open Linear slope up to 0.67 $V_{DRM}$			500	750		V/ $\mu\text{s}$
$(di/dt)_c^*$	$T_j = 125 \text{ °C}$	$V_{DRM}$ rated Without snubber			12	24		A/ms
$t_{gt}$	$T_j = 25 \text{ °C}$	$di_G/dt = 3.5 \text{ A}/\mu\text{s}$	$I_G = 500 \text{ mA}$	I-II-III		2		$\mu\text{s}$
	$I_T = 17 \text{ A}$	$V_D = V_{DRM}$						

\* For either polarity of electrode A<sub>2</sub> voltage with reference to electrode A<sub>1</sub>.

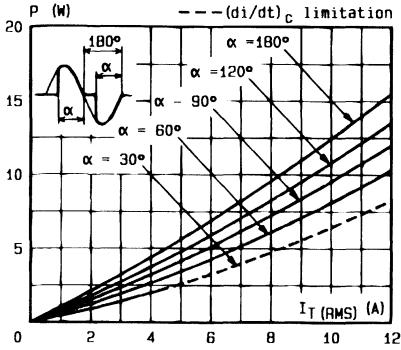

Fig. 1 - Maximum mean power dissipation versus RMS on-state current (F = 60 Hz).

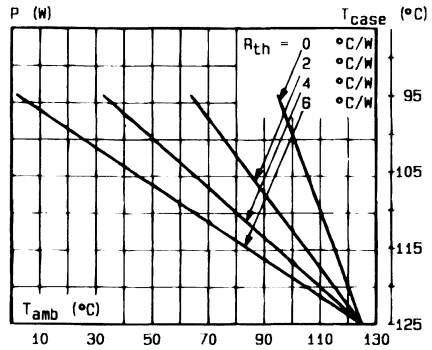

Fig. 2 - Correlation between maximum mean power dissipation and maximum allowable temperatures ( $T_{amb}$  and  $T_{case}$ ) for different thermal resistances heatsink + contact.

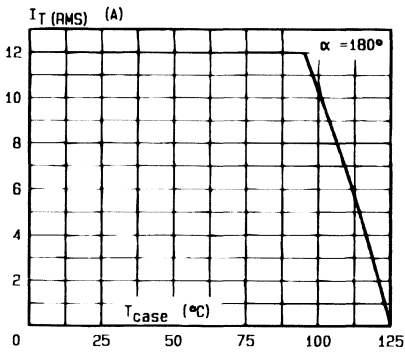

Fig. 3 - RMS on-state current versus case temperature.

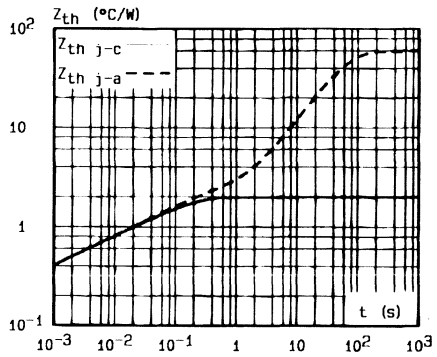

Fig. 4 - Thermal transient impedance junction to case and junction to ambient versus pulse duration.

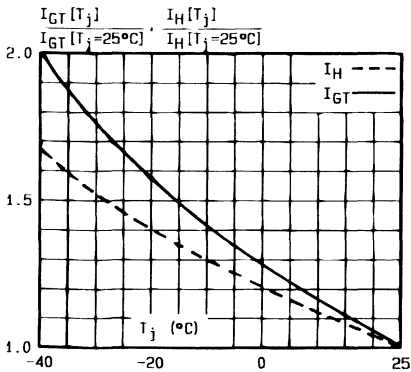

Fig. 5 - Relative variation of gate trigger current and holding current versus junction temperature.

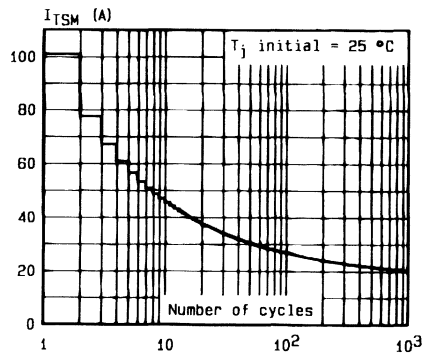

Fig. 6 - Non repetitive surge peak on-state current versus number of cycles.

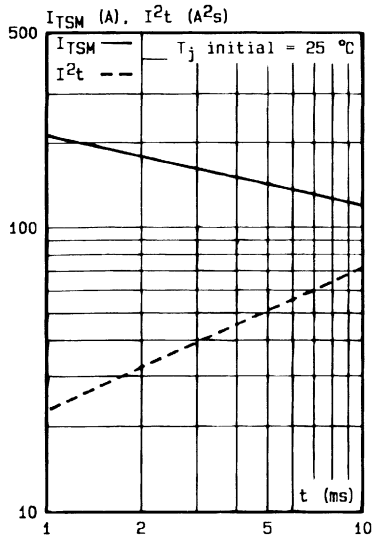

Fig.7 - Non repetitive surge peak on-state current for a sinusoidal pulse with width :  $t \leq 10 \text{ ms}$ , and corresponding value of  $I^2t$ .

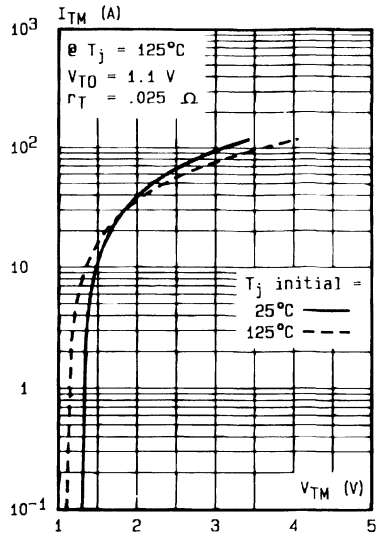
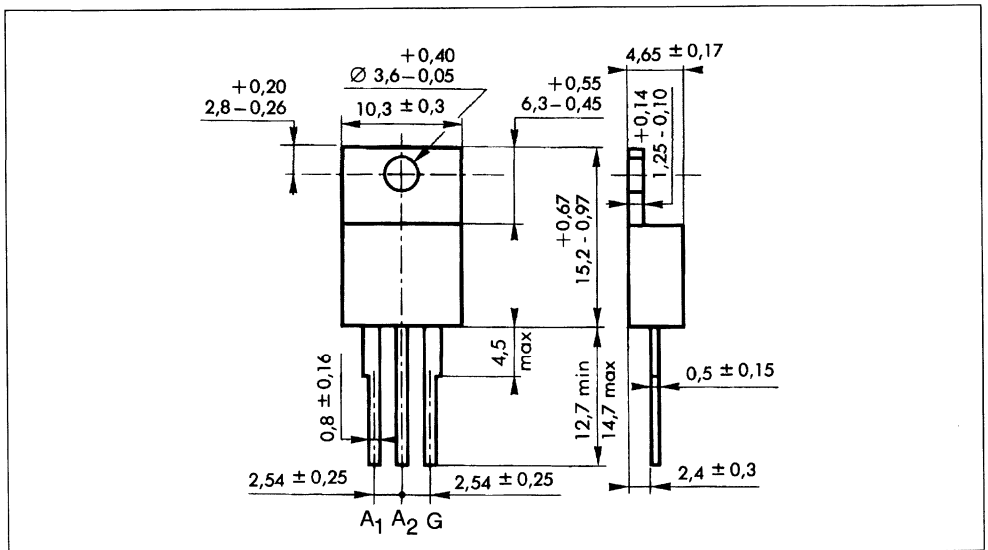

Fig.8 - On-state characteristics (maximum values).

PACKAGE MECHANICAL DATA

TO 220 AB (CB-415) Plastic



Cooling method : by conduction (method C)  
 Marking : type number  
 Weight : 2 g

**SNUBBERLESS TRIACS**

- $I_{TRMS} = 12\text{ A}$  at  $T_c = 95\text{ }^\circ\text{C}$ .
- $V_{DRM} : 200\text{ V}$  to  $800\text{ V}$ .
- $I_{GT} = 35\text{ mA}$  (QI-II-III).
- GLASS PASSIVATED CHIP.
- HIGH SURGE CURRENT :  $I_{TSM} = 120\text{ A}$ .
- HIGH COMMUTATION CAPABILITY :  
 $(di/dt)_c > 6.5\text{ A/ms}$  without snubber.

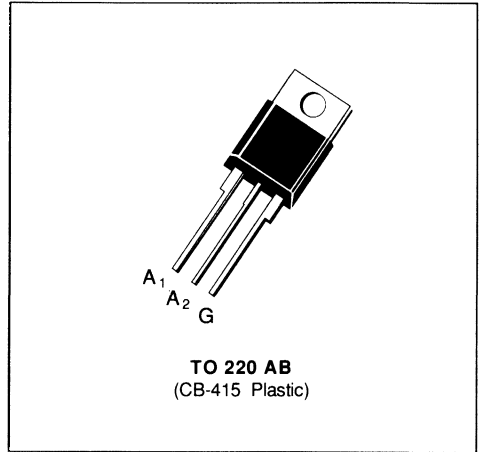
**DESCRIPTION**

New range suited for applications such as phase control and static switching on inductive or resistive load.

**ABSOLUTE RATINGS** (limiting values)

Symbol	Parameter		Value	Unit
$I_{TRMS}$	RMS on-state current (360 ° conduction angle)	$T_c = 95\text{ }^\circ\text{C}$	12	A
$I_{TSM}$	Non repetitive surge peak on-state current ( $T_j$ initial = $25\text{ }^\circ\text{C}$ )	$t = 8.3\text{ ms}$	126	A
		$t = 10\text{ ms}$	120	
$I^2t$	$I^2t$ value	$t = 10\text{ ms}$	72	$\text{A}^2\text{s}$
$di/dt$	Critical rate of rise of on-state current (1)	Repetitive $F = 50\text{ Hz}$	20	A/ $\mu\text{s}$
		Non Repetitive	100	
$T_{stg}$ $T_j$	Storage and operating junction temperature range		- 40, + 150 - 40, + 125	$^\circ\text{C}$ $^\circ\text{C}$

Symbol	Parameter	BTB 12-					Unit
		200 CW	400 CW	600 CW	700 CW	800 CW	
$V_{DRM}$	Repetitive peak off-state voltage (2)	$\pm 200$	$\pm 400$	$\pm 600$	$\pm 700$	$\pm 800$	V

(1) Gate supply :  $I_G = 350\text{ mA}$  –  $di_G/dt = 1\text{ A}/\mu\text{s}$ .

(2)  $T_j = 125\text{ }^\circ\text{C}$ .

**THERMAL RESISTANCES**

Symbol	Parameter	Value	Unit
$R_{th(j-a)}$	Junction to ambient	60	°C/W
$R_{th(j-c)DC}$	Junction to case for DC	2.7	°C/W
$R_{th(j-c)AC}$	Junction to case for 360° conduction angle (F = 50 Hz)	2	°C/W

**GATE CHARACTERISTICS (maximum values)**
 $P_{GM} = 40 \text{ W}$  (t = 10  $\mu\text{s}$ )     $P_{G(AV)} = 1 \text{ W}$      $I_{GM} = 4 \text{ A}$  (t = 10  $\mu\text{s}$ )     $V_{GM} = 16 \text{ V}$  (t = 10  $\mu\text{s}$ ).

**ELECTRICAL CHARACTERISTICS**

Symbol	Test Conditions		Quadrants	Min.	Typ.	Max.	Unit
$I_{GT}$	$T_j = 25 \text{ }^\circ\text{C}$ Pulse duration > 20 $\mu\text{s}$	$V_D = 12 \text{ V}$ $R_L = 33 \text{ } \Omega$	I-II-III	1		35	mA
$V_{GT}$	$T_j = 25 \text{ }^\circ\text{C}$ Pulse duration > 20 $\mu\text{s}$	$V_D = 12 \text{ V}$ $R_L = 33 \text{ } \Omega$	I-II-III			1.5	V
$V_{GD}$	$T_j = 125 \text{ }^\circ\text{C}$ Pulse duration > 20 $\mu\text{s}$	$V_D = V_{DRM}$ $R_L = 3.3 \text{ k}\Omega$	I-II-III	0.2			V
$I_H^*$	$T_j = 25 \text{ }^\circ\text{C}$ Gate open	$I_T = 100 \text{ mA}$ $R_L = 140 \text{ } \Omega$				35	mA
$I_L$	$T_j = 25 \text{ }^\circ\text{C}$ Pulse duration > 20 $\mu\text{s}$	$V_D = 12 \text{ V}$ $I_G = 350 \text{ mA}$	I-III			50	mA
			II			80	
$V_{TM}^*$	$T_j = 25 \text{ }^\circ\text{C}$	$I_{TM} = 17 \text{ A}$ $t_p = 10 \text{ ms}$				1.6	V
$I_{DRM}^*$	$T_j = 25 \text{ }^\circ\text{C}$	$V_{DRM}$ rated Gate open				0.01	mA
	$T_j = 125 \text{ }^\circ\text{C}$					2	
$dv/dt^*$	$T_j = 125 \text{ }^\circ\text{C}$ Linear slope up to 0.67 $V_{DRM}$	Gate open		250	500		V/ $\mu\text{s}$
$(di/dt)_c^*$	$T_j = 125 \text{ }^\circ\text{C}$ Without snubber	$V_{DRM}$ rated		6.5	13		A/ms
$t_{gt}$	$T_j = 25 \text{ }^\circ\text{C}$ $I_T = 17 \text{ A}$	$di_G/dt = 1 \text{ A}/\mu\text{s}$ $V_D = V_{DRM}$	$I_G = 350 \text{ mA}$ I-II-III		2		$\mu\text{s}$

\* For either polarity of electrode  $A_2$  voltage with reference to electrode  $A_1$ .

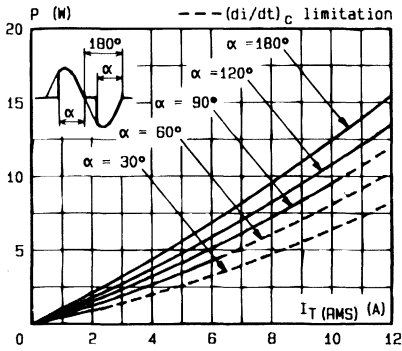

Fig. 1 - Maximum mean power dissipation versus RMS on-state current (f = 60 Hz).

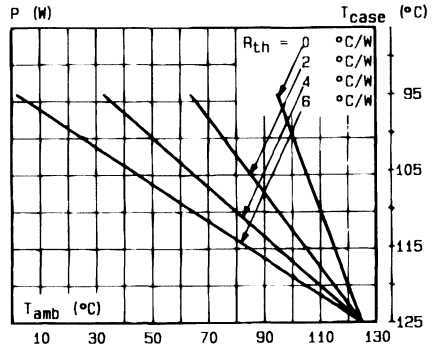

Fig. 2 - Correlation between maximum mean power dissipation and maximum allowable temperatures (T<sub>amb</sub> and T<sub>case</sub>) for different thermal resistances (heatsink + contact).

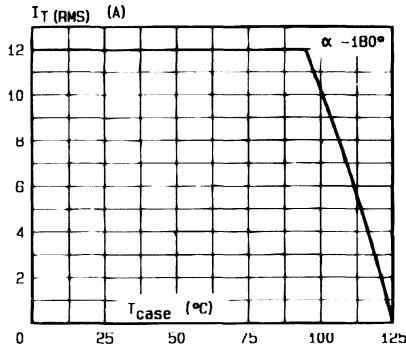

Fig. 3 - RMS on-state current versus case temperature.

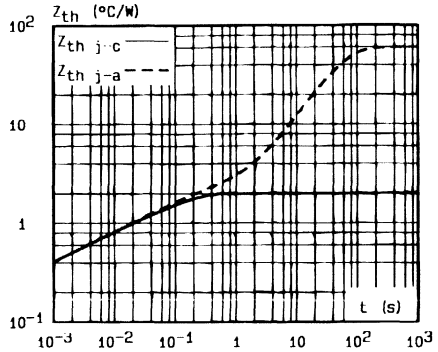

Fig. 4 - Thermal transient impedance junction to case and junction to ambient versus pulse duration.

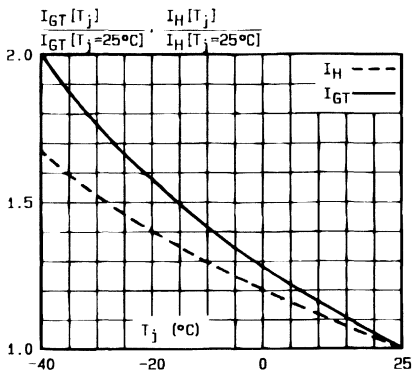

Fig. 5 - Relative variation of gate trigger current and holding current versus junction temperature.

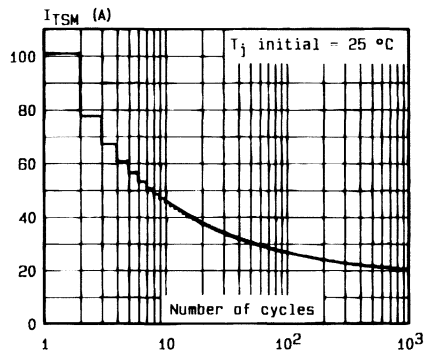

Fig. 6 - Non repetitive surge peak on-state current versus number of cycles.

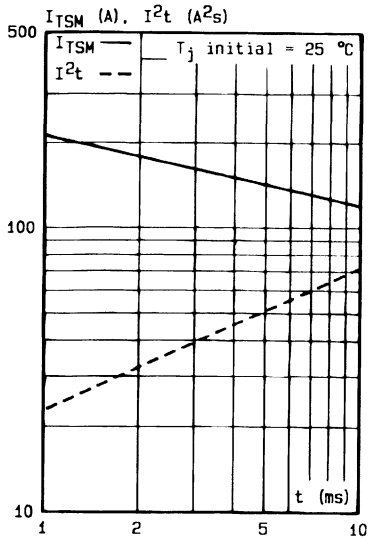

Fig.7 - Non repetitive surge peak on-state current for a sinusoidal pulse with width :  $t \leq 10$  ms, and corresponding value of  $I^2t$ .

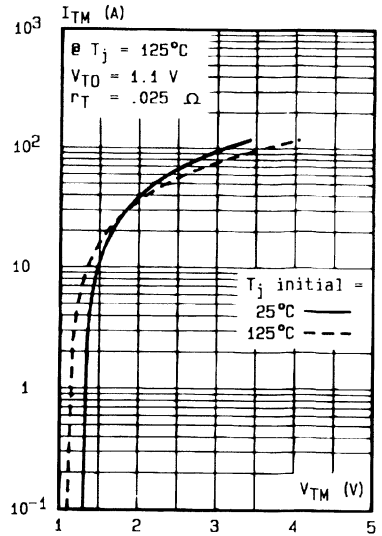
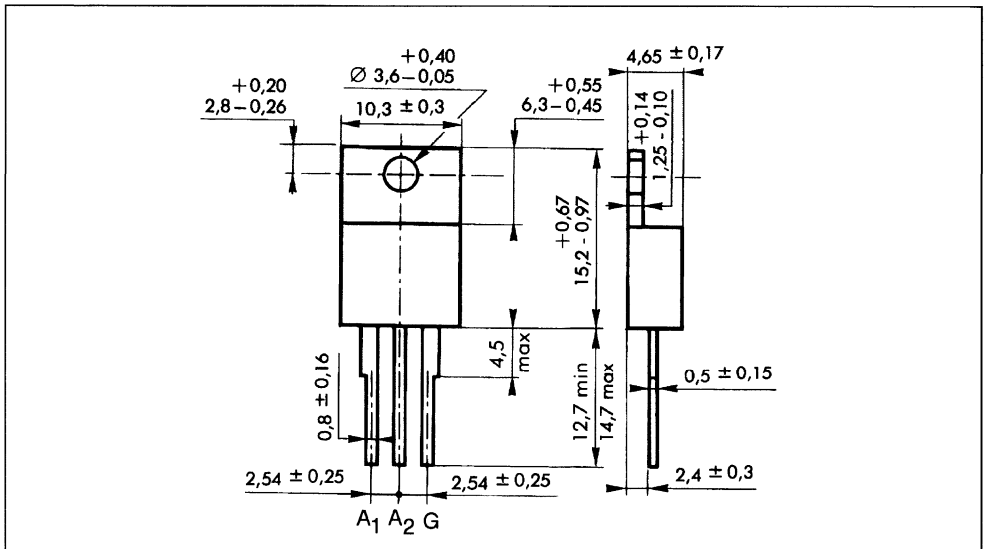

Fig.8 - On-state characteristics (maximum values).

**PACKAGE MECHANICAL DATA**

TO 220 AB (CB-415) Plastic



Cooling method : by conduction (method C)  
 Marking : type number  
 Weight : 2 g



**TRIACS**

- GLASS PASSIVATED CHIP
- HIGH CAPACITOR DISCHARGE CURRENT

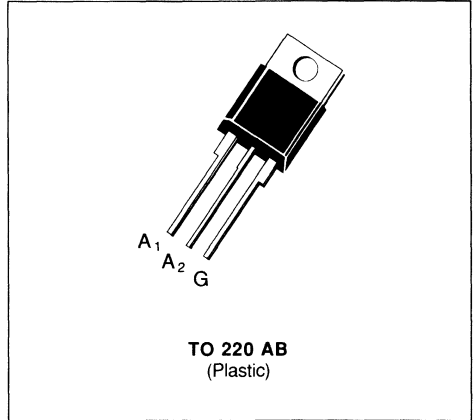
**DESCRIPTION**

Design primarily for applications such as phase control, static switching, power supply

**ABSOLUTE RATINGS** (limiting values)

Symbol	Parameter	Value	Unit
$I_{T(RMS)}$	RMS on-state Current (360° conduction angle)	$T_C = 100\text{ }^\circ\text{C}$ 12	A
$I_{TSM}$	Non Repetitive Surge Peak on-state Current ( $T_J$ initial = 25 °C - Half sine wave)	$t = 8.3\text{ ms}$	157
		$t = 10\text{ ms}$	150
$I^2t$	$I^2t$ Value for Fusing	$t = 10\text{ ms}$ 112.5	A <sup>2</sup> s
di/dt	Critical Rate of Rise of on-state Current (1)	Repetitive F = 50 Hz	20
		Non Repetitive	100
$T_{stg}$ $T_J$	Storage and Operating Junction Temperature Range	- 40 to 150	°C
		- 40 to 125	°C

Symbol	Parameter	BTB 13-					Unit
		200B	400B	600B	700B	800B	
$V_{DRM}$	Repetitive Peak off-state Voltage (2)	200	400	600	700	800	V

(1)  $I_G = 750\text{ mA}$      $di_G/dt = 1\text{ A}/\mu\text{s}$

(2)  $T_J = 125\text{ }^\circ\text{C}$ .

**THERMAL RESISTANCES**

Symbol	Parameter	Value	Unit
$R_{th(j-a)}$	Junction to Ambient	60	°C/W
$R_{th(j-c)}\text{ DC}$	Junction to Case for DC	2.4	°C/W
$R_{th(j-c)}\text{ AC}$	Junction to Case for 360° Conduction Angle (F = 50 Hz)	1.8	°C/W

**GATE CHARACTERISTICS (maximum values)**

$P_{GM} = 40 \text{ W}$  ( $t_p = 10 \mu\text{s}$ )       $I_{GM} = 4 \text{ A}$  ( $t_p = 10 \mu\text{s}$ )  
 $P_{G(AV)} = 1 \text{ W}$        $V_{GM} = 16 \text{ V}$  ( $t_p = 10 \mu\text{s}$ )

**ELECTRICAL CHARACTERISTICS**

Symbol	Test Conditions			Quadrants	Min.	Typ.	Max.	Unit
$I_{GT}$	$T_j = 25 \text{ }^\circ\text{C}$ Pulse Duration > 20 $\mu\text{s}$	$V_D = 12 \text{ V}$	$R_L = 33 \text{ } \Omega$	I-II-III			50	mA
				IV			75	
$V_{GT}$	$T_j = 25 \text{ }^\circ\text{C}$ Pulse Duration > 20 $\mu\text{s}$	$V_D = 12 \text{ V}$	$R_L = 33 \text{ } \Omega$	I-II-III-IV			1.5	V
$V_{GD}$	$T_j = 125 \text{ }^\circ\text{C}$	$V_D = V_{DRM}$	$R_L = 3.3 \text{ k}\Omega$	I-II-III-IV	0.2			V
$I_H^*$	$T_j = 25 \text{ }^\circ\text{C}$	$I_T = 100 \text{ mA}$	Gate Open				50	mA
$I_L$	$T_j = 25 \text{ }^\circ\text{C}$ Pulse Duration > 20 $\mu\text{s}$	$V_D = 12 \text{ V}$	$I_G = 150 \text{ mA}$	I-III-IV		50		mA
				II		100		
$V_{TM}^*$	$T_j = 25 \text{ }^\circ\text{C}$	$I_{TM} = 17 \text{ A}$	$t_p = 10 \text{ ms}$				1.4	V
$I_{DRM}^*$	$V_{DRM}$ Specified						0.01	mA
							2	
$dv/dt^*$	$T_j = 125 \text{ }^\circ\text{C}$	Gate Open	Linear Slope up to $V_D = 67 \% V_{DRM}$		500			V/ $\mu\text{s}$
$(dv/dt)_c^*$	$T_c = 100 \text{ }^\circ\text{C}$	$V_D = V_{DRM}$	$I_T = 17 \text{ A}$		10			V/ $\mu\text{s}$
$t_{gt}$	$T_j = 25 \text{ }^\circ\text{C}$	$V_D = V_{DRM}$	$I_T = 17 \text{ A}$	I-II-III-IV				$\mu\text{s}$

\* For either polarity of electrode  $A_2$  voltage with reference to electrode  $A_1$ .

**PACKAGE MECHANICAL DATA**

TO 220 AB Plastic

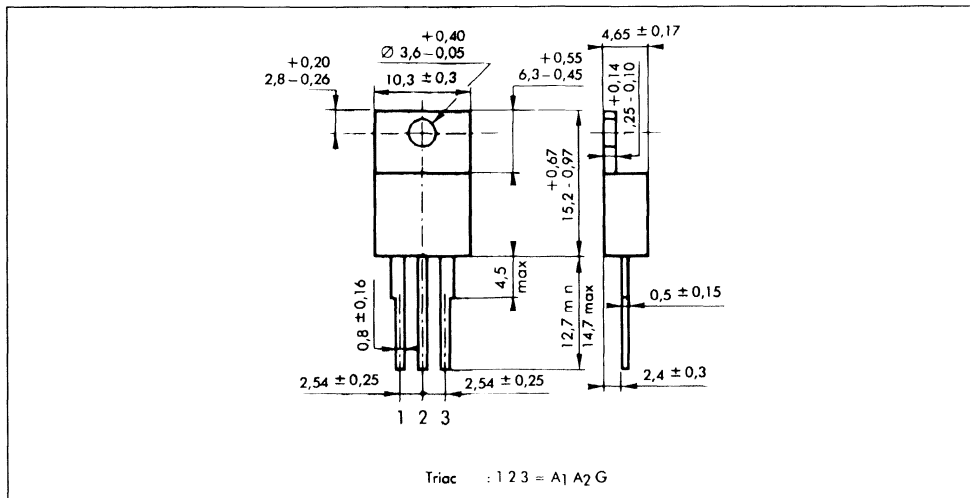

Cooling method : by conduction (method C)  
 Marking : type number  
 Weight : 2 g.

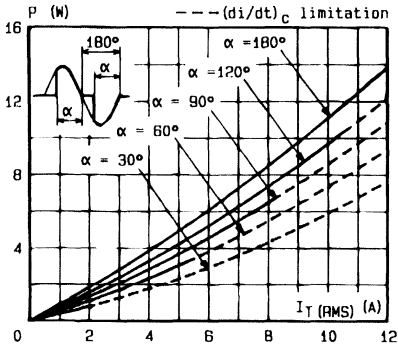

Fig.1 - Maximum mean power dissipation versus RMS on-state current ( $F = 60$  Hz).

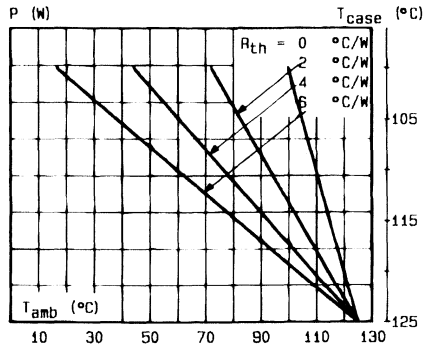

Fig.2 - Correlation between maximum mean power dissipation and maximum allowable temperatures ( $T_{amb}$  and  $T_{case}$ ) for different thermal resistances heatsink + contact.

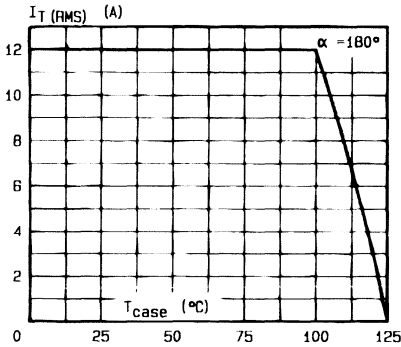

Fig.3 - RMS on-state current versus case temperature.

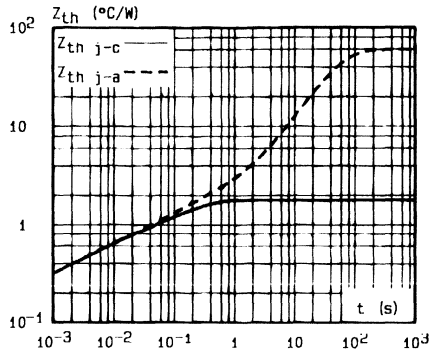

Fig.4 - Thermal transient impedance junction to case and junction to ambient versus pulse duration.

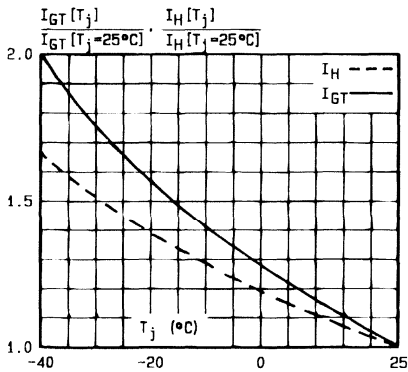

Fig.5 - Relative variation of gate trigger current and holding current versus junction temperature.

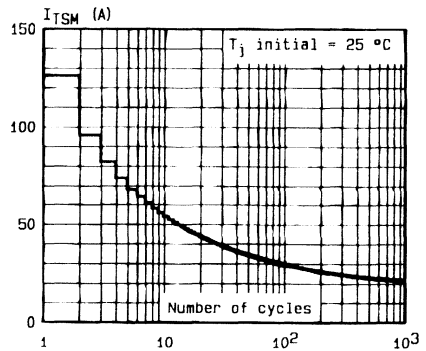

Fig.6 - Non repetitive surge peak on-state current versus number of cycles.

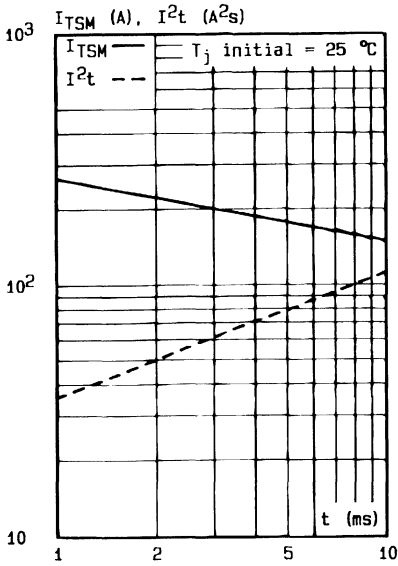

Fig.7 - Non repetitive surge peak on-state current for a sinusoidal pulse with width :  $t \leq 10$  ms, and corresponding value of  $I^2t$ .

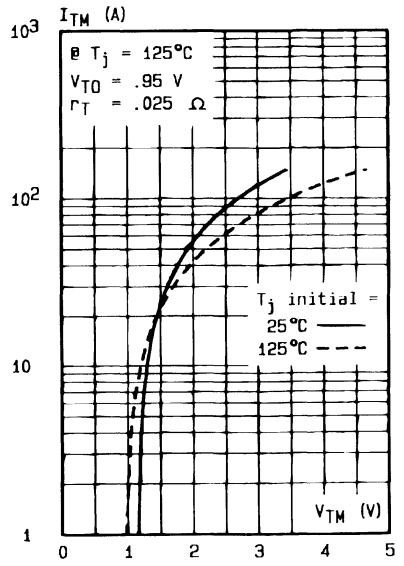
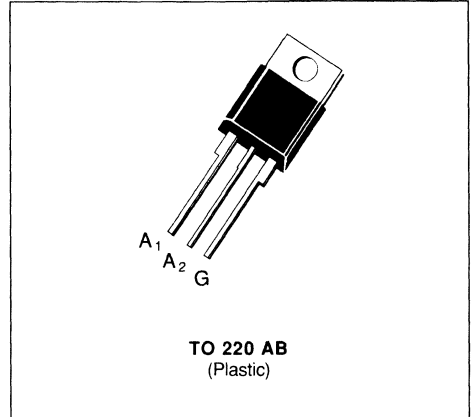

Fig.8 - Un-state characteristics (maximum values).

**TRIACS**

- GLASS PASSIVATED CHIP
- $I_{GT}$  SPECIFIED IN FOUR QUADRANTS

**DESCRIPTION**

New range suited for applications such as phase control and static switching.

**ABSOLUTE RATINGS** (limiting values)

Symbol	Parameter		Value	Unit
$I_{T(RMS)}$	RMS on-state Current (360° conduction angle)	$T_C = 90^\circ\text{C}$	15	A
$I_{TSM}$	Non Repetitive Surge Peak on-state Current ( $T_j$ initial = 25 °C - Half sine wave)	$t = 8.3\text{ ms}$	157	A
		$t = 10\text{ ms}$	150	
$I^2t$	$I^2t$ Value for Fusing	$t = 10\text{ ms}$	112.5	A <sup>2</sup> s
di/dt	Critical Rate of Rise of on-state Current (1)	Repetitive F = 50 Hz	10	A/μs
		Non Repetitive	50	
$T_{stg}$ $T_j$	Storage and Operating Junction Temperature Range		- 40 to 150	°C
			- 40 to 125	°C

Symbol	Parameter	BTB 15-					Unit
		200B	400B	600B	700B	800B	
$V_{DRM}$	Repetitive Peak off-state Voltage (2)	200	400	600	700	800	V

(1)  $I_G = 750\text{ mA}$      $di/dt = 1\text{ A}/\mu\text{s}$

(2)  $T_j = 125^\circ\text{C}$ .

**THERMAL RESISTANCES**

Symbol	Parameter	Value	Unit
$R_{th(j-a)}$	Junction to Ambient	60	°C/W
$R_{th(j-c)}\text{ DC}$	Junction to Case for DC	2.66	°C/W
$R_{th(j-c)}\text{ AC}$	Junction to Case for 360° Conduction Angle (F = 50 Hz)	2	°C/W

**GATE CHARACTERISTICS** (maximum values)

$P_{GM} = 40 \text{ W}$  ( $t_p = 10 \mu\text{s}$ )

$I_{GM} = 4 \text{ A}$  ( $t_p = 10 \mu\text{s}$ )

$P_{G(AV)} = 1 \text{ W}$

$V_{GM} = 16 \text{ V}$  ( $t_p = 10 \mu\text{s}$ )

**ELECTRICAL CHARACTERISTICS**

Symbol	Test Conditions			Quadrants	Min.	Typ.	Max.	Unit
$I_{GT}$	$T_j = 25 \text{ }^\circ\text{C}$ Pulse Duration > 20 $\mu\text{s}$	$V_D = 12 \text{ V}$	$R_L = 33 \text{ } \Omega$	I-II-III			50	mA
				IV			75	
$V_{GT}$	$T_j = 25 \text{ }^\circ\text{C}$ Pulse Duration > 20 $\mu\text{s}$	$V_D = 12 \text{ V}$	$R_L = 33 \text{ } \Omega$	I-II-III-IV			1.5	V
$V_{GD}$	$T_j = 125 \text{ }^\circ\text{C}$	$V_D = V_{DRM}$	$R_L = 3.3 \text{ k}\Omega$	I-II-III-IV	0.2			V
$I_H^*$	$T_j = 25 \text{ }^\circ\text{C}$	$I_T = 100 \text{ mA}$	Gate Open				50	mA
$I_L$	$T_j = 25 \text{ }^\circ\text{C}$ Pulse Duration > 20 $\mu\text{s}$	$V_D = 12 \text{ V}$	$I_G = 150 \text{ mA}$	I-III-IV		50		mA
				II		100		
$V_{TM}^*$	$T_j = 25 \text{ }^\circ\text{C}$	$I_{TM} = 21 \text{ A}$	$t_p = 10 \text{ ms}$				1.5	V
$I_{DRM}^*$	$V_{DRM}$ Specified						0.01	mA
							2	
$dv/dt^*$	$T_j = 125 \text{ }^\circ\text{C}$	Gate Open	Linear Slope up to $V_D = 67 \% V_{DRM}$		250	500		V/ $\mu\text{s}$
$(dv/dt)_c^*$	$T_C = 90 \text{ }^\circ\text{C}$	$V_D = V_{DRM}$	$I_T = 21 \text{ A}$ $(di/dt)_c = 6.7 \text{ A/ms}$		10			V/ $\mu\text{s}$
$t_{gt}$	$T_j = 25 \text{ }^\circ\text{C}$	$V_D = V_{DRM}$	$I_T = 21 \text{ A}$ $I_G = 500 \text{ mA}$ $di_G/dt = 3.5 \text{ A}/\mu\text{s}$	I-II-III-IV		2		$\mu\text{s}$

\* For either polarity of electrode  $A_2$  voltage with reference to electrode  $A_1$ .

**PACKAGE MECHANICAL DATA**

TO 220 AB Plastic

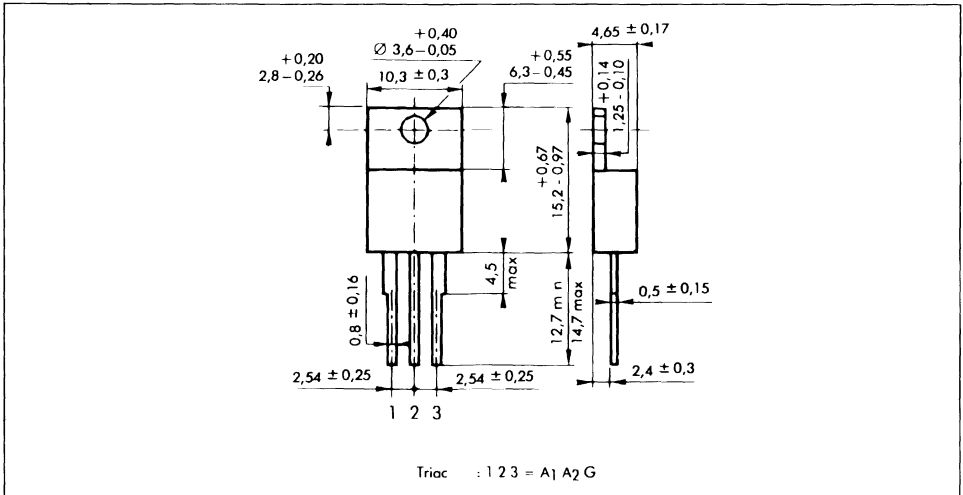

Cooling method : by conduction (method C)

Marking : type number

Weight : 2 g.

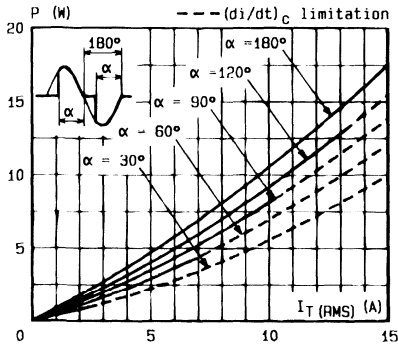

Fig. 1 - Maximum mean power dissipation versus RMS on-state current ( $f = 60 \text{ Hz}$ ).

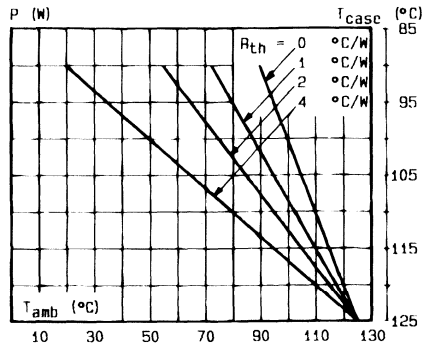

Fig. 2 - Correlation between maximum mean power dissipation and maximum allowable temperatures ( $T_{amb}$  and  $T_{case}$ ) for different thermal resistances heatsink + contact.

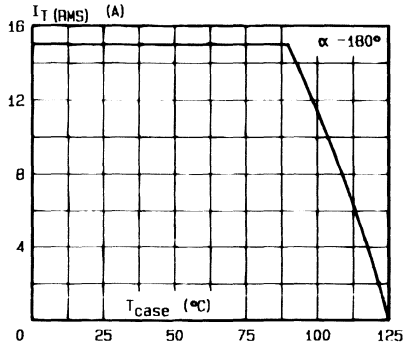

Fig. 3 - RMS on-state current versus case temperature.

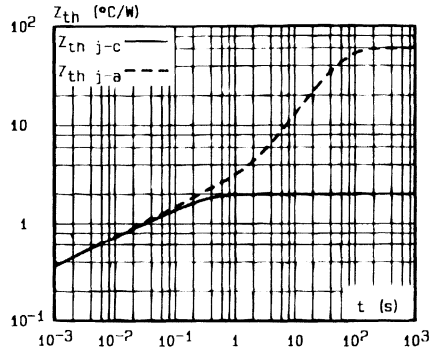

Fig. 4 - Thermal transient impedance junction to case and junction to ambient versus pulse duration.

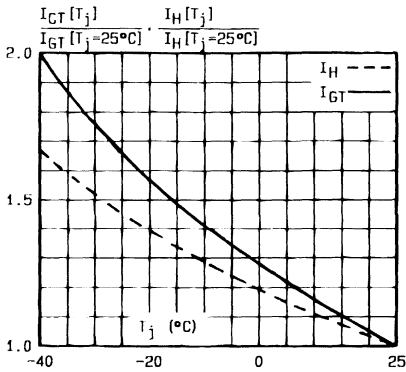

Fig. 5 - Relative variation of gate trigger current and holding current versus junction temperature.

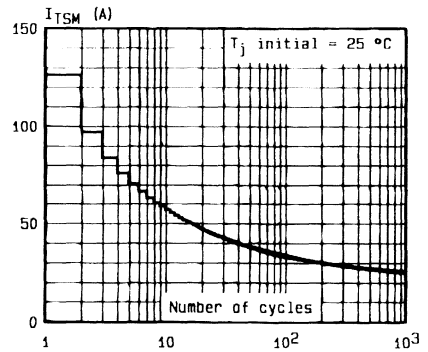

Fig. 6 - Non repetitive surge peak on-state current versus number of cycles.

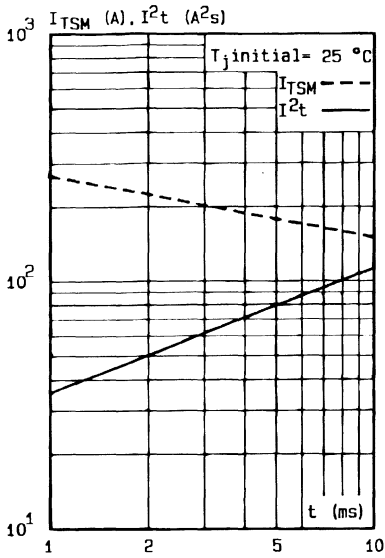

Fig.7 - Non repetitive surge peak on-state current for a sinusoidal pulse with width:  $t \leq 10\text{ms}$ , and corresponding value of  $I^2t$ .

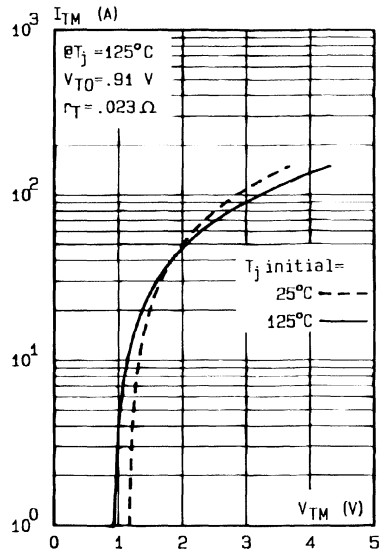
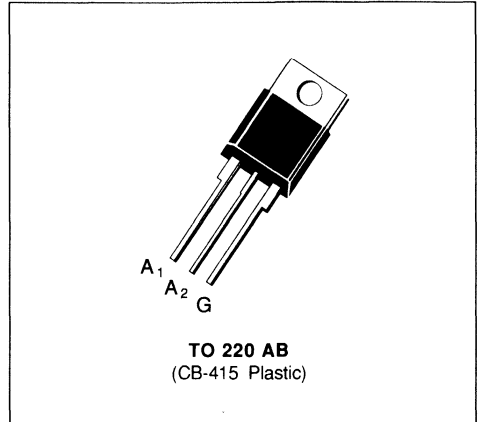

Fig.8 - On-state characteristic (maximum values).



**SNUBBERLESS TRIACS**

- $I_{TRMS} = 16 \text{ A}$  at  $T_c = 90^\circ\text{C}$ .
- $V_{DRM} : 200 \text{ V}$  to  $800 \text{ V}$ .
- $I_{GT} = 75 \text{ mA}$  (QI-II-III).
- GLASS PASSIVATED CHIP.
- HIGH SURGE CURRENT :  $I_{TSM} = 150 \text{ A}$ .
- HIGH COMMUTATION CAPABILITY :  
 $(di/dt)_c > 21 \text{ A} / \text{ms}$  without snubber.

**DESCRIPTION**

New range suited for applications such as phase control and static switching on inductive or resistive load.

**ABSOLUTE RATINGS** (limiting values)

Symbol	Parameter		Value	Unit
$I_{TRMS}$	RMS on-state current (360° conduction angle)	$T_c = 90^\circ\text{C}$	16	A
$I_{TSM}$	Non repetitive surge peak on-state current ( $T_j$ initial = $25^\circ\text{C}$ )	$t = 8.3 \text{ ms}$	157	A
		$t = 10 \text{ ms}$	150	
$I^2t$	$I^2t$ value	$t = 10 \text{ ms}$	112	$\text{A}^2\text{s}$
$di/dt$	Critical rate of rise of on-state current (1)	Repetitive $F = 50 \text{ Hz}$	20	A/ $\mu\text{s}$
		Non Repetitive	100	
$T_{stg}$ $T_j$	Storage and operating junction temperature range		- 40, + 150 - 40, + 125	$^\circ\text{C}$ $^\circ\text{C}$

Symbol	Parameter	BTB 16-					Unit
		200 AW	400 AW	600 AW	700 AW	800 AW	
$V_{DRM}$	Repetitive peak off-state voltage (2)	$\pm 200$	$\pm 400$	$\pm 600$	$\pm 700$	$\pm 800$	V

(1) Gate supply :  $I_G = 750 \text{ mA} - di_G / dt = 1 \text{ A} / \mu\text{s}$ .

(2)  $T_j = 125^\circ\text{C}$ .

**THERMAL RESISTANCES**

Symbol	Parameter	Value	Unit
$R_{th(j-a)}$	Junction to ambient	60	°C/W
$R_{th(j-c)} DC$	Junction to case for DC	2.4	°C/W
$R_{th(j-c)} AC$	Junction to case for 360 ° conduction angle (F = 50 Hz)	1.8	°C/W

**GATE CHARACTERISTICS (maximum values)**

$P_{GM} = 40 W$  (t = 10 μs)    $P_{G(AV)} = 1 W$     $I_{GM} = 4 A$  (t = 10 μs)    $V_{GM} = 16 V$  (t = 10 μs).

**ELECTRICAL CHARACTERISTICS**

Symbol	Test Conditions	Quadrants	Min.	Typ.	Max.	Unit
$I_{GT}$	$T_j = 25\text{ °C}$ $V_D = 12 V$ $R_L = 33\ \Omega$ Pulse duration > 20 μs	I-II-III	2		75	mA
$V_{GT}$	$T_j = 25\text{ °C}$ $V_D = 12 V$ $R_L = 33\ \Omega$ Pulse duration > 20 μs	I-II-III			1.5	V
$V_{GD}$	$T_j = 125\text{ °C}$ $V_D = V_{DRM}$ $R_L = 3.3\ k\Omega$ Pulse duration > 20 μs	I-II-III	0.2			V
$I_H^*$	$T_j = 25\text{ °C}$ $I_T = 100\text{ mA}$ Gate open $R_L = 140\ \Omega$				75	mA
$I_L$	$T_j = 25\text{ °C}$ $V_D = 12 V$ Pulse duration > 20 μs	I-III		75		mA
		II		150		
$V_{TM}^*$	$T_j = 25\text{ °C}$ $I_{TM} = 22.5\text{ A}$ $t_p = 10\text{ ms}$				1.5	V
$I_{DRM}^*$	$T_j = 25\text{ °C}$ $T_j = 125\text{ °C}$	$V_{DRM}$ rated	Gate open		0.01	mA
					2	
$dv/dt^*$	$T_j = 125\text{ °C}$ Gate open Linear slope up to 0.67 $V_{DRM}$		750	1000		V/μs
$(di/dt)_c^*$	$T_j = 125\text{ °C}$ $V_{DRM}$ rated Without snubber		21	42		A/ms
$t_{gt}$	$T_j = 25\text{ °C}$ $di_G/dt = 3.5\text{ A}/\mu\text{s}$ $I_G = 500\text{ mA}$ $I_T = 22.5\text{ A}$ $V_D = V_{DRM}$	I-II-III		2		μs

\* For either polarity of electrode A<sub>2</sub> voltage with reference to electrode A<sub>1</sub>.

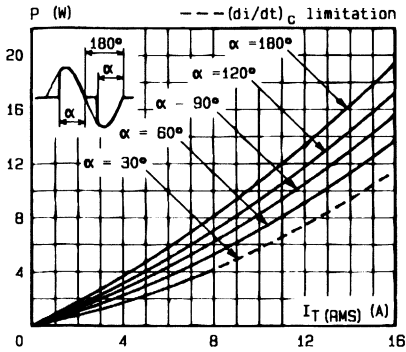

Fig. 1 - Maximum mean power dissipation versus RMS on-state current ( $F = 60$  Hz).

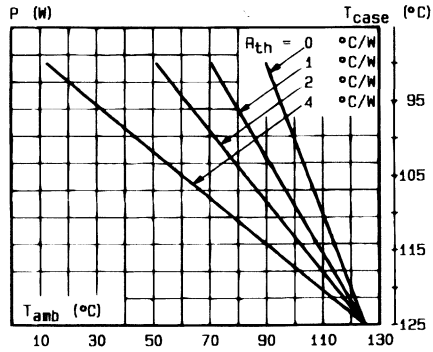

Fig. 2 - Correlation between maximum mean power dissipation and maximum allowable temperatures ( $T_{amb}$  and  $T_{case}$ ) for different thermal resistances (heatsink + contact).

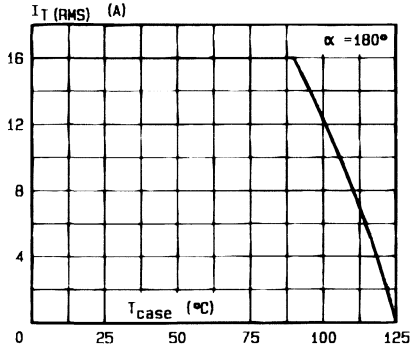

Fig. 3 - RMS on-state current versus case temperature.

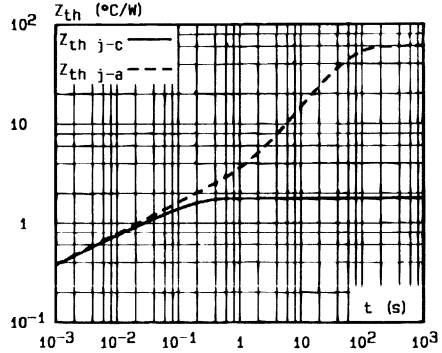

Fig. 4 - Thermal transient impedance junction to case and junction to ambient versus pulse duration.

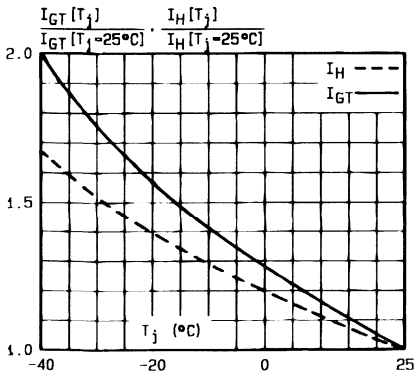

Fig. 5 - Relative variation of gate trigger current and holding current versus junction temperature.

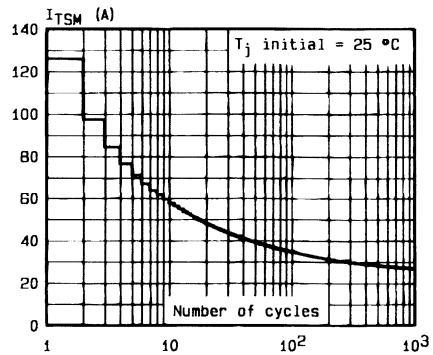

Fig. 6 - Non repetitive surge peak on-state current versus number of cycles.

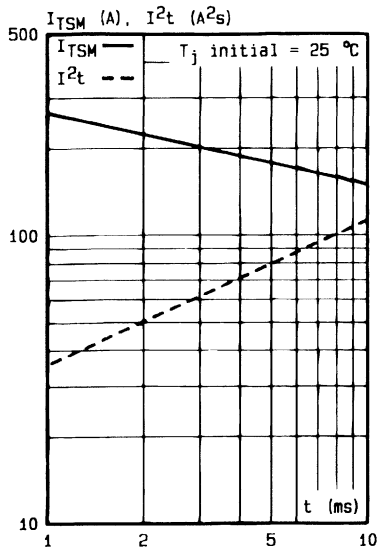

Fig.7 - Non repetitive surge peak on-state current for a sinusoidal pulse with width :  $t \leq 10$  ms, and corresponding value of  $I^2t$ .

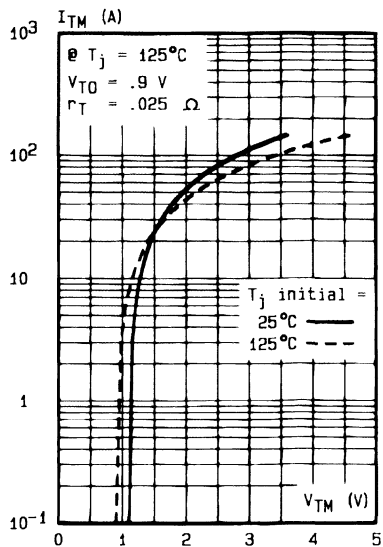
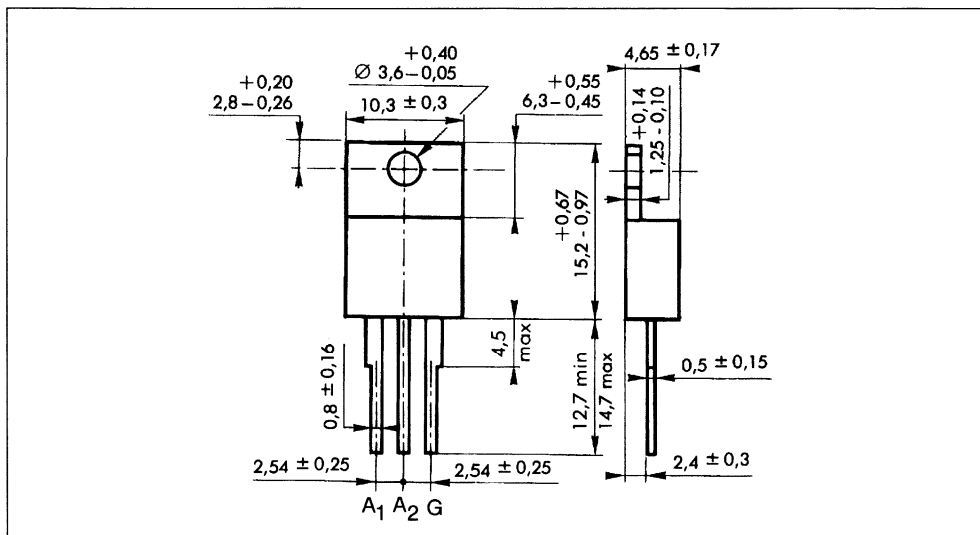

Fig.8 - On-state characteristics (maximum values).

**PACKAGE MECHANICAL DATA**

TO 220 AB (CB-415) Plastic



Cooling method : by conduction (method C)  
 Marking : type number  
 Weight : 2 g

**TRIACS**

- GLASS PASSIVATED CHIP
- EXCELLENT  $(dv/dt)_c > 10 \text{ V}/\mu\text{s}$
- $I_{GT}$  SPECIFIED IN FOUR QUADRANTS

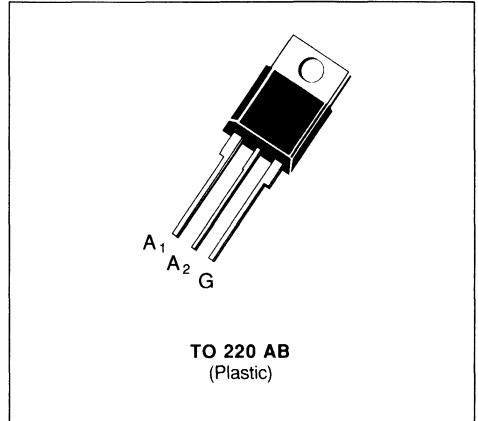
**DESCRIPTION**

New range suited for applications such as phase control and static switching.

**ABSOLUTE RATINGS** (limiting values)

Symbol	Parameter	Value	Unit
$I_{T(RMS)}$	RMS on state Current (360° conduction angle)	$T_C = 90 \text{ }^\circ\text{C}$ 16	A
$I_{TSM}$	Non Repetitive Surge Peak on-state Current ( $T_j$ initial = 25 °C - Half sine wave)	$t = 8.3 \text{ ms}$	170
		$t = 10 \text{ ms}$	160
$I^2t$	$I^2t$ Value for Fusing	$t = 10 \text{ ms}$ 128	$\text{A}^2\text{s}$
$di/dt$	Critical Rate of Rise of on-state Current (1)	Repetitive $F = 50 \text{ Hz}$	10
		Non Repetitive	50
$T_{stg}$ $T_j$	Storage and Operating Junction Temperature Range	- 40 to 150	$^\circ\text{C}$
		- 40 to 125	$^\circ\text{C}$

Symbol	Parameter	BTB 16-					Unit
		200B	400B	600B	700B	800B	
$V_{DRM}$	Repetitive Peak off-state Voltage (2)	200	400	600	700	800	V

(1)  $I_G = 1 \text{ A}$   $di_G/dt = 1 \text{ A}/\mu\text{s}$

(2)  $T_j = 125 \text{ }^\circ\text{C}$ .

**THERMAL RESISTANCES**

Symbol	Parameter	Value	Unit
$R_{th(j-a)}$	Junction to Ambient	60	$^\circ\text{C}/\text{W}$
$R_{th(j-c)} \text{ DC}$	Junction to Case for DC	2.5	$^\circ\text{C}/\text{W}$
$R_{th(j-c)} \text{ AC}$	Junction to Case for 360° Conduction Angle ( $F = 50 \text{ Hz}$ )	1.88	$^\circ\text{C}/\text{W}$

**GATE CHARACTERISTICS** (maximum values)

$P_{GM} = 40 \text{ W}$  ( $t_p = 10 \mu\text{s}$ )       $I_{GM} = 4 \text{ A}$  ( $t_p = 10 \mu\text{s}$ )  
 $P_{G(AV)} = 1 \text{ W}$        $V_{GM} = 16 \text{ V}$  ( $t_p = 10 \mu\text{s}$ )

**ELECTRICAL CHARACTERISTICS**

Symbol	Test Conditions			Quadrants	Min.	Typ.	Max.	Unit
$I_{GT}$	$T_J = 25 \text{ }^\circ\text{C}$ Pulse Duration > 20 $\mu\text{s}$	$V_D = 12 \text{ V}$	$R_L = 33 \text{ } \Omega$	I-II-III			50	mA
				IV			100	
$V_{GT}$	$T_J = 25 \text{ }^\circ\text{C}$ Pulse Duration > 20 $\mu\text{s}$	$V_D = 12 \text{ V}$	$R_L = 33 \text{ } \Omega$	I-II-III-IV			1.5	V
$V_{GD}$	$T_J = 125 \text{ }^\circ\text{C}$	$V_D = V_{DRM}$	$R_L = 3.3 \text{ k}\Omega$	I-II-III-IV	0.2			V
$I_{H^*}$	$T_J = 25 \text{ }^\circ\text{C}$	$I_T = 100 \text{ mA}$	Gate Open				50	mA
$I_L$	$T_J = 25 \text{ }^\circ\text{C}$ Pulse Duration > 20 $\mu\text{s}$	$V_D = 12 \text{ V}$	$I_G = 200 \text{ mA}$	I-III-IV		50		mA
				II		100		
$V_{TM}^*$	$T_J = 25 \text{ }^\circ\text{C}$	$I_{TM} = 22.5 \text{ A}$	$t_p = 10 \text{ ms}$				1.6	V
$I_{DRM}^*$	$V_{DRM}$ Specified	$T_J = 25 \text{ }^\circ\text{C}$					0.01	mA
		$T_J = 125 \text{ }^\circ\text{C}$					0.5	
$dv/dt^*$	$T_J = 125 \text{ }^\circ\text{C}$	Gate Open	Linear Slope up to $V_D = 67\% V_{DRM}$		250	500		V/ $\mu\text{s}$
$(dv/dt)_c^*$	$T_C = 90 \text{ }^\circ\text{C}$ $(di/dt)_c = 7 \text{ A/ms}$	$V_D = V_{DRM}$	$I_T = 22.5 \text{ A}$		10			V/ $\mu\text{s}$
$t_{gt}$	$T_J = 25 \text{ }^\circ\text{C}$	$V_D = V_{DRM}$ $I_G = 500 \text{ mA}$	$I_T = 22.5 \text{ A}$ $di_G/dt = 3.5 \text{ A}/\mu\text{s}$	I-II-III-IV		2		$\mu\text{s}$

\* For either polarity of electrode  $A_2$  voltage with reference to electrode  $A_1$ .

**PACKAGE MECHANICAL DATA**

TO 220 AB Plastic

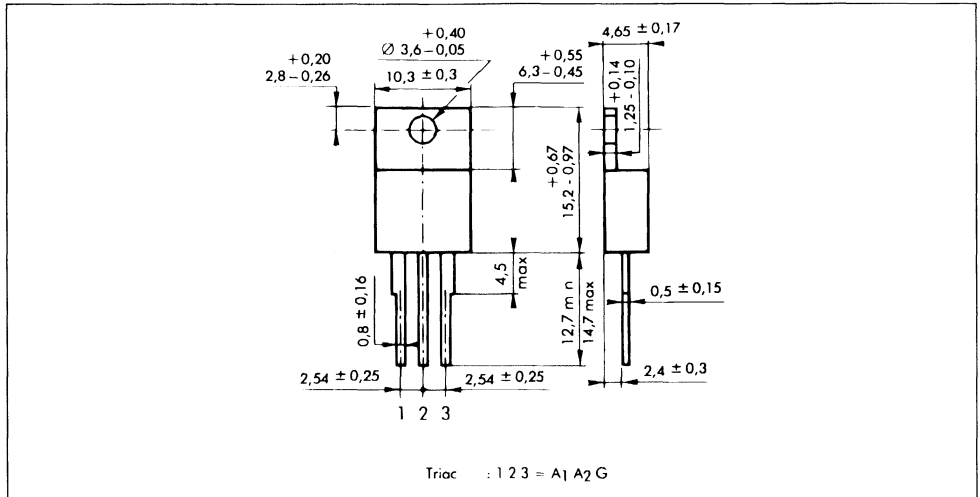

Cooling method : by conduction (method C)  
 Marking : type number  
 Weight : 2 g.

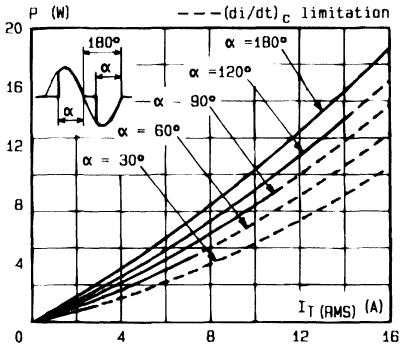

Fig. 1 - Maximum mean power dissipation versus RMS on-state current ( $f = 60 \text{ Hz}$ ).

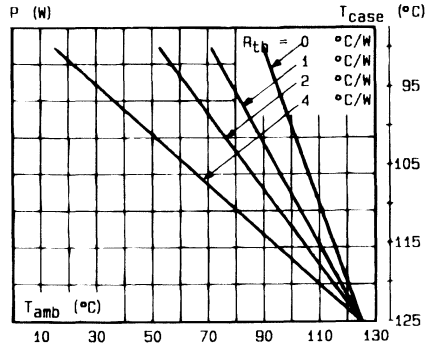

Fig. 2 - Correlation between maximum mean power dissipation and maximum allowable temperatures ( $T_{amb}$  and  $T_{case}$ ) for different thermal resistances heatsink + contact.

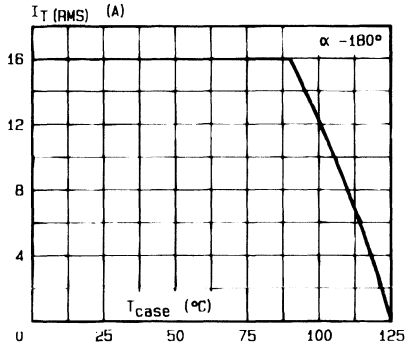

Fig. 3 - RMS on-state current versus case temperature.

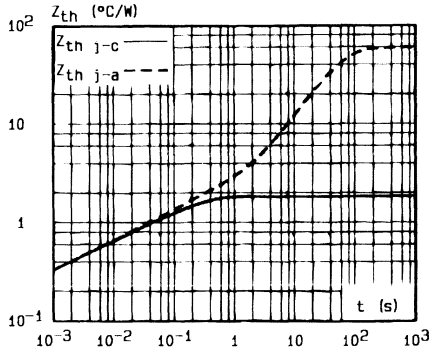

Fig. 4 - Thermal transient impedance junction to case and junction to ambient versus pulse duration.

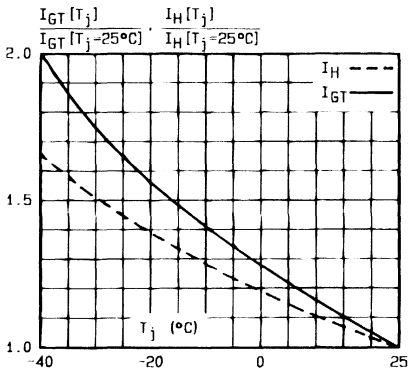

Fig. 5 - Relative variation of gate trigger current and holding current versus junction temperature.

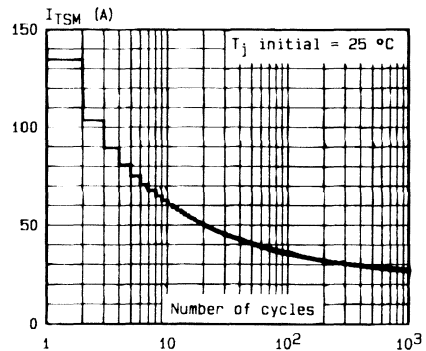

Fig. 6 - Non repetitive surge peak on-state current versus number of cycles.

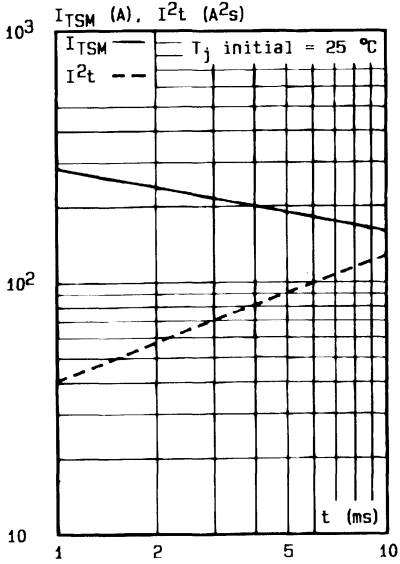

Fig.7 - Non repetitive surge peak on-state current for a sinusoidal pulse with width :  $t \leq 10$  ms, and corresponding value of  $I^2t$ .

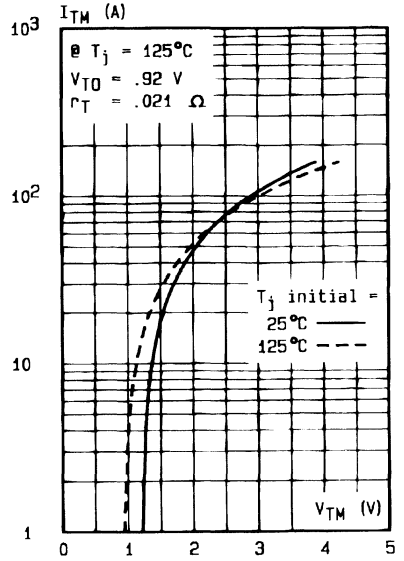
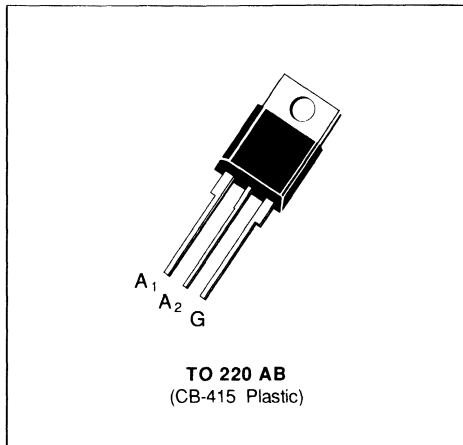

Fig.8 - On-state characteristics (maximum values).



**SNUBBERLESS TRIACS**

- $I_{TRMS} = 16 \text{ A}$  at  $T_c = 90 \text{ }^\circ\text{C}$ .
- $V_{DRM} : 200 \text{ V}$  to  $800 \text{ V}$ .
- $I_{GT} = 50 \text{ mA}$  (QI-II-III).
- GLASS PASSIVATED CHIP.
- HIGH SURGE CURRENT :  $I_{TSM} = 150 \text{ A}$ .
- HIGH COMMUTATION CAPABILITY :  
 $(di/dt)_c > 14 \text{ A/ms}$  without snubber.

**DESCRIPTION**

New range suited for applications such as phase control and static switching on inductive or resistive load.

**ABSOLUTE RATINGS** (limiting values)

Symbol	Parameter	Value	Unit
$I_{TRMS}$	RMS on-state current (360 ° conduction angle)	$T_c = 90 \text{ }^\circ\text{C}$ 16	A
$I_{TSM}$	Non repetitive surge peak on-state current ( $T_j$ initial = $25 \text{ }^\circ\text{C}$ )	$t = 8.3 \text{ ms}$	157
		$t = 10 \text{ ms}$	150
$I^2t$	$I^2t$ value	$t = 10 \text{ ms}$	$\text{A}^2\text{s}$
$di/dt$	Critical rate of rise of on-state current (1)	Repetitive $F = 50 \text{ Hz}$	20
		Non Repetitive	100
$T_{stg}$ $T_j$	Storage and operating junction temperature range	- 40, + 150 - 40, + 125	$^\circ\text{C}$ $^\circ\text{C}$

Symbol	Parameter	BTB 16-					Unit
		200 BW	400 BW	600 BW	700 BW	800 BW	
$V_{DRM}$	Repetitive peak off-state voltage (2)	$\pm 200$	$\pm 400$	$\pm 600$	$\pm 700$	$\pm 800$	V

(1) Gate supply :  $I_G = 500 \text{ mA}$  –  $di_G/dt = 1 \text{ A}/\mu\text{s}$ .

(2)  $T_j = 125 \text{ }^\circ\text{C}$ .

**THERMAL RESISTANCES**

Symbol	Parameter	Value	Unit
$R_{th(j-a)}$	Junction to ambient	60	°C/W
$R_{th(j-c)} DC$	Junction to case for DC	2.4	°C/W
$R_{th(j-c)} AC$	Junction to case for 360 ° conduction angle (F = 50 Hz)	1.8	°C/W

**GATE CHARACTERISTICS (maximum values)**
 $P_{GM} = 40 W$  ( $t = 10 \mu s$ )    $P_{G(AV)} = 1 W$     $I_{GM} = 4 A$  ( $t = 10 \mu s$ )    $V_{GM} = 16 V$  ( $t = 10 \mu s$ ).

**ELECTRICAL CHARACTERISTICS**

Symbol	Test Conditions	Quadrants	Min.	Typ.	Max.	Unit
$I_{GT}$	$T_j = 25 \text{ °C}$ $V_D = 12 V$ $R_L = 33 \Omega$ Pulse duration > 20 $\mu s$	I-II-III	2		50	mA
$V_{GT}$	$T_j = 25 \text{ °C}$ $V_D = 12 V$ $R_L = 33 \Omega$ Pulse duration > 20 $\mu s$	I-II-III			1.5	V
$V_{GD}$	$T_j = 125 \text{ °C}$ $V_D = V_{DRM}$ $R_L = 3.3 k\Omega$ Pulse duration > 20 $\mu s$	I-II-III	0.2			V
$I_H^*$	$T_j = 25 \text{ °C}$ $I_T = 100 mA$ Gate open $R_L = 140 \Omega$				50	mA
$I_L$	$T_j = 25 \text{ °C}$ $V_D = 12 V$ $I_G = 500 mA$ Pulse duration > 20 $\mu s$	I-III		50		mA
		II		100		
$V_{TM}^*$	$T_j = 25 \text{ °C}$ $I_{TM} = 22.5 A$ $t_p = 10 ms$				1.5	V
$I_{DRM}^*$	$T_j = 25 \text{ °C}$ $T_j = 125 \text{ °C}$	$V_{DRM}$ rated	Gate open		0.01	mA
					2	
$dv/dt^*$	$T_j = 125 \text{ °C}$ Gate open Linear slope up to 0.67 $V_{DRM}$		500	750		V/ $\mu s$
$(di/dt)_c^*$	$T_j = 125 \text{ °C}$ $V_{DRM}$ rated Without snubber		14	28		A/ms
$t_{gt}$	$T_j = 25 \text{ °C}$ $di_G/dt = 3.5 A/\mu s$ $I_G = 500 mA$ $I_T = 22.5 A$ $V_D = V_{DRM}$	I-II-III		2		$\mu s$

\* For either polarity of electrode  $A_2$  voltage with reference to electrode  $A_1$ .

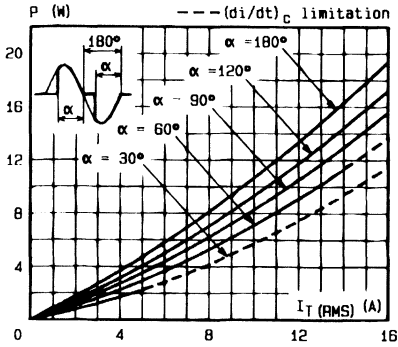

Fig.1 - Maximum mean power dissipation versus RMS on-state current (F = 60 Hz).

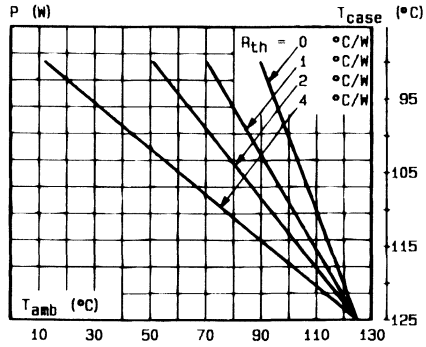

Fig.2 - Correlation between maximum mean power dissipation and maximum allowable temperatures (T<sub>amb</sub> and T<sub>case</sub>) for different thermal resistances heatsink + contact.

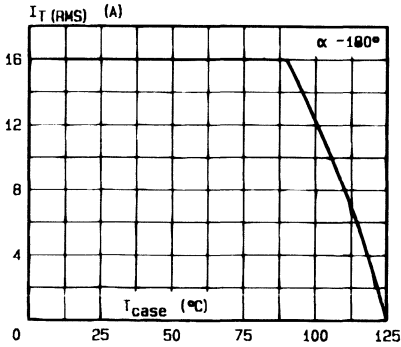

Fig.3 - RMS on-state current versus case temperature.

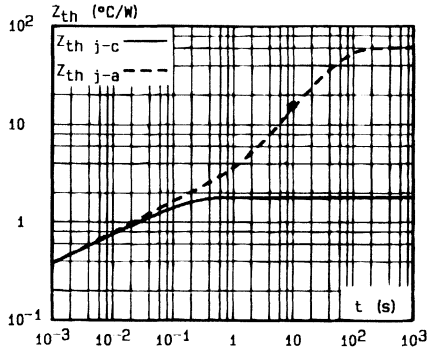

Fig.4 - Thermal transient impedance junction to case and junction to ambient versus pulse duration.

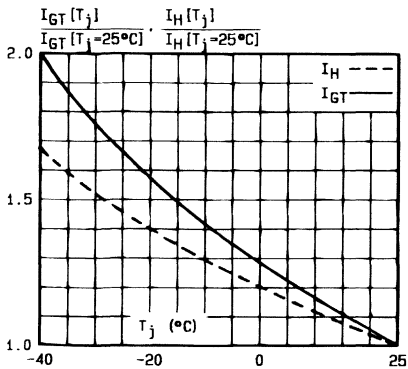

Fig.5 - Relative variation of gate trigger current and holding current versus junction temperature.

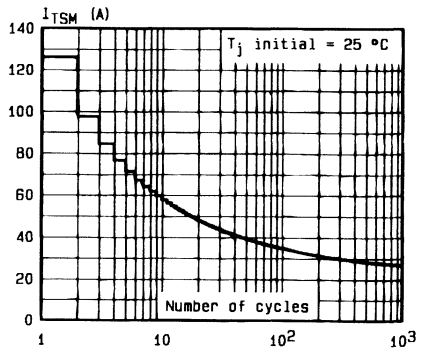

Fig.6 - Non repetitive surge peak on-state current versus number of cycles.

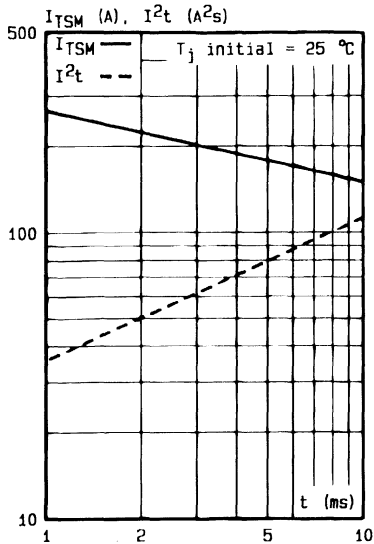

Fig.7 - Non repetitive surge peak on-state current for a sinusoidal pulse with width :  $t \leq 10$  ms, and corresponding value of  $I^2t$ .

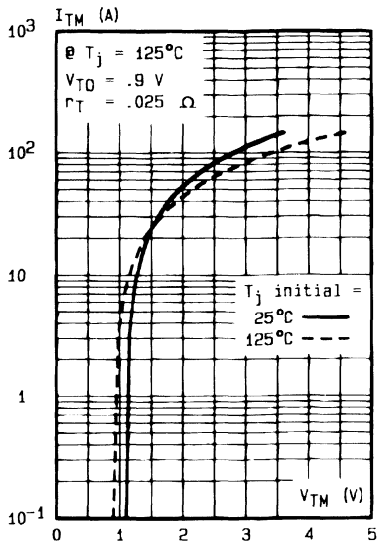
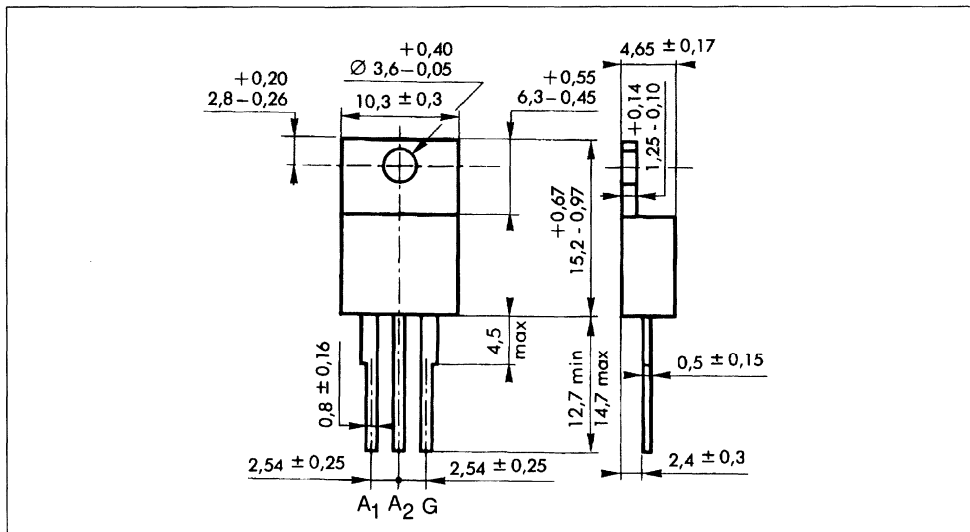

Fig.8 - On-state characteristics (maximum values).

**PACKAGE MECHANICAL DATA**

TO 220 AB (CB-415) Plastic



Cooling method : by conduction (method C)

Marking : type number

Weight : 2 g

**SNUBBERLESS TRIACS**

- $I_{TRMS} = 16 \text{ A}$  at  $T_c = 90^\circ\text{C}$ .
- $V_{DRM} : 200 \text{ V}$  to  $800 \text{ V}$ .
- $I_{GT} = 35 \text{ mA}$  (QI-II-III).
- GLASS PASSIVATED CHIP.
- HIGH SURGE CURRENT :  $I_{TSM} = 150 \text{ A}$ .
- HIGH COMMUTATION CAPABILITY :  
 $(di/dt)_c > 8.5 \text{ A/ms}$  without snubber.

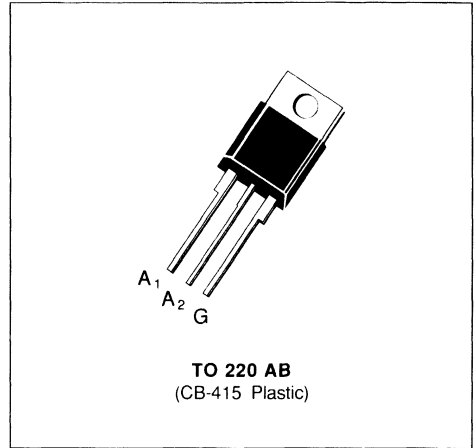
**DESCRIPTION**

New range suited for applications such as phase control and static switching on inductive or resistive load.

**ABSOLUTE RATINGS** (limiting values)

Symbol	Parameter		Value	Unit
$I_{TRMS}$	RMS on-state current (360° conduction angle)	$T_c = 90^\circ\text{C}$	16	A
$I_{TSM}$	Non repetitive surge peak on-state current ( $T_j$ initial = $25^\circ\text{C}$ )	$t = 8.3 \text{ ms}$	157	A
		$t = 10 \text{ ms}$	150	
$I^2t$	$I^2t$ value	$t = 10 \text{ ms}$	112	$\text{A}^2\text{s}$
$di/dt$	Critical rate of rise of on-state current (1)	Repetitive $F = 50 \text{ Hz}$	20	A/ $\mu\text{s}$
		Non Repetitive	100	
$T_{stg}$ $T_j$	Storage and operating junction temperature range		- 40, + 150 - 40, + 125	$^\circ\text{C}$ $^\circ\text{C}$

Symbol	Parameter	BTB 16-					Unit
		200 CW	400 CW	600 CW	700 CW	800 CW	
$V_{DRM}$	Repetitive peak off-state voltage (2)	$\pm 200$	$\pm 400$	$\pm 600$	$\pm 700$	$\pm 800$	V

(1) Gate supply :  $I_G = 350 \text{ mA}$  -  $di_G / dt = 1 \text{ A} / \mu\text{s}$ .

(2)  $T_j = 125^\circ\text{C}$ .

**THERMAL RESISTANCES**

Symbol	Parameter	Value	Unit
$R_{th(j-a)}$	Junction to ambient	60	°C/W
$R_{th(j-c) DC}$	Junction to case for DC	2.4	°C/W
$R_{th(j-c) AC}$	Junction to case for 360° conduction angle (F = 50 Hz)	1.8	°C/W

**GATE CHARACTERISTICS (maximum values)**
 $P_{GM} = 40 \text{ W (} t = 10 \mu\text{s)}$     $P_{G(AV)} = 1 \text{ W}$     $I_{GM} = 4 \text{ A (} t = 10 \mu\text{s)}$     $V_{GM} = 16 \text{ V (} t = 10 \mu\text{s)}$ .

**ELECTRICAL CHARACTERISTICS**

Symbol	Test Conditions			Quadrants	Min.	Typ.	Max.	Unit
$I_{GT}$	$T_j = 25 \text{ °C}$ Pulse duration > 20 $\mu\text{s}$	$V_D = 12 \text{ V}$	$R_L = 33 \text{ }\Omega$	I-II-III	1		35	mA
$V_{GT}$	$T_j = 25 \text{ °C}$ Pulse duration > 20 $\mu\text{s}$	$V_D = 12 \text{ V}$	$R_L = 33 \text{ }\Omega$	I-II-III			1.5	V
$V_{GD}$	$T_j = 125 \text{ °C}$ Pulse duration > 20 $\mu\text{s}$	$V_D = V_{DRM}$	$R_L = 3.3 \text{ k}\Omega$	I-II-III	0.2			V
$I_H^*$	$T_j = 25 \text{ °C}$ Gate open	$I_T = 100 \text{ mA}$ $R_L = 140 \text{ }\Omega$					35	mA
$I_L$	$T_j = 25 \text{ °C}$ Pulse duration > 20 $\mu\text{s}$	$V_D = 12 \text{ V}$	$I_G = 350 \text{ mA}$	I-III			50	mA
				II			80	
$V_{TM}^*$	$T_j = 25 \text{ °C}$	$I_{TM} = 22.5 \text{ A}$	$t_p = 10 \text{ ms}$				1.5	V
$I_{DRM}^*$	$T_j = 25 \text{ °C}$	$V_{DRM}$ rated	Gate open				0.01	mA
	$T_j = 125 \text{ °C}$						2	
$dv/dt^*$	$T_j = 125 \text{ °C}$ Linear slope up to 0.67 $V_{DRM}$	Gate open			250	500		V/ $\mu\text{s}$
$(di/dt)_c^*$	$T_j = 125 \text{ °C}$ Without snubber	$V_{DRM}$ rated			8.5	17		A/ms
$t_{gt}$	$T_j = 25 \text{ °C}$ $I_T = 22.5 \text{ A}$	$di_G/dt = 1 \text{ A}/\mu\text{s}$ $V_D = V_{DRM}$	$I_G = 350 \text{ mA}$	I-II-III		2		$\mu\text{s}$

\* For either polarity of electrode A<sub>2</sub> voltage with reference to electrode A<sub>1</sub>.

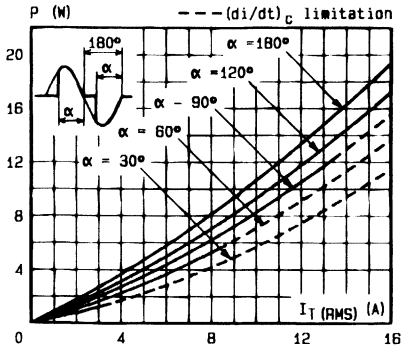

Fig.1 - Maximum mean power dissipation versus RMS on-state current ( $F = 60$  Hz).

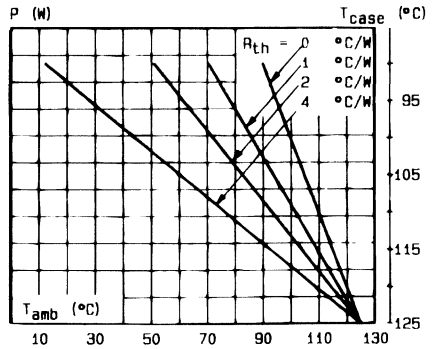

Fig.2 - Correlation between maximum mean power dissipation and maximum allowable temperatures ( $T_{amb}$  and  $T_{case}$ ) for different thermal resistances heatsink + contact.

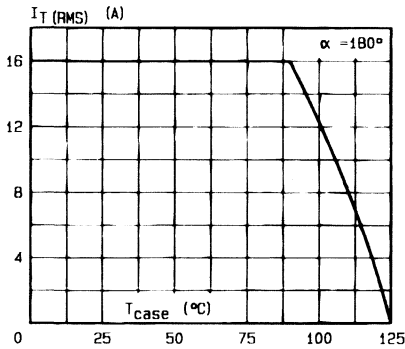

Fig.3 - RMS on-state current versus case temperature.

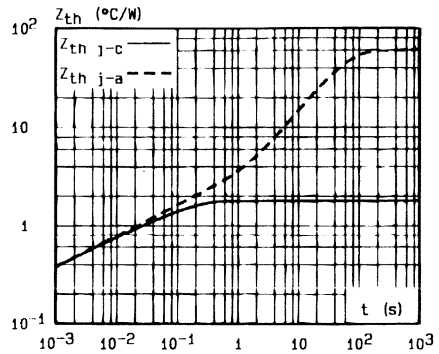

Fig.4 - Thermal transient impedance junction to case and junction to ambient versus pulse duration.

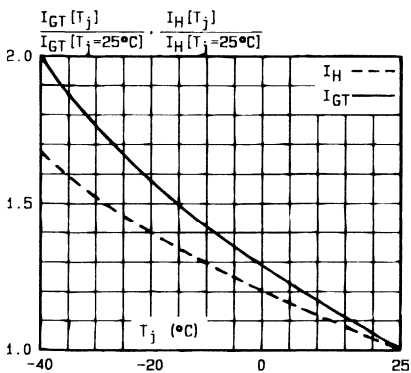

Fig.5 - Relative variation of gate trigger current and holding current versus junction temperature.

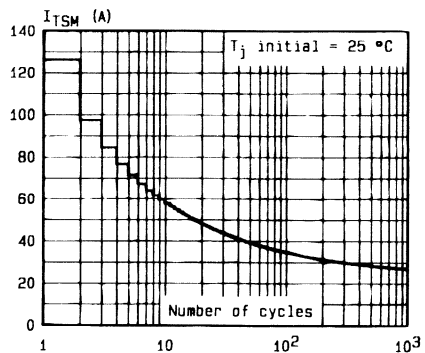

Fig.6 - Non repetitive surge peak on-state current versus number of cycles.

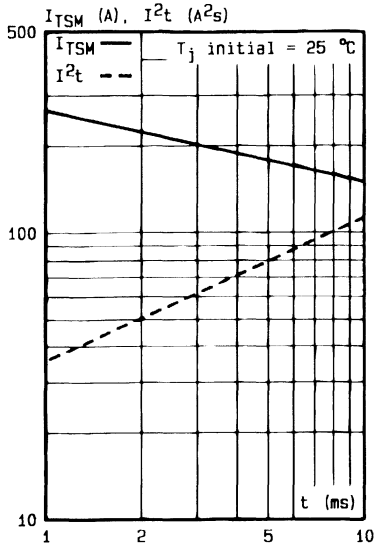

Fig.7 - Non repetitive surge peak on-state current for a sinusoidal pulse with width :  $t \leq 10$  ms, and corresponding value of  $I^2t$ .

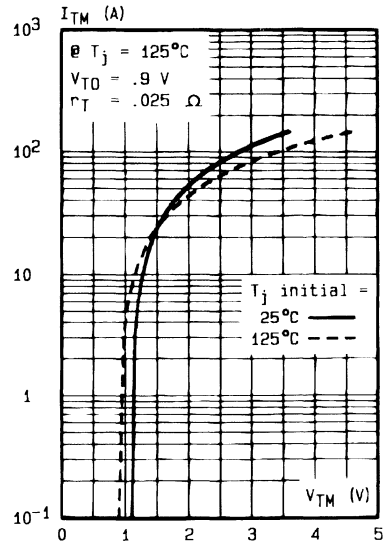
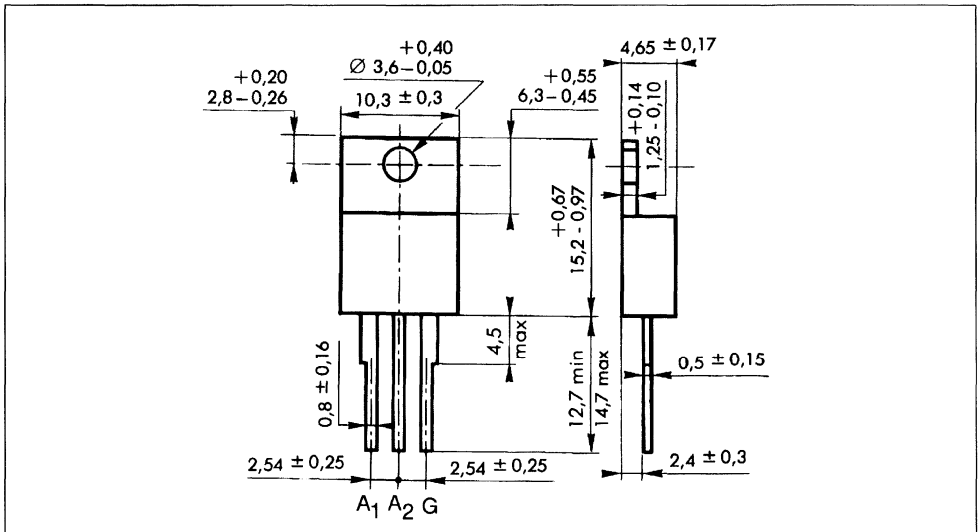

Fig.8 - On-state characteristics (maximum values).

**PACKAGE MECHANICAL DATA**

TO 220 AB (CB-415) Plastic



Cooling method : by conduction (method C)  
 Marking : type number  
 Weight : 2 g



**TRIACS**

- GLASS PASSIVATED CHIP
- $I_{GT}$  SPECIFIED IN FOUR QUADRANTS

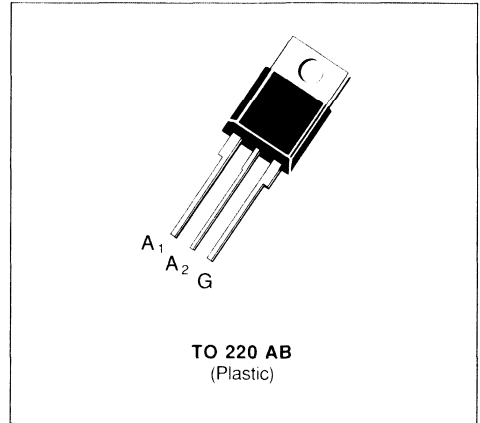
**DESCRIPTION**

New range suited for applications such as phase control and static switching.

**ABSOLUTE RATINGS** (limiting values)

Symbol	Parameter		Value	Unit
$I_{T(RMS)}$	RMS on-state Current (360° conduction angle)	$T_C = 75^\circ C$	25	A
$I_{TSM}$	Non Repetitive Surge Peak on-state Current ( $T_J$ initial = $25^\circ C$ - Half sine wave)	$t = 8.3$ ms	210	A
		$t = 10$ ms	200	
$I^2t$	$I^2t$ Value for Fusing	$t = 10$ ms	200	A <sup>2</sup> s
$di/dt$	Critical Rate of Rise of on-state Current (1)	Repetitive $F = 50$ Hz	10	A/ $\mu$ s
		Non Repetitive	50	
$T_{stg}$ $T_J$	Storage and Operating Junction Temperature Range		- 40 to 150	$^\circ C$
			- 40 to 125	$^\circ C$

Symbol	Parameter	BTB 24-					Unit
		200B	400B	600B	700B	800B	
$V_{DRM}$	Repetitive Peak off-state Voltage (2)	200	400	600	700	800	V

(1)  $I_G = 1$  A  $di_G/dt = 1$  A/ $\mu$ s

(2)  $T_J = 125^\circ C$ .

**THERMAL RESISTANCES**

Symbol	Parameter	Value	Unit
$R_{th(j-a)}$	Junction to Ambient	60	$^\circ C/W$
$R_{th(j-c)}$ DC	Junction to Case for DC	1.97	$^\circ C/W$
$R_{th(j-c)}$ AC	Junction to Case for 360° Conduction Angle ( $F = 50$ Hz)	1.48	$^\circ C/W$

**GATE CHARACTERISTICS** (maximum values)

$P_{GM} = 40 \text{ W}$  ( $t_p = 10 \mu\text{s}$ )

$I_{GM} = 4 \text{ A}$  ( $t_p = 10 \mu\text{s}$ )

$P_{G(AV)} = 1 \text{ W}$

$V_{GM} = 16 \text{ V}$  ( $t_p = 10 \mu\text{s}$ )

**ELECTRICAL CHARACTERISTICS**

Symbol	Test Conditions			Quadrants	Min.	Typ.	Max.	Unit
$I_{GT}$	$T_j = 25 \text{ }^\circ\text{C}$ Pulse Duration > 20 $\mu\text{s}$	$V_D = 12 \text{ V}$	$R_L = 33 \text{ } \Omega$	I-II-III			50	mA
				IV			100	
$V_{GT}$	$T_j = 25 \text{ }^\circ\text{C}$ Pulse Duration > 20 $\mu\text{s}$	$V_D = 12 \text{ V}$	$R_L = 33 \text{ } \Omega$	I-II-III-IV			1.5	V
$V_{GD}$	$T_j = 125 \text{ }^\circ\text{C}$	$V_D = V_{DRM}$	$R_i = 3.3 \text{ k}\Omega$	I-II-III-IV	0.2			V
$I_{H^*}$	$T_j = 25 \text{ }^\circ\text{C}$	$I_T = 100 \text{ mA}$	Gate Open				50	mA
$I_L$	$T_j = 25 \text{ }^\circ\text{C}$ Pulse Duration > 20 $\mu\text{s}$	$V_D = 12 \text{ V}$	$I_G = 200 \text{ mA}$	I-III-IV		50		mA
				II		100		
$V_{TM}^*$	$T_j = 25 \text{ }^\circ\text{C}$	$I_{TM} = 35 \text{ A}$	$t_p = 10 \text{ ms}$				1.8	V
$I_{DRM}^*$	$V_{DRM}$ Specified	$T_j = 25 \text{ }^\circ\text{C}$					0.01	mA
		$T_j = 125 \text{ }^\circ\text{C}$					1	
$dv/dt^*$	$T_j = 125 \text{ }^\circ\text{C}$	Gate Open	$t_p = 10 \text{ ms}$		250	500		V/ $\mu\text{s}$
	Linear Slope up to $V_D = 67\% V_{DRM}$							
$(dv/dt)_C^*$	$T_C = 75 \text{ }^\circ\text{C}$	$V_D = V_{DRM}$	$I_T = 35 \text{ A}$		10			V/ $\mu\text{s}$
	$(di/dt)_C = 11.1 \text{ A/ms}$							
$t_{gt}$	$T_j = 25 \text{ }^\circ\text{C}$	$V_D = V_{DRM}$	$I_T = 35 \text{ A}$	I-II-III-IV		2		$\mu\text{s}$
	$I_G = 500 \text{ mA}$							
	$di_G/dt = 3.5 \text{ A}/\mu\text{s}$							

\* For either polarity of electrode  $A_2$  voltage with reference to electrode  $A_1$ .

**PACKAGE MECHANICAL DATA**

TO 220 AB Plastic

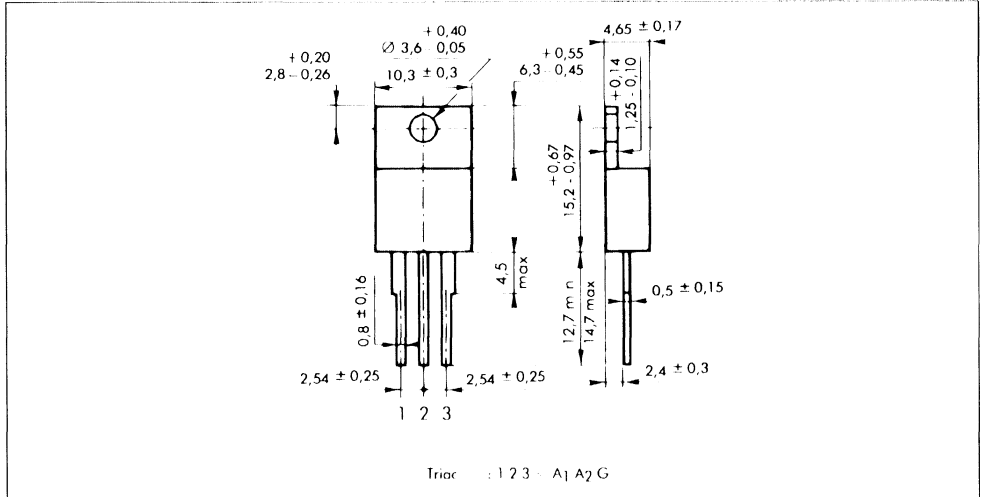

Cooling method : by conduction (method C)

Marking : type number

Weight : 2 g

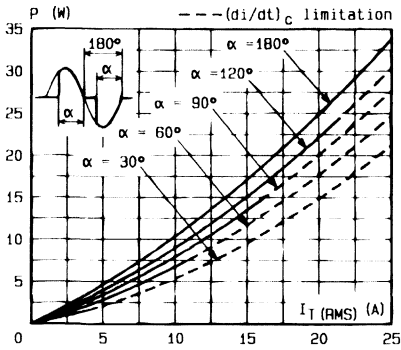

Fig.1 - Maximum mean power dissipation versus RMS on-state current ( $f = 60 \text{ Hz}$ ).

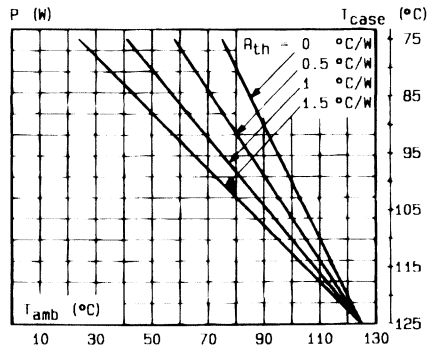

Fig.2 - Correlation between maximum mean power dissipation and maximum allowable temperatures ( $T_{amb}$  and  $T_{case}$ ) for different thermal resistances heatsink + contact.

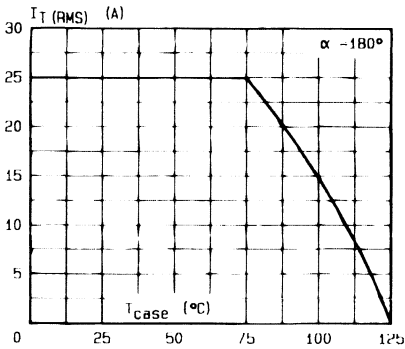

Fig.3 - RMS on state current versus case temperature.

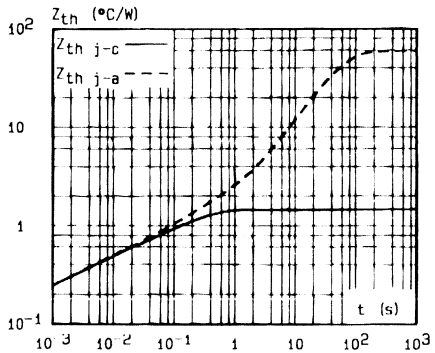

Fig.4 - Thermal transient impedance junction to case and junction to ambient versus pulse duration.

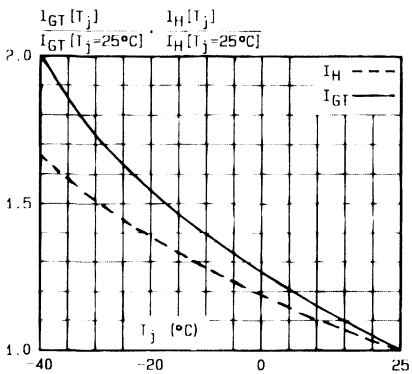

Fig.5 - Relative variation of gate trigger current and holding current versus junction temperature.

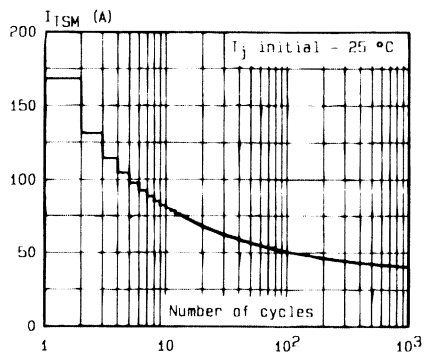

Fig.6 - Non repetitive surge peak on-state current versus number of cycles.

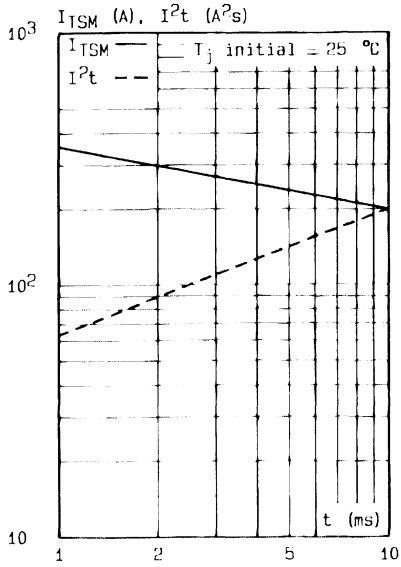

Fig.7 - Non repetitive surge peak on-state current for a sinusoidal pulse with width :  $t \leq 10$  ms, and corresponding value of  $I^2t$ .

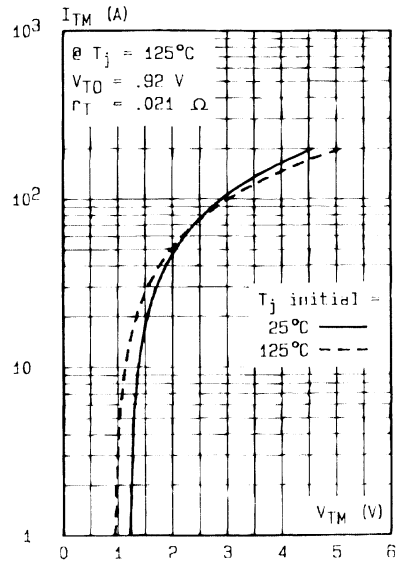

Fig.8 - Un-state characteristics (maximum values).

**TRIACS**

- GLASS PASSIVATED CHIP
- $I_{GT}$  SPECIFIED IN FOUR QUADRANTS

**DESCRIPTION**

This new design of plastic uninsulated power triacs offers maximum efficiency with maximum ease of mounting.

**ADVANTAGES**

- NO TAPPING REQUIRED FOR FIXING
- EXCELLENT THERMAL IMPEDANCE AND HIGH RELIABILITY CONSTRUCTION

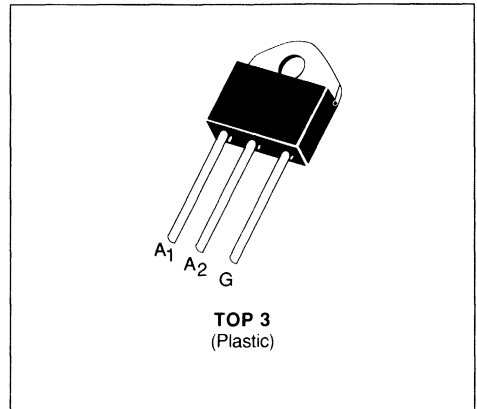
**ABSOLUTE RATINGS** (limiting values)

Symbol	Parameter	Value	Unit
$I_{T(RMS)}$	RMS on-state Current (360° conduction angle) $T_C = 90\text{ }^\circ\text{C}$	30	A
$I_{TSM}$	Non Repetitive Surge Peak on-state Current ( $T_j$ initial = 25 °C - Half sine wave)	$t = 8.3\text{ ms}$	260
		$t = 10\text{ ms}$	250
$I^2t$	$I^2t$ Value for Fusing $t = 10\text{ ms}$	312.5	A <sup>2</sup> s
$di/dt$	Critical Rate of Rise of on-state Current (1)	Repetitive $F = 50\text{ Hz}$	10
		Non Repetitive	50
$T_{stg}$ $T_j$	Storage and Operating Junction Temperature Range	- 40 to 125	°C
		- 40 to 125	°C

Symbol	Parameter	BTB 26-					Unit
		200A	400A	600A	700A	800A	
$V_{DRM}$	Repetitive Peak off-state Voltage (2)	200	400	600	700	800	V

(1)  $I_G = 1.5\text{ A}$   $di/dt = 1\text{ A}/\mu\text{s}$

(2)  $T_j = 125\text{ }^\circ\text{C}$ .

**THERMAL RESISTANCES**

Symbol	Parameter	Value	Unit
$R_{th(j-a)}$	Junction to Ambient	50	°C/W
$R_{th(c-h)}$	Contact (case-heatsink) with Grease	0.2	°C/W
$R_{th(j-c)}\text{ DC}$	Junction to Case for DC	1.2	°C/W
$R_{th(j-c)}\text{ AC}$	Junction to Case for 360 ° Conduction Angle ( $F = 50\text{ Hz}$ )	0.9	°C/W

**GATE CHARACTERISTICS** (maximum values)

$P_{GM} = 40 \text{ W}$  ( $t_p = 10 \mu\text{s}$ )

$I_{GM} = 6 \text{ A}$  ( $t_p = 10 \mu\text{s}$ )

$P_{G(AV)} = 1 \text{ W}$

$V_{GM} = 16 \text{ V}$  ( $t_p = 10 \mu\text{s}$ )

**ELECTRICAL CHARACTERISTICS**

Symbol	Test Conditions			Quadrants	Min.	Typ.	Max.	Unit
$I_{GT}$	$T_j = 25 \text{ }^\circ\text{C}$ Pulse Duration > 20 $\mu\text{s}$	$V_D = 12 \text{ V}$	$R_L = 33 \text{ } \Omega$	I-II-III	1		100	mA
				IV	1		150	
$V_{GT}$	$T_j = 25 \text{ }^\circ\text{C}$ Pulse Duration > 20 $\mu\text{s}$	$V_D = 12 \text{ V}$	$R_L = 33 \text{ } \Omega$	I-II-III-IV			1.5	V
$V_{GD}$	$T_j = 125 \text{ }^\circ\text{C}$	$V_D = V_{DRM}$	$R_L = 3.3 \text{ k}\Omega$	I-II-III-IV	0.2			V
$I_{H^*}$	$T_j = 25 \text{ }^\circ\text{C}$	$I_T = 500 \text{ mA}$	Gate Open			30	100	mA
$I_L$	$T_j = 25 \text{ }^\circ\text{C}$ Pulse Duration > 20 $\mu\text{s}$	$V_D = 12 \text{ V}$	$I_G = 300 \text{ mA}$	I-II-III-IV			150	mA
$V_{TM^*}$	$T_j = 25 \text{ }^\circ\text{C}$	$I_{TM} = 35 \text{ A}$	$t_p = 10 \text{ ms}$				1.7	V
$I_{DRM^*}$	$T_j = 125 \text{ }^\circ\text{C}$	$V_{DRM}$ Specified				1.5	6	mA
$dv/dt^*$	$T_j = 125 \text{ }^\circ\text{C}$	Gate Open			250			V/ $\mu\text{s}$
$(dv/dt)_c^*$	$T_c = 90 \text{ }^\circ\text{C}$ $(di/dt)_c = 13.3 \text{ A/ms}$	$V_D = V_{DRM}$	$I_T = 35 \text{ A}$		10			V/ $\mu\text{s}$
$t_{gt}$	$T_j = 25 \text{ }^\circ\text{C}$ $I_G = 1 \text{ A}$	$V_D = V_{DRM}$ $di_G/dt = 10 \text{ A}/\mu\text{s}$	$I_T = 35 \text{ A}$	I-II-III-IV		2.5		$\mu\text{s}$

\* For either polarity of electrode  $A_2$  voltage with reference to electrode  $A_1$ .

**PACKAGE MECHANICAL DATA**

TOP 3 Plastic

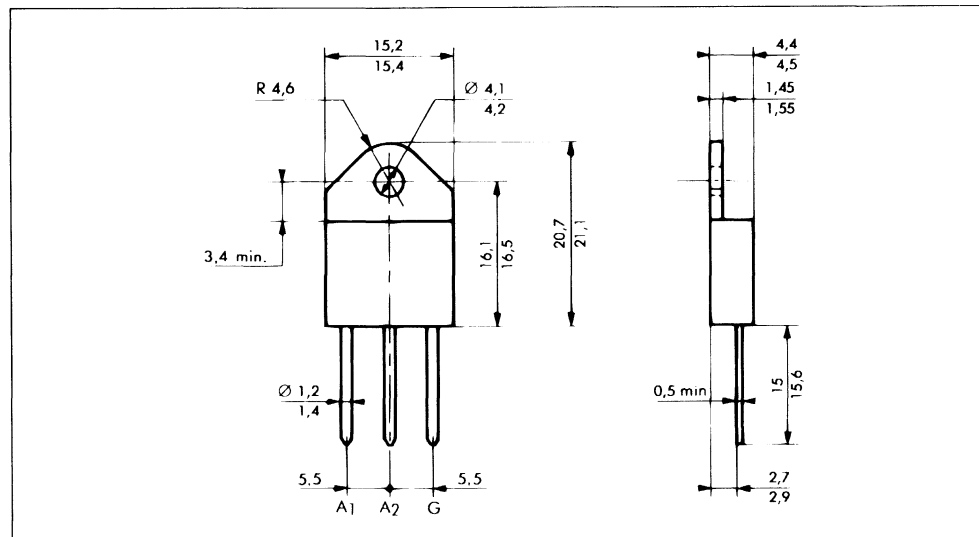

Cooling method : by conduction (method C)

Marking : type number

Weight : 5 g

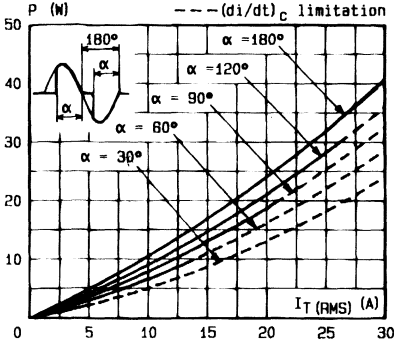

Fig. 1 - Maximum mean power dissipation versus RMS on-state current ( $F = 60 \text{ Hz}$ ).

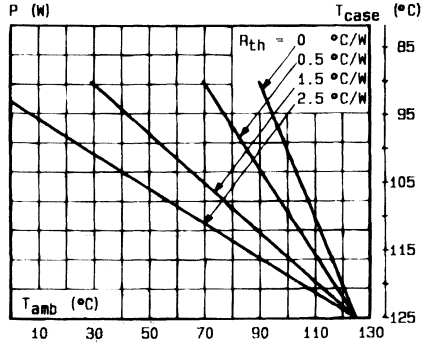

Fig. 2 - Correlation between maximum mean power dissipation and maximum allowable temperatures ( $T_{amb}$  and  $T_{case}$ ) for different thermal resistances heatsink + contact.

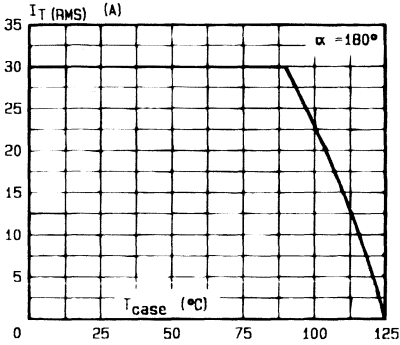

Fig. 3 - RMS on-state current versus case temperature.

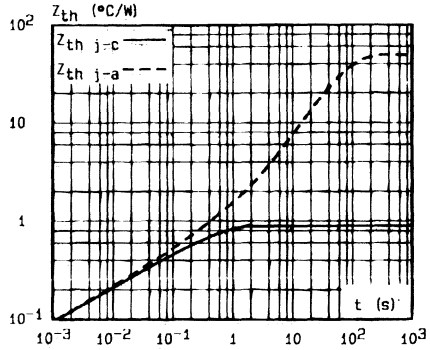

Fig. 4 - Thermal transient impedance junction to case and junction to ambient versus pulse duration.

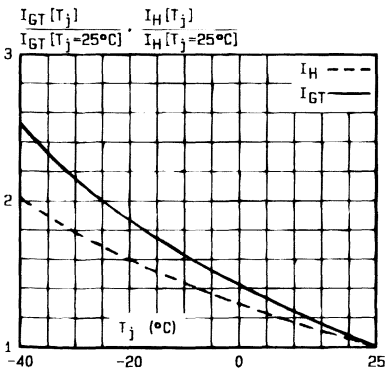

Fig. 5 - Relative variation of gate trigger current and holding current versus junction temperature.

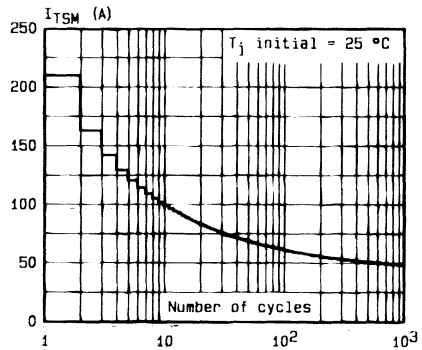

Fig. 6 - Non repetitive surge peak on-state current versus number of cycles.

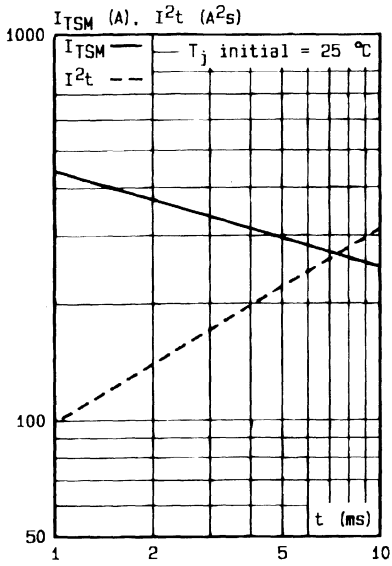

Fig.7 - Non repetitive surge peak on-state current for a sinusoidal pulse with width :  $t \leq 10$  ms, and corresponding value of  $I^2t$ .

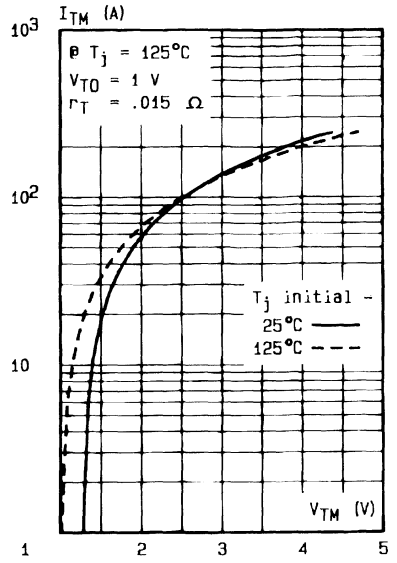

Fig.8 - On-state characteristics (maximum values).



**TRIACS**

- GLASS PASSIVATED CHIP
- $I_{GT}$  SPECIFIED IN FOUR QUADRANTS

**DESCRIPTION**

This new design of plastic uninsulated power triacs offers maximum efficiency with maximum ease of mounting.

**ADVANTAGES**

- NO TAPPING REQUIRED FOR FIXING
- EXCELLENT THERMAL IMPEDANCE AND HIGH RELIABILITY CONSTRUCTION

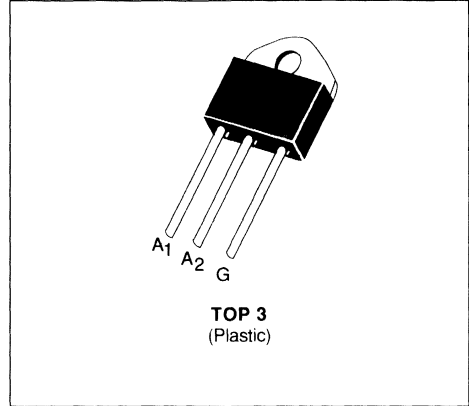
**ABSOLUTE RATINGS** (limiting values)

Symbol	Parameter		Value	Unit
$I_{T(RMS)}$	RMS on-state Current (360° conduction angle)	$T_C = 90^\circ C$	30	A
$I_{TSM}$	Non Repetitive Surge Peak on-state Current ( $T_J$ initial = 25 °C - Half sine wave)	$t = 8.3$ ms	260	A
		$t = 10$ ms	250	
$I^2t$	$I^2t$ Value for Fusing	$t = 10$ ms	312.5	A <sup>2</sup> s
di/dt	Critical Rate of Rise of on-state Current (1)	Repetitive F = 50 Hz	10	A/μs
		Non Repetitive	50	
$T_{stg}$ $T_J$	Storage and Operating Junction Temperature Range		- 40 to 125 - 40 to 125	°C °C

Symbol	Parameter	BTB 26-					Unit
		200B	400B	600B	700B	800B	
$V_{DRM}$	Repetitive Peak off-state Voltage (2)	200	400	600	700	800	V

(1)  $I_G = 1$  A  $di/dt = 1$  A/μs

(2)  $T_J = 125^\circ C$ .

**THERMAL RESISTANCES**

Symbol	Parameter	Value	Unit
$R_{th(j-a)}$	Junction to Ambient	50	°C/W
$R_{th(j-c-h)}$	Contact (case-heatsink) with Grease	0.2	°C/W
$R_{th(j-c)} DC$	Junction to Case for DC	1.2	°C/W
$R_{th(j-c)} AC$	Junction to Case for 360 ° Conduction Angle (F = 50 Hz)	0.9	°C/W

**GATE CHARACTERISTICS** (maximum values)

$P_{GM} = 40 \text{ W}$  ( $t_p = 10 \mu\text{s}$ )       $I_{GM} = 6 \text{ A}$  ( $t_p = 10 \mu\text{s}$ )  
 $P_{G(AV)} = 1 \text{ W}$        $V_{GM} = 16 \text{ V}$  ( $t_p = 10 \mu\text{s}$ )

**ELECTRICAL CHARACTERISTICS**

Symbol	Test Conditions	Quadrants	Min.	Typ.	Max.	Unit
$I_{GT}$	$T_j = 25 \text{ }^\circ\text{C}$ $V_D = 12 \text{ V}$ $R_L = 33 \text{ }\Omega$ Pulse Duration > 20 $\mu\text{s}$	I-II-III	1		50	mA
		IV	1		100	
$V_{GT}$	$T_j = 25 \text{ }^\circ\text{C}$ $V_D = 12 \text{ V}$ $R_L = 33 \text{ }\Omega$ Pulse Duration > 20 $\mu\text{s}$	I-II-III-IV			1.5	V
$V_{GD}$	$T_j = 125 \text{ }^\circ\text{C}$ $V_D = V_{DRM}$ $R_L = 3.3 \text{ k}\Omega$	I-II-III-IV	0.2			V
$I_{H^*}$	$T_j = 25 \text{ }^\circ\text{C}$ $I_T = 500 \text{ mA}$ Gate Open			30	80	mA
$I_L$	$T_j = 25 \text{ }^\circ\text{C}$ $V_D = 12 \text{ V}$ $I_G = 200 \text{ mA}$ Pulse Duration > 20 $\mu\text{s}$	I-II-III-IV			100	mA
$V_{TM^*}$	$T_j = 25 \text{ }^\circ\text{C}$ $I_{TM} = 35 \text{ A}$ $t_p = 10 \text{ ms}$				1.7	V
$I_{DRM^*}$	$T_j = 125 \text{ }^\circ\text{C}$ $V_{DRM}$ Specified			1.5	6	mA
dv/dt*	$T_j = 125 \text{ }^\circ\text{C}$ Gate Open Linear Slope up to $V_D = 67\% V_{DRM}$		250			V/ $\mu\text{s}$
(dv/dt) <sub>c</sub> *	$T_c = 90 \text{ }^\circ\text{C}$ $V_D = V_{DRM}$ $I_T = 35 \text{ A}$ (di/dt) <sub>c</sub> = 13.3 A/ms		5			V/ $\mu\text{s}$
t <sub>gt</sub>	$T_j = 25 \text{ }^\circ\text{C}$ $V_D = V_{DRM}$ $I_T = 35 \text{ A}$ $I_G = 1 \text{ A}$ di <sub>G</sub> /dt = 10 A/ $\mu\text{s}$	I-II-III-IV		2.5		$\mu\text{s}$

\* For either polarity of electrode A<sub>2</sub> voltage with reference to electrode A<sub>1</sub>.

**PACKAGE MECHANICAL DATA**

TOP 3 Plastic

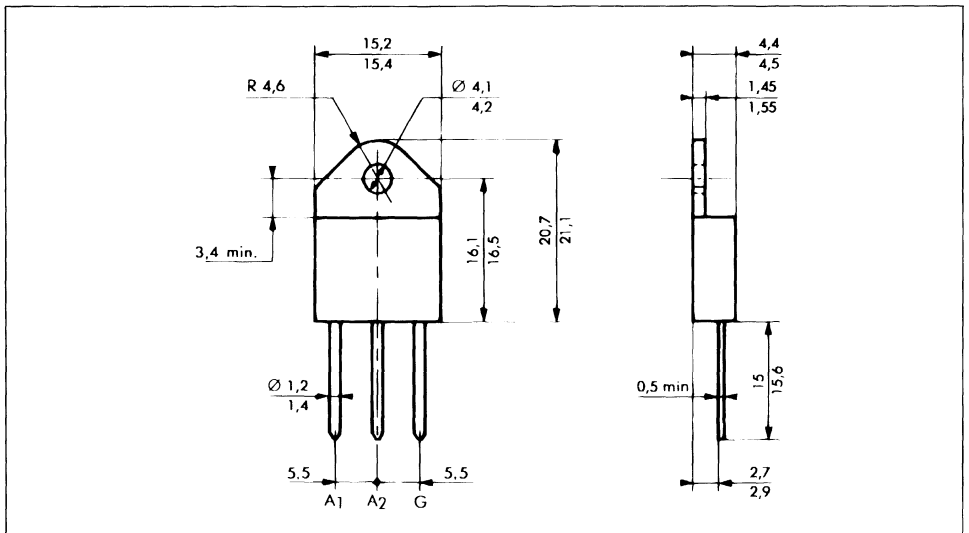

Cooling method : by conduction (method C)  
 Marking : type number  
 Weight : 5 g

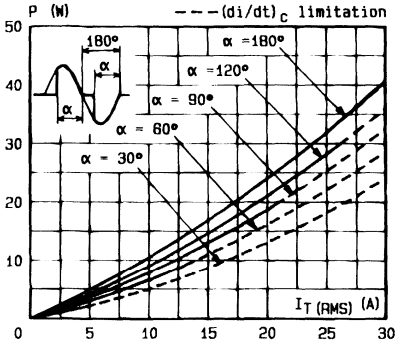

Fig. 1 - Maximum mean power dissipation versus RMS on-state current (F = 60 Hz).

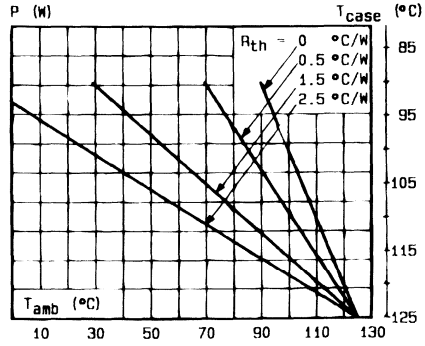

Fig. 2 - Correlation between maximum mean power dissipation and maximum allowable temperatures (T<sub>amb</sub> and T<sub>case</sub>) for different thermal resistances heatsink + contact.

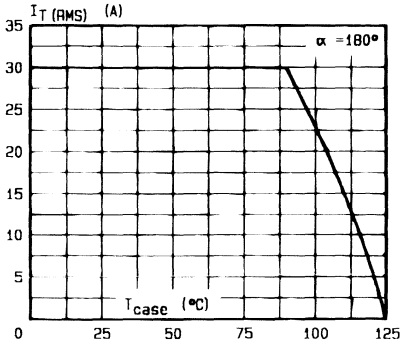

Fig. 3 - RMS on-state current versus case temperature.

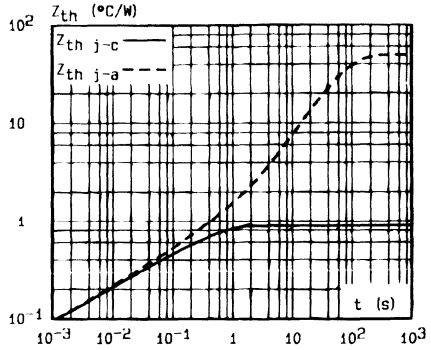

Fig. 4 - Thermal transient impedance junction to case and junction to ambient versus pulse duration.

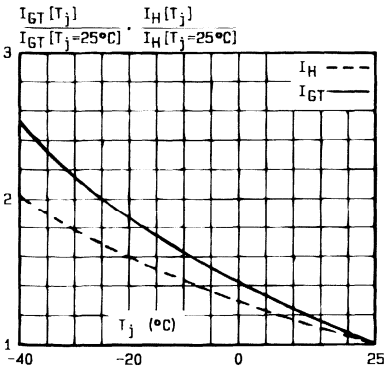

Fig. 5 - Relative variation of gate trigger current and holding current versus junction temperature.

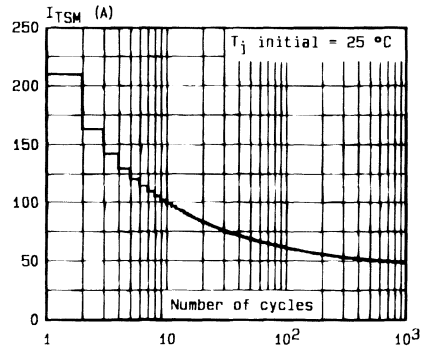

Fig. 6 - Non repetitive surge peak on-state current versus number of cycles.

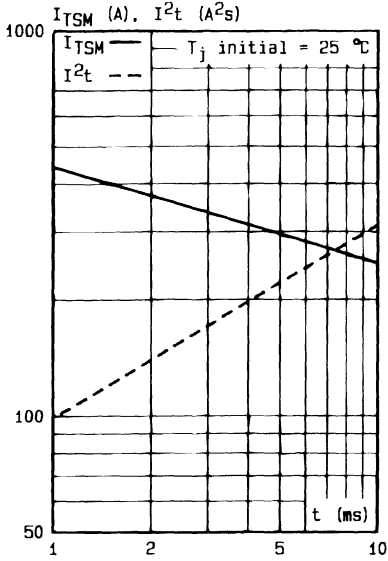

Fig.7 - Non repetitive surge peak on-state current for a sinusoidal pulse with width :  $t \leq 10$  ms, and corresponding value of  $I^2t$ .

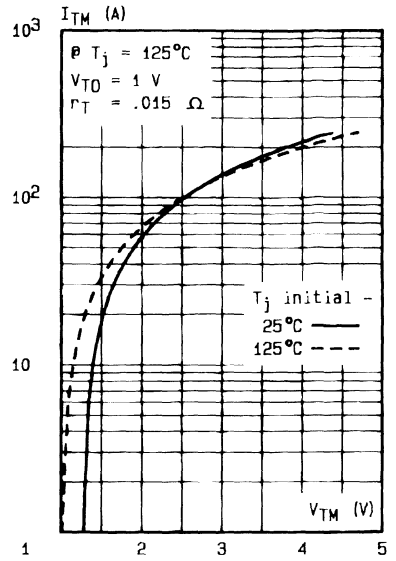

Fig.8 - On-state characteristics (maximum values).

**TRIACS**

- GLASS PASSIVATED CHIP
- $I_{GT}$  SPECIFIED IN FOUR QUADRANTS

**DESCRIPTION**

This new design of plastic uninsulated power triacs offers maximum efficiency with maximum ease of mounting.

**ADVANTAGES**

- NO TAPPING REQUIRED FOR FIXING
- EXCELLENT THERMAL IMPEDANCE AND HIGH RELIABILITY CONSTRUCTION

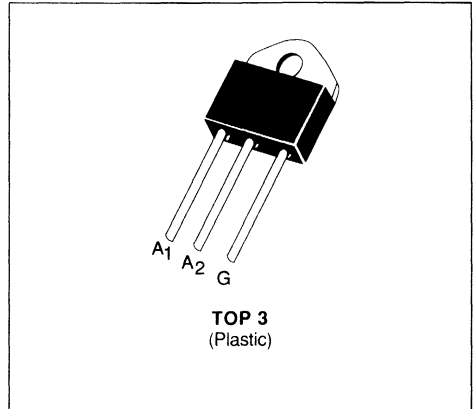
**ABSOLUTE RATINGS** (limiting values)

Symbol	Parameter	Value	Unit
$I_{T(RMS)}$	RMS on-state Current (360° conduction angle) $T_C = 80\text{ }^\circ\text{C}$	45	A
$I_{TSM}$	Non Repetitive Surge Peak on-state Current ( $T_j$ initial = 25 °C - Half sine wave)	$t = 8.3\text{ ms}$	315
		$t = 10\text{ ms}$	300
$I^2t$	$I^2t$ Value for Fusing $t = 10\text{ ms}$	450	A <sup>2</sup> s
di/dt	Critical Rate of Rise of on-state Current (1)	Repetitive $F = 50\text{ Hz}$	10
		Non Repetitive	50
$T_{stg}$ $T_j$	Storage and Operating Junction Temperature Range	- 40 to 125	°C
		- 40 to 125	°C

Symbol	Parameter	BTB 41-					Unit
		200A	400A	600A	700A	800A	
$V_{DRM}$	Repetitive Peak off-state Voltage (2)	200	400	600	700	800	V

(1)  $I_G = 1.5\text{ A}$      $di_G/dt = 1\text{ A}/\mu\text{s}$

(2)  $T_j = 125\text{ }^\circ\text{C}$ .

**THERMAL RESISTANCES**

Symbol	Parameter	Value	Unit
$R_{th(j-a)}$	Junction to Ambient	50	°C/W
$R_{th(c-h)}$	Contact (case-heatsink) with Grease	0.2	°C/W
$R_{th(j-c)}\text{ DC}$	Junction to Case for DC	0.95	°C/W
$R_{th(j-c)}\text{ AC}$	Junction to Case for 360 ° Conduction Angle ( $F = 50\text{ Hz}$ )	0.7	°C/W

**GATE CHARACTERISTICS** (maximum values)

$P_{GM} = 40 \text{ W}$  ( $t_p = 10 \mu\text{s}$ )       $I_{GM} = 10 \text{ A}$  ( $t_p = 10 \mu\text{s}$ )  
 $P_{G(AV)} = 1 \text{ W}$        $V_{GM} = 16 \text{ V}$  ( $t_p = 10 \mu\text{s}$ )

**ELECTRICAL CHARACTERISTICS**

Symbol	Test Conditions	Quadrants	Min.	Typ.	Max.	Unit
$I_{GT}$	$T_j = 25 \text{ }^\circ\text{C}$ $V_D = 12 \text{ V}$ $R_L = 33 \text{ } \Omega$ Pulse Duration > 20 $\mu\text{s}$	I-II-III	1		100	mA
		IV	1		150	
$V_{GT}$	$T_j = 25 \text{ }^\circ\text{C}$ $V_D = 12 \text{ V}$ $R_L = 33 \text{ } \Omega$ Pulse Duration > 20 $\mu\text{s}$	I-II-III-IV			1.5	V
$V_{GD}$	$T_j = 125 \text{ }^\circ\text{C}$ $V_D = V_{DRM}$ $R_L = 3.3 \text{ k}\Omega$	I-II-III-IV	0.2			V
$I_H^*$	$T_j = 25 \text{ }^\circ\text{C}$ $I_T = 500 \text{ mA}$ Gate Open			30	100	mA
$I_L$	$T_j = 25 \text{ }^\circ\text{C}$ $V_D = 12 \text{ V}$ $I_G = 300 \text{ mA}$ Pulse Duration > 20 $\mu\text{s}$	I-II-III-IV			150	mA
$V_{TM}^*$	$T_j = 25 \text{ }^\circ\text{C}$ $I_{TM} = 60 \text{ A}$ $t_p = 10 \text{ ms}$				1.8	V
$I_{DRM}^*$	$T_j = 125 \text{ }^\circ\text{C}$ $V_{DRM}$ Specified			1.5	6	mA
$dv/dt^*$	$T_j = 125 \text{ }^\circ\text{C}$ Gate Open Linear Slope up to $V_D = 67 \% V_{DRM}$		250			V/ $\mu\text{s}$
$(dv/dt)_c^*$	$T_C = 75 \text{ }^\circ\text{C}$ $V_D = V_{DRM}$ $I_T = 60 \text{ A}$ $(di/dt)_c = 20 \text{ A/ms}$		10			V/ $\mu\text{s}$
$t_{gt}$	$T_j = 25 \text{ }^\circ\text{C}$ $V_D = V_{DRM}$ $I_T = 60 \text{ A}$ $I_G = 1 \text{ A}$ $di_G/dt = 10 \text{ A}/\mu\text{s}$	I-II-III-IV		2.5		$\mu\text{s}$

\* For either polarity of electrode  $A_2$  voltage with reference to electrode  $A_1$ .

**PACKAGE MECHANICAL DATA**

TOP 3 Plastic

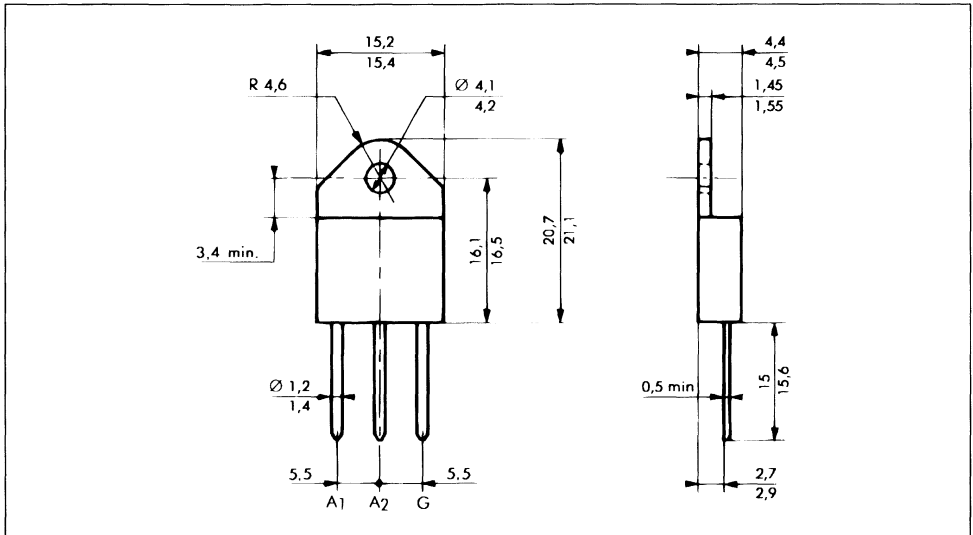

Cooling method : by conduction (method C)

Marking : type number

Weight : 5 g

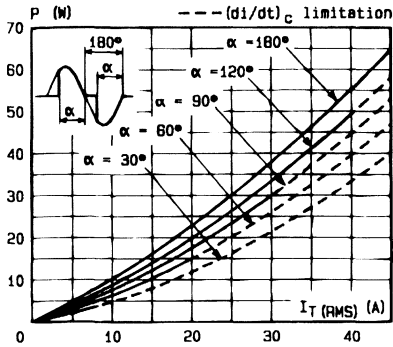

Fig.1 - Maximum mean power dissipation versus RMS on-state current ( $f = 60 \text{ Hz}$ ).

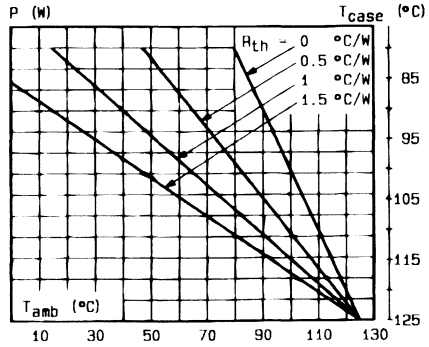

Fig.2 - Correlation between maximum mean power dissipation and maximum allowable temperatures ( $T_{amb}$  and  $T_{case}$ ) for different thermal resistances heatsink + contact.

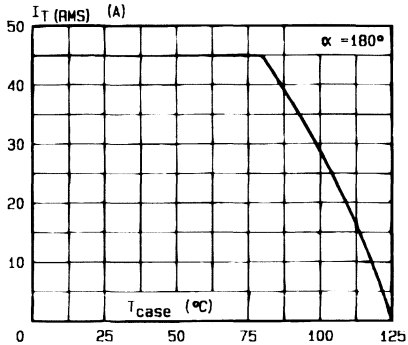

Fig.3 - RMS on-state current versus case temperature.

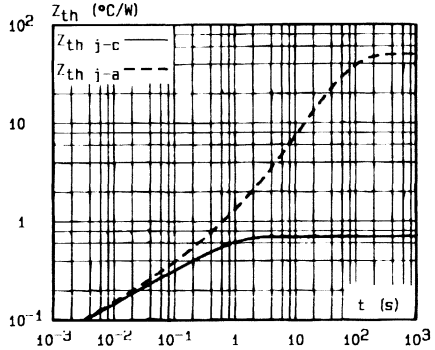

Fig.4 - Thermal transient impedance junction to case and junction to ambient versus pulse duration.

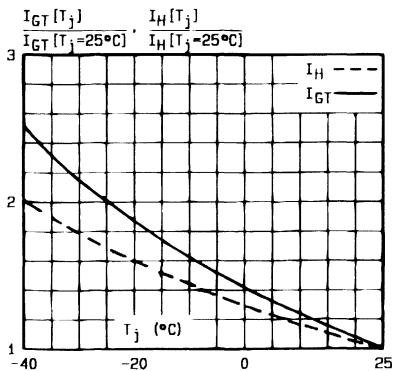

Fig.5 - Relative variation of gate trigger current and holding current versus junction temperature.

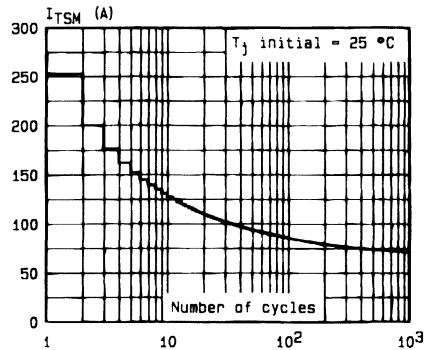

Fig.6 - Non repetitive surge peak on-state current versus number of cycles.

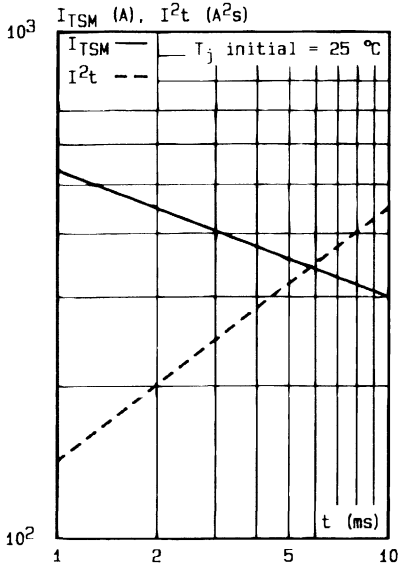

Fig.7 - Non repetitive surge peak on-state current for a sinusoidal pulse with width :  $t \leq 10$  ms, and corresponding value of  $I^2t$ .

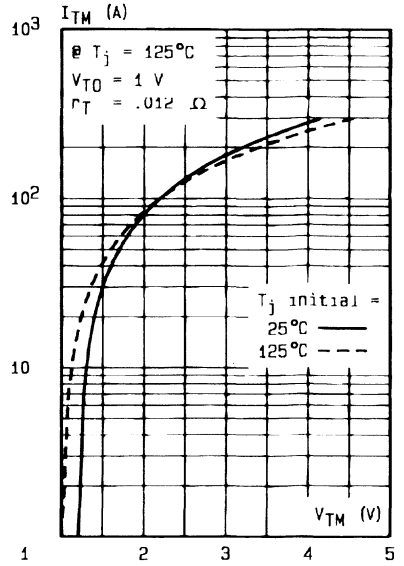

Fig.8 - On-state characteristics (maximum values).



**TRIACS**

- GLASS PASSIVATED CHIP
- $I_{GT}$  SPECIFIED IN FOUR QUADRANTS

**DESCRIPTION**

This new design of plastic uninsulated power triacs offers maximum efficiency with maximum ease of mounting.

**ADVANTAGES**

- NO TAPPING REQUIRED FOR FIXING
- EXCELLENT THERMAL IMPEDANCE AND HIGH RELIABILITY CONSTRUCTION

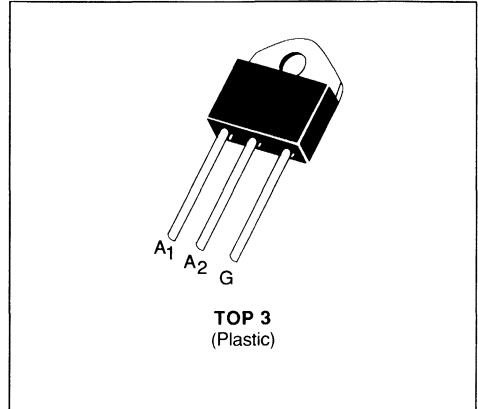
**ABSOLUTE RATINGS** (limiting values)

Symbol	Parameter		Value	Unit
$I_{T(RMS)}$	RMS on-state Current (360° conduction angle)	$T_C = 80^\circ C$	45	A
$I_{ISM}$	Non Repetitive Surge Peak on-state Current ( $T_J$ initial = 25 °C - Half sine wave)	$t = 8.3$ ms	315	A
		$t = 10$ ms	300	
$I^2t$	$I^2t$ Value for Fusing	$t = 10$ ms	450	A <sup>2</sup> s
di/dt	Critical Rate of Rise of on-state Current (1)	Repetitive F = 50 Hz	10	A/ $\mu$ s
		Non Repetitive	50	
$T_{stg}$ $T_J$	Storage and Operating Junction Temperature Range		- 40 to 125 - 40 to 125	°C °C

Symbol	Parameter	BTB 41 -					Unit
		200B	400B	600B	700B	800B	
$V_{DRM}$	Repetitive Peak off-state Voltage (2)	200	400	600	700	800	V

(1)  $I_G = 1$  A  $di_G/dt = 1$  A/ $\mu$ s

(2)  $T_J = 125^\circ C$ .

**THERMAL RESISTANCES**

Symbol	Parameter	Value	Unit
$R_{th(j-a)}$	Junction to Ambient	50	°C/W
$R_{th(c-h)}$	Contact (case-heatsink) with Grease	0.2	°C/W
$R_{th(j-c)}$ DC	Junction to Case for DC	0.95	°C/W
$R_{th(j-c)}$ AC	Junction to Case for 360° Conduction Angle (F = 50 Hz)	0.7	°C/W

**GATE CHARACTERISTICS** (maximum values)

$P_{GM} = 40 \text{ W}$  ( $t_p = 10 \mu\text{s}$ )       $I_{GM} = 10 \text{ A}$  ( $t_p = 10 \mu\text{s}$ )

$P_{G(AV)} = 1 \text{ W}$        $V_{GM} = 16 \text{ V}$  ( $t_p = 10 \mu\text{s}$ )

**ELECTRICAL CHARACTERISTICS**

Symbol	Test Conditions			Quadrants	Min.	Typ.	Max.	Unit
$I_{GT}$	$T_j = 25 \text{ }^\circ\text{C}$ Pulse Duration > 20 $\mu\text{s}$	$V_D = 12 \text{ V}$	$R_L = 33 \text{ }\Omega$	I-II-III	1		50	mA
				IV	1		100	
$V_{GT}$	$T_j = 25 \text{ }^\circ\text{C}$ Pulse Duration > 20 $\mu\text{s}$	$V_D = 12 \text{ V}$	$R_L = 33 \text{ }\Omega$	I-II-III-IV			1.5	V
$V_{GD}$	$T_j = 125 \text{ }^\circ\text{C}$	$V_D = V_{DRM}$	$R_L = 3.3 \text{ k}\Omega$	I-II-III-IV	0.2			V
$I_{H^*}$	$T_j = 25 \text{ }^\circ\text{C}$	$I_T = 500 \text{ mA}$	Gate Open			30	80	mA
$I_L$	$T_j = 25 \text{ }^\circ\text{C}$ Pulse Duration > 20 $\mu\text{s}$	$V_D = 12 \text{ V}$	$I_G = 200 \text{ mA}$	I-II-III-IV			100	mA
$V_{TM}^*$	$T_j = 25 \text{ }^\circ\text{C}$	$I_{TM} = 60 \text{ A}$	$t_p = 10 \text{ ms}$				1.8	V
$I_{DRM}^*$	$T_j = 125 \text{ }^\circ\text{C}$	$V_{DRM}$ Specified				1.5	6	mA
$dv/dt^*$	$T_j = 125 \text{ }^\circ\text{C}$	Gate Open			250			V/ $\mu\text{s}$
$(dv/dt)_c^*$	$T_C = 75 \text{ }^\circ\text{C}$	$V_D = V_{DRM}$	$I_T = 60 \text{ A}$ $(di/dt)_c = 20 \text{ A/ms}$		5			V/ $\mu\text{s}$
$t_{gt}$	$T_j = 25 \text{ }^\circ\text{C}$	$V_D = V_{DRM}$	$I_T = 60 \text{ A}$ $I_G = 1 \text{ A}$ $di_G/dt = 10 \text{ A}/\mu\text{s}$	I-II-III-IV		2.5		$\mu\text{s}$

\* For either polarity of electrode A<sub>2</sub> voltage with reference to electrode A<sub>1</sub>.

**PACKAGE MECHANICAL DATA**

TOP 3 Plastic

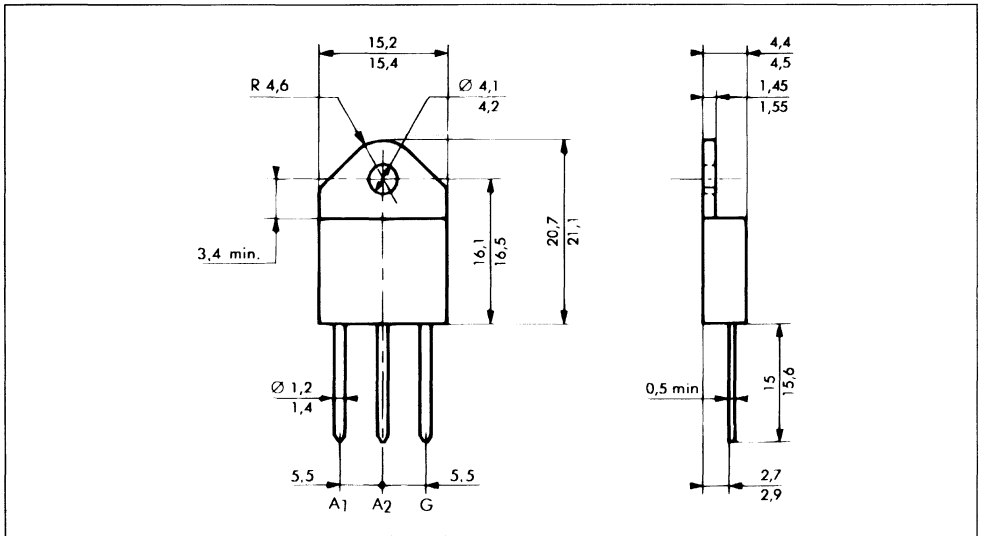

Cooling method : by conduction (method C)

Marking : type number

Weight : 5 g

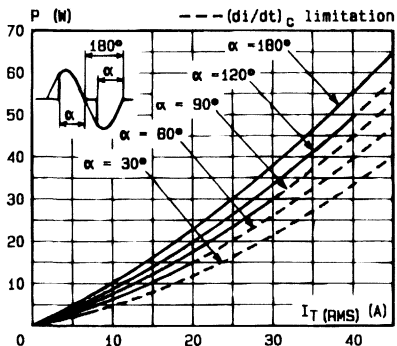

Fig.1 - Maximum mean power dissipation versus RMS on-state current ( $f = 60 \text{ Hz}$ ).

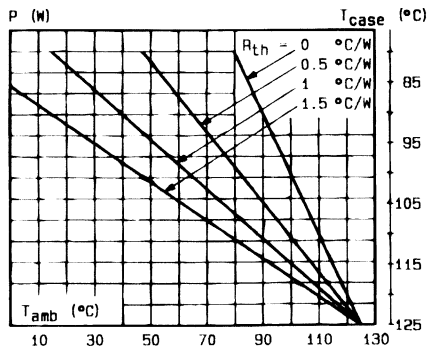

Fig.2 - Correlation between maximum mean power dissipation and maximum allowable temperatures ( $T_{amb}$  and  $T_{case}$ ) for different thermal resistances heatsink + contact.

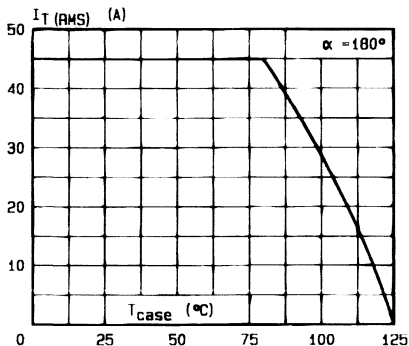

Fig.3 - RMS on-state current versus case temperature.

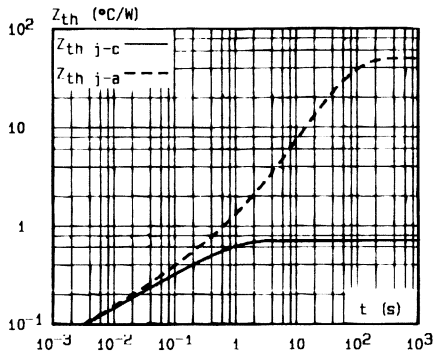

Fig.4 - Thermal transient impedance junction to case and junction to ambient versus pulse duration.

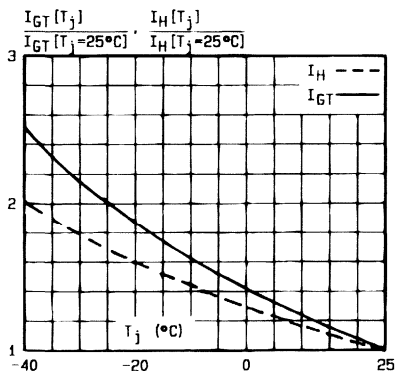

Fig.5 - Relative variation of gate trigger current and holding current versus junction temperature.

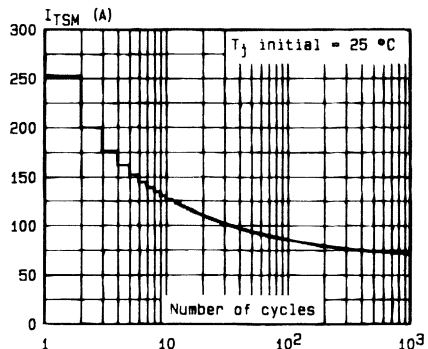

Fig.6 - Non repetitive surge peak on-state current versus number of cycles.

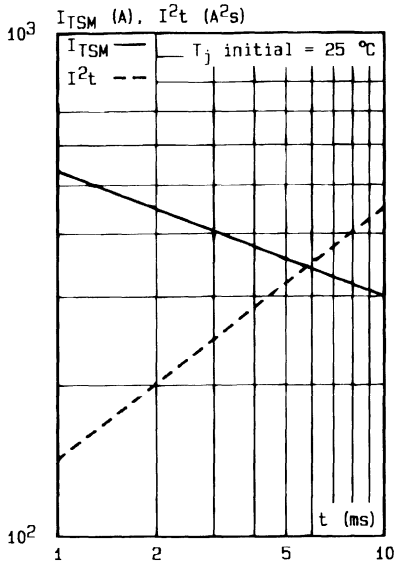

Fig.7 - Non repetitive surge peak on-state current for a sinusoidal pulse with width :  $t \leq 10$  ms, and corresponding value of  $I^2t$ .

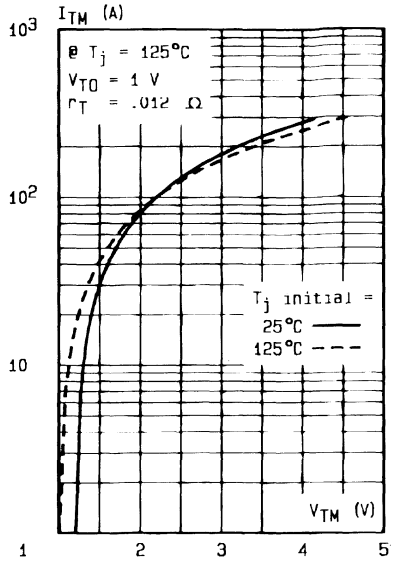

Fig.8 - On-state characteristics (maximum values).

**TRIGGER DIODES**

**APPLICATIONS**

Thyristors and triacs triggering.

**ADVANTAGES**

High reliability glass passivation insuring parameter stability and protection against junction contamination

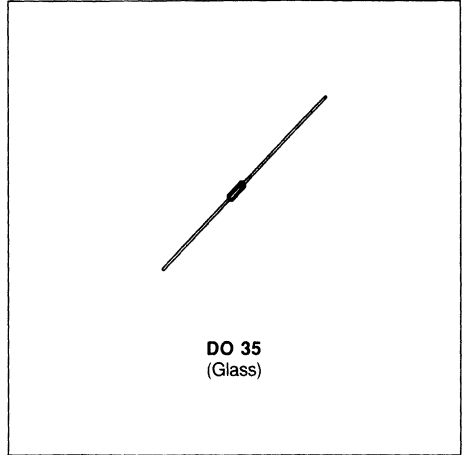

**ABSOLUTE RATINGS (limiting values)**

Symbol	Parameter	Value	Unit
P	Power Dissipation on Printed Circuit (L = 10 mm) $T_a = 50\text{ }^\circ\text{C}$	150	mW
$I_{TRM}$	Repetitive Peak on-state Current $t_p = 20\text{ }\mu\text{s}$ $F = 100\text{ Hz}$	2	A
$T_{stg}$ $T_j$	Storage and Operating Junction Temperature Range	- 40 to 125 - 40 to 110	$^\circ\text{C}$ $^\circ\text{C}$

**THERMAL RESISTANCES**

Symbol	Parameter	Value	Unit
$R_{th(j-a)}$	Junction-ambient	400	$^\circ\text{C/W}$
$R_{th(j-l)}$	Junction-leads	150	$^\circ\text{C/W}$

**ELECTRICAL CHARACTERISTICS** ( $T_j = 25\text{ }^\circ\text{C}$ )

Symbol	Parameter	Test Conditions	Types	Min.	Typ.	Max.	Unit
$V_{BO}$	Breakover Voltage*	C = 22 nF** See diagram 1	DB3	28	32	36	V
			DB4	35	40	45	
$[ +V_{BO}  -  -V_{BO} ]$	Breakover Voltage Symmetry	C = 22 nF** See diagram 1				$\pm 3$	V
$ \Delta V_{\pm} $	Dynamic Breakback Voltage*	$\Delta I = [I_{BO} \text{ to } I_F = 10\text{ mA}]$ See diagram 1		5			V
$V_O$	Output Voltage*	See diagram 2		5			V
$I_{BO}$	Breakover Current*	C = 22 nF**				100	$\mu\text{A}$
$t_r$	Rise Time*	See diagram 3			1.5		$\mu\text{s}$
$I_B$	Leakage Current*	$V_B = 0.5 V_{BO} \text{ max}$ See diagram 1				10	$\mu\text{A}$

\* Electrical characteristic applicable in both forward and reverse directions.  
 \*\* Connected in parallel with the device.

**DIAGRAM 1 : Current-voltage characteristics.**

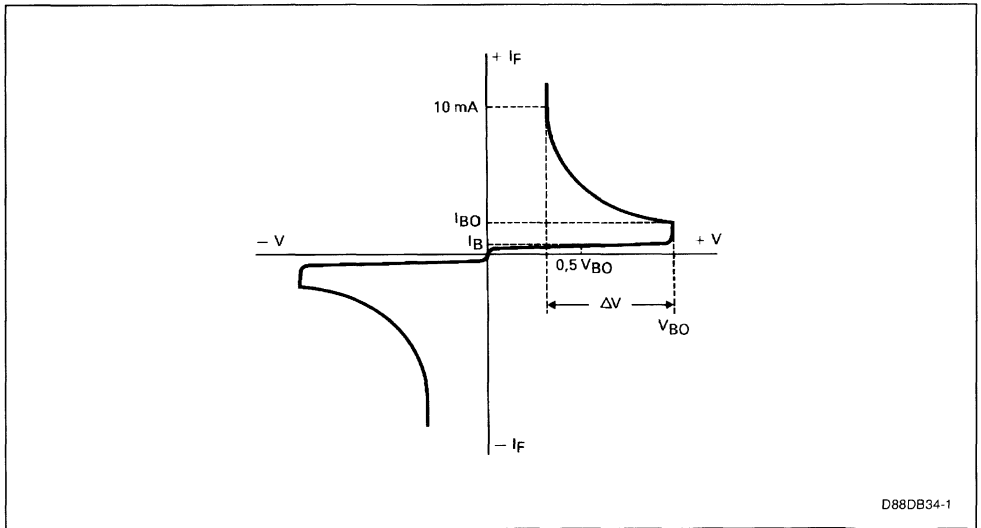

D88DB34-1

**DIAGRAM 2 : Test circuit for output voltage.**

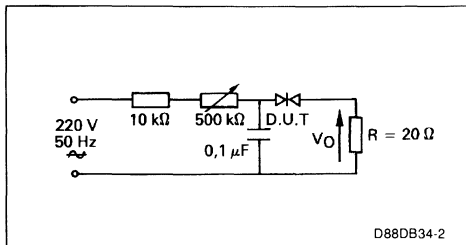

D88DB34-2

**DIAGRAM 3 : Test circuit see diagram 2.  
Adjust R for  $I_p = 0.5\text{ A}$ .**

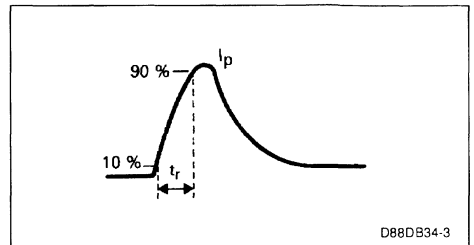

D88DB34-3

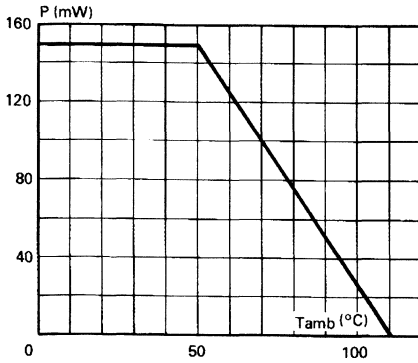

Fig. 1 - Power dissipation versus ambient temperature (maximum values).

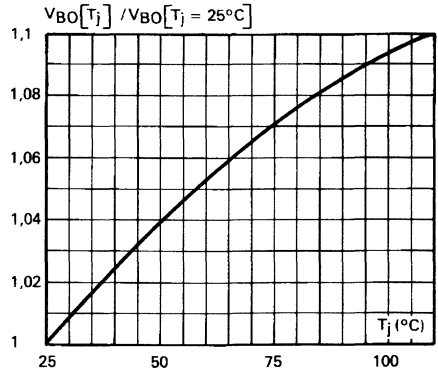

Fig. 2 - Relative variation of VBO versus junction temperature (typical values).

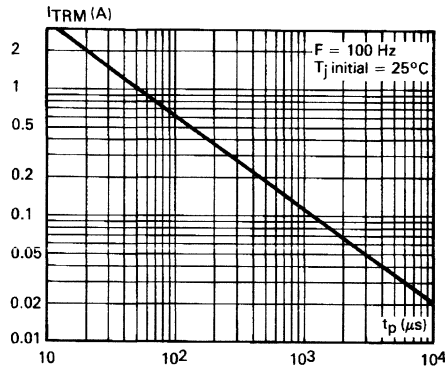
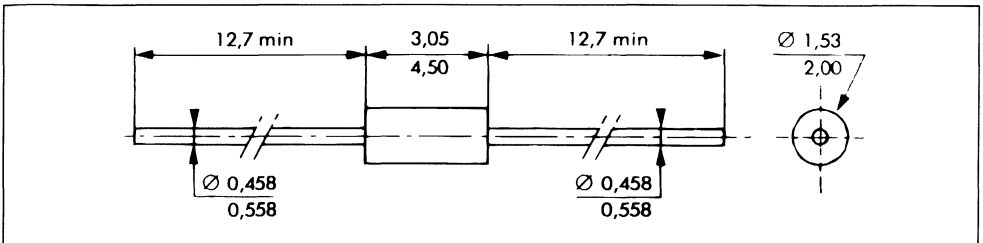

Fig. 3 - Peak pulse current versus pulse duration (maximum values).

**PACKAGE MECHANICAL DATA**

DO 35 Glass



Weight : 0.15 g.  
 Marking : clear.





**TRIGGER DIODES**
**APPLICATIONS**

Thyristors and triacs triggering.

**ADVANTAGES**

High reliability glass passivation insuring parameter stability and protection against junction contamination

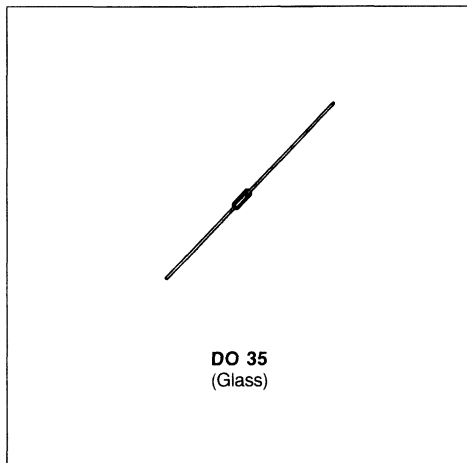
**ABSOLUTE RATINGS** (limiting values)

Symbol	Parameter		Value	Unit
P	Power Dissipation on Printed Circuit (L = 10 mm)	T <sub>a</sub> = 50 °C	150	mW
I <sub>TRM</sub>	Repetitive Peak on-state Current	t <sub>p</sub> = 20 μs F = 100 Hz	2	A
T <sub>stg</sub> T <sub>j</sub>	Storage and Operating Junction Temperature Range		- 40 to 125 - 40 to 110	°C °C

**THERMAL RESISTANCES**

Symbol	Parameter	Value	Unit
R <sub>th (j-a)</sub>	Junction-ambient	400	°C/W
R <sub>th (j-l)</sub>	Junction-leads	150	°C/W

**ELECTRICAL CHARACTERISTICS** ( $T_j = 25\text{ }^\circ\text{C}$ )

Symbol	Parameter	Test Conditions	Types	Min.	Typ.	Max.	Unit
$V_{BO}$	Breakover Voltage*	C = 22 nF** See diagram 1	DC34	30	34	38	V
			DC38	35	38	42	
			DC42	39	42	45	
$[ +V_{BO}  -  -V_{BO} ]$	Breakover Voltage Symmetry	C = 22 nF** See diagram 1				$\pm 3$	V
$ \Delta V_{\pm} $	Dynamic Breakback Voltage*	$\Delta I = [I_{BO} \text{ to } I_F = 10\text{ mA}]$ See diagram 1		5			V
$V_O$	Output Voltage*	See diagram 2		5			V
$I_{BO}$	Breakover Current*	C = 22 nF**				50	$\mu\text{A}$
$t_r$	Rise Time*	See diagram 3			1.5		$\mu\text{s}$
$I_B$	Leakage Current*	$V_B = 0.5 V_{BO} \text{ max}$ See diagram 1				10	$\mu\text{A}$

\* Electrical characteristic applicable in both forward and reverse directions.  
 \*\* Connected in parallel with the device.

**DIAGRAM 1** : Current-voltage characteristics.

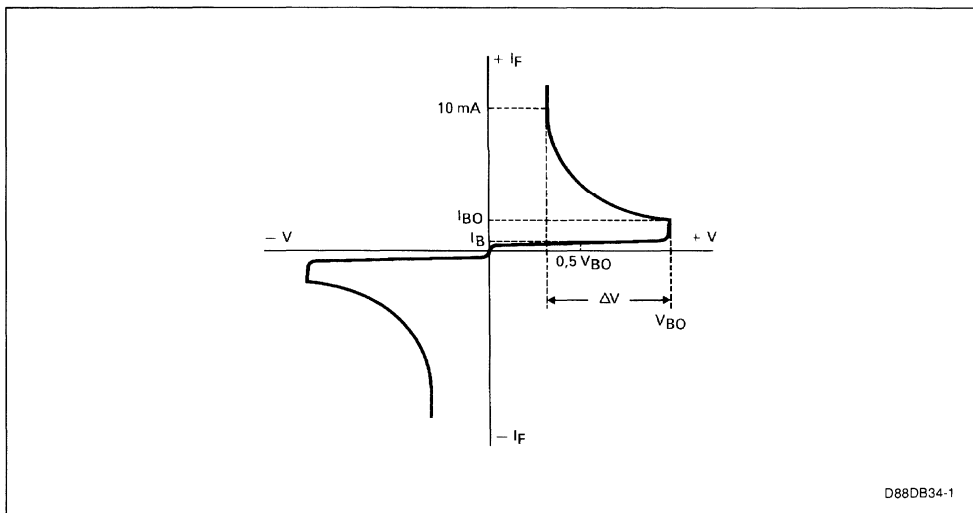

D88DB34-1

**DIAGRAM 2** : Test circuit for output voltage.

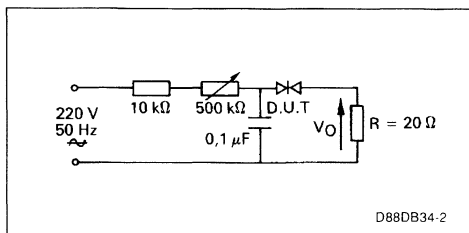

D88DB34-2

**DIAGRAM 3** : Test circuit see diagram 2. Adjust R for  $I_p = 0.5\text{ A}$ .

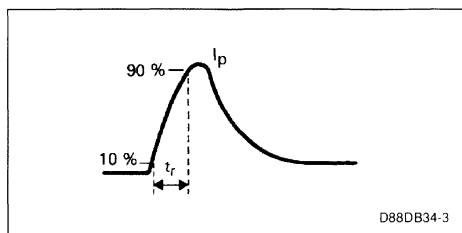

D88DB34-3

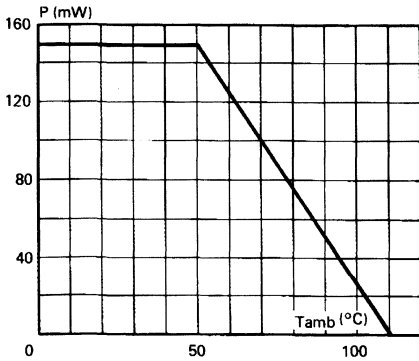

Fig. 1 - Power dissipation versus ambient temperature (maximum values).

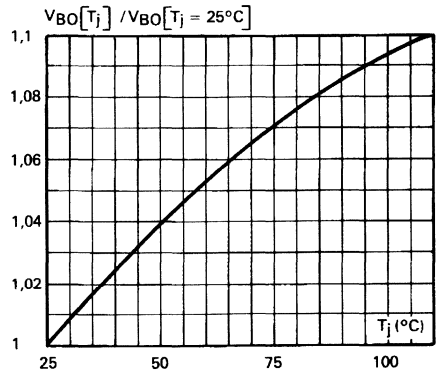

Fig. 2 - Relative variation of V<sub>BO</sub> versus junction temperature (typical values).

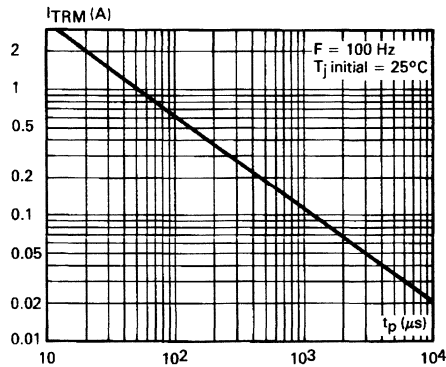
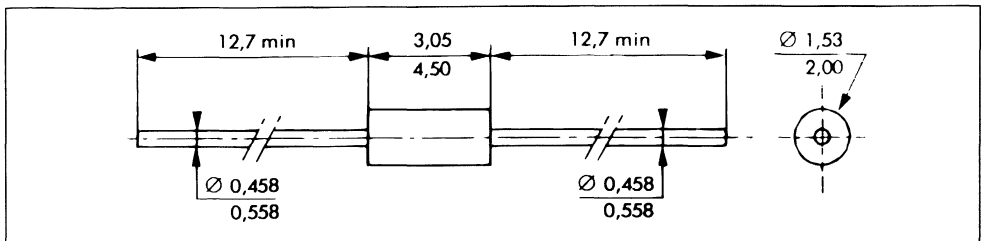

Fig. 3 - Peak pulse current versus pulse duration (maximum values).

**PACKAGE MECHANICAL DATA**

DO 35 Glass



Weight : 0.15 g.  
Marking : clear.



**TRIACS**

- GLASS PASSIVATED CHIP
- $I_{GT}$  SPECIFIED IN FOUR QUADRANTS

**ADVANTAGES**

- EXCELLENT  $(dv/dt)_C : > 10 V/\mu s$
- METALLIC ENCAPSULATION GIVES AN EXCELLENT THERMAL IMPEDANCE AND HIGH RELIABILITY CONSTRUCTION

**APPLICATIONS**

- MOTOR CONTROL
- HEATING CONTROL
- LIGHT DIMMER

**DESCRIPTION**

Power triacs suited for use on 220 V and 380 V main.

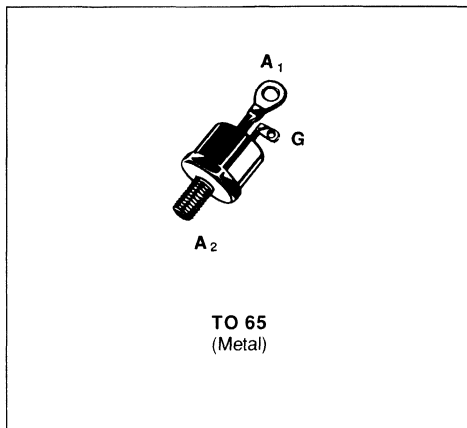
**ABSOLUTE RATINGS** (limiting values)

Symbol	Parameter		Value	Unit
$I_{T(RMS)}$	RMS on-state Current (360° conduction angle)	$T_C = 75\text{ °C}$	60	A
$I_{TSM}$	Non Repetitive Surge Peak on-state Current ( $T_j$ initial = 25 °C - Half sine wave)	$t = 8.3\text{ ms}$	550	A
		$t = 10\text{ ms}$	500	
$I^2t$	$I^2t$ Value for Fusing	$t = 10\text{ ms}$	1250	$A^2s$
$di/dt$	Critical Rate of Rise of on-state Current (1)	Repetitive $F = 50\text{ Hz}$	50	$A/\mu s$
		Non Repetitive	300	
$T_{stg}$ $T_j$	Storage and Operating Junction Temperature Range		- 40 to 150 - 40 to 125	$^{\circ}C$ $^{\circ}C$

Symbol	Parameter	TGAL					Unit
		602	604	606	608	610	
$V_{DRM}$	Repetitive Peak off-state Voltage (2)	200	400	600	800	1000	V

(1)  $I_C = 1.5\text{ A}$   $di_C/dt = 1\text{ A}/\mu s$

(2)  $T_j = 125\text{ °C}$ .

**THERMAL RESISTANCES**

Symbol	Parameter	Value	Unit
$R_{th(c-h)}$	Contact (case-heatsink) for Recommended Stud Torque	0.3	$^{\circ}C/W$
$R_{th(j-c)} DC$	Junction to Case for DC	0.66	$^{\circ}C/W$
$R_{th(j-c)} AC$	Junction to Case for 360 ° Conduction Angle ( $F = 50\text{ Hz}$ )	0.5	$^{\circ}C/W$

**GATE CHARACTERISTICS** (maximum values)

$P_{GM} = 40 \text{ W}$  ( $t_p = 10 \mu\text{s}$ )

$I_{GM} = 6 \text{ A}$  ( $t_p = 10 \mu\text{s}$ )

$P_G(AV) = 1 \text{ V}$

$V_{GM} = 16 \text{ V}$  ( $t_p = 10 \mu\text{s}$ )

**ELECTRICAL CHARACTERISTICS**

Symbol	Test Conditions			Quadrants	Min.	Typ.	Max.	Unit
$I_{GT}$	$T_j = 25 \text{ }^\circ\text{C}$ Pulse Duration > 20 $\mu\text{s}$	$V_D = 12 \text{ V}$	$R_L = 33 \text{ } \Omega$	I-III			100	mA
				II-IV			150	
$V_{GT}$	$T_j = 25 \text{ }^\circ\text{C}$ Pulse Duration > 20 $\mu\text{s}$	$V_D = 12 \text{ V}$	$R_L = 33 \text{ } \Omega$	I-II-III-IV			1.5	V
$V_{GD}$	$T_j = 125 \text{ }^\circ\text{C}$	$V_D = V_{DRM}$	$R_L = 3.3 \text{ k}\Omega$	I-II-III-IV	0.2			V
$I_{H^*}$	$T_j = 25 \text{ }^\circ\text{C}$	$I_T = 500 \text{ mA}$	Gate Open				100	mA
$I_L$	$T_j = 25 \text{ }^\circ\text{C}$ Pulse Duration > 20 $\mu\text{s}$	$V_D = 12 \text{ V}$	$I_G = 300 \text{ mA}$	I-III-IV		60		mA
				II		120		
$V_{TM}^*$	$T_j = 25 \text{ }^\circ\text{C}$	$I_{TM} = 100 \text{ A}$	$t_p = 10 \text{ ms}$				2	V
$I_{DRM}^*$	$T_j = 125 \text{ }^\circ\text{C}$	$V_{DRM}$ Specified					10	mA
$dv/dt^*$	$T_j = 125 \text{ }^\circ\text{C}$	Gate Open	Linear Slope up to $V_D = 67\% V_{DRM}$		250			V/ $\mu\text{s}$
$(dv/dt)_C^*$	$T_C = 75 \text{ }^\circ\text{C}$	$V_D = V_{DRM}$	$I_T = 100 \text{ A}$ $(di/dt)_C = 26.7 \text{ A/ms}$		10			V/ $\mu\text{s}$
$t_{gt}$	$T_j = 25 \text{ }^\circ\text{C}$	$V_D = V_{DRM}$	$I_T = 100 \text{ A}$ $I_G = 500 \text{ mA}$ $di_G/dt = 3.5 \text{ A}/\mu\text{s}$	I-II-III-IV		3		$\mu\text{s}$

\* For either polarity of electrode  $A_2$  voltage with reference to electrode  $A_1$ .

**PACKAGE MECHANICAL DATA**

TO 65 Metal

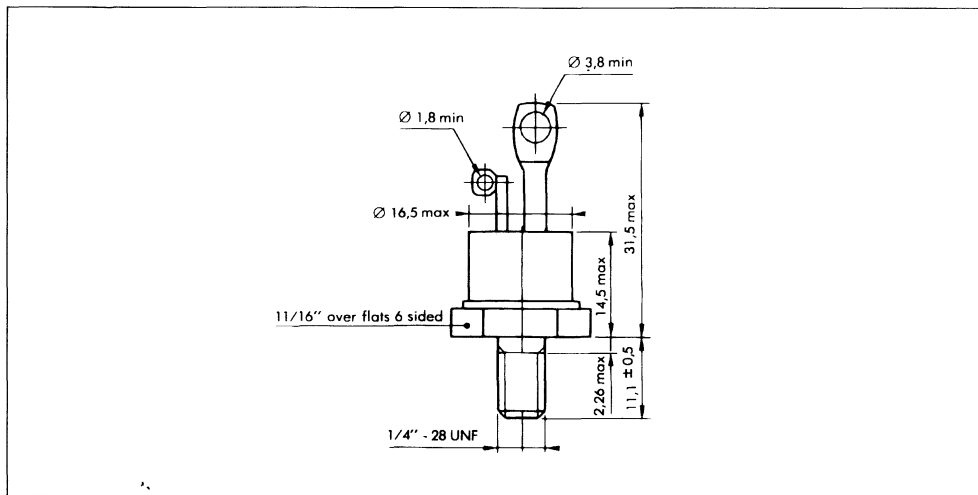

Cooling method : by conduction (method C)

Marking : type number

Weight : 19 g without accessories

Polarity : Electrode  $A_2$  to case

Stud torque : 3.5 mAN min - 3.8 mAN max.

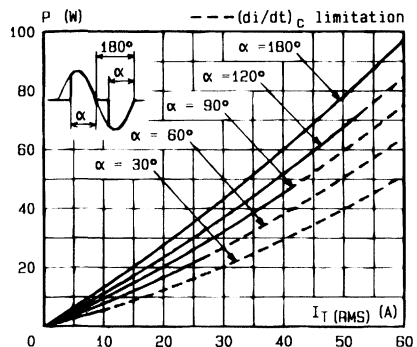

Fig. 1 - Maximum mean power dissipation versus RMS on-state current ( $F = 60$  Hz).

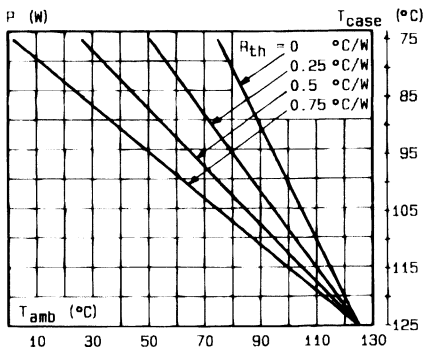

Fig. 2 - Correlation between maximum mean power dissipation and maximum allowable temperature ( $T_{amb}$  and  $T_{case}$ ) for different thermal resistances heatsink + contact.

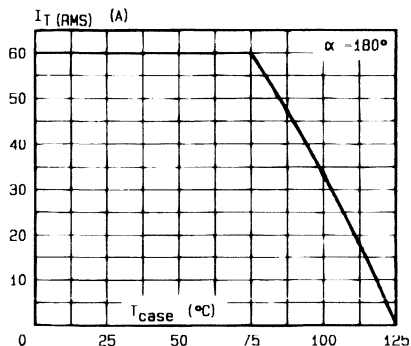

Fig. 3 - RMS on-state current versus case temperature.

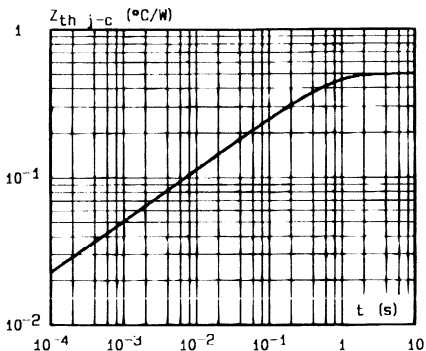

Fig. 4 - Thermal transient impedance junction to case versus pulse duration.

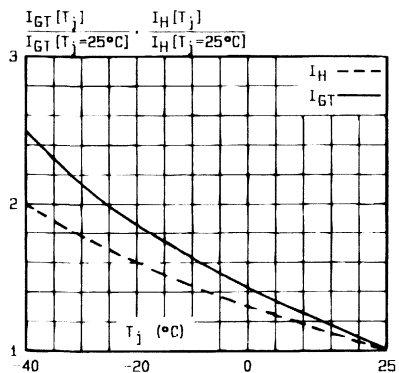

Fig. 5 - Relative variation of gate trigger current and holding current versus junction temperature.

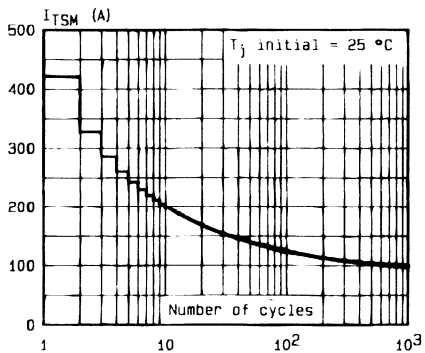

Fig. 6 - Non repetitive surge peak on-state current versus number of cycles.

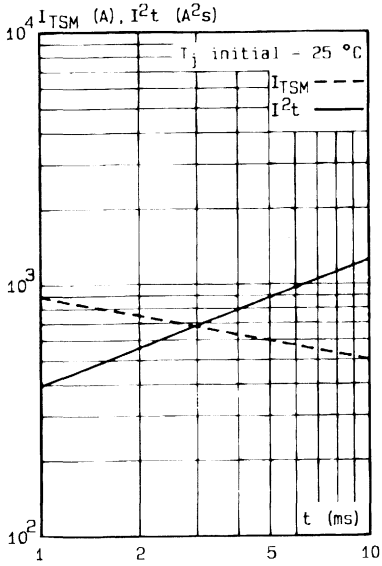

Fig.7 - Non repetitive surge peak on-state current for a sinusoidal pulse with width:  $t \leq 10\text{ms}$ , and corresponding value of  $I^2t$ .

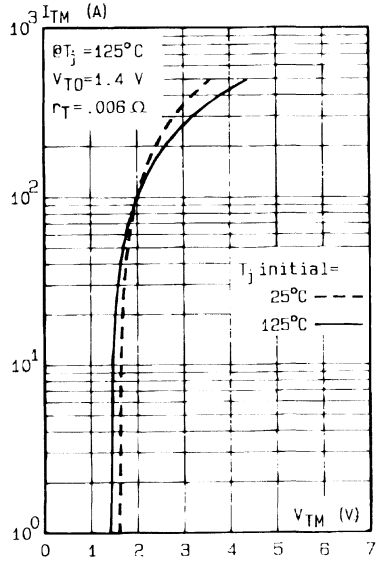

Fig.8 - On-state characteristic (maximum values).



**ALTERNISTORS**

- $(di/dt)_c > 213 \text{ A/ms (400 Hz)}$

**APPLICATIONS**

- POWER CONTROL ON INDUCTIVE LOAD (motor, transformer...)
- HIGH FREQUENCY OR HIGH  $(di/dt)_c$  LEVEL CIRCUITS.

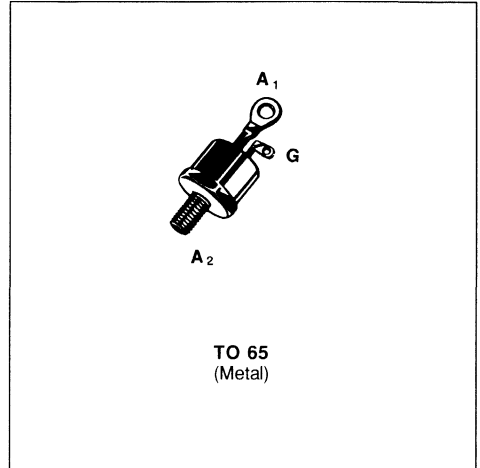
**DESCRIPTION**

New range of solid state AC - switches with very high commutating capability.

**ABSOLUTE RATINGS (limiting values)**

Symbol	Parameter		Value	Unit
$I_{T(RMS)}$	RMS on-state Current (360° conduction angle)	$T_C = 75 \text{ }^\circ\text{C}$	60	A
$I_{TSM}$	Non Repetitive Surge Peak on-state Current	$t = 10 \text{ ms}$	500	A
		$t = 8.3 \text{ ms}$	550	
		$t = 2.5 \text{ ms}$	840	
$I^2t$	$I^2t$ Value for Fusing	$t = 10 \text{ ms}$	1250	$\text{A}^2\text{s}$
$di/dt$	Critical Rate of Rise of on-state Current (1)		100	$\text{A}/\mu\text{s}$
$T_{stg}$ $T_j$	Storage and Operating Junction Temperature Range		- 40 to 150	$^\circ\text{C}$
			- 40 to 125	$^\circ\text{C}$

Symbol	Parameter	TGDV							Unit
		601	602	604	606	608	610	612	
$V_{DRM}$	Repetitive Peak off-state Voltage (2)	100	200	400	600	800	1000	1200	V

(1)  $I_G = 1.5 \text{ A}$   $di/dt = 1 \text{ A}/\mu\text{s}$

(2)  $T_j = 125 \text{ }^\circ\text{C}$ .

**THERMAL RESISTANCES**

Symbol	Parameter	Value	Unit
$R_{th(c-h)}$	Contact (case-heatsink) for Recommended Stud Torque	0.3	$^\circ\text{C}/\text{W}$
$R_{th(j-c)} \text{ DC}$	Junction to Case for DC	0.65	$^\circ\text{C}/\text{W}$
$R_{th(j-c)} \text{ AC}$	Junction to Case for 360° Conduction Angle ( $F = 50 \text{ Hz}$ )	0.48	$^\circ\text{C}/\text{W}$

**GATE CHARACTERISTICS** (maximum values)

$P_{GM} = 40 \text{ W}$  ( $t_p = 10 \mu\text{s}$ )

$I_{GM} = 8 \text{ A}$  ( $t_p = 10 \mu\text{s}$ )

$P_{G(AV)} = 1 \text{ W}$

$V_{GM} = 16 \text{ V}$  ( $t_p = 10 \mu\text{s}$ )

**ELECTRICAL CHARACTERISTICS**

Symbol	Test Conditions	Quadrants	Min.	Typ.	Max.	Unit
$I_{GT}$	$T_J = 25 \text{ }^\circ\text{C}$ $V_D = 12 \text{ V}$ $R_L = 33 \text{ } \Omega$ Pulse Duration > 20 $\mu\text{s}$	I-II-III			200	mA
$V_{GT}$	$T_J = 25 \text{ }^\circ\text{C}$ $V_D = 12 \text{ V}$ $R_L = 33 \text{ } \Omega$ Pulse Duration > 20 $\mu\text{s}$	I-II-III			1.5	V
$V_{GD}$	$T_J = 125 \text{ }^\circ\text{C}$ $V_D = V_{DRM}$ $R_L = 3.3 \text{ k}\Omega$	I-II-III	0.2			V
$I_{H^*}$	$T_J = 25 \text{ }^\circ\text{C}$ $I_T = 500 \text{ mA}$ Gate Open			50		mA
$I_L$	$T_J = 25 \text{ }^\circ\text{C}$ $V_D = 12 \text{ V}$ $I_G = 400 \text{ mA}$ Pulse Duration > 20 $\mu\text{s}$	I-III		50		mA
		II		100		
$V_{TM^*}$	$T_J = 25 \text{ }^\circ\text{C}$ $I_{TM} = 85 \text{ A}$ $t_p = 10 \text{ ms}$				2	V
$I_{DRM^*}$	$T_J = 100 \text{ }^\circ\text{C}$ $V_{DRM}$ Specified				5	mA
$dv/dt^*$	$T_J = 125 \text{ }^\circ\text{C}$ Gate Open Linear Slope upto $V_D = 67\% V_{DRM}$	$V_{DRM} \leq 800 \text{ V}$		500		V/ $\mu\text{s}$
		$V_{DRM} \geq 1000 \text{ V}$		250		
$(di/dt)_c^*$	$T_C = 75 \text{ }^\circ\text{C}$ $V_D = V_{DRM}$ $I_T = 85 \text{ A}$	$(dv/dt)_c = 200 \text{ V}/\mu\text{s}$		50		A/ms
		$(dv/dt)_c = 10 \text{ V}/\mu\text{s}$		213		
$t_{gt}$	$T_J = 25 \text{ }^\circ\text{C}$ $V_D = V_{DRM}$ $I_T = 85 \text{ A}$ $I_G = 0.5 \text{ A}$ $di_G/dt = 3.5 \text{ A}/\mu\text{s}$	I-II-III		2.5		$\mu\text{s}$

\* For either polarity of electrode  $A_2$  voltage with reference to electrode  $A_1$ .

**PACKAGE MECHANICAL DATA : TO 65 Metal**

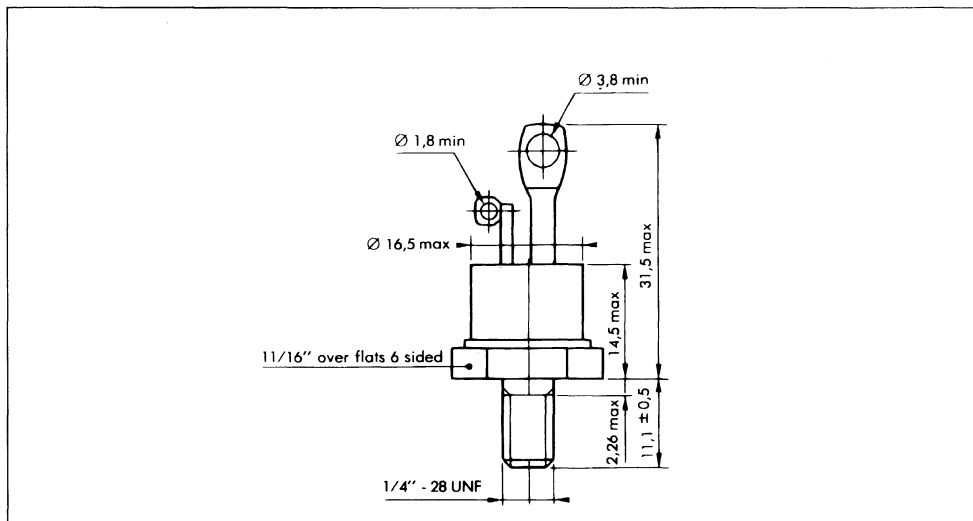

Cooling method : by conduction (method C)  
 Marking : type number  
 Weight : 19 g  
 Polarity : Electrode  $A_2$  to case  
 Stud torque : 3.5 mAN min - 3.8 mAN max

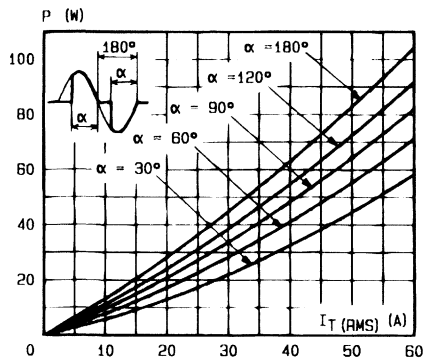

Fig. 1 - Maximum mean power dissipation versus RMS on-state current.

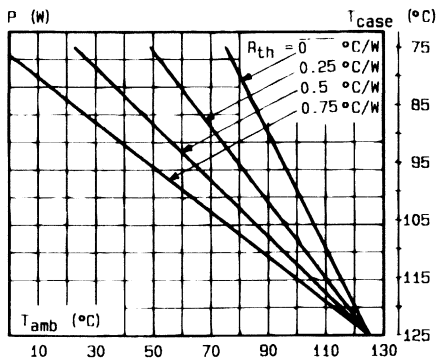

Fig. 2 - Correlation between maximum mean power dissipation and maximum allowable temperatures ( $T_{amb}$  and  $T_{case}$ ) for different thermal resistances heatsink + contact.

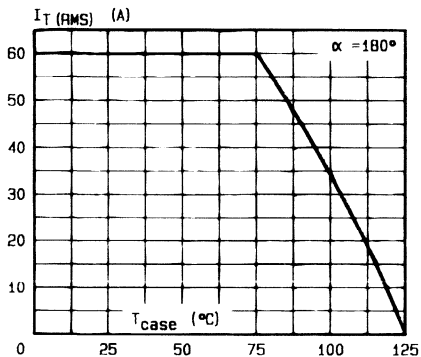

Fig. 3 - RMS on-state current versus case temperature.

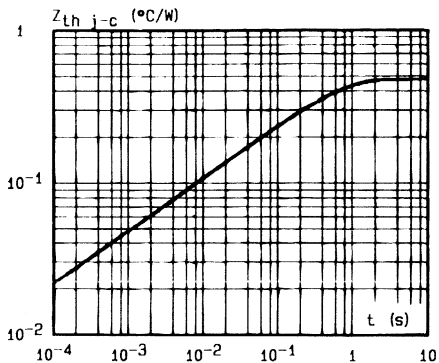

Fig. 4 - Thermal transient impedance junction to case versus pulse duration.

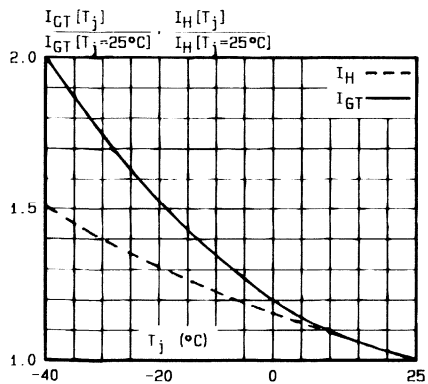

Fig. 5 - Relative variation of gate trigger current and holding current versus junction temperature.

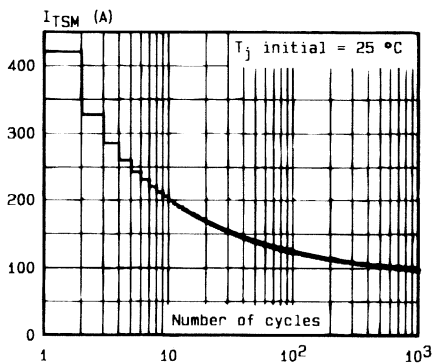

Fig. 6 - Non repetitive surge peak on-state current versus number of cycles.

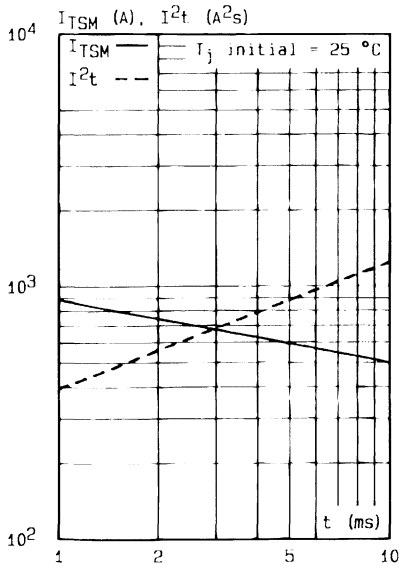

Fig.7 - Non repetitive surge peak on-state current for a sinusoidal pulse with width :  $t \leq 10$  ms, and corresponding value of  $I^2t$ .

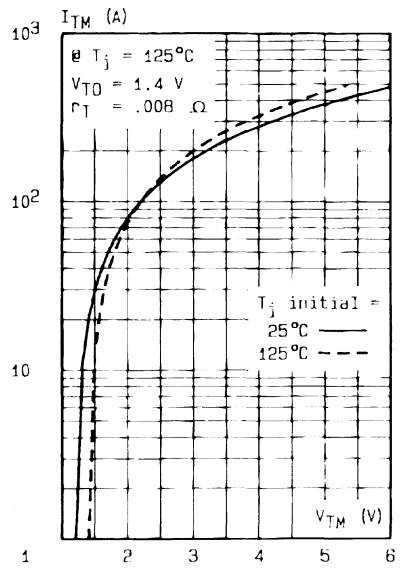

Fig.8 - On-state characteristics (maximum values).

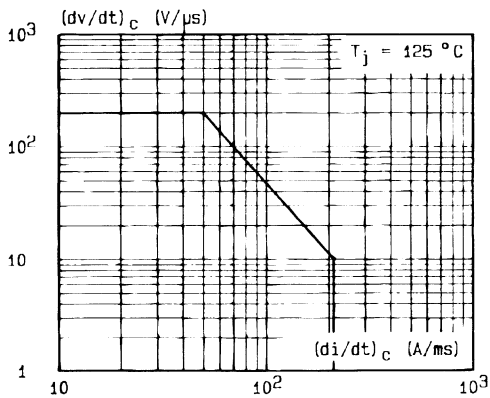

Fig.9 - Safe operating area.

## SENSITIVE GATE TRIACS

- GLASS PASSIVATED CHIP
- HIGH SURGE CURRENT

### DESCRIPTION

Low power triacs suited for 50 and 60 Hz up to 380 V<sub>RMS</sub>.

### APPLICATIONS

- CONTROL SPEED FOR LITTLE MOTORS ;  
ELECTRIC PUMP OR VENTILATOR, SEWING MACHINE
- RELAY, DETECTOR, ALARM SYSTEM
- ELECTRONIC STARTER FOR LAMP
- HIGH POWER TRIAC DRIVER

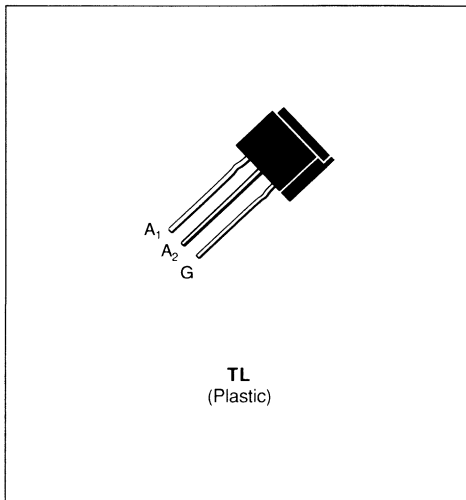

### ABSOLUTE RATINGS (limiting values)

Symbol	Parameter	Value	Unit
$I_{T(RMS)}$	RMS on-state Current (360° conduction angle)	$T_j = 40\text{ °C}$ 1	A
$I_{T(RMS)}$	RMS on-state Current on Printed Circuit (360° conduction angle)	$T_a = 25\text{ °C}$ 0.77	A
$I_{TSM}$	Non Repetitive Surge Peak on-state Current ( $T_j$ initial = 25 °C - Half sine wave)	$t = 8.3\text{ ms}$ 16 $t = 10\text{ ms}$ 15	A
$I^2t$	$I^2t$ Value for Fusing	$t = 10\text{ ms}$ 1.125	A <sup>2</sup> s
di/dt	Critical Rate of Rise of on-state Current (1)	Repetitive 10	A/μs
$T_{stg}$ $T_j$	Storage and Operating Junction Temperature Range	- 40 to 150 - 40 to 110	°C °C

Symbol	Parameter	TLC111A	TLC221A	TLC331A	TLC381A	Unit
$V_{DRM}$	Repetitive Peak off-state Voltage (2)	200	400	600	700	V

- (1)  $I_G = 250\text{ mA}$      $di/dt = 1\text{ A/μs}$   
 (2)  $T_j = 110\text{ °C}$ .

### THERMAL RESISTANCES

Symbol	Parameter	Value	Unit
$R_{th(j-a)}$	Junction to Ambient on Printed Circuit	75	°C/W
$R_{th(j-l)}$	Junction-leads for 360° Conduction Angle (F = 50 Hz)	45	°C/W

**GATE CHARACTERISTICS** (maximum values)

$P_{GM} = 2 \text{ W}$  ( $t_p = 10 \mu\text{s}$ )       $I_{GM} = 1 \text{ A}$  ( $t_p = 10 \mu\text{s}$ )  
 $P_{G(AV)} = 0.1 \text{ W}$        $V_{GM} = 16 \text{ V}$  ( $t_p = 10 \mu\text{s}$ )

**ELECTRICAL CHARACTERISTICS**

Symbol	Test Conditions			Quadrants	Min.	Typ.	Max.	Unit
$I_{GT}$	$T_J = 25 \text{ }^\circ\text{C}$ Pulse Duration > 20 $\mu\text{s}$	$V_D = 12 \text{ V}$	$R_L = 33 \text{ }\Omega$	I-II-III			10	mA
				IV			25	
$V_{GT}$	$T_J = 25 \text{ }^\circ\text{C}$ Pulse Duration > 20 $\mu\text{s}$	$V_D = 12 \text{ V}$	$R_L = 33 \text{ }\Omega$	I-II-III-IV			1.5	V
$V_{GD}$	$T_J = 110 \text{ }^\circ\text{C}$	$V_D = V_{DRM}$	$R_L = 3.3 \text{ k}\Omega$	I-II-III-IV	0.2			V
$I_{H^*}$	$T_J = 25 \text{ }^\circ\text{C}$	$I_T = 100 \text{ mA}$	Gate Open				25	mA
$I_L$	$T_J = 25 \text{ }^\circ\text{C}$ Pulse Duration > 20 $\mu\text{s}$	$V_D = 12 \text{ V}$	$I_G = 50 \text{ mA}$	I-II-III-IV			25	mA
$V_{TM}^*$	$T_J = 25 \text{ }^\circ\text{C}$	$I_{TM} = 1.4 \text{ A}$	$t_p = 10 \text{ ms}$				1.8	V
$I_{DRM}^*$	$V_{DRM}$ Specified						0.01	mA
							0.75	
$dv/dt^*$	$T_J = 110 \text{ }^\circ\text{C}$	Gate Open				20		V/ $\mu\text{s}$
	Linear Slope up to $V_D = 67\% V_{DRM}$							
$(dv/dt)_c^*$	$T_J = 40 \text{ }^\circ\text{C}$ $(di/dt)_c = 0.4 \text{ A/ms}$	$V_D = V_{DRM}$	$I_T = 1.4 \text{ A}$			5		V/ $\mu\text{s}$
$t_{gt}$	$T_J = 25 \text{ }^\circ\text{C}$ $I_G = 100 \text{ mA}$	$V_D = V_{DRM}$ $di_G/dt = 1 \text{ A}/\mu\text{s}$	$I_T = 1.4 \text{ A}$	I-II-III-IV		3		$\mu\text{s}$

\* For either polarity of electrode A<sub>2</sub> voltage with reference to electrode A<sub>1</sub>.

**PACKAGE MECHANICAL DATA**

TL Plastic

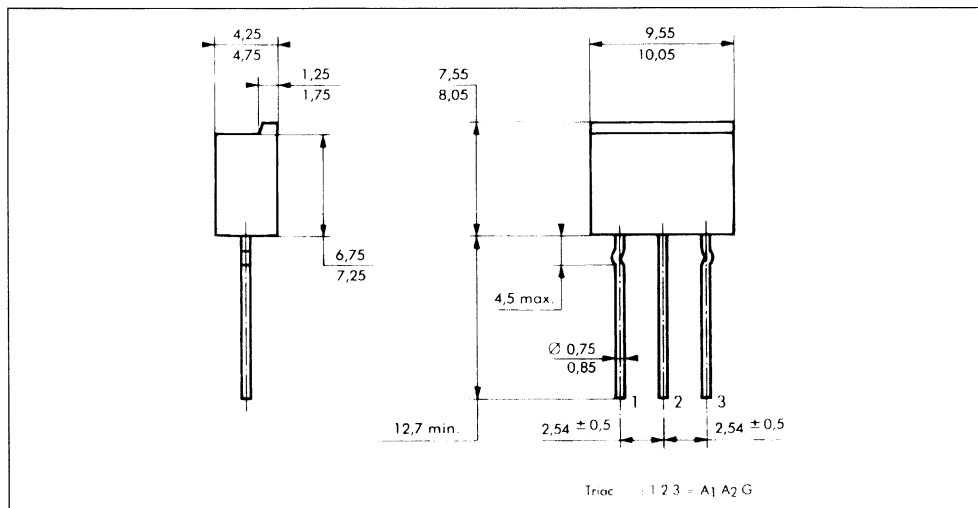

Cooling method : by convection (method A)  
 Marking : type number  
 Weight : 0.8 g.

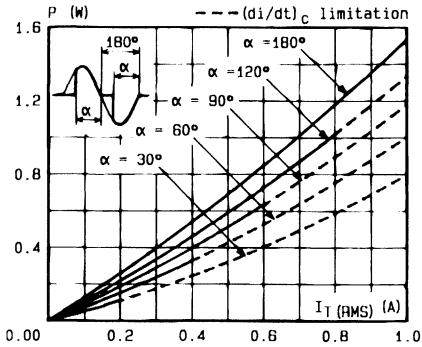

Fig. 1 - Maximum mean power dissipation versus RMS on-state current (F = 60 Hz).

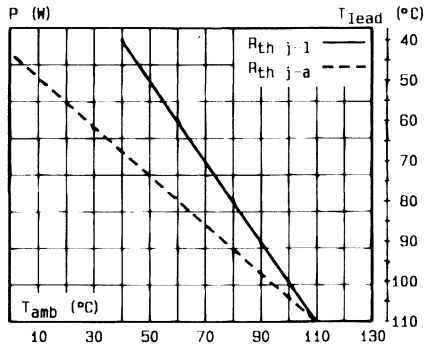

Fig. 2 - Correlation between maximum mean power dissipation and maximum allowable temperatures (T<sub>amb</sub> and T<sub>lead</sub>). resistances heatsink + contact.

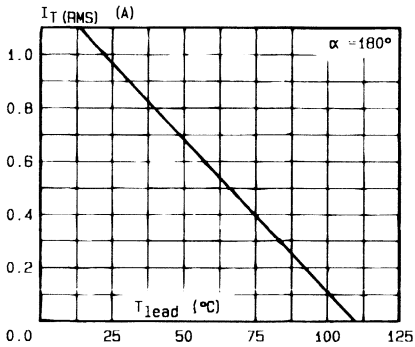

Fig. 3 - RMS on-state current versus lead temperature.

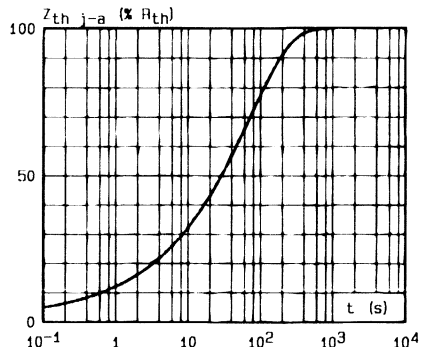

Fig. 4 - Thermal transient impedance junction to ambient versus pulse duration.

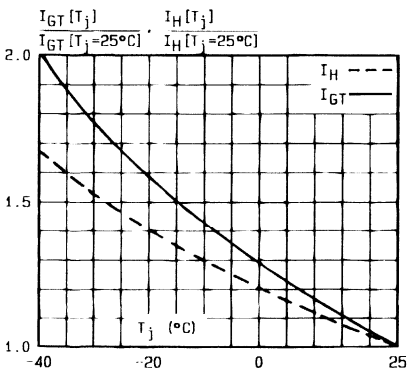

Fig. 5 - Relative variation of gate trigger current and holding current versus junction temperature.

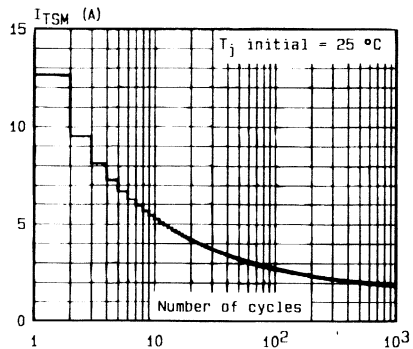

Fig. 6 - Non repetitive surge peak on state current versus number of cycles.

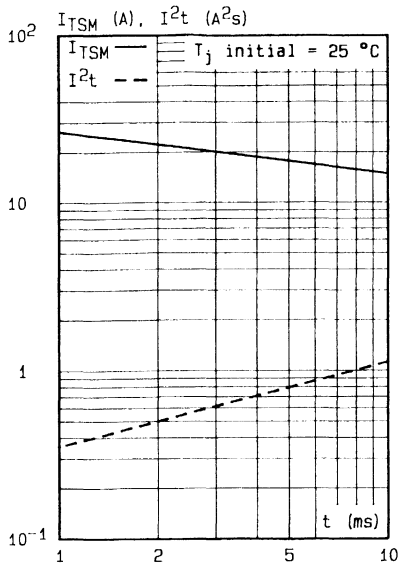

Fig.7 - Non repetitive surge peak on-state current for a sinusoidal pulse with width :  $t \leq 10$  ms, and corresponding value of  $I^2t$ .

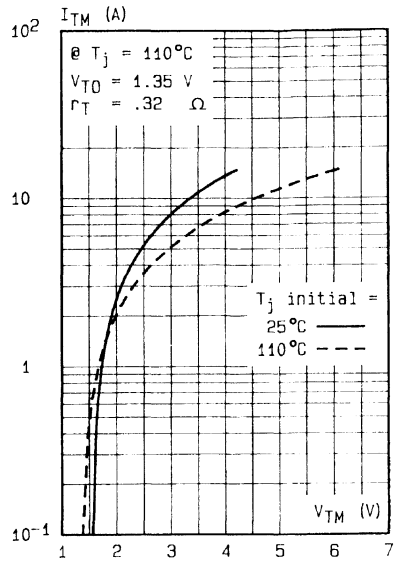

Fig.8 - On-state characteristics (maximum values).





**TRIACS**

- GLASS PASSIVATED CHIP
- HIGH SURGE CURRENT

**DESCRIPTION**

Low power triacs suited for 50 and 60 Hz up to 380 V<sub>RMS</sub>.

**APPLICATIONS**

- CONTROL SPEED FOR LITTLE MOTORS ;  
ELECTRIC PUMP OR VENTILATOR, SEWING MACHINE
- RELAY, DETECTOR, ALARM SYSTEM
- ELECTRONIC STARTER FOR LAMP
- HIGH POWER TRIAC DRIVER

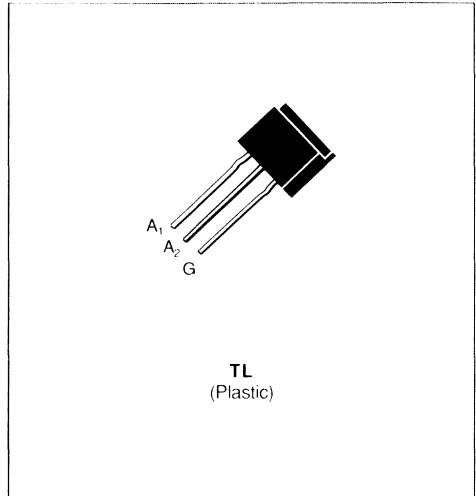

**ABSOLUTE RATINGS** (limiting values)

Symbol	Parameter		Value	Unit
$I_{T(RMS)}$	RMS on-state Current (360° conduction angle)	$T_J = 40\text{ °C}$	1	A
$I_{T(RMS)}$	RMS on-state Current on Printed Circuit (360° conduction angle)	$T_{ca} = 25\text{ °C}$	0.77	A
$I_{TSM}$	Non Repetitive Surge Peak on state Current ( $T_J$ initial = 25 °C - Half sine wave)	$t = 8.3\text{ ms}$	16	A
		$t = 10\text{ ms}$	15	
$I^2t$	$I^2t$ Value for Fusing	$t = 10\text{ ms}$	1.125	A <sup>2</sup> s
$di/dt$	Critical Rate of Rise of on-state Current (1)	Repetitive	10	A/ $\mu$ s
$T_{stg}$	Storage and Operating Junction Temperature Range		- 40 to 150	°C
$T_J$			- 40 to 110	°C

Symbol	Parameter	TLC111B	TLC221B	TLC331B	TLC381B	Unit
$V_{DRM}$	Repetitive Peak off-state Voltage (2)	200	400	600	700	V

(1)  $I_G = 500\text{ mA}$   $di/dt = 1\text{ A}/\mu\text{s}$   
 (2)  $T_J = 110\text{ °C}$

**THERMAL RESISTANCES**

Symbol	Parameter	Value	Unit
$R_{th(j-a)}$	Junction to Ambient on Printed Circuit	75	C/W
$R_{th(j-l)}$	Junction-leads for 360° Conduction Angle (F = 50 Hz)	45	C/W

**GATE CHARACTERISTICS** (maximum values)

$P_{GM} = 2 \text{ W}$  ( $t_p = 10 \mu\text{s}$ )

$I_{GM} = 1 \text{ A}$  ( $t_p = 10 \mu\text{s}$ )

$P_{G(AV)} = 0.1 \text{ W}$

$V_{GM} = 16 \text{ V}$  ( $t_p = 10 \mu\text{s}$ )

**ELECTRICAL CHARACTERISTICS**

Symbol	Test Conditions	Quadrants	Min.	Typ.	Max.	Unit
$I_{GT}$	$T_j = 25 \text{ }^\circ\text{C}$ $V_D = 12 \text{ V}$ Pulse Duration > 20 $\mu\text{s}$	I-II-III			25	mA
		IV			50	
$V_{GT}$	$T_j = 25 \text{ }^\circ\text{C}$ $V_D = 12 \text{ V}$ Pulse Duration > 20 $\mu\text{s}$	I-II-III-IV			1.5	V
$V_{GD}$	$T_j = 110 \text{ }^\circ\text{C}$ $V_D = V_{DRM}$	$R_L = 3.3 \text{ k}\Omega$	I-II-III-IV	0.2		V
$I_{H^*}$	$T_j = 25 \text{ }^\circ\text{C}$ $I_T = 100 \text{ mA}$	Gate Open		8		mA
$I_L$	$T_j = 25 \text{ }^\circ\text{C}$ $V_D = 12 \text{ V}$ Pulse Duration > 20 $\mu\text{s}$	$I_G = 100 \text{ mA}$	I-II-III-IV	8		mA
$V_{TM^*}$	$T_j = 25 \text{ }^\circ\text{C}$	$I_{TM} = 1.4 \text{ A}$			1.8	V
$I_{DRM^*}$	$V_{DRM}$ Specified	$T_j = 25 \text{ }^\circ\text{C}$			0.01	mA
		$T_j = 110 \text{ }^\circ\text{C}$			0.75	
$dv/dt^*$	$T_j = 110 \text{ }^\circ\text{C}$ Gate Open Linear Slope up to $V_D = 67\% V_{DRM}$		20			V/ $\mu\text{s}$
$(dv/dt)_c^*$	$T_j = 40 \text{ }^\circ\text{C}$ $V_D = V_{DRM}$ $(di/dt)_c = 0.4 \text{ A/ms}$	$I_T = 1.4 \text{ A}$	5			V/ $\mu\text{s}$
$t_{gt}$	$T_j = 25 \text{ }^\circ\text{C}$ $V_D = V_{DRM}$ $I_G = 100 \text{ mA}$	$di_G/dt = 1 \text{ A}/\mu\text{s}$		3		$\mu\text{s}$

\* For either polarity of electrode A: voltage with reference to electrode A1.

**PACKAGE MECHANICAL DATA**

TL Plastic

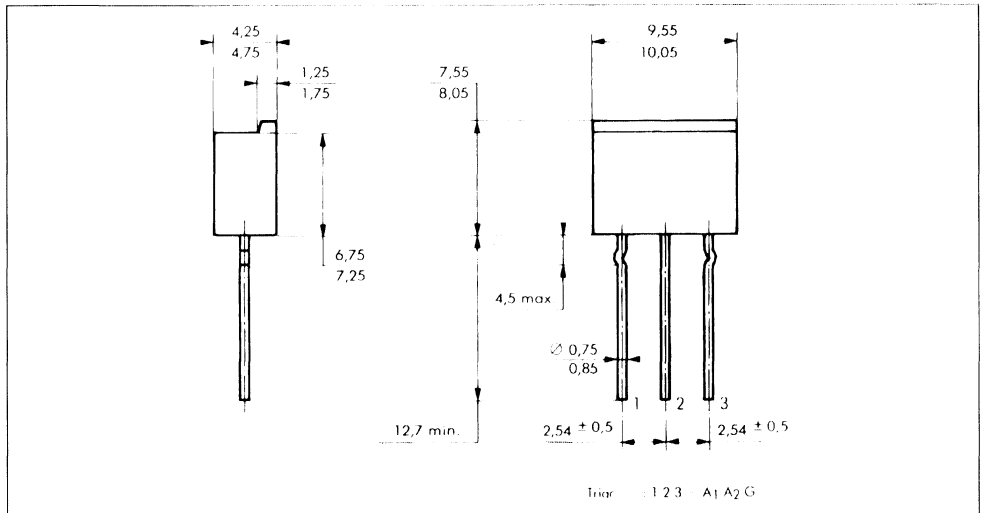

Cooling method : by convection (method A)

Marking : type number

Weight : 0.8 g

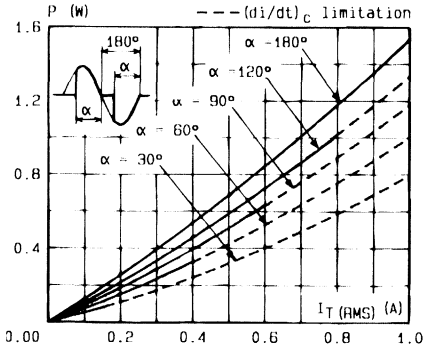

Fig. 1 - Maximum mean power dissipation versus RMS on state current.

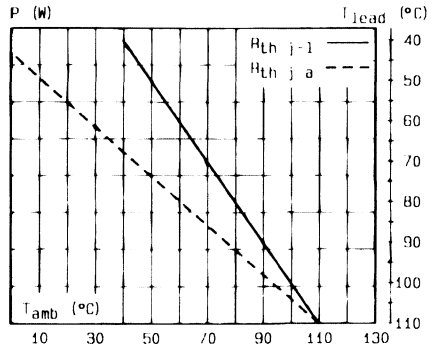

Fig. 2 - Correlation between maximum mean power dissipation and maximum allowable temperatures ( $T_{amb}$  and  $T_{lead}$ ).

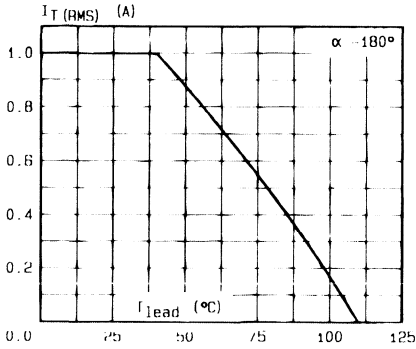

Fig. 3 - RMS on-state current versus lead temperature.

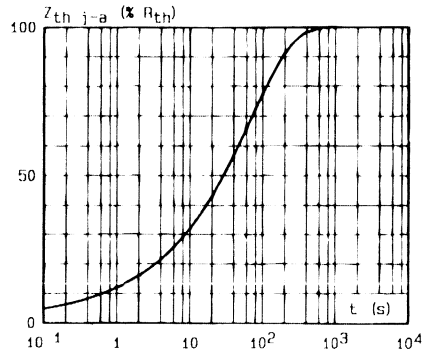

Fig. 4 - Thermal transient impedance junction to ambient versus pulse duration.

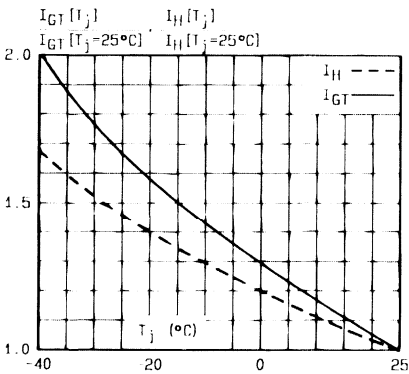

Fig. 5 - Relative variation of gate trigger current and holding current versus junction temperature.

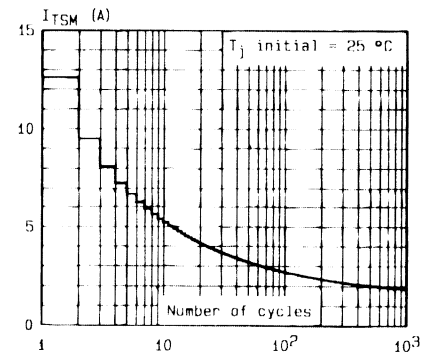

Fig. 6 - Non repetitive surge peak on-state current versus number of cycles.

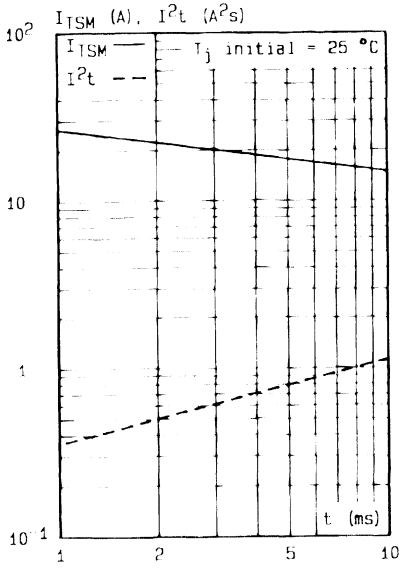

Fig.7 - Non repetitive surge peak on-state current for a sinusoidal pulse with width :  $t \leq 10$  ms, and corresponding value of  $I^2t$ .

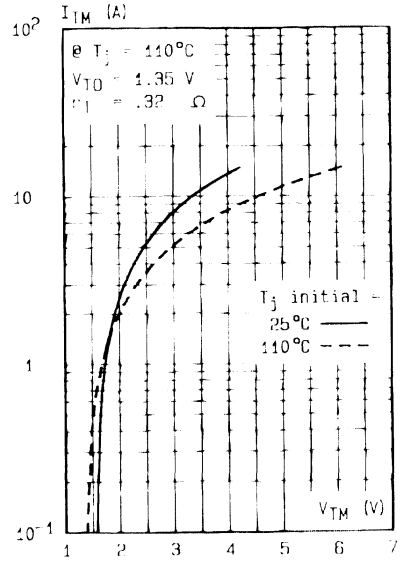
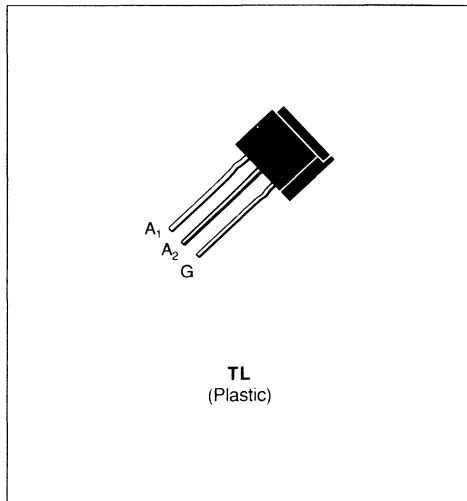

Fig.8 - On-state characteristics (maximum values).

## SENSITIVE GATE TRIACS

- GLASS PASSIVATED CHIP
- HIGH SURGE CURRENT



### DESCRIPTION

Low power triacs suited for 50 and 60 Hz up to 380 V<sub>RMS</sub>.

### APPLICATIONS

- CONTROL SPEED FOR LITTLE MOTORS ;  
ELECTRIC PUMP OR VENTILATOR, SEWING MACHINE
- RELAY, DETECTOR, ALARM SYSTEM
- ELECTRONIC STARTER FOR LAMP
- HIGH POWER TRIAC DRIVER

### ABSOLUTE RATINGS (limiting values)

Symbol	Parameter		Value	Unit
$I_{T(RMS)}$	RMS on-state Current (360° conduction angle)	$T_j = 40\text{ °C}$	1	A
$I_{T(RMS)}$	RMS on-state Current on Printed Circuit (360° conduction angle)	$T_a = 25\text{ °C}$	0.77	A
$I_{TSM}$	Non Repetitive Surge Peak on-state Current ( $T_j$ initial = 25 °C - Half sine wave)	$t = 8.3\text{ ms}$	16	A
		$t = 10\text{ ms}$	15	
$I^2t$	$I^2t$ Value for Fusing	$t = 10\text{ ms}$	1.125	A <sup>2</sup> s
$di/dt$	Critical Rate of Rise of on-state Current (1)	Repetitive	10	A/ $\mu$ s
$T_{stg}$ $T_j$	Storage and Operating Junction Temperature Range		- 40 to 150	°C
			- 40 to 110	°C

Symbol	Parameter	TLC111D	TLC221D	TLC331D	TLC381D	Unit
$V_{DRM}$	Repetitive Peak off-state Voltage (2)	200	400	600	700	V

(1)  $I_G = 100\text{ mA}$      $di/dt = 1\text{ A}/\mu\text{s}$

(2)  $T_j = 110\text{ °C}$ .

### THERMAL RESISTANCES

Symbol	Parameter	Value	Unit
$R_{th(j-a)}$	Junction to Ambient on Printed Circuit	75	°C/W
$R_{th(j-l)}$	Junction-leads for 360° Conduction Angle (F = 50 Hz)	45	°C/W

**GATE CHARACTERISTICS** (maximum values)

$P_{GM} = 2 \text{ W}$  ( $t_p = 10 \mu\text{s}$ )       $I_{GM} = 1 \text{ A}$  ( $t_p = 10 \mu\text{s}$ )  
 $P_{G(AV)} = 0.1 \text{ W}$        $V_{GM} = 16 \text{ V}$  ( $t_p = 10 \mu\text{s}$ )

**ELECTRICAL CHARACTERISTICS**

Symbol	Test Conditions			Quadrants	Min.	Typ.	Max.	Unit
$I_{GT}$	$T_j = 25 \text{ }^\circ\text{C}$ Pulse Duration > 20 $\mu\text{s}$	$V_D = 12 \text{ V}$	$R_L = 33 \text{ } \Omega$	I-II-III			5	mA
				IV			10	
$V_{GT}$	$T_j = 25 \text{ }^\circ\text{C}$ Pulse Duration > 20 $\mu\text{s}$	$V_D = 12 \text{ V}$	$R_L = 33 \text{ } \Omega$	I-II-III-IV			1.5	V
$V_{GD}$	$T_j = 110 \text{ }^\circ\text{C}$	$V_D = V_{DRM}$	$R_L = 3.3 \text{ k}\Omega$	I-II-III-IV	0.2			V
$I_H^*$	$T_j = 25 \text{ }^\circ\text{C}$	$I_T = 100 \text{ mA}$	Gate Open				15	mA
$I_L$	$T_j = 25 \text{ }^\circ\text{C}$ Pulse Duration > 20 $\mu\text{s}$	$V_D = 12 \text{ V}$	$I_G = 20 \text{ mA}$	I-II-III-IV			15	mA
$V_{TM}^*$	$T_j = 25 \text{ }^\circ\text{C}$	$I_{TM} = 1.4 \text{ A}$	$t_p = 10 \text{ ms}$				1.8	V
$I_{DRM}^*$	$V_{DRM}$ Specified	$T_j = 25 \text{ }^\circ\text{C}$					0.01	mA
		$T_j = 110 \text{ }^\circ\text{C}$					0.75	
$dv/dt^*$	$T_j = 110 \text{ }^\circ\text{C}$ Linear Slope up to $V_D = 67\% V_{DRM}$	Gate Open				10		V/ $\mu\text{s}$
$(dv/dt)_c^*$	$T_j = 40 \text{ }^\circ\text{C}$ $(di/dt)_c = 0.4 \text{ A/ms}$	$V_D = V_{DRM}$	$I_T = 1.4 \text{ A}$			1		V/ $\mu\text{s}$
$t_{gt}$	$T_j = 25 \text{ }^\circ\text{C}$	$V_D = V_{DRM}$ $di_G/dt = 1 \text{ A}/\mu\text{s}$	$I_T = 1.4 \text{ A}$	I-II-III-IV		3		$\mu\text{s}$

\* For either polarity of electrode  $A_2$  voltage with reference to electrode  $A_1$ .

**PACKAGE MECHANICAL DATA**

TL Plastic

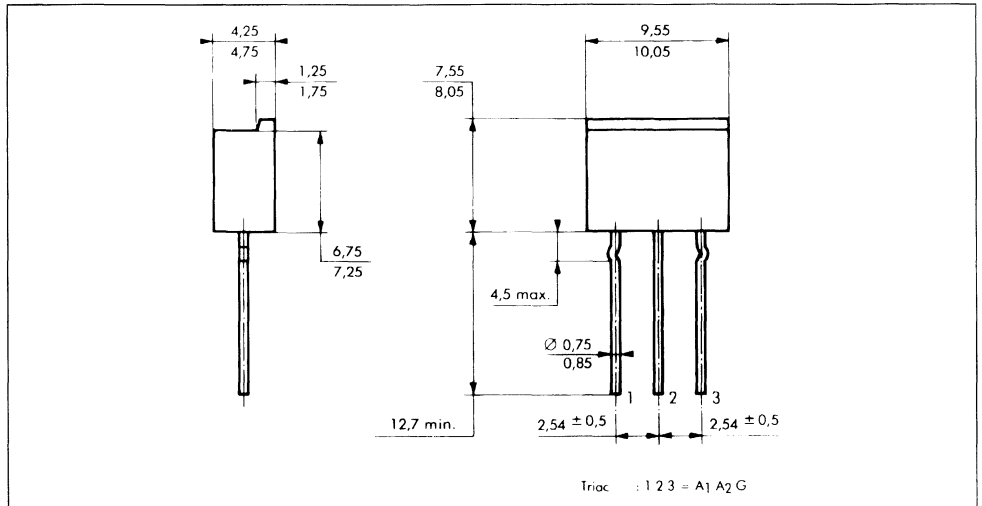

Cooling method : by convection (method A)  
 Marking : type number  
 Weight : 0.8 g

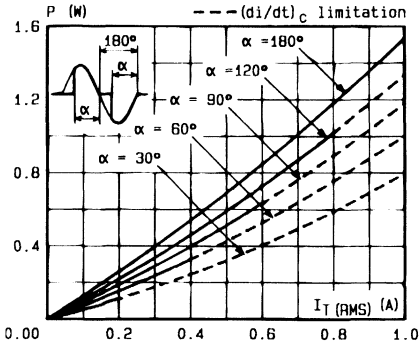

Fig. 1 - Maximum mean power dissipation versus RMS on-state current (F = 60 Hz).

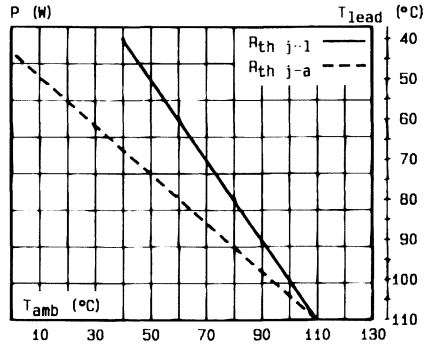

Fig. 2 - Correlation between maximum mean power dissipation and maximum allowable temperatures ( $T_{amb}$  and  $T_{lead}$ ). resistances heatsink + contact.

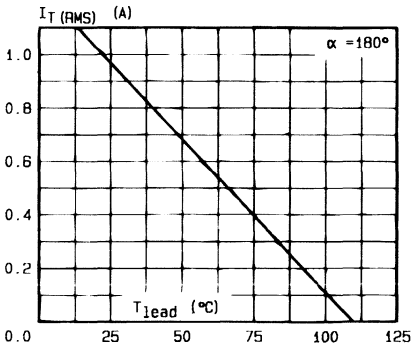

Fig. 3 - RMS on-state current versus lead temperature.

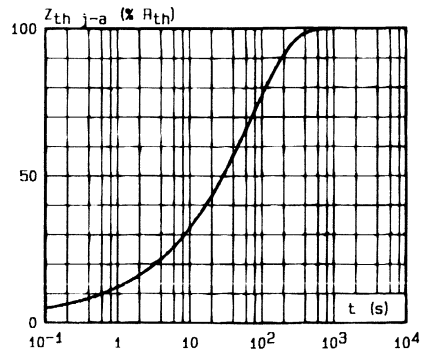

Fig. 4 - Thermal transient impedance junction to ambient versus pulse duration.

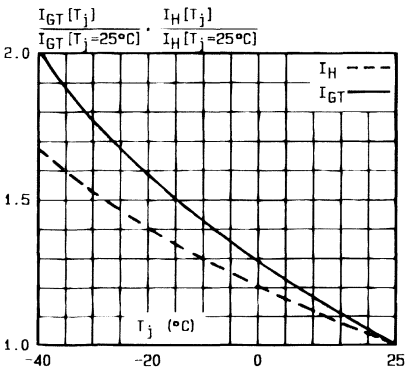

Fig. 5 - Relative variation of gate trigger current and holding current versus junction temperature.

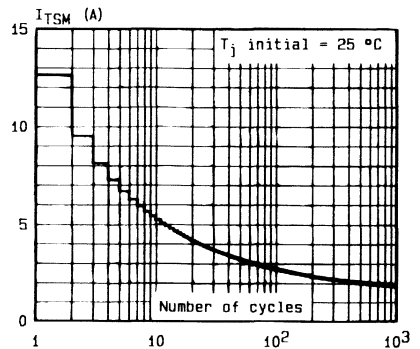

Fig. 6 - Non repetitive surge peak on state current versus number of cycles.

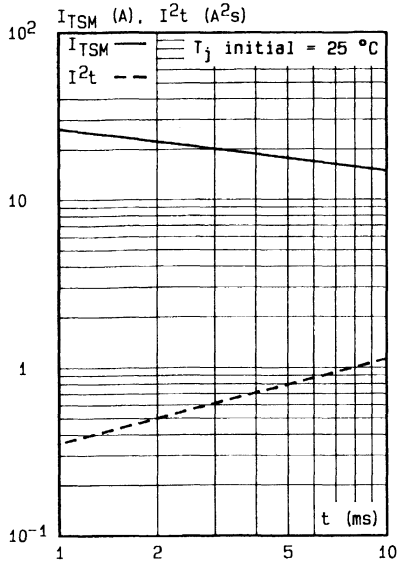

Fig.7 - Non repetitive surge peak on-state current for a sinusoidal pulse with width :  $t \leq 10$  ms, and corresponding value of  $I^2t$ .

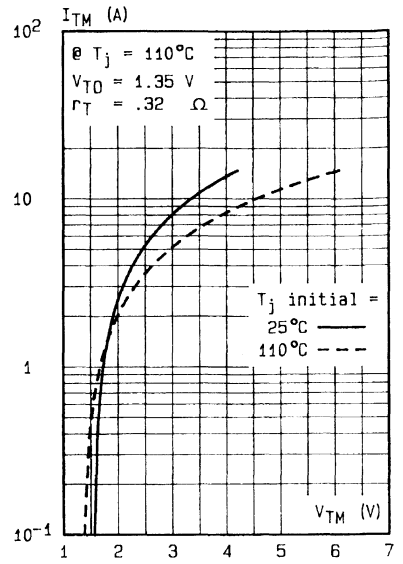

Fig.8 - On-state characteristics (maximum values).





**SENSITIVE GATE TRIACS**

- GLASS PASSIVATED CHIP
- HIGH SURGE CURRENT

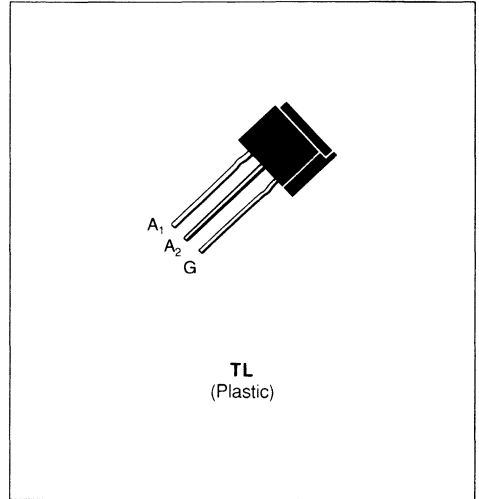

**DESCRIPTION**

Low power triacs suited for 50 and 60 Hz up to 380 V<sub>RMS</sub>.

**APPLICATIONS**

- CONTROL SPEED FOR LITTLE MOTORS ; ELECTRIC PUMP OR VENTILATOR, SEWING MACHINE
- RELAY, DETECTOR, ALARM SYSTEM
- ELECTRONIC STARTER FOR LAMP
- HIGH POWER TRIAC DRIVER

**ABSOLUTE RATINGS** (limiting values)

Symbol	Parameter		Value	Unit
$I_{T(RMS)}$	RMS on-state Current (360° conduction angle)	$T_J = 40\text{ °C}$	1	A
$I_{T(RMS)}$	RMS on-state Current on Printed Circuit (360° conduction angle)	$T_a = 25\text{ °C}$	0.77	A
$I_{TSM}$	Non Repetitive Surge Peak on-state Current ( $T_J$ initial = 25 °C - Half sine wave)	$t = 8.3\text{ ms}$	16	A
		$t = 10\text{ ms}$	15	
$I^2t$	$I^2t$ Value for Fusing	$t = 10\text{ ms}$	1.125	A <sup>2</sup> s
$di/dt$	Critical Rate of Rise of on-state Current (1)	Repetitive	10	A/ $\mu$ s
$T_{stg}$ $T_J$	Storage and Operating Junction Temperature Range		- 40 to 150 - 40 to 110	°C °C

Symbol	Parameter	TLC111S	TLC221S	TLC331S	TLC381S	Unit
$V_{DRM}$	Repetitive Peak off-state Voltage (2)	200	400	600	700	V

(1)  $I_G = 100\text{ mA}$   $di/dt = 1\text{ A}/\mu\text{s}$   
 (2)  $T_J = 110\text{ °C}$ .

**THERMAL RESISTANCES**

Symbol	Parameter	Value	Unit
$R_{th(j-a)}$	Junction to Ambient on Printed Circuit	75	°C/W
$R_{th(j-l)}$	Junction-leads for 360° Conduction Angle ( $F = 50\text{ Hz}$ )	45	°C/W

**GATE CHARACTERISTICS** (maximum values)

$P_{GM} = 2 \text{ W}$  ( $t_p = 10 \mu\text{s}$ )       $I_{GM} = 1 \text{ A}$  ( $t_p = 10 \mu\text{s}$ )  
 $P_{G(AV)} = 0.1 \text{ W}$        $V_{GM} = 16 \text{ V}$  ( $t_p = 10 \mu\text{s}$ )

**ELECTRICAL CHARACTERISTICS**

Symbol	Test Conditions			Quadrants	Min.	Typ.	Max.	Unit
$I_{GT}$	$T_j = 25 \text{ }^\circ\text{C}$	$V_D = 12 \text{ V}$	$R_L = 33 \text{ } \Omega$	I-II-III-IV			10	mA
$V_{GT}$	$T_j = 25 \text{ }^\circ\text{C}$	$V_D = 12 \text{ V}$	$R_L = 33 \text{ } \Omega$	I-II-III-IV			1.5	V
$V_{GD}$	$T_j = 110 \text{ }^\circ\text{C}$	$V_D = V_{DRM}$	$R_L = 3.3 \text{ k}\Omega$	I-II-III-IV	0.2			V
$I_{H^*}$	$T_j = 25 \text{ }^\circ\text{C}$	$I_T = 100 \text{ mA}$	Gate Open				25	mA
$I_L$	$T_j = 25 \text{ }^\circ\text{C}$	$V_D = 12 \text{ V}$	$I_G = 20 \text{ mA}$	I-II-III-IV			25	mA
$V_{TM}^*$	$T_j = 25 \text{ }^\circ\text{C}$	$I_{TM} = 1.4 \text{ A}$	$t_p = 10 \text{ ms}$				1.8	V
$I_{DRM}^*$	$V_{DRM}$ Specified	$T_j = 25 \text{ }^\circ\text{C}$					0.01	mA
		$T_j = 110 \text{ }^\circ\text{C}$					0.75	
$dv/dt^*$	$T_j = 110 \text{ }^\circ\text{C}$	Gate Open				20		V/ $\mu\text{s}$
$(dv/dt)_c^*$	$T_j = 40 \text{ }^\circ\text{C}$	$V_D = V_{DRM}$	$I_T = 1.4 \text{ A}$			5		V/ $\mu\text{s}$
$t_{gt}$	$T_j = 25 \text{ }^\circ\text{C}$	$V_D = V_{DRM}$	$I_T = 1.4 \text{ A}$	I-II-III-IV		3		$\mu\text{s}$
	$I_G = 100 \text{ mA}$	$di_G/dt = 1 \text{ A}/\mu\text{s}$						

\* For either polarity of electrode A<sub>2</sub> voltage with reference to electrode A<sub>1</sub>.

**PACKAGE MECHANICAL DATA**

TL Plastic

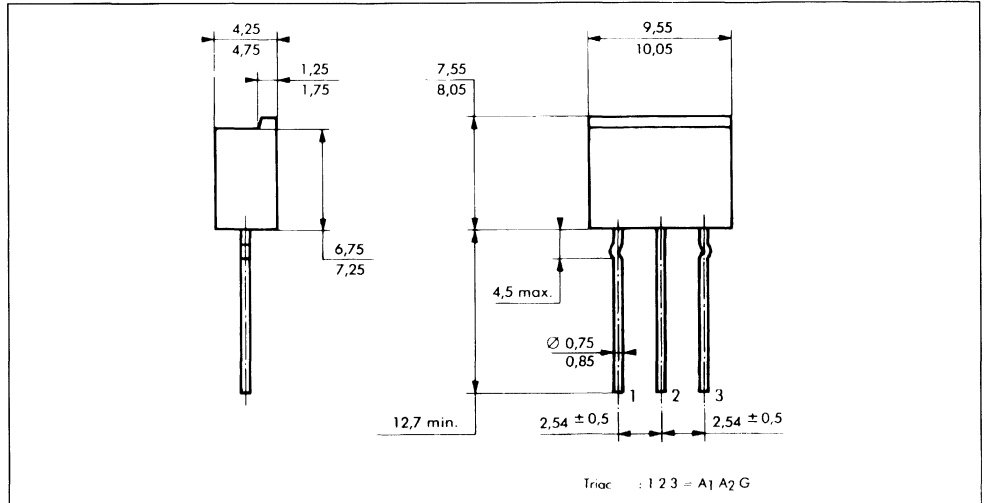

Cooling method : by convection (method A)  
 Marking : type number  
 Weight : 0.8 g.

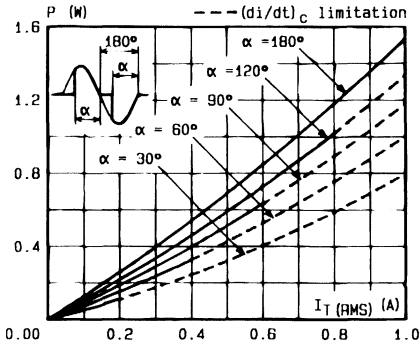

Fig.1 - Maximum mean power dissipation versus RMS on-state current ( $F = 60$  Hz).

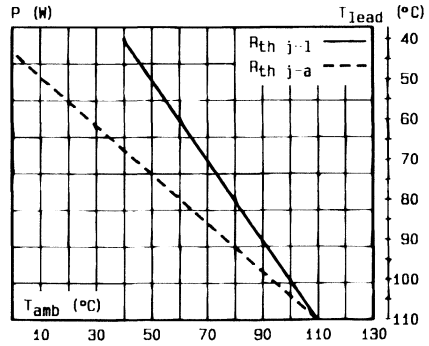

Fig.2 - Correlation between maximum mean power dissipation and maximum allowable temperatures ( $T_{amb}$  and  $T_{lead}$ ), resistances heatsink + contact.

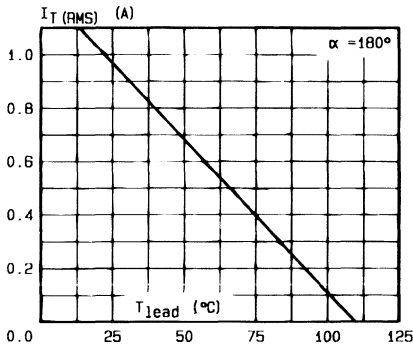

Fig.3 - RMS on-state current versus lead temperature.

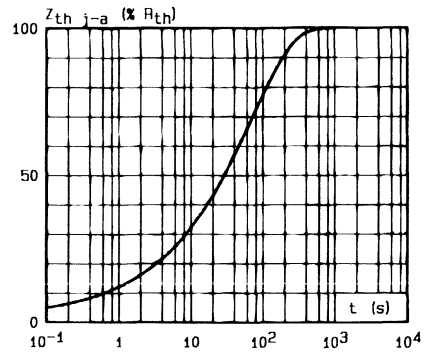

Fig.4 - Thermal transient impedance junction to ambient versus pulse duration.

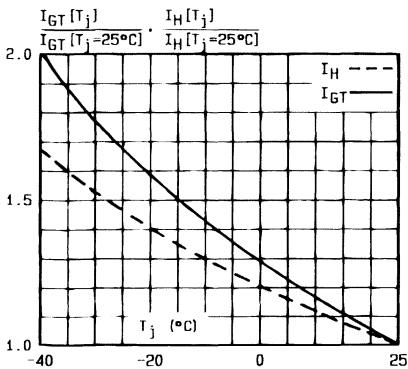

Fig.5 - Relative variation of gate trigger current and holding current versus junction temperature.

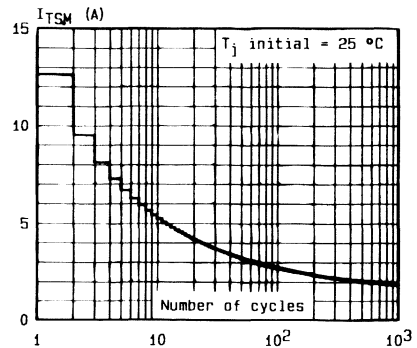

Fig.6 - Non repetitive surge peak on state current versus number of cycles.

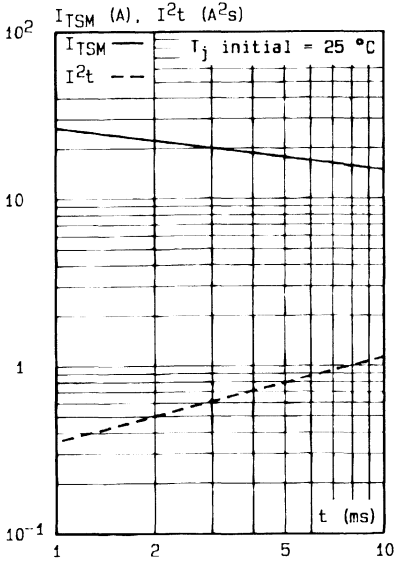

Fig.7 - Non repetitive surge peak on-state current for a sinusoidal pulse with width :  $t \leq 10$  ms, and corresponding value of  $I^2t$ .

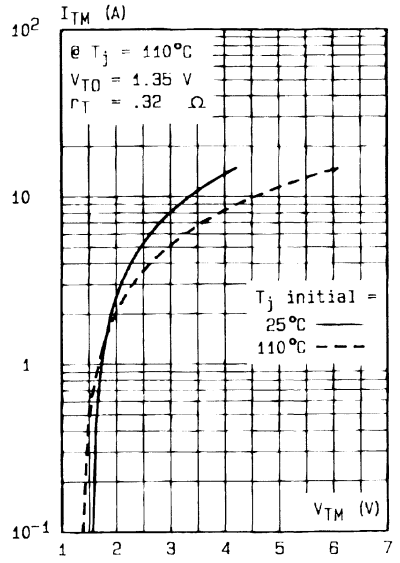

Fig.8 - On-state characteristics (maximum values).

## SENSITIVE GATE TRIACS

- GLASS PASSIVATED CHIP
- HIGH SURGE CURRENT

### DESCRIPTION

Low power triacs suited for 50 and 60 Hz up to 380 V<sub>RMS</sub>.

### APPLICATIONS

- CONTROL SPEED FOR LITTLE MOTORS ; ELECTRIC PUMP OR VENTILATOR, SEWING MACHINE
- RELAY, DETECTOR, ALARM SYSTEM
- ELECTRONIC STARTER FOR LAMP
- HIGH POWER TRIAC DRIVER

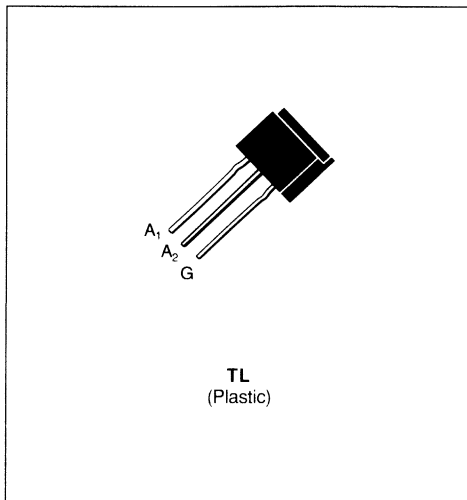

### ABSOLUTE RATINGS (limiting values)

Symbol	Parameter	Value	Unit
$I_{T(RMS)}$	RMS on-state Current (360° conduction angle)	$T_j = 40\text{ °C}$ 1	A
$I_{T(RMS)}$	RMS on-state Current on Printed Circuit (360° conduction angle)	$T_a = 25\text{ °C}$ 0.77	A
$I_{TSM}$	Non Repetitive Surge Peak on-state Current ( $T_j$ initial = 25 °C - Half sine wave)	$t = 8.3\text{ ms}$	16
		$t = 10\text{ ms}$	15
$I^2t$	$I^2t$ Value for Fusing	$t = 10\text{ ms}$	1.125
$di/dt$	Critical Rate of Rise of on-state Current (1)	Repetitive	10
$T_{stg}$ $T_j$	Storage and Operating Junction Temperature Range	- 40 to 150	°C
		- 40 to 110	°C

Symbol	Parameter	TLC111T	TLC221T	TLC331T	TLC381T	Unit
$V_{DRM}$	Repetitive Peak off-state Voltage (2)	200	400	600	700	V

- (1)  $I_G = 50\text{ mA}$   $di/dt = 1\text{ A}/\mu\text{s}$   
 (2)  $T_j = 110\text{ °C}$ .

### THERMAL RESISTANCES

Symbol	Parameter	Value	Unit
$R_{th(j-a)}$	Junction to Ambient on Printed Circuit	75	°C/W
$R_{th(j-l)}$	Junction-leads for 360° Conduction Angle ( $F = 50\text{ Hz}$ )	45	°C/W

**GATE CHARACTERISTICS** (maximum values)

$P_{GM} = 2 \text{ W}$  ( $t_p = 10 \text{ } \mu\text{s}$ )

$I_{GM} = 1 \text{ A}$  ( $t_p = 10 \text{ } \mu\text{s}$ )

$P_{G(AV)} = 0.1 \text{ W}$

$V_{GM} = 16 \text{ V}$  ( $t_p = 10 \text{ } \mu\text{s}$ )

**ELECTRICAL CHARACTERISTICS**

Symbol	Test Conditions			Quadrants	Min.	Typ.	Max.	Unit
$I_{GT}$	$T_j = 25 \text{ }^\circ\text{C}$ Pulse Duration > 20 $\mu\text{s}$	$V_D = 12 \text{ V}$	$R_L = 33 \text{ } \Omega$	I-II-III-IV			5	mA
$V_{GT}$	$T_j = 25 \text{ }^\circ\text{C}$ Pulse Duration > 20 $\mu\text{s}$	$V_D = 12 \text{ V}$	$R_L = 33 \text{ } \Omega$	I-II-III-IV			1.5	V
$V_{GD}$	$T_j = 110 \text{ }^\circ\text{C}$	$V_D = V_{DRM}$	$R_L = 3.3 \text{ k}\Omega$	I-II-III-IV	0.2			V
$I_{H^*}$	$T_j = 25 \text{ }^\circ\text{C}$	$I_T = 100 \text{ mA}$	Gate Open				15	mA
$I_L$	$T_j = 25 \text{ }^\circ\text{C}$ Pulse Duration > 20 $\mu\text{s}$	$V_D = 12 \text{ V}$	$I_G = 10 \text{ mA}$	I-II-III-IV			15	mA
$V_{TM}^*$	$T_j = 25 \text{ }^\circ\text{C}$	$I_{TM} = 1.4 \text{ A}$	$t_p = 10 \text{ ms}$				1.8	V
$I_{DRM}^*$	$V_{DRM}$ Specified	$T_j = 25 \text{ }^\circ\text{C}$					0.01	mA
		$T_j = 110 \text{ }^\circ\text{C}$					0.75	mA
$dv/dt^*$	$T_j = 110 \text{ }^\circ\text{C}$ Gate Open Linear Slope up to $V_D = 67 \% V_{DRM}$					10		V/ $\mu\text{s}$
$(dv/dt)_c^*$	$T_j = 40 \text{ }^\circ\text{C}$ $(di/dt)_c = 0.4 \text{ A/ms}$	$V_D = V_{DRM}$	$I_T = 1.4 \text{ A}$			1		V/ $\mu\text{s}$
$t_{gt}$	$T_j = 25 \text{ }^\circ\text{C}$ $I_G = 100 \text{ mA}$	$V_D = V_{DRM}$ $di_G/dt = 1 \text{ A}/\mu\text{s}$	$I_T = 1.4 \text{ A}$	I-II-III-IV		3		$\mu\text{s}$

\* For either polarity of electrode  $A_2$  voltage with reference to electrode  $A_1$ .

**PACKAGE MECHANICAL DATA**

TL Plastic

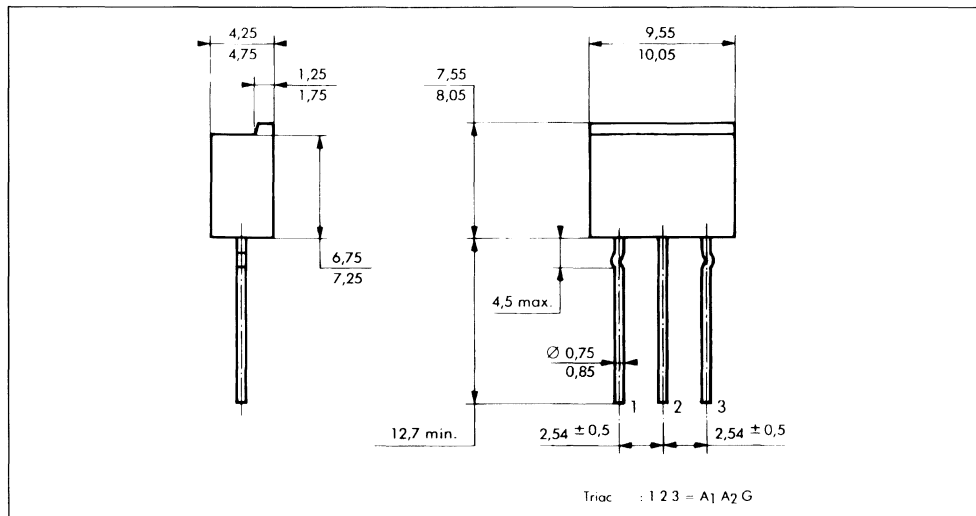

Cooling method : by convection (method A)

Marking : type number

Weight : 0.8 g.

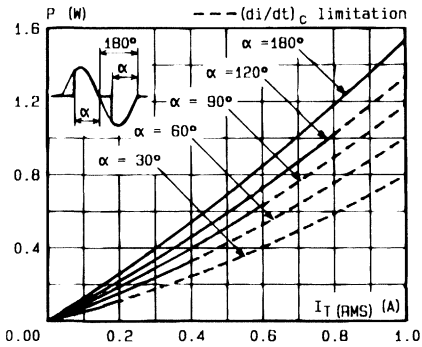

Fig. 1 - Maximum mean power dissipation versus RMS on-state current (F = 60 Hz).

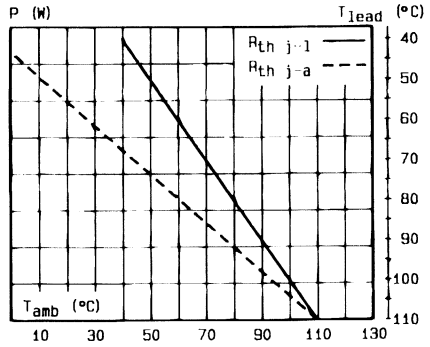

Fig. 2 - Correlation between maximum mean power dissipation and maximum allowable temperatures (T<sub>amb</sub> and T<sub>lead</sub>). resistances heatsink + contact.

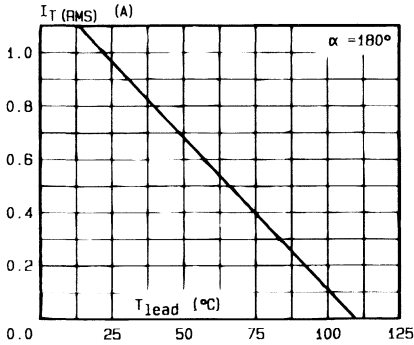

Fig. 3 - RMS on-state current versus lead temperature.

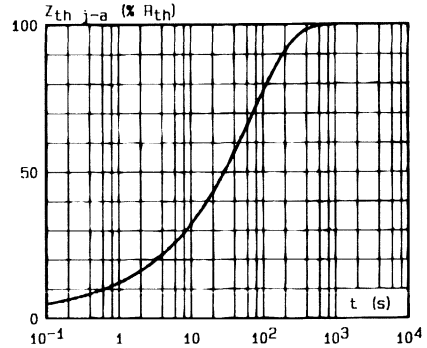

Fig. 4 - Thermal transient impedance junction to ambient versus pulse duration.

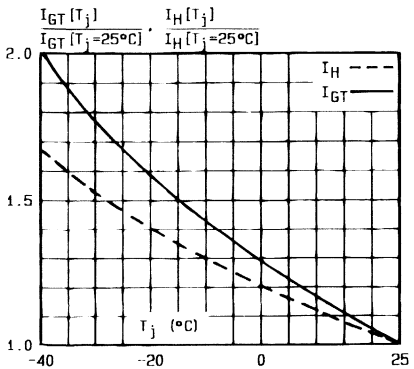

Fig. 5 - Relative variation of gate trigger current and holding current versus junction temperature.

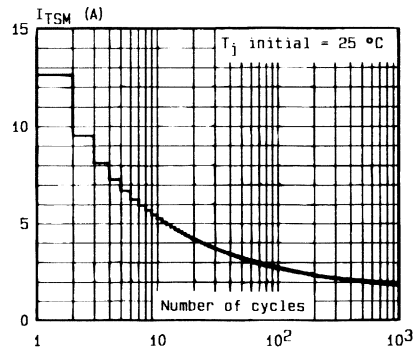

Fig. 6 - Non repetitive surge peak on state current versus number of cycles.

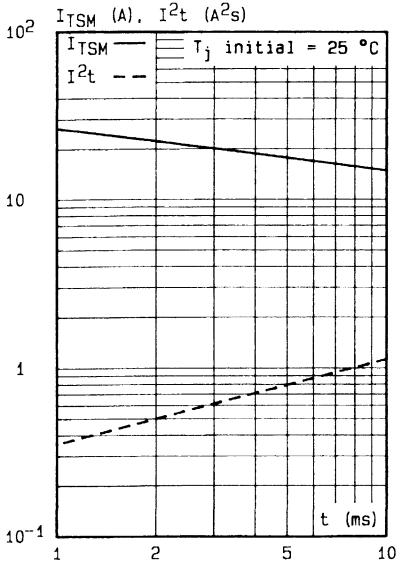

Fig.7 - Non repetitive surge peak on-state current for a sinusoidal pulse with width:  $t \leq 10$  ms, and corresponding value of  $I^2t$ .

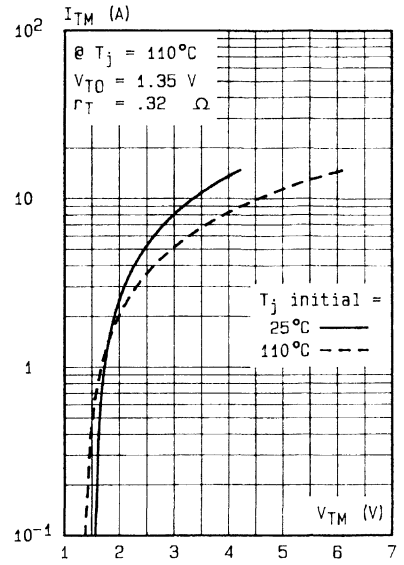

Fig.8 - On-state characteristics (maximum values).



## SENSITIVE GATE TRIACS

- GLASS PASSIVATED CHIP
- HIGH SURGE CURRENT

### DESCRIPTION

Low power triacs suited for 50 and 60 Hz up to 380 V<sub>RMS</sub>.

### APPLICATIONS

- CONTROL SPEED FOR LITTLE MOTORS ;  
ELECTRIC PUMP OR VENTILATOR, SEWING MACHINE
- RELAY, DETECTOR, ALARM SYSTEM
- ELECTRONIC STARTER FOR LAMP
- HIGH POWER TRIAC DRIVER

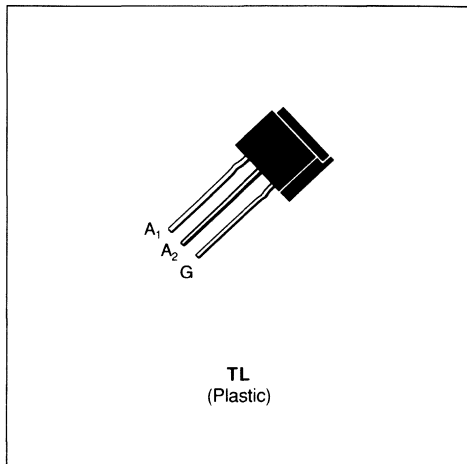

### ABSOLUTE RATINGS (limiting values)

Symbol	Parameter	Value	Unit
$I_{T(RMS)}$	RMS on-state Current (360° conduction angle) $T_j = 40\text{ °C}$	3	A
$I_{T(RMS)}$	RMS on-state Current on Printed Circuit (360° conduction angle) $T_a = 25\text{ °C}$	1.3 (3)	A
$I_{TSM}$	Non Repetitive Surge Peak on-state Current ( $T_j$ initial = 25 °C - Half sine wave)	$t = 8.3\text{ ms}$	31.5
		$t = 10\text{ ms}$	30
$I^2t$	$I^2t$ Value for Fusing $t = 10\text{ ms}$	4.5	A <sup>2</sup> s
$di/dt$	Critical Rate of Rise of on-state Current (1) Repetitive	10	A/ $\mu$ s
$T_{stg}$ $T_j$	Storage and Operating Junction Temperature Range	- 40 to 150 - 40 to 110	°C °C

Symbol	Parameter	TLC116A	TLC226A	TLC336A	TLC386A	Unit
$V_{DRM}$	Repetitive Peak off-state Voltage (2)	200	400	600	700	V

(1)  $I_G = 250\text{ mA}$   $di/dt = 1\text{ A}/\mu\text{s}$

(2)  $T_j = 110\text{ °C}$ .

(3) With Cu surface = 1 cm<sup>2</sup>.

### THERMAL RESISTANCES

Symbol	Parameter	Value	Unit
$R_{th(j-a)}$	Junction to Ambient on Printed Circuit	50 (1)	°C/W
$R_{th(j-l)}$	Junction-leads for 360° Conduction Angle (F = 50 Hz)	15	°C/W

(1) With Cu surface = 1 cm<sup>2</sup>.

**GATE CHARACTERISTICS** (maximum values)

$P_{GM} = 2 \text{ W}$  ( $t_p = 10 \mu\text{s}$ )

$I_{GM} = 1 \text{ A}$  ( $t_p = 10 \mu\text{s}$ )

$P_{G(AV)} = 0.1 \text{ W}$

$V_{GM} = 16 \text{ V}$  ( $t_p = 10 \mu\text{s}$ )

**ELECTRICAL CHARACTERISTICS**

Symbol	Test Conditions	Quadrants	Min.	Typ.	Max.	Unit
$I_{GT}$	$T_j = 25 \text{ }^\circ\text{C}$ $V_D = 12 \text{ V}$ $R_L = 33 \text{ } \Omega$ Pulse Duration > 20 $\mu\text{s}$	I-II-III			10	mA
		IV			25	
$V_{GT}$	$T_j = 25 \text{ }^\circ\text{C}$ $V_D = 12 \text{ V}$ $R_L = 33 \text{ } \Omega$ Pulse Duration > 20 $\mu\text{s}$	I-II-III-IV			1.5	V
$V_{GD}$	$T_j = 110 \text{ }^\circ\text{C}$ $V_D = V_{DRM}$ $R_L = 3.3 \text{ k}\Omega$	I-II-III-IV	0.2			V
$I_H^*$	$T_j = 25 \text{ }^\circ\text{C}$ $I_T = 100 \text{ mA}$ Gate Open				25	mA
$I_L$	$T_j = 25 \text{ }^\circ\text{C}$ $V_D = 12 \text{ V}$ $I_G = 50 \text{ mA}$ Pulse Duration > 20 $\mu\text{s}$	I-II-III-IV			25	mA
$V_{TM}^*$	$T_j = 25 \text{ }^\circ\text{C}$ $I_{TM} = 4 \text{ A}$ $t_p = 10 \text{ ms}$				1.85	V
$I_{DRM}^*$	$V_{DRM}$ Specified	$T_j = 25 \text{ }^\circ\text{C}$			0.01	mA
		$T_j = 110 \text{ }^\circ\text{C}$			0.75	
$dv/dt^*$	$T_j = 110 \text{ }^\circ\text{C}$ Gate Open Linear Slope up to $V_D = 67 \text{ } \% V_{DRM}$			20		V/ $\mu\text{s}$
$(dv/dt)_c^*$	$T_j = 40 \text{ }^\circ\text{C}$ $V_D = V_{DRM}$ $I_T = 4 \text{ A}$ $(di/dt)_c = 1.3 \text{ A/ms}$			5		V/ $\mu\text{s}$
$t_{gt}$	$T_j = 25 \text{ }^\circ\text{C}$ $V_D = V_{DRM}$ $I_G = 100 \text{ mA}$ $di_G/dt = 1 \text{ A}/\mu\text{s}$	I-II-III-IV		3		$\mu\text{s}$

\* For either polarity of electrode  $A_2$  voltage with reference to electrode  $A_1$ .

**PACKAGE MECHANICAL DATA**

TL Plastic

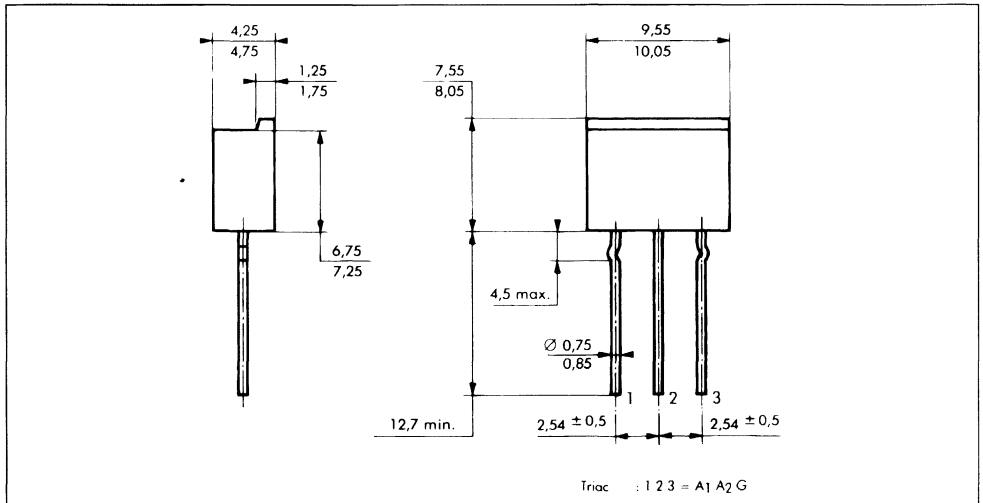

Cooling method : by convection (method A)

Marking : type number

Weight : 0.8 g.

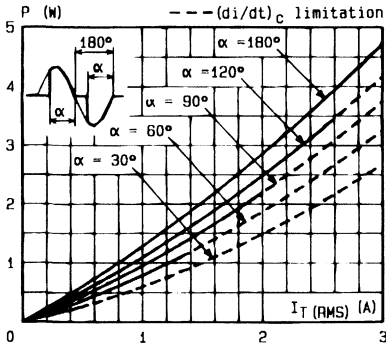

Fig.1 - Maximum mean power dissipation versus RMS on-state current.

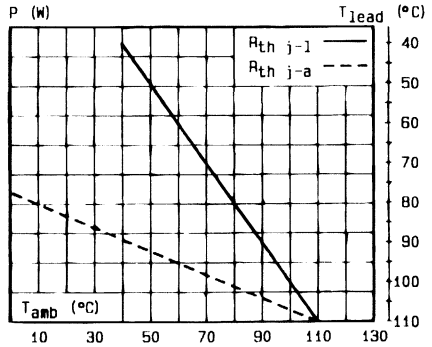

Fig.2 - Correlation between maximum mean power dissipation and maximum allowable temperatures ( $T_{amb}$  and  $T_{lead}$ ). resistances heatsink + contact.

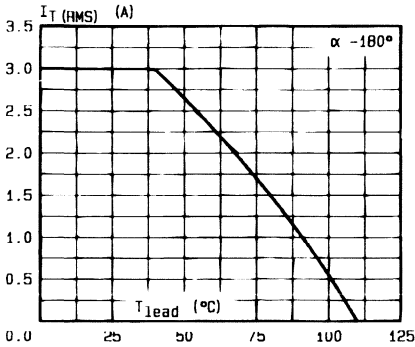

Fig.3 - RMS on-state current versus lead temperature.

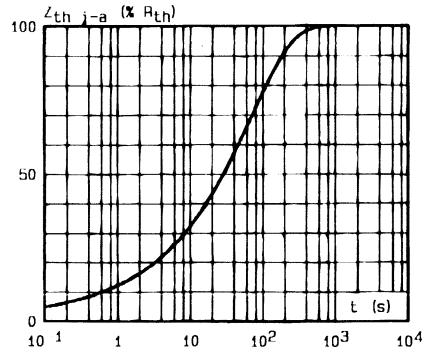

Fig.4 - Thermal transient impedance junction to ambient versus pulse duration.

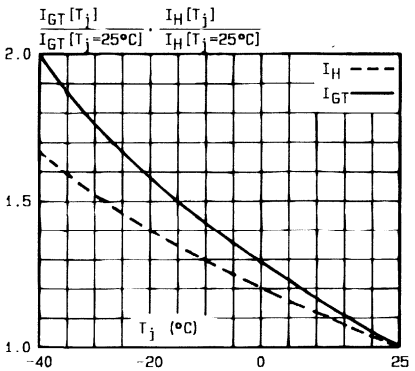

Fig.5 - Relative variation of gate trigger current and holding current versus junction temperature.

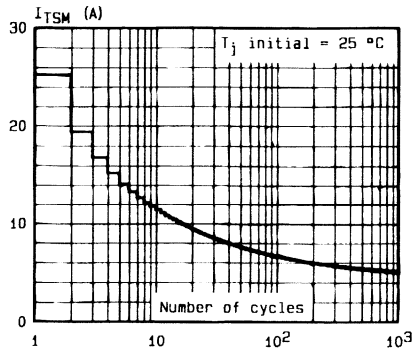

Fig.6 - Non repetitive surge peak on-state current versus number of cycles.

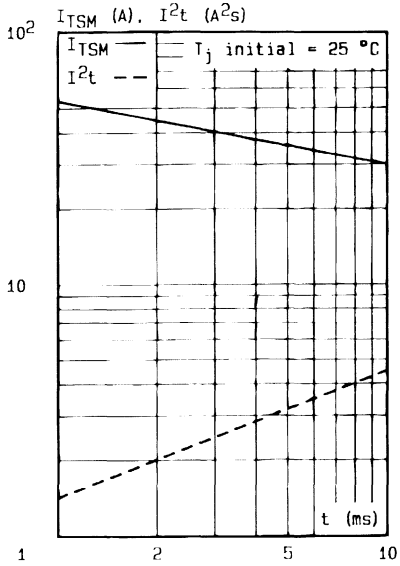

Fig.7 - Non repetitive surge peak on-state current for a sinusoidal pulse with width :  $t \leq 10$  ms, and corresponding value of  $I^2t$ .

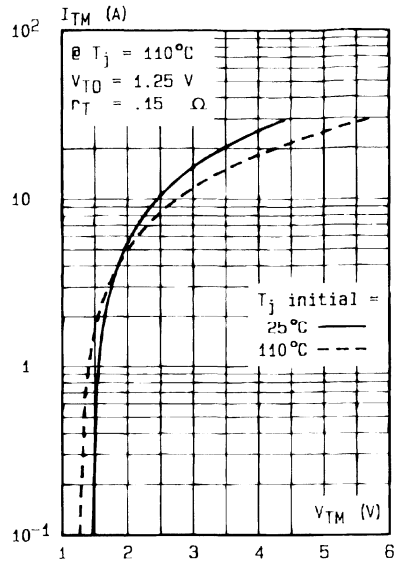

Fig.8 - On-state characteristics (maximum values).



**TRIACS**

- GLASS PASSIVATED CHIP
- HIGH SURGE CURRENT

**DESCRIPTION**

Low power triacs suited for 50 and 60 Hz up to 380 V<sub>RMS</sub>.

**APPLICATIONS**

- CONTROL SPEED FOR LITTLE MOTORS ; ELECTRIC PUMP OR VENTILATOR, SEWING MACHINE
- RELAY, DETECTOR, ALARM SYSTEM
- ELECTRONIC STARTER FOR LAMP
- HIGH POWER TRIAC DRIVER

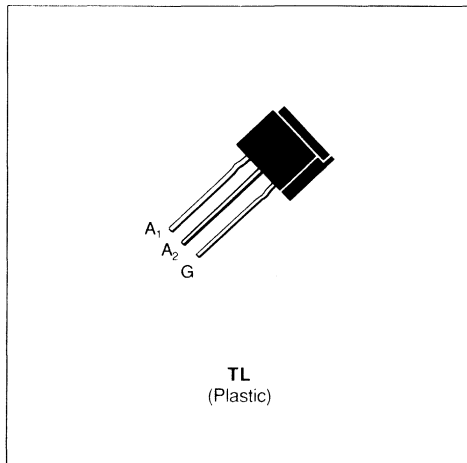

**ABSOLUTE RATINGS** (limiting values)

Symbol	Parameter		Value	Unit
$I_{T(RMS)}$	RMS on-state Current (360° conduction angle)	$T_j = 40\text{ °C}$	3	A
$I_{T(RMS)}$	RMS on-state Current on Printed Circuit (360° conduction angle)	$T_a = 25\text{ °C}$	1.3 (3)	A
$I_{TSM}$	Non Repetitive Surge Peak on-state Current ( $T_j$ initial = 25 °C - Half sine wave)	$t = 8.3\text{ ms}$	31.5	A
		$t = 10\text{ ms}$	30	
$I^2t$	$I^2t$ Value for Fusing	$t = 10\text{ ms}$	4.5	A <sup>2</sup> s
$di/dt$	Critical Rate of Rise of on-state Current (1)	Repetitive	10	A/ $\mu$ s
$T_{stg}$	Storage and Operating Junction Temperature Range		- 40 to 150	°C
$T_j$			- 40 to 110	°C

Symbol	Parameter	TLC116B	TLC226B	TLC336B	TLC386B	Unit
$V_{DRM}$	Repetitive Peak off-state Voltage (2)	200	400	600	700	V

(1)  $I_G = 500\text{ mA}$   $di_G/dt = 1\text{ A}/\mu\text{s}$

(2)  $T_j = 110\text{ °C}$ .

(3) With Cu surface = 1 cm<sup>2</sup>.

**THERMAL RESISTANCES**

Symbol	Parameter	Value	Unit
$R_{th(j-a)}$	Junction to Ambient on Printed Circuit	50 (1)	°C/W
$R_{th(j-l)}$	Junction-leads for 360° Conduction Angle (F = 50 Hz)	15	°C/W

(1) With Cu surface = 1 cm<sup>2</sup>.

**GATE CHARACTERISTICS** (maximum values)

$P_{GM} = 2 \text{ W}$  ( $t_p = 10 \mu\text{s}$ )       $I_{GM} = 1 \text{ A}$  ( $t_p = 10 \mu\text{s}$ )  
 $P_{G(AV)} = 0.1 \text{ W}$        $V_{GM} = 16 \text{ V}$  ( $t_p = 10 \mu\text{s}$ )

**ELECTRICAL CHARACTERISTICS**

Symbol	Test Conditions			Quadrants	Min.	Typ.	Max.	Unit
$I_{GT}$	$T_j = 25 \text{ }^\circ\text{C}$ Pulse Duration > 20 $\mu\text{s}$	$V_D = 12 \text{ V}$	$R_L = 33 \text{ } \Omega$	I-II-III			25	mA
				IV			50	
$V_{GT}$	$T_j = 25 \text{ }^\circ\text{C}$ Pulse Duration > 20 $\mu\text{s}$	$V_D = 12 \text{ V}$	$R_L = 33 \text{ } \Omega$	I-II-III-IV			1.5	V
$V_{GD}$	$T_j = 110 \text{ }^\circ\text{C}$	$V_D = V_{DRM}$	$R_L = 3.3 \text{ k}\Omega$	I-II-III-IV	0.2			V
$I_{H^*}$	$T_j = 25 \text{ }^\circ\text{C}$	$I_T = 100 \text{ mA}$	Gate Open			8		mA
$I_L$	$T_j = 25 \text{ }^\circ\text{C}$ Pulse Duration > 20 $\mu\text{s}$	$V_D = 12 \text{ V}$	$I_G = 100 \text{ mA}$	I-II-III-IV		8		mA
$V_{TM}^*$	$T_j = 25 \text{ }^\circ\text{C}$	$I_{TM} = 4 \text{ A}$	$t_p = 10 \text{ ms}$				1.85	V
$I_{DRM}^*$	$V_{DRM}$ Specified		$T_j = 25 \text{ }^\circ\text{C}$				0.01	mA
							0.75	
$dv/dt^*$	$T_j = 110 \text{ }^\circ\text{C}$	Gate Open			20			V/ $\mu\text{s}$
	Linear Slope up to $V_D = 67\% V_{DRM}$							
$(dv/dt)_C^*$	$T_j = 40 \text{ }^\circ\text{C}$ $(di/dt)_C = 1.3 \text{ A/ms}$	$V_D = V_{DRM}$	$I_T = 4 \text{ A}$		5			V/ $\mu\text{s}$
$t_{gt}$	$T_j = 25 \text{ }^\circ\text{C}$ $I_G = 100 \text{ mA}$	$V_D = V_{DRM}$ $di_G/dt = 1 \text{ A}/\mu\text{s}$	$I_T = 4 \text{ A}$	I-II-III-IV		3		$\mu\text{s}$

\* For either polarity of electrode  $A_2$  voltage with reference to electrode  $A_1$ .

**PACKAGE MECHANICAL DATA**

TL Plastic

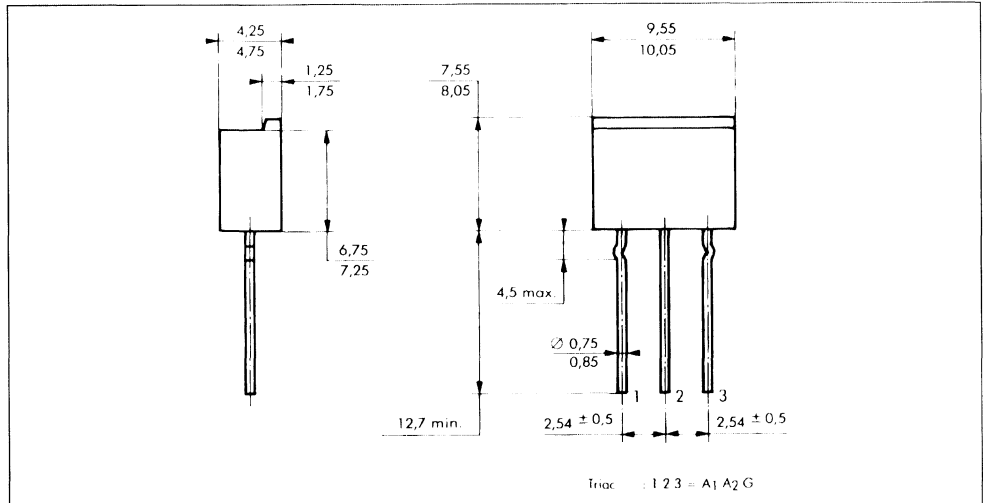

Cooling method : by convection (method A)  
 Marking : type number  
 Weight : 0.8 g.

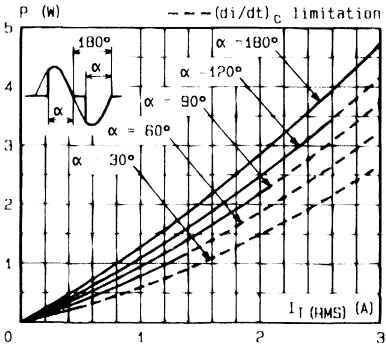

Fig. 1 - Maximum mean power dissipation versus RMS on-state current.

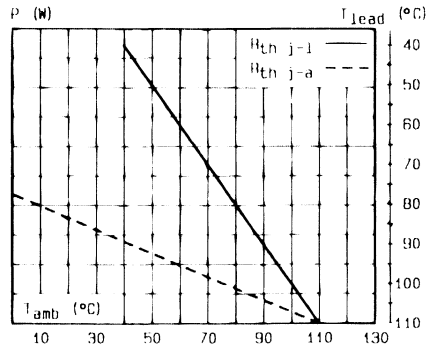

Fig. 2 - Correlation between maximum mean power dissipation and maximum allowable temperatures ( $I_{amb}$  and  $I_{lead}$ ).

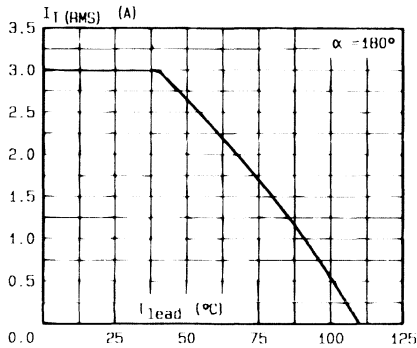

Fig. 3 - RMS on-state current versus lead temperature.

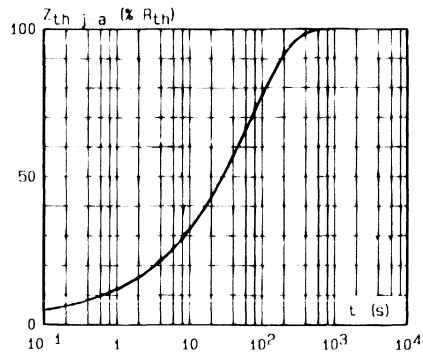

Fig. 4 - Thermal transient impedance junction to ambient pulse duration.

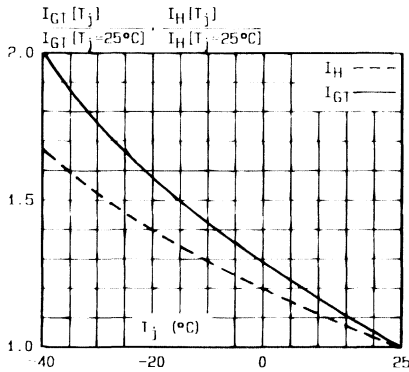

Fig. 5 - Relative variation of gate trigger current and holding current versus junction temperature.

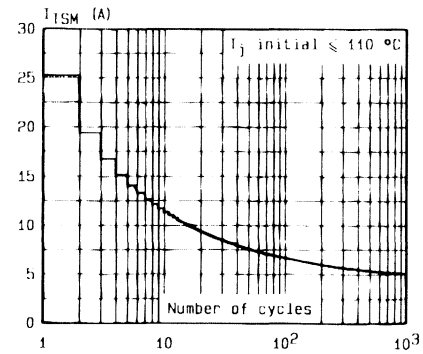

Fig. 6 - Non repetitive surge peak on state current versus number of cycles.

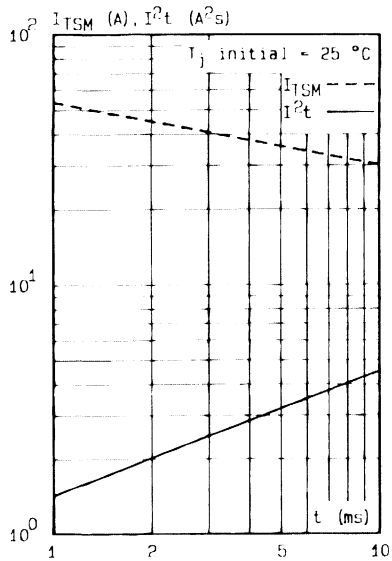

Fig.7 - Non repetitive surge peak on-state current for a sinusoidal pulse with width:  $t \leq 10\text{ms}$ , and corresponding value of  $I^2t$ .

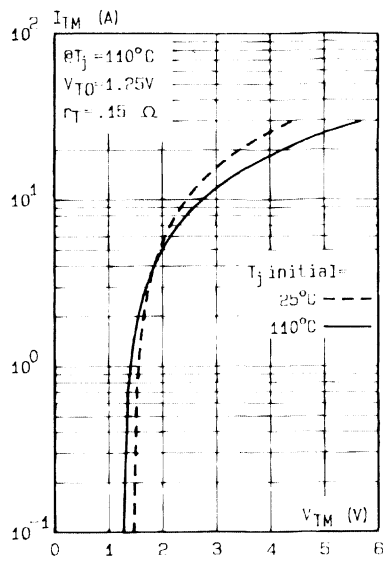

Fig.8 - On-state characteristic (maximum values).





**SENSITIVE GATE TRIACS**

- GLASS PASSIVATED CHIP
- HIGH SURGE CURRENT

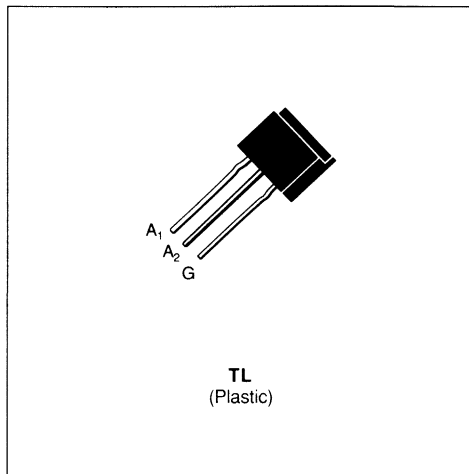

**DESCRIPTION**

Low power triacs suited for 50 and 60 Hz up to 380 V<sub>RMS</sub>.

**APPLICATIONS**

- CONTROL SPEED FOR LITTLE MOTORS ; ELECTRIC PUMP OR VENTILATOR, SEWING MACHINE
- RELAY, DETECTOR, ALARM SYSTEM
- ELECTRONIC STARTER FOR LAMP
- HIGH POWER TRIAC DRIVER

**ABSOLUTE RATINGS** (limiting values)

Symbol	Parameter		Value	Unit
$I_{T(RMS)}$	RMS on-state Current (360° conduction angle)	$T_j = 40\text{ °C}$	3	A
$I_{T(RMS)}$	RMS on-state Current on Printed Circuit (360° conduction angle)	$T_a = 25\text{ °C}$	1.3 (3)	A
$I_{TSM}$	Non Repetitive Surge Peak on-state Current ( $T_j$ initial = 25 °C - Half sine wave)	$t = 8.3\text{ ms}$	31.5	A
		$t = 10\text{ ms}$	30	
$I^2t$	$I^2t$ Value for Fusing	$t = 10\text{ ms}$	4.5	A <sup>2</sup> s
di/dt	Critical Rate of Rise of on-state Current (1)	Repetitive	10	A/μs
$T_{stg}$ $T_j$	Storage and Operating Junction Temperature Range		- 40 to 150	°C
			- 40 to 110	°C

Symbol	Parameter	TLC116D	TLC226D	TLC336D	TLC386D	Unit
$V_{DRM}$	Repetitive Peak off-state Voltage (2)	200	400	600	700	V

(1)  $I_G = 100\text{ mA}$      $di_G/dt = 1\text{ A/μs}$

(2)  $T_j = 110\text{ °C}$ .

(3) With Cu surface = 1 cm<sup>2</sup>.

**THERMAL RESISTANCES**

Symbol	Parameter	Value	Unit
$R_{th(j-a)}$	Junction to Ambient on Printed Circuit	50 (1)	°C/W
$R_{th(j-l)}$	Junction-leads for 360° Conduction Angle (F = 50 Hz)	15	°C/W

(1) With Cu surface = 1 cm<sup>2</sup>.

**GATE CHARACTERISTICS** (maximum values)

$P_{GM} = 2 \text{ W}$  ( $t_p = 10 \mu\text{s}$ )       $I_{GM} = 1 \text{ A}$  ( $t_p = 10 \mu\text{s}$ )  
 $P_{G(AV)} = 0.1 \text{ W}$        $V_{GM} = 16 \text{ V}$  ( $t_p = 10 \mu\text{s}$ )

**ELECTRICAL CHARACTERISTICS**

Symbol	Test Conditions			Quadrants	Min.	Typ.	Max.	Unit
$I_{GT}$	$T_j = 25 \text{ }^\circ\text{C}$ Pulse Duration > 20 $\mu\text{s}$	$V_D = 12 \text{ V}$	$R_L = 33 \text{ } \Omega$	I-II-III			5	mA
				IV			10	
$V_{GT}$	$T_j = 25 \text{ }^\circ\text{C}$ Pulse Duration > 20 $\mu\text{s}$	$V_D = 12 \text{ V}$	$R_L = 33 \text{ } \Omega$	I-II-III-IV			1.5	V
$V_{GD}$	$T_j = 110 \text{ }^\circ\text{C}$	$V_D = V_{DRM}$	$R_L = 3.3 \text{ k}\Omega$	I-II-III-IV	0.2			V
$I_H^*$	$T_j = 25 \text{ }^\circ\text{C}$	$I_T = 100 \text{ mA}$	Gate Open				15	mA
$I_L$	$T_j = 25 \text{ }^\circ\text{C}$ Pulse Duration > 20 $\mu\text{s}$	$V_D = 12 \text{ V}$	$I_G = 20 \text{ mA}$	I-II-III-IV			15	mA
$V_{TM}^*$	$T_j = 25 \text{ }^\circ\text{C}$	$I_{TM} = 4 \text{ A}$	$t_p = 10 \text{ ms}$				1.85	V
$I_{DRM}^*$	$V_{DRM}$ Specified						0.01	mA
							$T_j = 110 \text{ }^\circ\text{C}$	
$dv/dt^*$	$T_j = 110 \text{ }^\circ\text{C}$ Linear Slope up to $V_D = 67\% V_{DRM}$	Gate Open				10		V/ $\mu\text{s}$
$(dv/dt)_c^*$	$T_j = 40 \text{ }^\circ\text{C}$ $(di/dt)_c = 1.3 \text{ A/ms}$	$V_D = V_{DRM}$	$I_T = 4 \text{ A}$			1		V/ $\mu\text{s}$
$t_{gt}$	$T_j = 25 \text{ }^\circ\text{C}$	$V_D = V_{DRM}$ $di_G/dt = 1 \text{ A}/\mu\text{s}$	$I_T = 4 \text{ A}$	I-II-III-IV		3		$\mu\text{s}$

\* For either polarity of electrode  $A_2$  voltage with reference to electrode  $A_1$ .

**PACKAGE MECHANICAL DATA**

TL Plastic

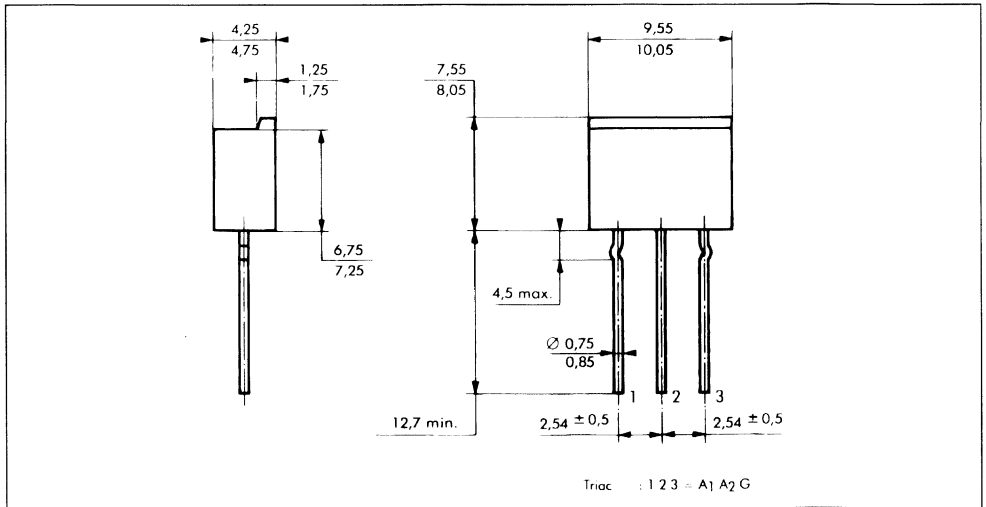

Cooling method : by convection (method A)  
 Marking : type number  
 Weight : 0.8 g.

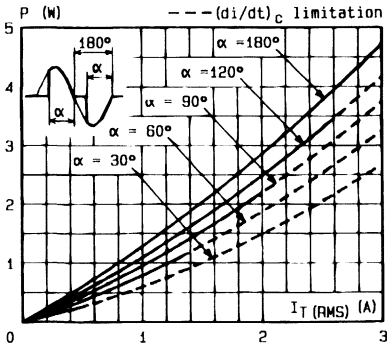

Fig. 1 - Maximum mean power dissipation versus RMS on-state current.

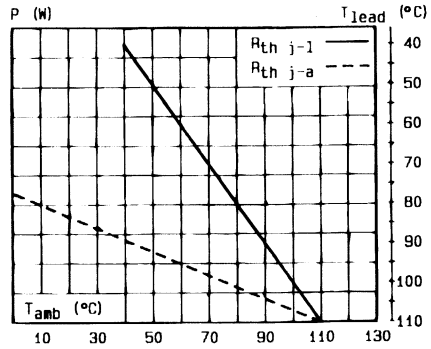

Fig. 2 - Correlation between maximum mean power dissipation and maximum allowable temperatures ( $T_{amb}$  and  $T_{lead}$ ), resistances heatsink + contact.

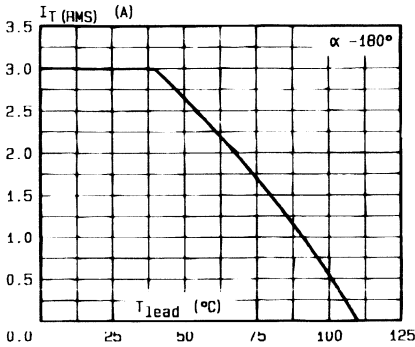

Fig. 3 - RMS on-state current versus lead temperature.

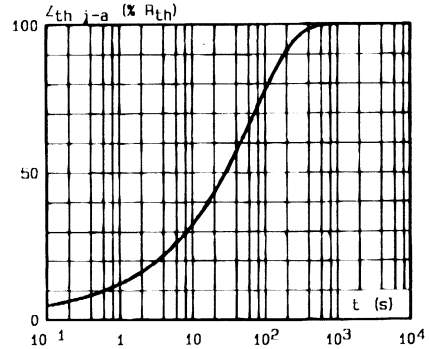

Fig. 4 - Thermal transient impedance junction to ambient versus pulse duration.

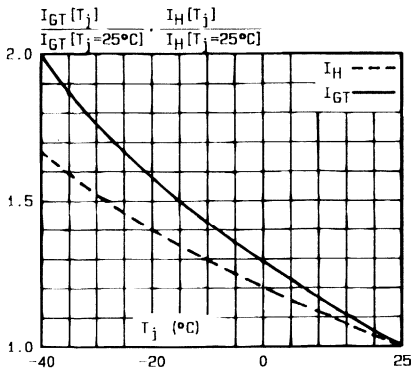

Fig. 5 - Relative variation of gate trigger current and holding current versus junction temperature.

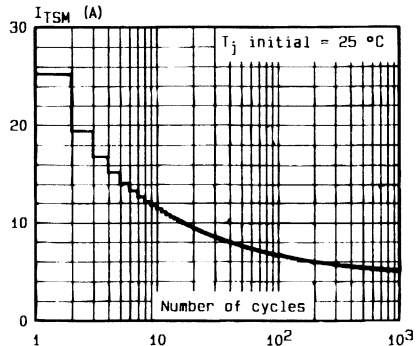

Fig. 6 - Non repetitive surge peak on-state current versus number of cycles.

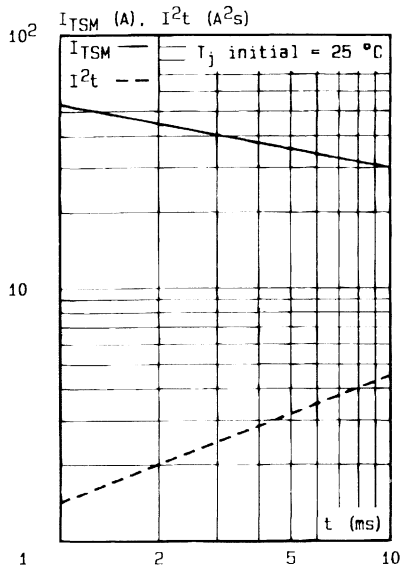

Fig.7 - Non repetitive surge peak on-state current for a sinusoidal pulse with width :  $t \leq 10$  ms, and corresponding value of  $I^2t$ .

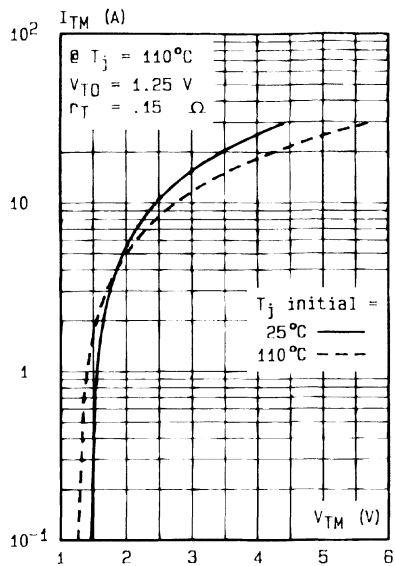

Fig.8 - On-state characteristics (maximum values).



**SENSITIVE GATE TRIACS**

- GLASS PASSIVATED CHIP
- HIGH SURGE CURRENT

**DESCRIPTION**

Low power triacs suited for 50 and 60 Hz up to 380 V<sub>RMS</sub>.

**APPLICATIONS**

- CONTROL SPEED FOR LITTLE MOTORS ; ELECTRIC PUMP OR VENTILATOR, SEWING MACHINE
- RELAY, DETECTOR, ALARM SYSTEM
- ELECTRONIC STARTER FOR LAMP
- HIGH POWER TRIAC DRIVER

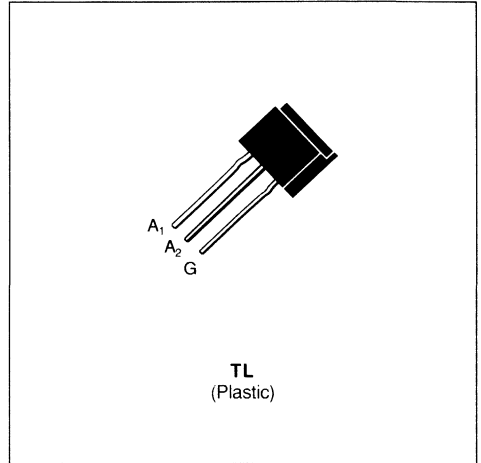

**ABSOLUTE RATINGS** (limiting values)

Symbol	Parameter		Value	Unit
$I_{T(RMS)}$	RMS on-state Current (360° conduction angle)	$T_I = 40\text{ °C}$	3	A
$I_{T(RMS)}$	RMS on-state Current on Printed Circuit (360° conduction angle)	$T_a = 25\text{ °C}$	1.3 (3)	A
$I_{TSM}$	Non Repetitive Surge Peak on-state Current ( $T_j$ initial = 25 °C - Half sine wave)	$t = 8.3\text{ ms}$	31.5	A
		$t = 10\text{ ms}$	30	
$I^2t$	$I^2t$ Value for Fusing	$t = 10\text{ ms}$	4.5	A <sup>2</sup> s
di/dt	Critical Rate of Rise of on-state Current (1)	Repetitive	10	A/μs
$T_{stg}$ $T_j$	Storage and Operating Junction Temperature Range		- 40 to 150	°C
			- 40 to 110	°C

Symbol	Parameter	TLC116S	TLC226S	TLC336S	TLC386S	Unit
$V_{DRM}$	Repetitive Peak off-state Voltage (2)	200	400	600	700	V

(1)  $I_G = 100\text{ mA}$      $di/dt = 1\text{ A}/\mu\text{s}$

(2)  $T_j = 110\text{ °C}$ .

(3) With Cu surface = 1 cm<sup>2</sup>.

**THERMAL RESISTANCES**

Symbol	Parameter	Value	Unit
$R_{th(j-a)}$	Junction to Ambient on Printed Circuit	50 (1)	°C/W
$R_{th(j-l)}$	Junction-leads for 360° Conduction Angle (F = 50 Hz)	15	°C/W

(1) With Cu surface = 1 cm<sup>2</sup>.

**GATE CHARACTERISTICS** (maximum values)

$P_{GM} = 2 \text{ W}$  ( $t_p = 10 \mu\text{s}$ )       $I_{GM} = 1 \text{ A}$  ( $t_p = 10 \mu\text{s}$ )  
 $P_{G(AV)} = 0.1 \text{ W}$        $V_{GM} = 16 \text{ V}$  ( $t_p = 10 \mu\text{s}$ )

**ELECTRICAL CHARACTERISTICS**

Symbol	Test Conditions	Quadrants	Min.	Typ.	Max.	Unit
$I_{GT}$	$T_j = 25 \text{ }^\circ\text{C}$ $V_D = 12 \text{ V}$ $R_L = 33 \text{ } \Omega$ Pulse Duration > 20 $\mu\text{s}$	I-II-III-IV			10	mA
$V_{GT}$	$T_j = 25 \text{ }^\circ\text{C}$ $V_D = 12 \text{ V}$ $R_L = 33 \text{ } \Omega$ Pulse Duration > 20 $\mu\text{s}$	I-II-III-IV			1.5	V
$V_{GD}$	$T_j = 110 \text{ }^\circ\text{C}$ $V_D = V_{DRM}$ $R_L = 3.3 \text{ k}\Omega$	I-II-III-IV	0.2			V
$I_H^*$	$T_j = 25 \text{ }^\circ\text{C}$ $I_T = 100 \text{ mA}$ Gate Open				25	mA
$I_L$	$T_j = 25 \text{ }^\circ\text{C}$ $V_D = 12 \text{ V}$ $I_G = 20 \text{ mA}$ Pulse Duration > 20 $\mu\text{s}$	I-II-III-IV			25	mA
$V_{TM}^*$	$T_j = 25 \text{ }^\circ\text{C}$ $I_{TM} = 4 \text{ A}$ $t_p = 10 \text{ ms}$				1.85	V
$I_{DRM}^*$	$V_{DRM}$ Specified	$T_j = 25 \text{ }^\circ\text{C}$			0.01	mA
		$T_j = 110 \text{ }^\circ\text{C}$			0.75	
$dv/dt^*$	$T_j = 110 \text{ }^\circ\text{C}$ Gate Open Linear Slope up to $V_D = 67 \% V_{DRM}$			20		V/ $\mu\text{s}$
$(dv/dt)_c^*$	$T_j = 40 \text{ }^\circ\text{C}$ $V_D = V_{DRM}$ $I_T = 4 \text{ A}$ $(di/dt)_c = 1.3 \text{ A/ms}$			5		V/ $\mu\text{s}$
$t_{gt}$	$T_j = 25 \text{ }^\circ\text{C}$ $V_D = V_{DRM}$ $I_T = 4 \text{ A}$ $I_G = 100 \text{ mA}$ $di_G/dt = 1 \text{ A}/\mu\text{s}$	I-II-III-IV		3		$\mu\text{s}$

\* For either polarity of electrode  $A_2$  voltage with reference to electrode  $A_1$ .

**PACKAGE MECHANICAL DATA**

TL Plastic

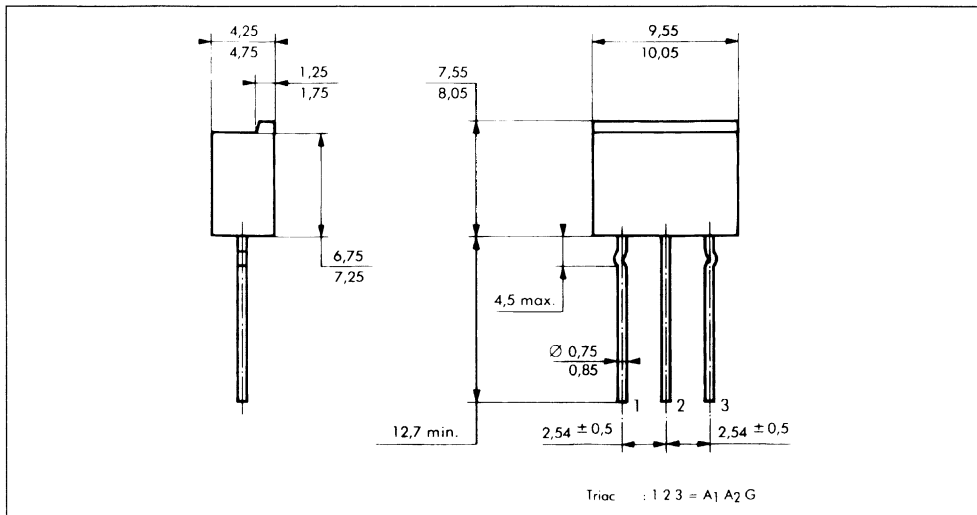

Cooling method : by convection (method A)  
 Marking : type number  
 Weight : 0.8 g.

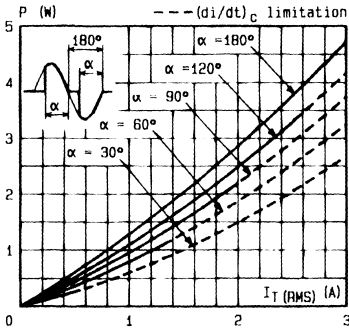

Fig. 1 - Maximum mean power dissipation versus RMS on-state current.

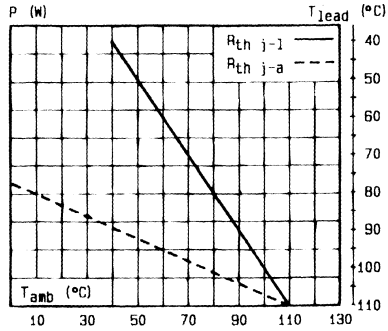

Fig. 2 - Correlation between maximum mean power dissipation and maximum allowable temperatures ( $T_{amb}$  and  $T_{lead}$ ) resistances heatsink + contact.

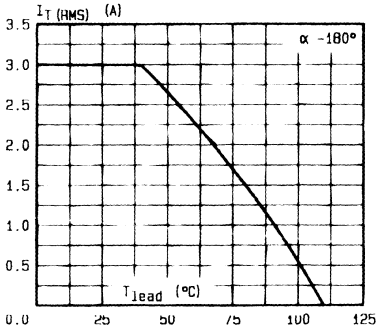

Fig. 3 - RMS on-state current versus lead temperature.

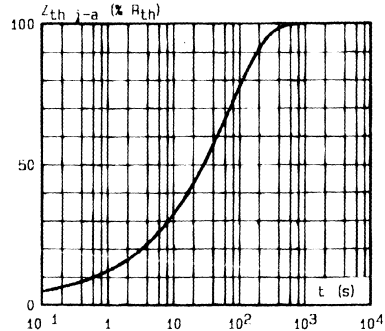

Fig. 4 - Thermal transient impedance junction to ambient versus pulse duration.

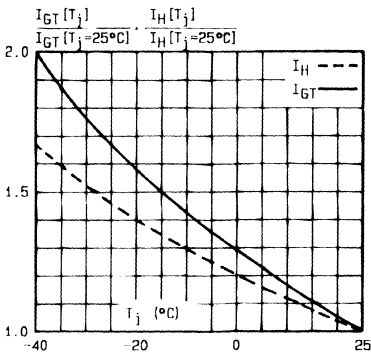

Fig. 5 - Relative variation of gate trigger current and holding current versus junction temperature.

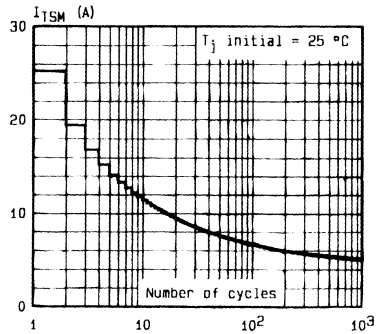

Fig. 6 - Non repetitive surge peak on-state current versus number of cycles.

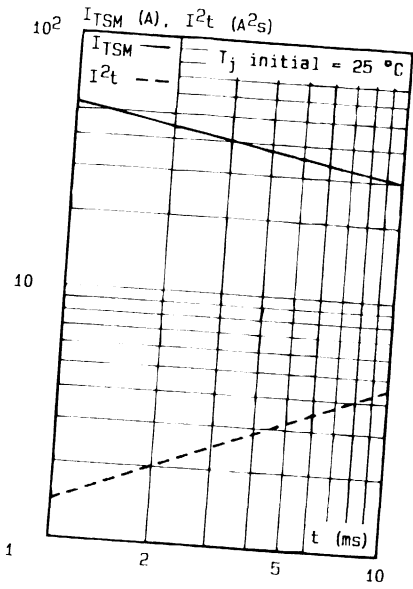

Fig.7 - Non repetitive surge peak on-state current for a sinusoidal pulse with width :  $t \leq 10$  ms. and corresponding value of  $I^2t$ .

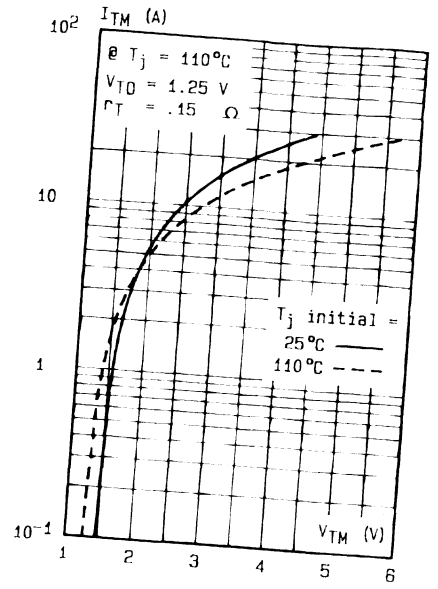

Fig.8 - On-state characteristics (maximum values).





**SENSITIVE GATE TRIACS**

- GLASS PASSIVATED CHIP
- HIGH SURGE CURRENT

**DESCRIPTION**

Low power triacs suited for 50 and 60 Hz up to 380 V<sub>RMS</sub>.

**APPLICATIONS**

- CONTROL SPEED FOR LITTLE MOTORS ;  
ELECTRIC PUMP OR VENTILATOR, SEWING  
MACHINE
- RELAY, DETECTOR, ALARM SYSTEM
- ELECTRONIC STARTER FOR LAMP
- HIGH POWER TRIAC DRIVER

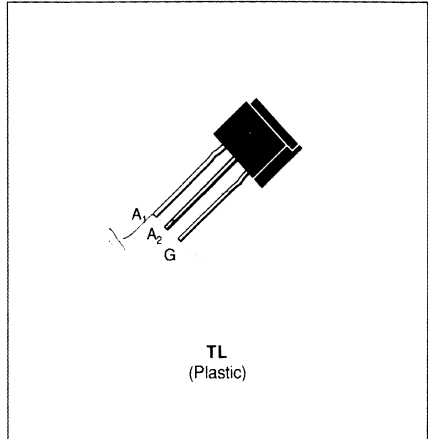

**ABSOLUTE RATINGS** (limiting values)

Symbol	Parameter	Value	Unit
$I_{T(RMS)}$	RMS on-state Current (360° conduction angle)	$T_j = 40\text{ °C}$ 3	A
$I_{T(RMS)}$	RMS on-state Current on Printed Circuit (360° conduction angle)	$T_a = 25\text{ °C}$ 1.3 (3)	A
$I_{TSM}$	Non Repetitive Surge Peak on-state Current ( $T_j$ initial = 25 °C - Half sine wave)	$t = 8.3\text{ ms}$	31.5
		$t = 10\text{ ms}$	30
$I^2t$	$I^2t$ Value for Fusing	$t = 10\text{ ms}$	4.5
$di/dt$	Critical Rate of Rise of on-state Current (1)	Repetitive	10
$T_{stg}$ $T_j$	Storage and Operating Junction Temperature Range		- 40 to 150
			- 40 to 110

Symbol	Parameter	TLC116T	TLC226T	TLC336T	TLC386T	Unit
$V_{DRM}$	Repetitive Peak off-state Voltage (2)	200	400	600	700	V

- (1)  $I_G = 50\text{ mA}$   $di/dt = 1\text{ A}/\mu\text{s}$   
(2)  $T_j = 110\text{ °C}$ .  
(3) With Cu surface = 1 cm<sup>2</sup>.

**THERMAL RESISTANCES**

Symbol	Parameter	Value	Unit
$R_{th(j-a)}$	Junction to Ambient on Printed Circuit	50 (1)	°C/W
$R_{th(j-l)}$	Junction-leads for 360° Conduction Angle (F = 50 Hz)	15	°C/W

- 1) With Cu surface = 1 cm<sup>2</sup>.

**GATE CHARACTERISTICS** (maximum values)

$P_{GM} = 2 \text{ W}$  ( $t_p = 10 \mu\text{s}$ )       $I_{GM} = 1 \text{ A}$  ( $t_p = 10 \mu\text{s}$ )  
 $P_{G(AV)} = 0.1 \text{ W}$        $V_{GM} = 16 \text{ V}$  ( $t_p = 10 \mu\text{s}$ )

**ELECTRICAL CHARACTERISTICS**

Symbol	Test Conditions			Quadrants	Min.	Typ.	Max.	Unit
$I_{GT}$	$T_j = 25 \text{ }^\circ\text{C}$	$V_D = 12 \text{ V}$	$R_L = 33 \text{ } \Omega$	I-II-III-IV			5	mA
$V_{GT}$	$T_j = 25 \text{ }^\circ\text{C}$	$V_D = 12 \text{ V}$	$R_L = 33 \text{ } \Omega$	I-II-III-IV			1.5	V
$V_{GD}$	$T_j = 110 \text{ }^\circ\text{C}$	$V_D = V_{DRM}$	$R_L = 3.3 \text{ k}\Omega$	I-II-III-IV	0.2			V
$I_H^*$	$T_j = 25 \text{ }^\circ\text{C}$	$I_T = 100 \text{ mA}$	Gate Open				15	mA
$I_L$	$T_j = 25 \text{ }^\circ\text{C}$	$V_D = 12 \text{ V}$	$I_G = 10 \text{ mA}$	I-II-III-IV			15	mA
$V_{TM}^*$	$T_j = 25 \text{ }^\circ\text{C}$	$I_{TM} = 4 \text{ A}$	$t_p = 10 \text{ ms}$				1.85	V
$I_{DRM}^*$	$V_{DRM}$ Specified	$T_j = 25 \text{ }^\circ\text{C}$					0.01	mA
		$T_j = 110 \text{ }^\circ\text{C}$					0.75	
$dv/dt^*$	$T_j = 110 \text{ }^\circ\text{C}$	Gate Open				10		V/ $\mu\text{s}$
$(dv/dt)_c^*$	$T_j = 40 \text{ }^\circ\text{C}$	$V_D = V_{DRM}$	$I_T = 4 \text{ A}$			1		V/ $\mu\text{s}$
		$(di/dt)_c = 1.3 \text{ A/ms}$						
$t_{gt}$	$T_j = 25 \text{ }^\circ\text{C}$	$V_D = V_{DRM}$	$I_T = 4 \text{ A}$	I-II-III-IV		3		$\mu\text{s}$
	$I_G = 100 \text{ mA}$	$di_G/dt = 1 \text{ A}/\mu\text{s}$						

\* For either polarity of electrode  $A_2$  voltage with reference to electrode  $A_1$ .

**PACKAGE MECHANICAL DATA**

TL Plastic

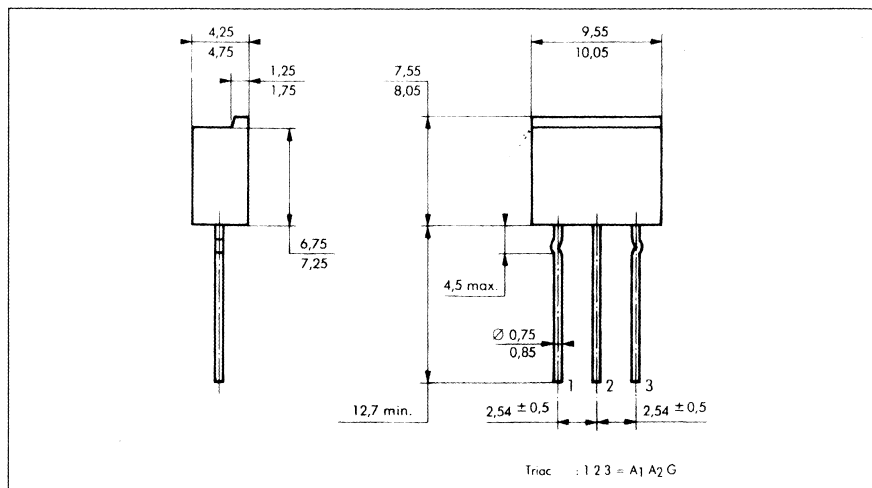

Cooling method : by convection (method A)  
 Marking : type number  
 Weight : 0.8 g.

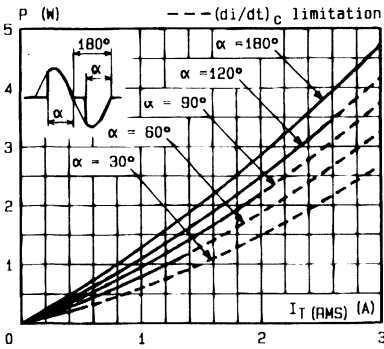

Fig. 1 - Maximum mean power dissipation versus RMS on state current.

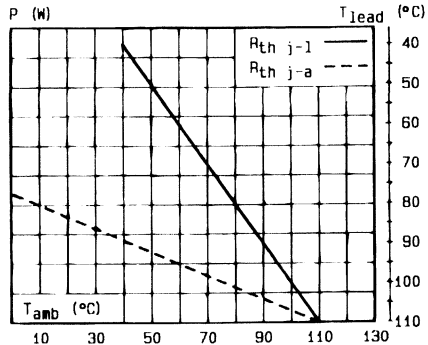

Fig. 2 - Correlation between maximum mean power dissipation and maximum allowable temperatures ( $T_{amb}$  and  $T_{lead}$ ): resistances heatsink + contact.

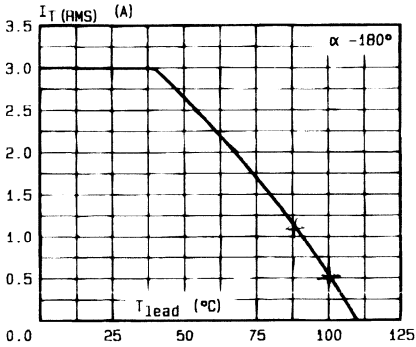

Fig. 3 - RMS on-state current versus lead temperature.

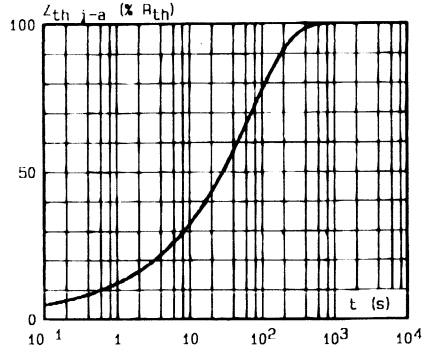

Fig. 4 - Thermal transient impedance junction to ambient versus pulse duration.

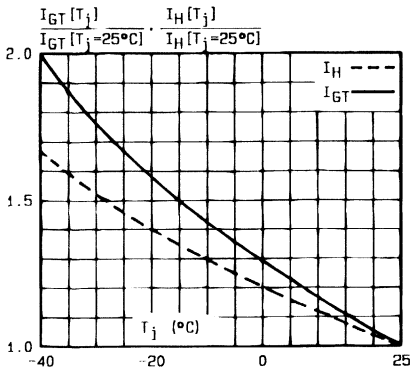

Fig. 5 - Relative variation of gate trigger current and holding current versus junction temperature.

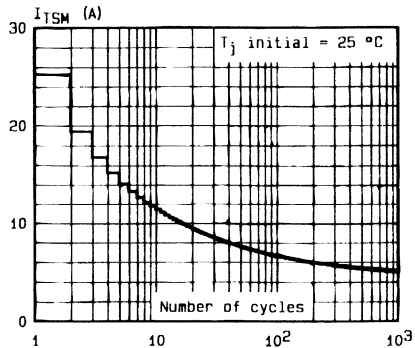

Fig. 6 - Non repetitive surge peak on-state current versus number of cycles.

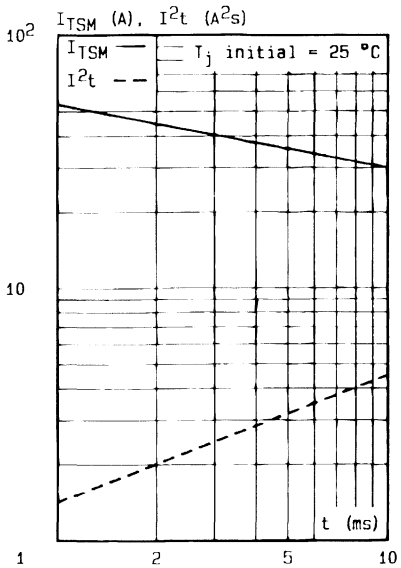

Fig.7 - Non repetitive surge peak on-state current for a sinusoidal pulse with width :  $t \leq 10$  ms, and corresponding value of  $I^2t$ .

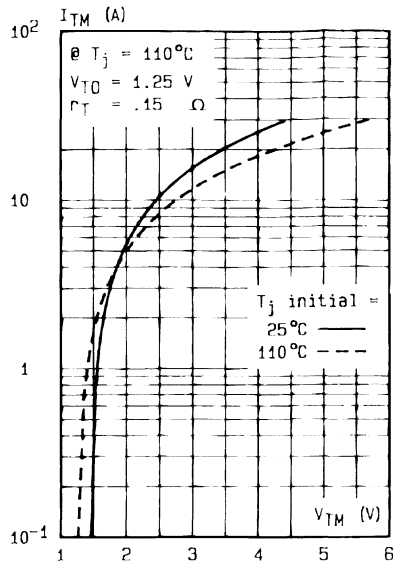

Fig.8 - On-state characteristics (maximum values).

**TRIGGER DIODES**
**DELIVERY**

Antistatic film : 2500 devices per reel.

**APPLICATIONS**

Thyristors and triacs triggering.

**ADVANTAGES**

High reliability glass passivation insuring parameter stability and protection against junction contamination

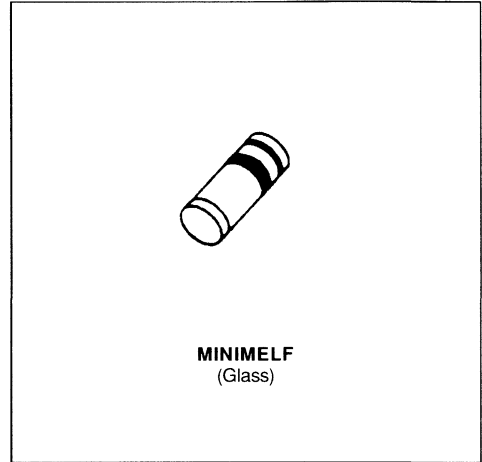
**ABSOLUTE RATINGS** (limiting values)

Symbol	Parameter		Value	Unit
P	Power Dissipation (1)	$T_a = 50\text{ }^\circ\text{C}$	150	mW
$I_{TRM}$	Repetitive Peak on-state Current	$t_p = 20\text{ }\mu\text{s}$ $F = 100\text{ Hz}$	2	A
$T_{stg}$ $T_j$	Storage and Operating Junction Temperature Range		- 40 to 125 - 40 to 110	$^\circ\text{C}$ $^\circ\text{C}$

**THERMAL RESISTANCES**

Symbol	Parameter	Value	Unit
$R_{th(j-a)}$	Junction-ambient (1)	400	$^\circ\text{C/W}$
$R_{th(j-l)}$	Junction Tie-point	300	$^\circ\text{C/W}$

(1) Mounted ceramic substrate of 10 mm x 10 mm x 0.6 mm.

**ELECTRICAL CHARACTERISTICS** ( $T_j = 25\text{ }^\circ\text{C}$ )

Symbol	Parameter	Test Conditions	Types	Min.	Typ.	Max.	Unit
$V_{BO}$	Breakover Voltage*	$C = 22\text{ nF}^{**}$ See diagram 1	TMMDB3	28	32	36	V
$[ +V_{BO}  -  -V_{BO} ]$	Breakover Voltage Symmetry	$C = 22\text{ nF}^{**}$ See diagram 1				$\pm 3$	V
$ \Delta V_{\pm} $	Dynamic Breakback Voltage*	$\Delta I = [I_{BO} \text{ to } I_F = 10\text{ mA}]$ See diagram 1		5			V
$V_O$	Output Voltage*	See diagram 2		5			V
$I_{BO}$	Breakover Current*	$C = 22\text{ nF}^{**}$				100	$\mu\text{A}$
$t_r$	Rise Time*	See diagram 3			1.5		$\mu\text{s}$
$I_B$	Leakage Current*	$V_B = 0.5 V_{BO}$ max See diagram 1				10	$\mu\text{A}$

\* Electrical characteristic applicable in both forward and reverse directions.

\*\* Connected in parallel with the device.

**DIAGRAM 1 :** Current-voltage characteristics.

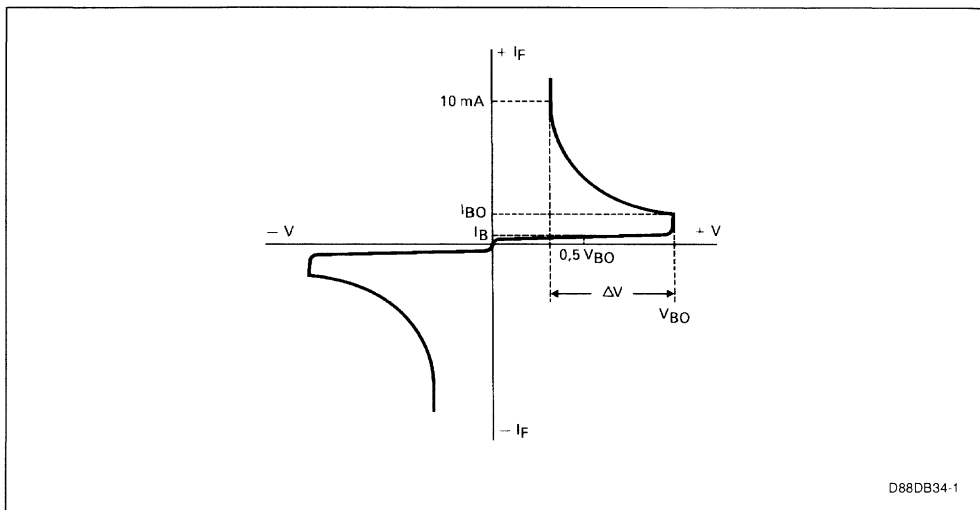

D88DB34-1

**DIAGRAM 2 :** Test circuit for output voltage.

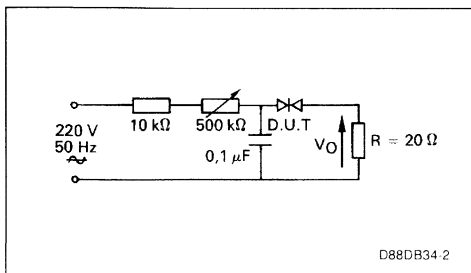

D88DB34-2

**DIAGRAM 3 :** Test circuit see diagram 2.  
Adjust R for  $I_p = 0.5\text{ A}$ .

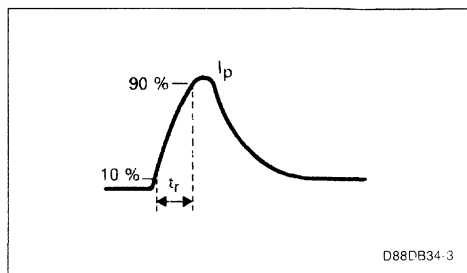

D88DB34-3

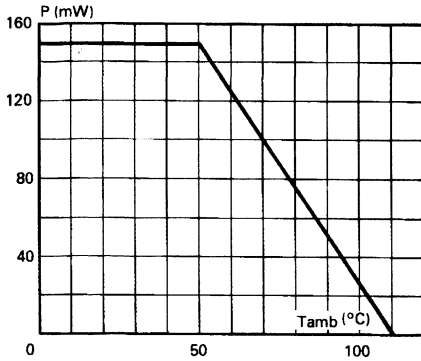

Fig. 1 - Power dissipation versus ambient temperature (maximum values).

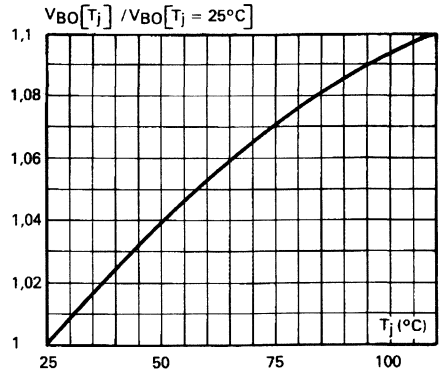

Fig. 2 - Relative variation of VBO versus junction temperature (typical values).

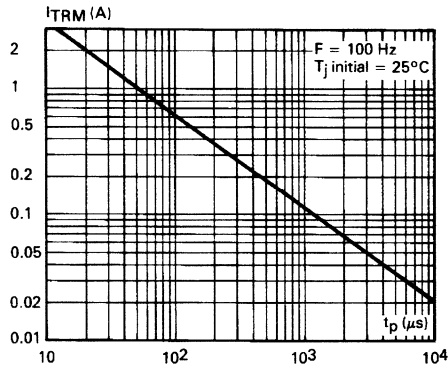
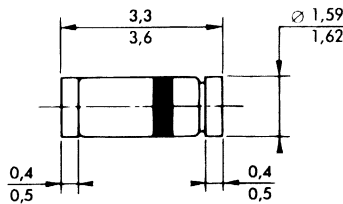

Fig. 3 - Peak pulse current versus pulse duration (maximum values).

**PACKAGE MECHANICAL DATA**

**MINIMELF**







**ALTERNISTORS**

- $(di/dt)_c > 88$  A/ms (400 Hz)
- INSULATING VOLTAGE : 2500 V<sub>RMS</sub>  
( $t \leq 1$  mn - F = 50 Hz)
- UL RECOGNIZED (EB1734)

**APPLICATIONS**

- POWER CONTROL ON INDUCTIVE LOAD  
(motor, transformer...)
- HIGH FREQUENCY OR HIGH  $(di/dt)_c$  LEVEL  
CIRCUITS

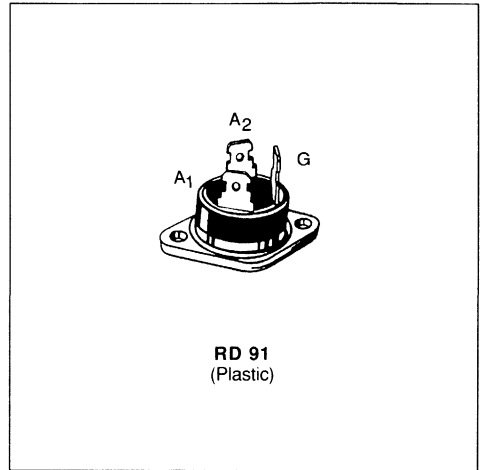
**DESCRIPTION**

New range of solid state AC - switches with very high commutating capability.

**ABSOLUTE RATINGS** (limiting values)

Symbol	Parameter		Value	Unit
$I_{T(RMS)}$	RMS on-state Current (360° conduction angle)		$T_C = 80$ °C 25	A
$I_{TSM}$	Non Repetitive Surge Peak on-state Current		$t = 10$ ms 230	A
			$t = 8.3$ ms 250	
			$t = 2.5$ ms 390	
$I^2t$	$I^2t$ Value for Fusing	$t = 10$ ms	265	A <sup>2</sup> s
$di/dt$	Critical Rate of Rise of on-state Current (1)		100	A/μs
$T_{stg}$ $T_J$	Storage and Operating Junction Temperature Range		- 40 to 125 - 40 to 125	°C °C

Symbol	Parameter	TODV							Unit
		125	225	425	625	825	1025	1225	
$V_{DRM}$	Repetitive Peak off-state Voltage (2)	100	200	400	600	800	1000	1200	V

(1)  $I_G = 1.5$  A  $di_G/dt = 1$  A/μs

(2)  $T_J = 125$  °C.

**THERMAL RESISTANCES**

Symbol	Parameter	Value	Unit
$R_{th(c-h)}$	Contact (case-heatsink) with Grease	0.1	°C/W
$R_{th(j-c)}$ DC	Junction to Case for DC	1.6	°C/W
$R_{th(j-c)}$ AC	Junction to Case for 360° Conduction Angle (F = 50 Hz)	1.2	°C/W

**GATE CHARACTERISTICS** (maximum values)

$P_{GM} = 40 \text{ W}$  ( $t_p = 10 \mu\text{s}$ )

$I_{GM} = 8 \text{ A}$  ( $t_p = 10 \mu\text{s}$ )

$P_{G(AV)} = 1 \text{ W}$

$V_{GM} = 16 \text{ V}$  ( $t_p = 10 \mu\text{s}$ )

**ELECTRICAL CHARACTERISTICS**

Symbol	Test Conditions	Quadrants	Min.	Typ.	Max.	Unit
$I_{GT}$	$T_j = 25 \text{ }^\circ\text{C}$ $V_D = 12 \text{ V}$ $R_L = 33 \text{ } \Omega$ Pulse Duration $> 20 \mu\text{s}$	I-II-III			150	mA
$V_{GT}$	$T_j = 25 \text{ }^\circ\text{C}$ $V_D = 12 \text{ V}$ $R_L = 33 \text{ } \Omega$ Pulse Duration $> 20 \mu\text{s}$	I-II-III			1.5	V
$V_{GD}$	$T_j = 125 \text{ }^\circ\text{C}$ $V_D = V_{DRM}$ $R_L = 3.3 \text{ k}\Omega$	I-II-III	0.2			V
$I_{H^*}$	$T_j = 25 \text{ }^\circ\text{C}$ $I_T = 500 \text{ mA}$ Gate Open			50		mA
$I_L$	$T_j = 25 \text{ }^\circ\text{C}$ $V_D = 12 \text{ V}$ $I_G = 300 \text{ mA}$ Pulse Duration $> 20 \mu\text{s}$	I-III		50		mA
		II		100		
$V_{TM^*}$	$T_j = 25 \text{ }^\circ\text{C}$ $I_{TM} = 35 \text{ A}$ $t_p = 10 \text{ ms}$				1.8	V
$I_{DRM^*}$	$T_j = 125 \text{ }^\circ\text{C}$ $V_{DRM}$ Specified				8	mA
$dv/dt^*$	$T_j = 125 \text{ }^\circ\text{C}$ Gate Open Linear Slope upto $V_D = 67\% V_{DRM}$	$V_{DRM} \leq 800 \text{ V}$		500		V/ $\mu\text{s}$
		$V_{DRM} \geq 1000 \text{ V}$		250		
$(di/dt)_c^*$	$T_C = 80 \text{ }^\circ\text{C}$ $V_D = V_{DRM}$ $I_T = 35 \text{ A}$	$(dv/dt)_c = 200 \text{ V}/\mu\text{s}$		20		A/ms
		$(dv/dt)_c = 10 \text{ V}/\mu\text{s}$		88		
$t_{gt}$	$T_j = 25 \text{ }^\circ\text{C}$ $V_D = V_{DRM}$ $I_T = 35 \text{ A}$ $I_G = 0.5 \text{ A}$ $di_G/dt = 3.5 \text{ A}/\mu\text{s}$	I-II-III		2.5		$\mu\text{s}$

\* For either polarity of electrode  $A_2$  voltage with reference to electrode  $A_1$ .

**PACKAGE MECHANICAL DATA : RD 91 Plastic**

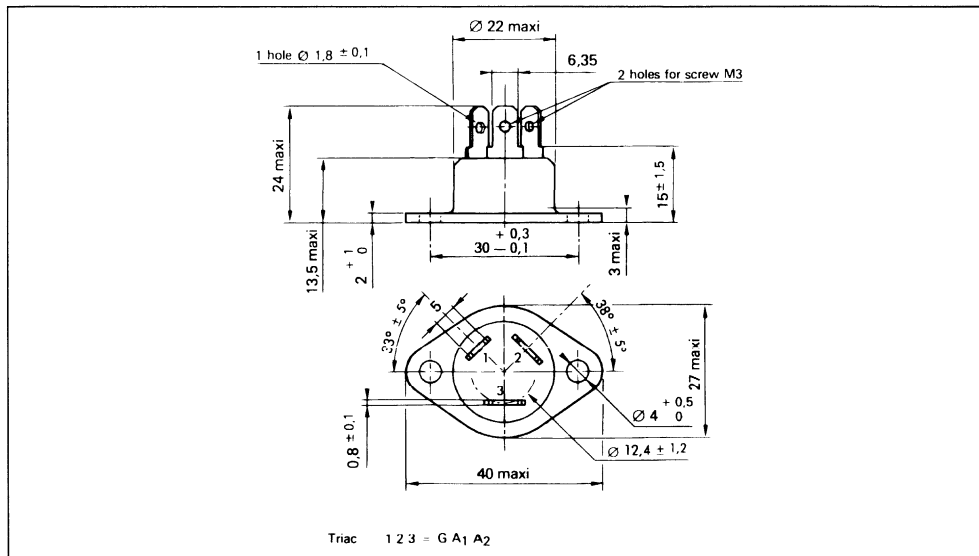

Cooling method : by conduction (method C)

Marking : type number

Weight : 15 g

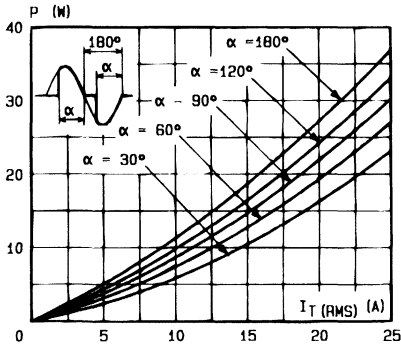

Fig. 1 - Maximum mean power dissipation versus RMS on-state current.

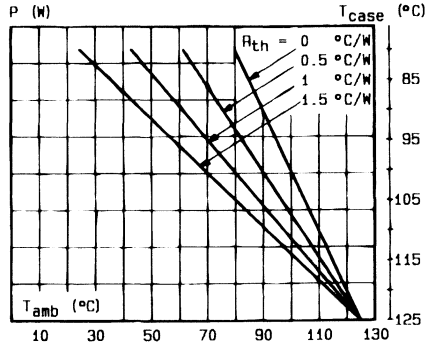

Fig. 2 - Correlation between maximum mean power dissipation and maximum allowable temperatures ( $T_{amb}$  and  $T_{case}$ ) for different thermal resistances heatsink + contact.

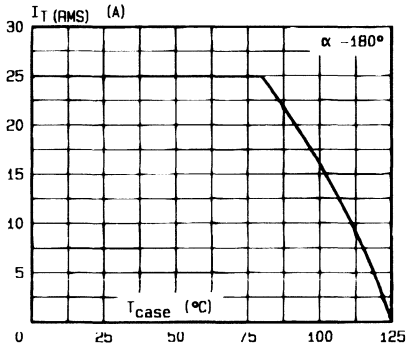

Fig. 3 - RMS on-state current versus case temperature.

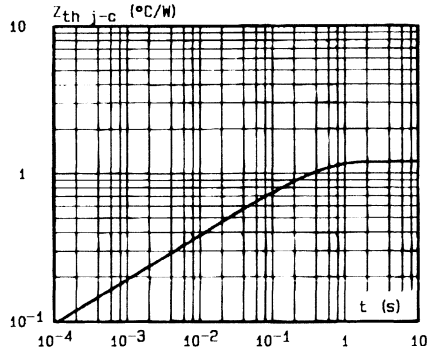

Fig. 4 - Thermal transient impedance junction to case versus pulse duration.

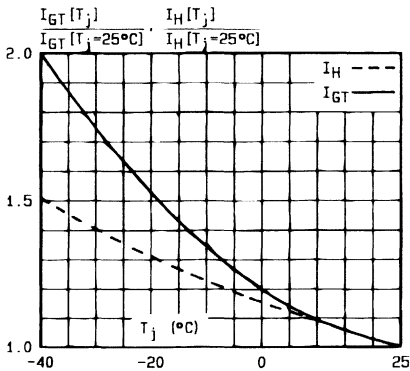

Fig. 5 - Relative variation of gate trigger current and holding current versus junction temperature.

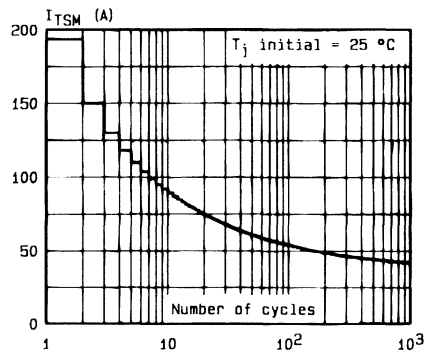

Fig. 6 - Non repetitive surge peak on-state current versus number of cycles.

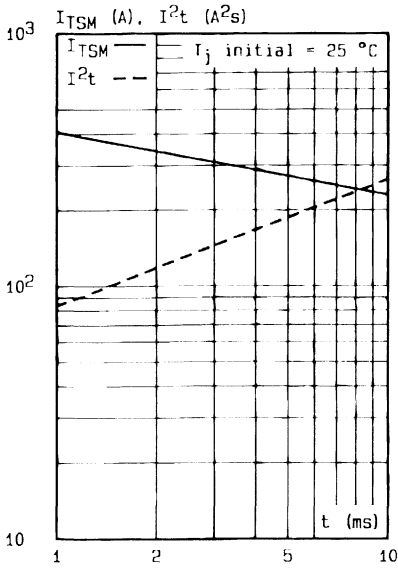

Fig.7 - Non repetitive surge peak on-state current for a sinusoidal pulse with width :  $t \leq 10$  ms, and corresponding value of  $I^2t$ .

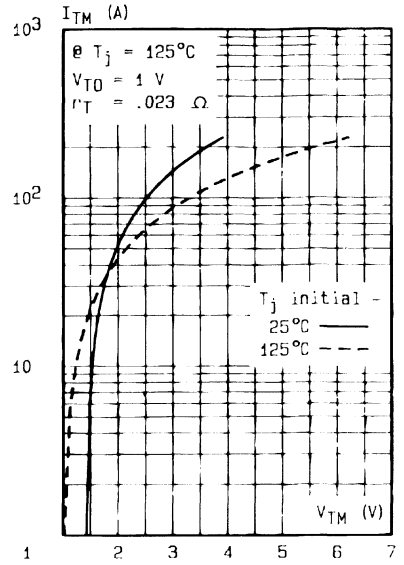

Fig.8 - On-state characteristics (maximum values).

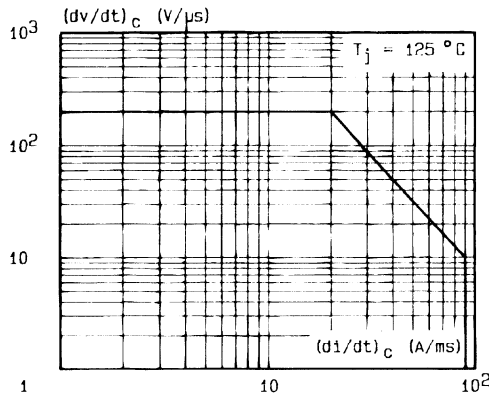

Fig.9 - Safe operating area.

## ALTERNISTORS

- $(di/dt)_c < 142 \text{ A/ms}$  (400 Hz)
- INSULATING VOLTAGE :  $2500 V_{RMS}$   
( $t \leq 1 \text{ mn}$  -  $F = 50 \text{ Hz}$ )
- UL RECOGNIZED (EB1734)

### APPLICATIONS

- POWER CONTROL ON INDUCTIVE LOAD  
(motor, transformer...)
- HIGH FREQUENCY OR HIGH  $(di/dt)_c$  LEVEL  
CIRCUITS

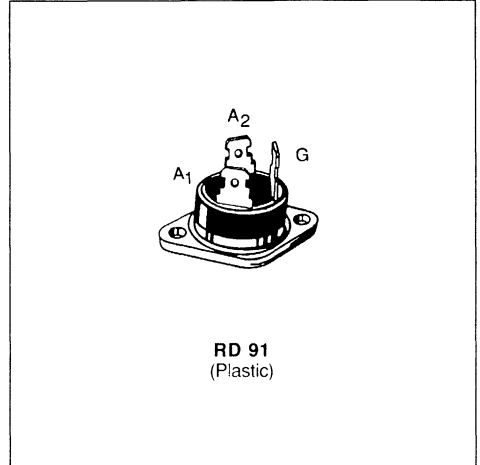

### DESCRIPTION

New range of solid state AC - switches with very high commutating capability.

### ABSOLUTE RATINGS (limiting values)

Symbol	Parameter		Value	Unit
$I_{T(RMS)}$	RMS on-state Current (360° conduction angle)	$T_C = 75 \text{ }^\circ\text{C}$	40	A
$I_{TSM}$	Non Repetitive Surge Peak on-state Current	$t = 10 \text{ ms}$	350	A
		$t = 8.3 \text{ ms}$	370	
		$t = 2.5 \text{ ms}$	590	
$I^2t$	$I^2t$ Value for Fusing	$t = 10 \text{ ms}$	610	$\text{A}^2\text{s}$
$di/dt$	Critical Rate of Rise of on-state Current (1)		100	$\text{A}/\mu\text{s}$
$T_{stg}$ $T_j$	Storage and Operating Junction Temperature Range		- 40 to 125 - 40 to 125	$^\circ\text{C}$ $^\circ\text{C}$

Symbol	Parameter	TODV							Unit
		140	240	440	640	840	1040	1240	
$V_{DRM}$	Repetitive Peak off-state Voltage (2)	100	200	400	600	800	1000	1200	V

(1)  $I_G = 1.5 \text{ A}$   $di_G/dt = 1 \text{ A}/\mu\text{s}$

(2)  $T_j = 125 \text{ }^\circ\text{C}$ .

### THERMAL RESISTANCES

Symbol	Parameter	Value	Unit
$R_{th(c-h)}$	Contact (case-heatsink) with Grease	0.1	$^\circ\text{C}/\text{W}$
$R_{th(j-c)} \text{ DC}$	Junction to Case for DC	1.2	$^\circ\text{C}/\text{W}$
$R_{th(j-c)} \text{ AC}$	Junction to Case for 360° Conduction Angle ( $F = 50 \text{ Hz}$ )	0.9	$^\circ\text{C}/\text{W}$

**GATE CHARACTERISTICS** (maximum values)

$P_{GM} = 40 \text{ W}$  ( $t_p = 10 \mu\text{s}$ )       $I_{GM} = 8 \text{ A}$  ( $t_p = 10 \mu\text{s}$ )  
 $P_{G(AV)} = 1 \text{ W}$        $V_{GM} = 16 \text{ V}$  ( $t_p = 10 \mu\text{s}$ )

**ELECTRICAL CHARACTERISTICS**

Symbol	Test Conditions		Quadrants	Min.	Typ.	Max.	Unit
$I_{GT}$	$T_j = 25 \text{ }^\circ\text{C}$ Pulse Duration > 20 $\mu\text{s}$	$V_D = 12 \text{ V}$ $R_L = 33 \text{ } \Omega$	I-II-III			200	mA
$V_{GT}$	$T_j = 25 \text{ }^\circ\text{C}$ Pulse Duration > 20 $\mu\text{s}$	$V_D = 12 \text{ V}$ $R_L = 33 \text{ } \Omega$	I-II-III			1.5	V
$V_{GD}$	$T_j = 125 \text{ }^\circ\text{C}$	$V_D = V_{DRM}$ $R_L = 3.3 \text{ k}\Omega$	I-II-III	0.2			V
$I_H^*$	$T_j = 25 \text{ }^\circ\text{C}$	$I_T = 500 \text{ mA}$ Gate Open			50		mA
$I_L$	$T_j = 25 \text{ }^\circ\text{C}$ Pulse Duration > 20 $\mu\text{s}$	$V_D = 12 \text{ V}$ $I_G = 400 \text{ mA}$	I-III		50		mA
			II		100		
$V_{TM}^*$	$T_j = 25 \text{ }^\circ\text{C}$	$I_{TM} = 60 \text{ A}$ $t_p = 10 \text{ ms}$				1.8	V
$I_{DRM}^*$	$T_j = 125 \text{ }^\circ\text{C}$	$V_{DRM}$ Specified				8	mA
$dv/dt^*$	$T_j = 125 \text{ }^\circ\text{C}$ Linear Slope up to $V_D = 67\% V_{DRM}$	Gate Open	$V_{DRM} \leq 800 \text{ V}$	500			V/ $\mu\text{s}$
			$V_{DRM} \geq 1000 \text{ V}$	250			
$(di/dt)_c^*$	$T_C = 75 \text{ }^\circ\text{C}$ $I_T = 60 \text{ A}$	$V_D = V_{DRM}$	$(dv/dt)_c = 200 \text{ V}/\mu\text{s}$	35			A/ms
			$(dv/dt)_c = 10 \text{ V}/\mu\text{s}$	142			
$t_{gt}$	$T_j = 25 \text{ }^\circ\text{C}$ $I_G = 0.5 \text{ A}$	$V_D = V_{DRM}$ $I_T = 60 \text{ A}$ $di_G/dt = 3.5 \text{ A}/\mu\text{s}$	I-II-III		2.5		$\mu\text{s}$

\* For either polarity of electrode  $A_2$  voltage with reference to electrode  $A_1$ .

**PACKAGE MECHANICAL DATA : RD 91 Plastic**

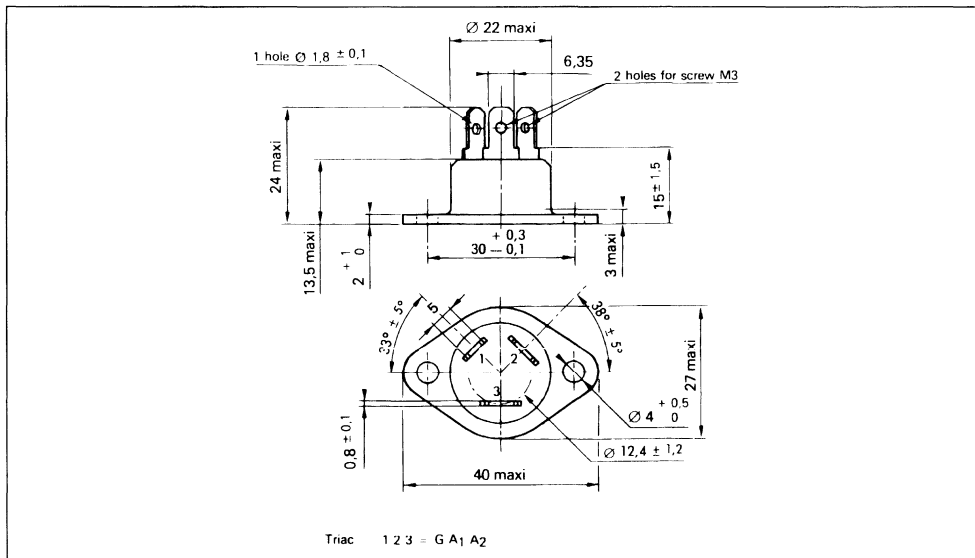

Cooling method : by conduction (method C)  
 Marking : type number  
 Weight : 15 g

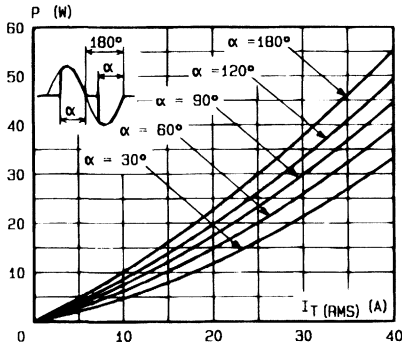

Fig. 1 - Maximum mean power dissipation versus RMS on-state current.

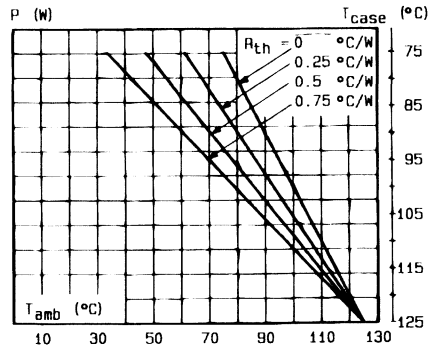

Fig. 2 - Correlation between maximum mean power dissipation and maximum allowable temperatures ( $T_{amb}$  and  $T_{case}$ ) for different thermal resistances heatsink + contact.

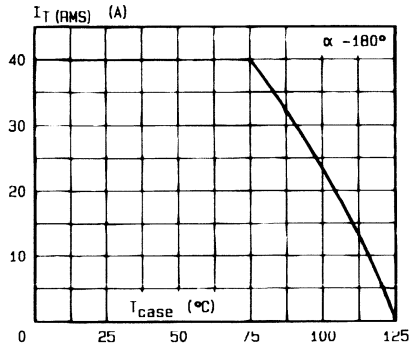

Fig. 3 - RMS on-state current versus case temperature.

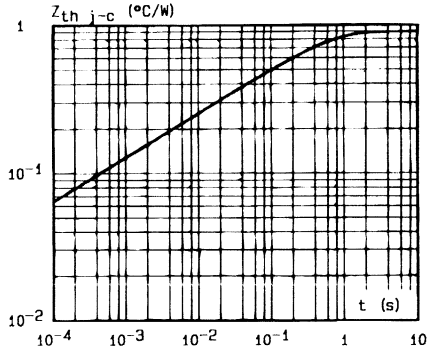

Fig. 4 - Thermal transient impedance junction to case versus pulse duration.

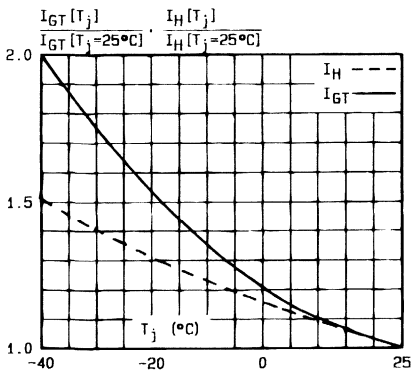

Fig. 5 - Relative variation of gate trigger current and holding current versus junction temperature.

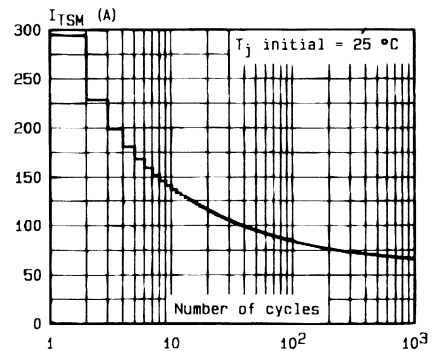

Fig. 6 - Non repetitive surge peak on-state current versus number of cycles.

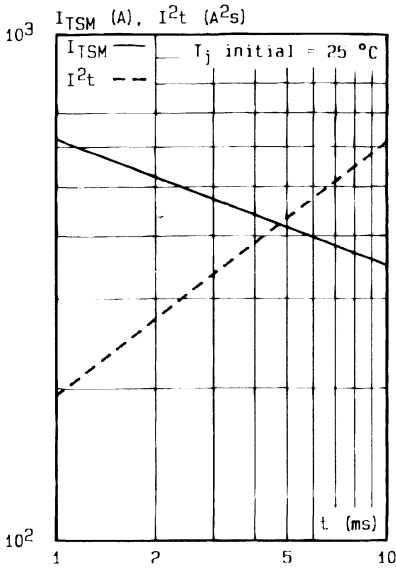

Fig. 7 - Non repetitive surge peak on-state current for a sinusoidal pulse with width :  $t \leq 10$  ms, and corresponding value of  $I^2t$ .

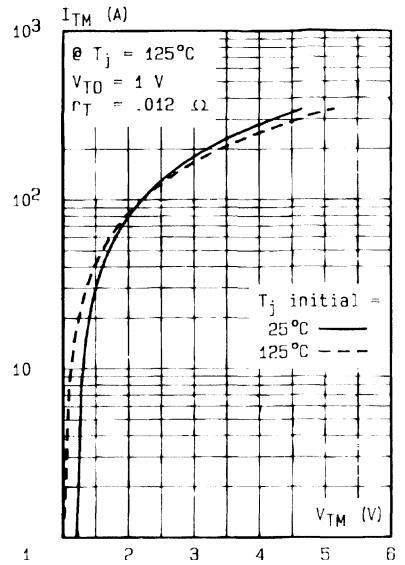

Fig. 8 - On-state characteristics (maximum values).

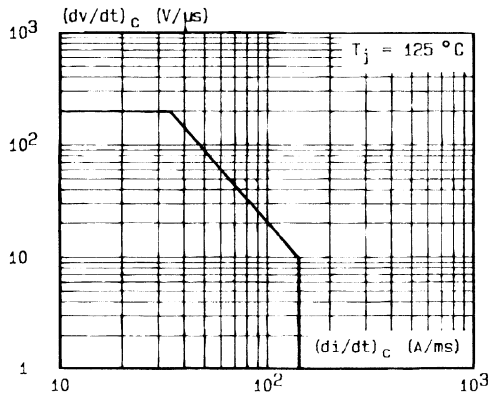

Fig. 9 - Safe operating area.



**ALTERNISTORS**

- $(di/dt)_c > 88 \text{ A/ms}$  (400 Hz)
- INSULATING VOLTAGE : 2500  $V_{RMS}$   
( $t \leq 1 \text{ mn}$  -  $F = 50 \text{ Hz}$ )
- UL RECOGNIZED (EB81734)

**APPLICATIONS**

- POWER CONTROL ON INDUCTIVE LOAD  
(motor, transformer...)
- HIGH FREQUENCY OR HIGH  $(di/dt)_c$  LEVEL  
CIRCUITS

**DESCRIPTION**

New range of solid state AC - switches with very high commutating capability.

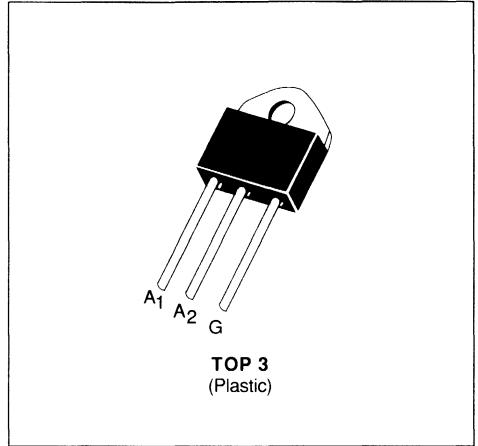
**ABSOLUTE RATINGS** (limiting values)

Symbol	Parameter		Value	Unit
$I_{T(RMS)}$	RMS on-state Current (360° conduction angle)	$T_C = 75 \text{ }^\circ\text{C}$	25	A
$I_{TSM}$	Non Repetitive Surge Peak on-state Current	$t = 10 \text{ ms}$	230	A
		$t = 8.3 \text{ ms}$	250	
		$t = 2.5 \text{ ms}$	390	
$I^2t$	$I^2t$ Value for Fusing	$t = 10 \text{ ms}$	265	$\text{A}^2\text{s}$
$di/dt$	Critical Rate of Rise of on-state Current (1)		100	$\text{A}/\mu\text{s}$
$T_{stg}$ $T_j$	Storage and Operating Junction Temperature Range		- 40 to 125	$^\circ\text{C}$
			- 40 to 125	$^\circ\text{C}$

Symbol	Parameter	TPDV							Unit
		125	225	425	625	825	1025	1225	
$V_{DRM}$	Repetitive Peak off-state Voltage (2)	100	200	400	600	800	1000	1200	V

(1)  $I_G = 1.5 \text{ A}$   $di/dt = 1 \text{ A}/\mu\text{s}$

(2)  $T_j = 125 \text{ }^\circ\text{C}$ .

**THERMAL RESISTANCES**

Symbol	Parameter	Value	Unit
$R_{th(j-a)}$	Junction to Ambient	50	$^\circ\text{C}/\text{W}$
$R_{th(c-h)}$	Contact (case-heatsink) with Grease	0.15	$^\circ\text{C}/\text{W}$
$R_{th(j-c)} \text{ DC}$	Junction to Case for DC	2.09	$^\circ\text{C}/\text{W}$
$R_{th(j-c)} \text{ AC}$	Junction to Case for 360° Conduction Angle ( $F = 50 \text{ Hz}$ )	1.56	$^\circ\text{C}/\text{W}$

**GATE CHARACTERISTICS** (maximum values)

$P_{GM} = 40 \text{ W}$  ( $t_p = 10 \mu\text{s}$ )       $I_{GM} = 8 \text{ A}$  ( $t_p = 10 \mu\text{s}$ )  
 $P_{G(AV)} = 1 \text{ W}$        $V_{GM} = 16 \text{ V}$  ( $t_p = 10 \mu\text{s}$ )

**ELECTRICAL CHARACTERISTICS**

Symbol	Test Conditions	Quadrants	Min.	Typ.	Max.	Unit
$I_{GT}$	$T_j = 25 \text{ }^\circ\text{C}$ $V_D = 12 \text{ V}$ $R_L = 33 \text{ } \Omega$ Pulse Duration > 20 $\mu\text{s}$	I-II-III			150	mA
$V_{GT}$	$T_j = 25 \text{ }^\circ\text{C}$ $V_D = 12 \text{ V}$ $R_L = 33 \text{ } \Omega$ Pulse Duration > 20 $\mu\text{s}$	I-II-III			1.5	V
$V_{GD}$	$T_j = 125 \text{ }^\circ\text{C}$ $V_D = V_{DRM}$ $R_L = 3.3 \text{ k}\Omega$	I-II-III	0.2			V
$I_H^*$	$T_j = 25 \text{ }^\circ\text{C}$ $I_T = 500 \text{ mA}$ Gate Open			50		mA
$I_L$	$T_j = 25 \text{ }^\circ\text{C}$ $V_D = 12 \text{ V}$ $I_G = 300 \text{ mA}$ Pulse Duration > 20 $\mu\text{s}$	I-III		50		mA
		II		100		
$V_{TM}^*$	$T_j = 25 \text{ }^\circ\text{C}$ $I_{TM} = 35 \text{ A}$ $t_p = 10 \text{ ms}$				1.8	V
$I_{DRM}^*$	$T_j = 125 \text{ }^\circ\text{C}$ $V_{DRM}$ Specified				8	mA
$dv/dt^*$	$T_j = 125 \text{ }^\circ\text{C}$ Gate Open Linear Slope upto $V_D = 67\% V_{DRM}$	$V_{DRM} \leq 800 \text{ V}$		500		$V/\mu\text{s}$
		$V_{DRM} \geq 1000 \text{ V}$		250		
$(di/dt)_c^*$	$T_C = 75 \text{ }^\circ\text{C}$ $V_D = V_{DRM}$ $I_T = 35 \text{ A}$	$(dv/dt)_c = 200 \text{ V}/\mu\text{s}$		20		A/ms
		$(dv/dt)_c = 10 \text{ V}/\mu\text{s}$		88		
$t_{gt}$	$T_j = 25 \text{ }^\circ\text{C}$ $V_D = V_{DRM}$ $I_T = 35 \text{ A}$ $I_G = 0.5 \text{ A}$ $di_G/dt = 3.5 \text{ A}/\mu\text{s}$	I-II-III		2.5		$\mu\text{s}$

\* For either polarity of electrode A<sub>2</sub> voltage with reference to electrode A<sub>1</sub>.

**PACKAGE MECHANICAL DATA : TOP 3 Plastic**

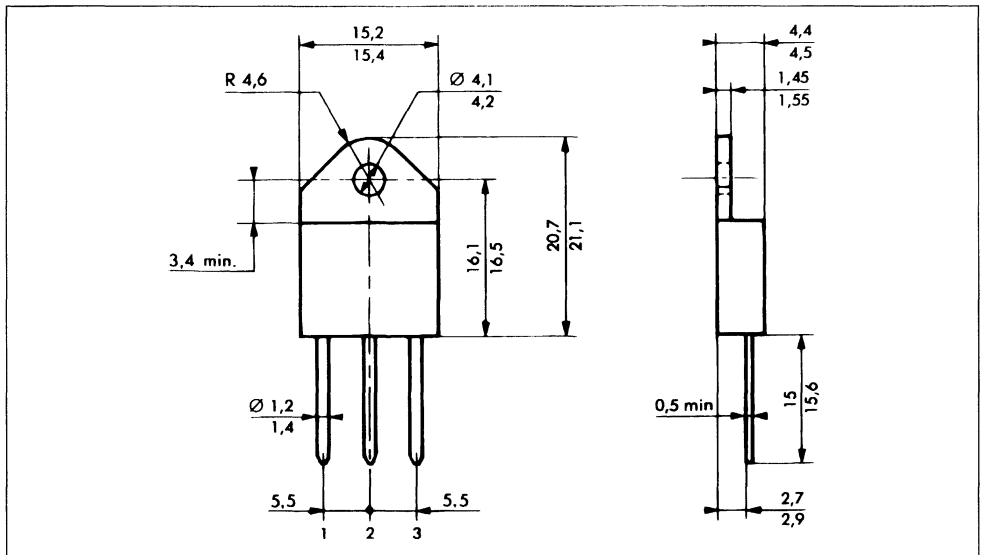

Cooling method : by conduction (method C)  
 Marking : type number  
 Weight : 5 g

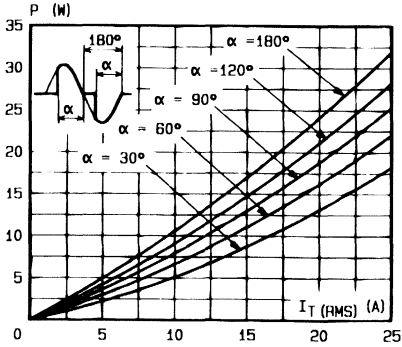

Fig.1 - Maximum mean power dissipation versus RMS on-state current.

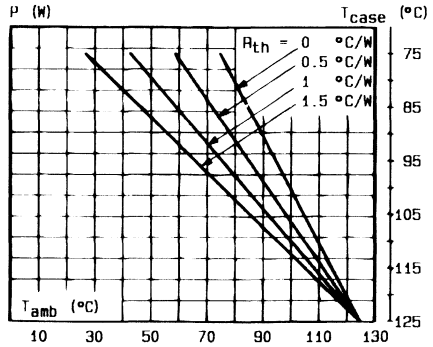

Fig.2 - Correlation between maximum mean power dissipation and maximum allowable temperatures ( $T_{amb}$  and  $T_{case}$ ) for different thermal resistances heatsink + contact.

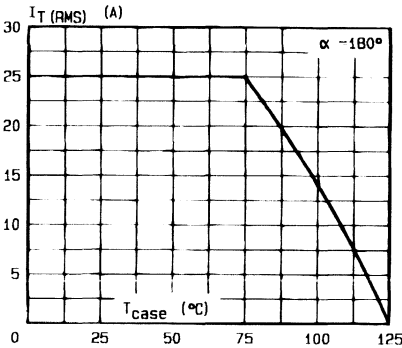

Fig.3 - RMS on-state current versus case temperature.

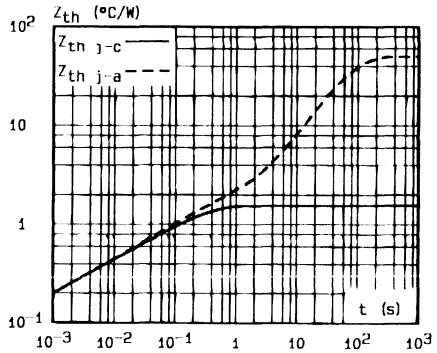

Fig.4 - Thermal transient impedance junction to case and junction to ambient versus pulse duration.

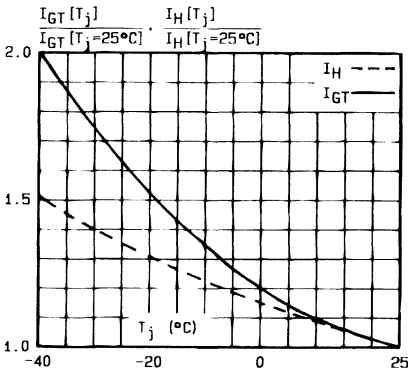

Fig.5 - Relative variation of gate trigger current and holding current versus junction temperature.

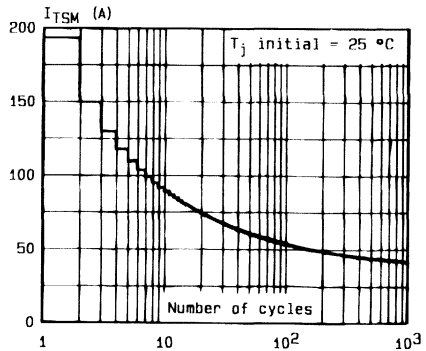

Fig.6 - Non repetitive surge peak on-state current versus number of cycles.

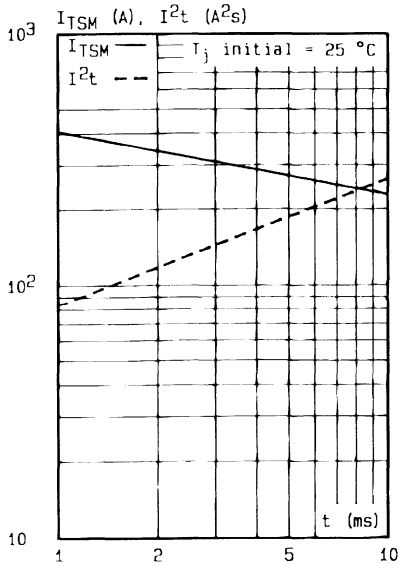

Fig.7 - Non repetitive surge peak on-state current for a sinusoidal pulse with width :  $t \leq 10$  ms, and corresponding value of  $I^2t$ .

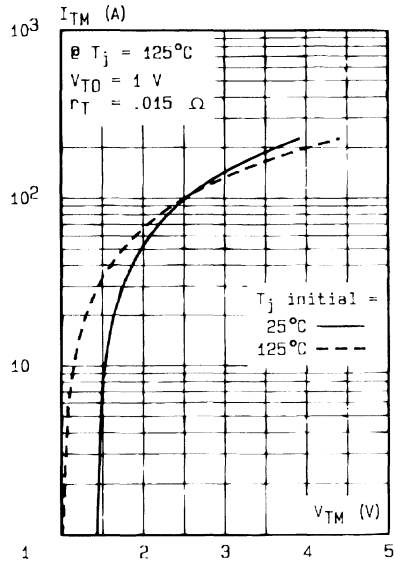

Fig.8 - Un-state characteristics (maximum values).

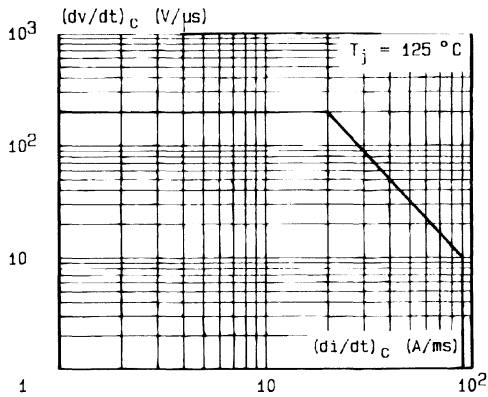

Fig.9 - Safe operating area.

**ALTERNISTORS**

- $(di/dt)_c > 142$  A/ms (400 Hz)
- INSULATING VOLTAGE : 2500 V<sub>RMS</sub>  
( $t \leq 1$  mn - F = 50 Hz)
- UL RECOGNIZED (E81734)

**APPLICATIONS**

- POWER CONTROL ON INDUCTIVE LOAD  
(motor, transformer...)
- HIGH FREQUENCY OR HIGH  $(di/dt)_c$  LEVEL  
CIRCUITS

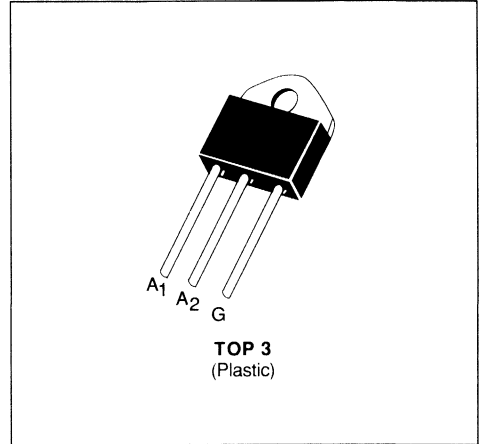
**DESCRIPTION**

New range of solid state AC - switches with very high commutating capability.

**ABSOLUTE RATINGS** (limiting values)

Symbol	Parameter		Value	Unit
$I_{T(RMS)}$	RMS on-state Current (360° conduction angle)	$T_C = 75$ °C	40	A
$I_{TSM}$	Non Repetitive Surge Peak on-state Current	$t = 10$ ms	350	A
		$t = 8.3$ ms	370	
		$t = 2.5$ ms	590	
$I^2t$	$I^2t$ Value for Fusing	$t = 10$ ms	610	A <sup>2</sup> s
$di/dt$	Critical Rate of Rise of on-state Current (1)		100	A/ $\mu$ s
$T_{stg}$ $T_J$	Storage and Operating Junction Temperature Range		- 40 to 125	°C
			- 40 to 125	°C

Symbol	Parameter	TPDV							Unit
		140	240	440	640	840	1040	1240	
$V_{DRM}$	Repetitive Peak off-state Voltage (2)	100	200	400	600	800	1000	1200	V

(1)  $I_G = 1.5$  A  $di_G/dt = 1$  A/ $\mu$ s

(2)  $T_J = 125$  °C.

**THERMAL RESISTANCES**

Symbol	Parameter	Value	Unit
$R_{th(j-a)}$	Junction to Ambient	50	°C/W
$R_{th(c-h)}$	Contact (case-heatsink) with Grease	0.15	°C/W
$R_{th(j-c)}$ DC	Junction to Case for DC	1.2	°C/W
$R_{th(j-c)}$ AC	Junction to Case for 360° Conduction Angle (F = 50 Hz)	0.9	°C/W

**GATE CHARACTERISTICS** (maximum values)

$P_{GM} = 40 \text{ W}$  ( $t_p = 10 \mu\text{s}$ )

$I_{GM} = 8 \text{ A}$  ( $t_p = 10 \mu\text{s}$ )

$P_{G(AV)} = 1 \text{ W}$

$V_{GM} = 16 \text{ V}$  ( $t_p = 10 \mu\text{s}$ )

**ELECTRICAL CHARACTERISTICS**

Symbol	Test Conditions			Quadrants	Min.	Typ.	Max.	Unit
$I_{GT}$	$T_j = 25 \text{ }^\circ\text{C}$ Pulse Duration $> 20 \mu\text{s}$	$V_D = 12 \text{ V}$	$R_L = 33 \Omega$	I-II-III			200	mA
$V_{GT}$	$T_j = 25 \text{ }^\circ\text{C}$ Pulse Duration $> 20 \mu\text{s}$	$V_D = 12 \text{ V}$	$R_L = 33 \Omega$	I-II-III			1.5	V
$V_{GD}$	$T_j = 125 \text{ }^\circ\text{C}$	$V_D = V_{DRM}$	$R_L = 3.3 \text{ k}\Omega$	I-II-III	0.2			V
$I_{H^*}$	$T_j = 25 \text{ }^\circ\text{C}$	$I_T = 500 \text{ mA}$	Gate Open			50		mA
$I_L$	$T_j = 25 \text{ }^\circ\text{C}$ Pulse Duration $> 20 \mu\text{s}$	$V_D = 12 \text{ V}$	$I_G = 400 \text{ mA}$	I-III		50		mA
				II		100		
$V_{TM^*}$	$T_j = 25 \text{ }^\circ\text{C}$	$I_{TM} = 60 \text{ A}$	$t_p = 10 \text{ ms}$				1.8	V
$I_{DRM^*}$	$T_j = 125 \text{ }^\circ\text{C}$	$V_{DRM}$ Specified					8	mA
$dv/dt^*$	$T_j = 125 \text{ }^\circ\text{C}$ Linear Slope upto $V_D = 67\% V_{DRM}$	Gate Open	$V_{DRM} \leq 800 \text{ V}$		500			V/ $\mu\text{s}$
			$V_{DRM} \geq 1000 \text{ V}$		250			
$(di/dt)_c^*$	$T_C = 75 \text{ }^\circ\text{C}$ $I_T = 60 \text{ A}$	$V_D = V_{DRM}$	$(dv/dt)_c = 200 \text{ V}/\mu\text{s}$		35			A/ms
			$(dv/dt)_c = 10 \text{ V}/\mu\text{s}$		142			
$t_{gt}$	$T_j = 25 \text{ }^\circ\text{C}$ $I_G = 0.5 \text{ A}$	$V_D = V_{DRM}$	$I_T = 60 \text{ A}$ $di_G/dt = 3.5 \text{ A}/\mu\text{s}$	I-II-III		2.5		$\mu\text{s}$

\* For either polarity of electrode  $A_2$  voltage with reference to electrode  $A_1$ .

**PACKAGE MECHANICAL DATA : TOP 3 Plastic**

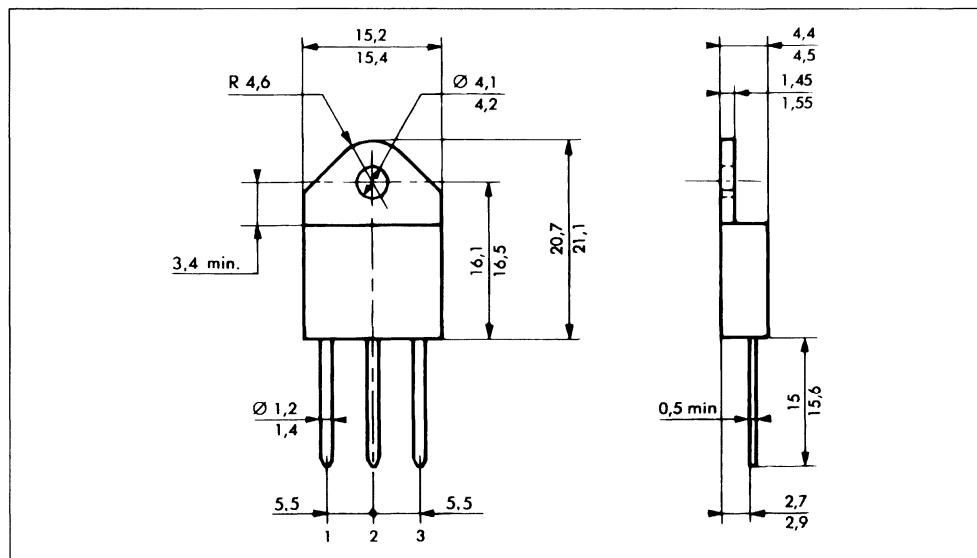

Cooling method : by conduction (method C)  
 Marking : type number  
 Weight : 5 g

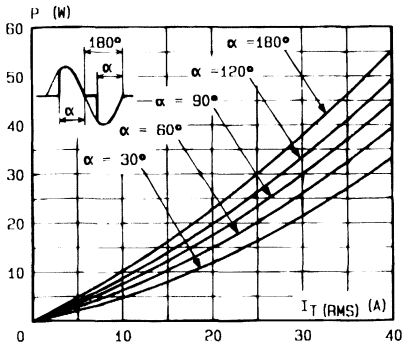

Fig. 1 - Maximum mean power dissipation versus RMS on-state current.

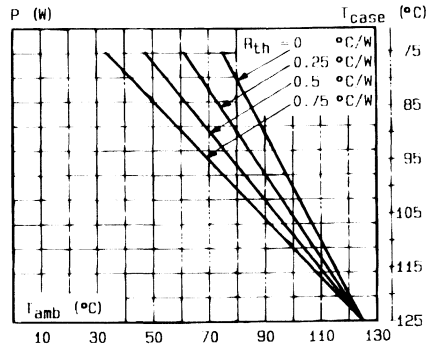

Fig. 2 - Correlation between maximum mean power dissipation and maximum allowable temperatures ( $T_{amb}$  and  $T_{case}$ ) for different thermal resistances heatsink + contact.

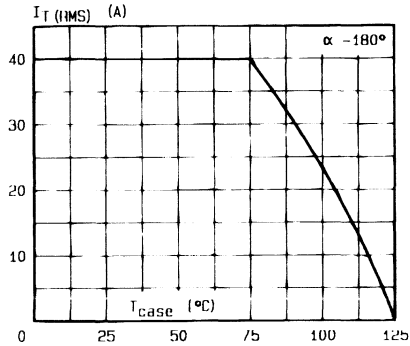

Fig. 3 - RMS on-state current versus case temperature.

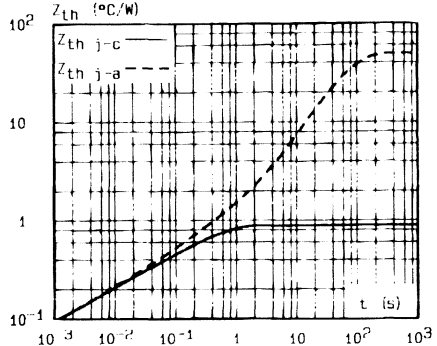

Fig. 4 - Thermal transient impedance junction to case and junction to ambient versus pulse duration.

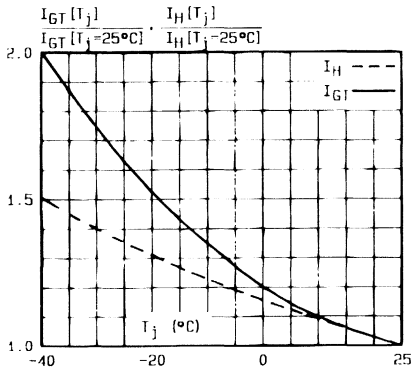

Fig. 5 - Relative variation of gate trigger current and holding current versus junction temperature.

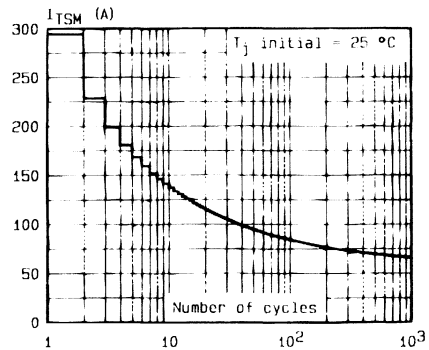

Fig 6 - Non repetitive surge peak on state current versus number of cycles.

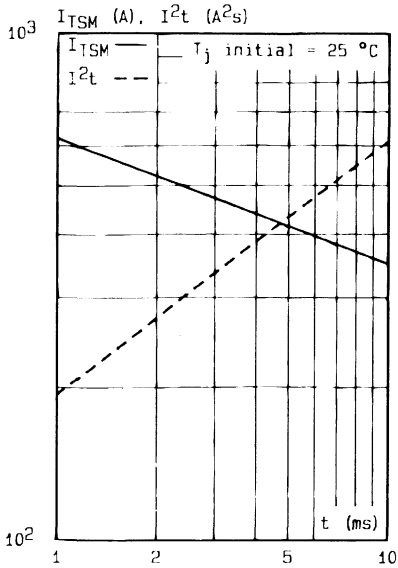

Fig.7 - Non repetitive surge peak on-state current for a sinusoidal pulse with width :  $t \leq 10$  ms, and corresponding value of  $I^2t$ .

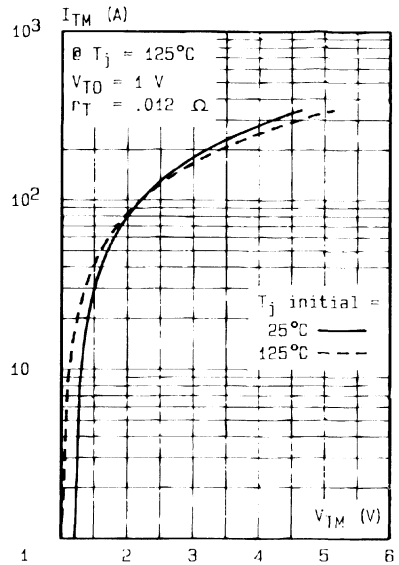

Fig.8 - On-state characteristics (maximum values).

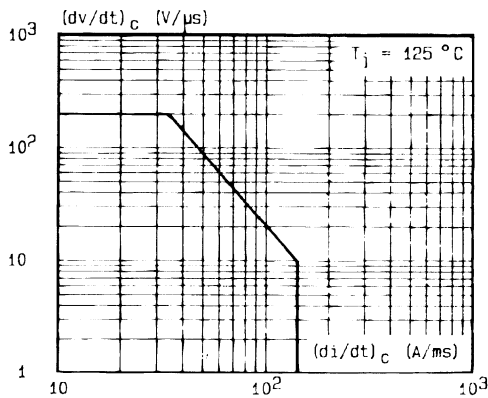

Fig.9 - Safe operating area.





**TRIACS**

- GLASS PASSIVATED CHIP
- I<sub>GT</sub> SPECIFIED IN FOUR QUADRANTS

Thread : 1/4" -28 UNF : type N°  
M6 on request : type N° + suffix M

**ADVANTAGES**

- EXCELLENT (dv/dt)<sub>c</sub> : > 10 V/μs
- METALLIC ENCAPSULATION GIVES AN EXCELLENT THERMAL IMPEDANCE AND HIGH RELIABILITY CONSTRUCTION

**APPLICATIONS**

- MOTOR CONTROL
- HEATING CONTROL
- LIGHT DIMMER

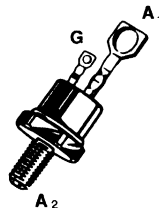

**TO 48**  
(Metal)

**DESCRIPTION**

Power triacs suited for use on 220 V and 380 V main.

**ABSOLUTE RATINGS** (limiting values)

Symbol	Parameter	Value	Unit
I <sub>T(RMS)</sub>	RMS on-state Current (360° conduction angle) T <sub>C</sub> = 60 °C	25	A
I <sub>TSM</sub>	Non Repetitive Surge Peak on-state Current (T <sub>j</sub> initial = 25 °C - Half sine wave)	t = 8.3 ms	262
		t = 10 ms	250
I <sup>2</sup> t	I <sup>2</sup> t Value for Fusing t = 10 ms	312.5	A <sup>2</sup> s
di/dt	Critical Rate of Rise of on-state Current (1)	Repetitive F = 50 Hz	20
		Non Repetitive	100
T <sub>stg</sub> T <sub>j</sub>	Storage and Operating Junction Temperature Range	- 40 to 150 - 40 to 100	°C °C

Symbol	Parameter	TRAL				Unit
		1125D	2225D	3325D	3825D	
V <sub>DRM</sub>	Repetitive Peak off-state Voltage (2)	200	400	600	700	V

(1) I<sub>G</sub> = 1.5 A di/dt = 1 A/μs

(2) T<sub>j</sub> = 100 °C.

**THERMAL RESISTANCES**

Symbol	Parameter	Value	Unit
R <sub>th (c-h)</sub>	Contact (case-heatsink) for Recommended Stud Torque	0.4	°C/W
R <sub>th (j-c) DC</sub>	Junction to Case for DC	1.24	°C/W
R <sub>th (j-c) AC</sub>	Junction to Case for 360 ° Conduction Angle (F = 50 Hz)	0.93	°C/W

**GATE CHARACTERISTICS** (maximum values)

$P_{GM} = 40 \text{ W}$  ( $t_p = 10 \mu\text{s}$ )       $I_{GM} = 6 \text{ A}$  ( $t_p = 10 \mu\text{s}$ )  
 $P_{G(AV)} = 1 \text{ W}$        $V_{GM} = 16 \text{ V}$  ( $t_p = 10 \mu\text{s}$ )

**ELECTRICAL CHARACTERISTICS**

Symbol	Test Conditions	Quadrants	Min.	Typ.	Max.	Unit
$I_{GT}$	$T_j = 25 \text{ }^\circ\text{C}$ $V_D = 12 \text{ V}$ $R_L = 33 \text{ } \Omega$ Pulse Duration > 20 $\mu\text{s}$	I-II-III			100	mA
		IV			150	
$V_{GT}$	$T_j = 25 \text{ }^\circ\text{C}$ $V_D = 12 \text{ V}$ $R_L = 33 \text{ } \Omega$ Pulse Duration > 20 $\mu\text{s}$	I-II-III-IV			1.5	V
$V_{GD}$	$T_j = 100 \text{ }^\circ\text{C}$ $V_D = V_{DRM}$ $R_L = 3.3 \text{ k}\Omega$	I-II-III-IV	0.2			V
$I_{H^*}$	$T_j = 25 \text{ }^\circ\text{C}$ $I_T = 500 \text{ mA}$ Gate Open				100	mA
$I_L$	$T_j = 25 \text{ }^\circ\text{C}$ $V_D = 12 \text{ V}$ $I_G = 300 \text{ mA}$ Pulse Duration > 20 $\mu\text{s}$	I-III-IV		50		mA
		II		100		
$V_{TM}^*$	$T_j = 25 \text{ }^\circ\text{C}$ $I_{TM} = 35 \text{ A}$ $t_p = 10 \text{ ms}$				2	V
$I_{DRM}^*$	$T_j = 100 \text{ }^\circ\text{C}$ $V_{DRM}$ Specified				3	mA
$dv/dt^*$	$T_j = 100 \text{ }^\circ\text{C}$ Gate Open Linear Slope up to $V_D = 67 \text{ } \% V_{DRM}$		250			V/ $\mu\text{s}$
$(dv/dt)_c^*$	$T_C = 60 \text{ }^\circ\text{C}$ $V_D = V_{DRM}$ $I_T = 35 \text{ A}$ $(di/dt)_c = 11.2 \text{ A/ms}$		10			V/ $\mu\text{s}$
$t_{gt}$	$T_j = 25 \text{ }^\circ\text{C}$ $V_D = V_{DRM}$ $I_T = 35 \text{ A}$ $I_G = 200 \text{ mA}$ $di_G/dt = 2 \text{ A}/\mu\text{s}$	I-II-III-IV		3		$\mu\text{s}$

\* For either polarity of electrode A<sub>2</sub> voltage with reference to electrode A<sub>1</sub>.

**PACKAGE MECHANICAL DATA**

TO 48 Metal

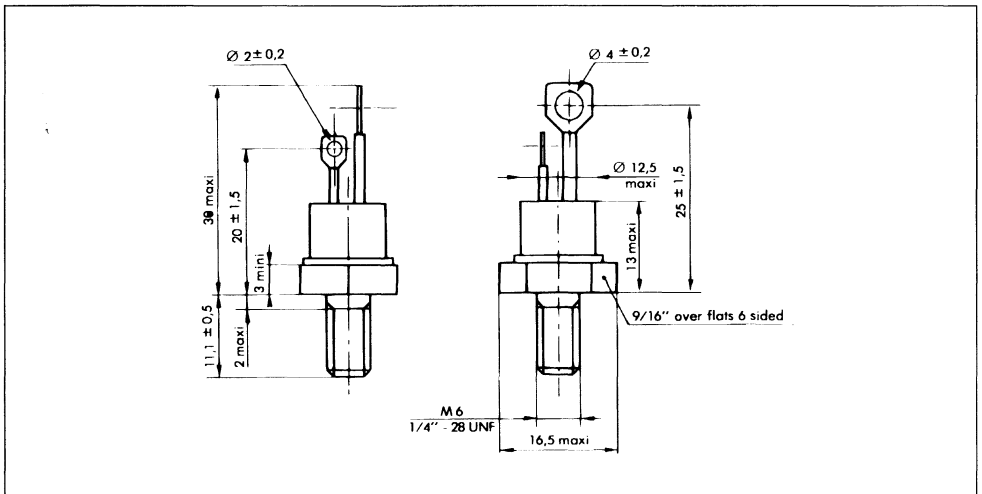

Cooling method : by conduction (method C)

Marking : type number

Weight :  $13.5 \pm 1 \text{ g}$

Polarity : anode to case

Stud torque :  $3.5 \text{ m}\cdot\text{N}$  min -  $3.8 \text{ m}\cdot\text{N}$  max.

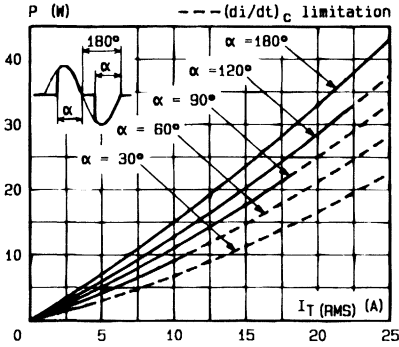

Fig. 1 - Maximum mean power dissipation versus RMS on-state current (F = 60 Hz).

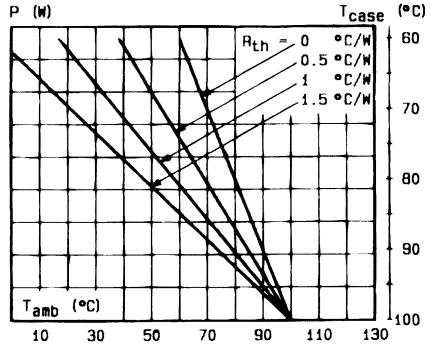

Fig. 2 - Correlation between maximum mean power dissipation and maximum allowable temperatures (T<sub>amb</sub> and T<sub>case</sub>) for different thermal resistances heatsink + contact.

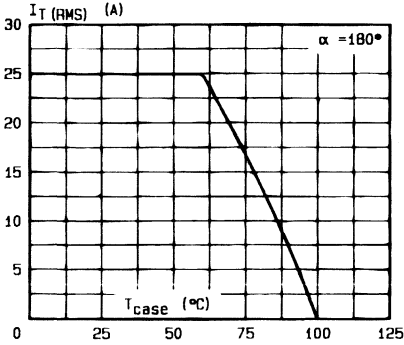

Fig. 3 - RMS on-state current versus case temperature.

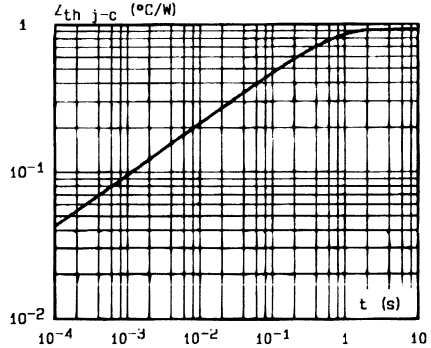

Fig. 4 - Thermal transient impedance junction to case versus pulse duration.

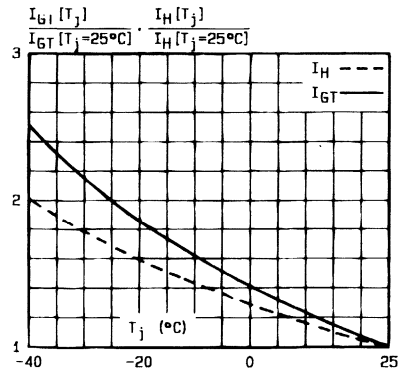

Fig. 5 - Relative variation of gate trigger current and holding current versus junction temperature.

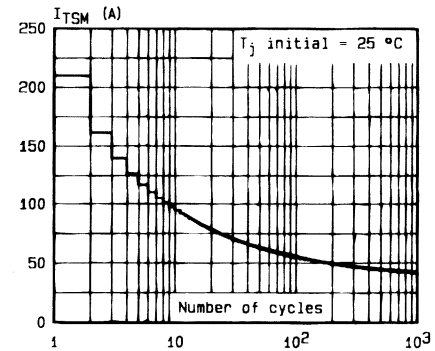

Fig. 6 - Non repetitive surge peak on-state current versus number of cycles.

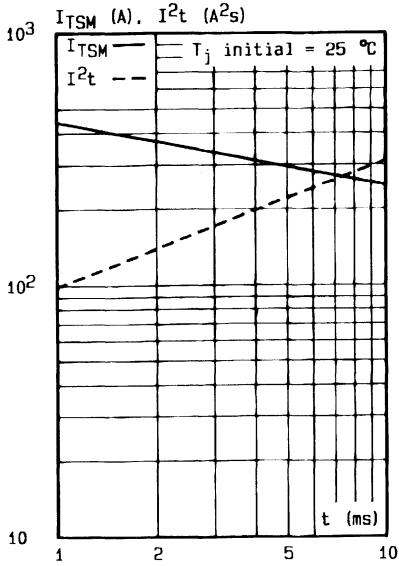

Fig.7 - Non repetitive surge peak on-state current for a sinusoidal pulse with width :  $t \leq 10$  ms, and corresponding value of  $I^2t$ .

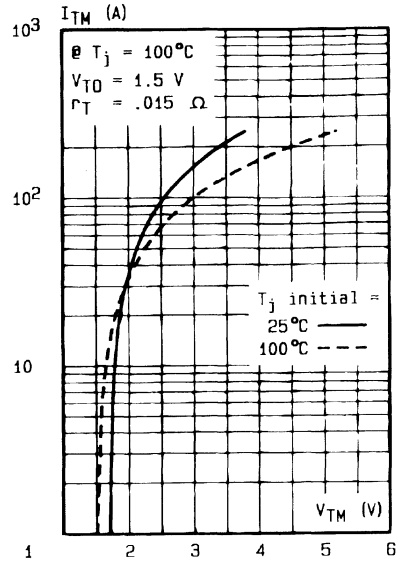

Fig.8 - On-state characteristics (maximum values).



**TRIACS**

- GLASS PASSIVATED CHIP
- $I_{GT}$  SPECIFIED IN FOUR QUADRANTS

**ADVANTAGES**

- EXCELLENT  $(dv/dt)_C : > 10 \text{ V}/\mu\text{s}$
- METALLIC ENCAPSULATION GIVES AN EXCELLENT THERMAL IMPEDANCE AND HIGH RELIABILITY CONSTRUCTION

**APPLICATIONS**

- MOTOR CONTROL
- HEATING CONTROL
- LIGHT DIMMER

**DESCRIPTION**

Power triacs suited for use on 220 V and 380 V main.

Thread : 1/4" -28 UNF : type N<sup>°</sup>  
M6 on request : type N<sup>°</sup> + suffix M

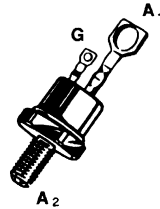

**TO 48**  
(Metal)

**ABSOLUTE RATINGS** (limiting values)

Symbol	Parameter	Value	Unit
$I_{T(RMS)}$	RMS on-state Current (360° conduction angle)	$T_C = 60 \text{ }^\circ\text{C}$ 35	A
$I_{TSM}$	Non Repetitive Surge Peak on-state Current ( $T_J$ initial = 25 °C - Half sine wave)	$t = 8.3 \text{ ms}$	330
		$t = 10 \text{ ms}$	300
$I^2t$	$I^2t$ Value for Fusing	$t = 10 \text{ ms}$ 450	A <sup>2</sup> s
$di/dt$	Critical Rate of Rise of on-state Current (1)	Repetitive $F = 50 \text{ Hz}$	20
		Non Repetitive	100
$T_{stg}$ $T_J$	Storage and Operating Junction Temperature Range	- 40 to 150	°C
		- 40 to 110	°C

Symbol	Parameter	TRAL				Unit
		1135D	2235D	3335D	3835D	
$V_{DRM}$	Repetitive Peak off-state Voltage (2)	200	400	600	700	V

(1)  $I_G = 1.5 \text{ A}$   $di/dt = 1 \text{ A}/\mu\text{s}$   
(2)  $T_J = 110 \text{ }^\circ\text{C}$ .

**THERMAL RESISTANCES**

Symbol	Parameter	Value	Unit
$R_{th(c-h)}$	Contact (case-heatsink) for Recommended Stud Torque	0.4	°C/W
$R_{th(j-c)} \text{ DC}$	Junction to Case for DC	1.12	°C/W
$R_{th(j-c)} \text{ AC}$	Junction to Case for 360 ° Conduction Angle ( $F = 50 \text{ Hz}$ )	0.84	°C/W

**GATE CHARACTERISTICS** (maximum values)

$P_{GM} = 40 \text{ W}$  ( $t_p = 10 \mu\text{s}$ )

$I_{GM} = 6 \text{ A}$  ( $t_p = 10 \mu\text{s}$ )

$P_{G(AV)} = 1 \text{ W}$

$V_{GM} = 16 \text{ V}$  ( $t_p = 10 \mu\text{s}$ )

**ELECTRICAL CHARACTERISTICS**

Symbol	Test Conditions			Quadrants	Min.	Typ.	Max.	Unit
$I_{GT}$	$T_j = 25 \text{ }^\circ\text{C}$ Pulse Duration > 20 $\mu\text{s}$	$V_D = 12 \text{ V}$	$R_L = 33 \text{ } \Omega$	I-II-III			100	mA
				IV			150	
$V_{GT}$	$T_j = 25 \text{ }^\circ\text{C}$ Pulse Duration > 20 $\mu\text{s}$	$V_D = 12 \text{ V}$	$R_L = 33 \text{ } \Omega$	I-II-III-IV			1.5	V
$V_{GD}$	$T_j = 110 \text{ }^\circ\text{C}$	$V_D = V_{DRM}$	$R_L = 3.3 \text{ k}\Omega$	I-II-III-IV	0.2			V
$I_{H^*}$	$T_j = 25 \text{ }^\circ\text{C}$	$I_T = 500 \text{ mA}$	Gate Open				100	mA
$I_L$	$T_j = 25 \text{ }^\circ\text{C}$ Pulse Duration > 20 $\mu\text{s}$	$V_D = 12 \text{ V}$	$I_G = 300 \text{ mA}$	I-III-IV		60		mA
				II		120		
$V_{TM}^*$	$T_j = 25 \text{ }^\circ\text{C}$	$I_{TM} = 53 \text{ A}$	$t_p = 10 \text{ ms}$				2	V
$I_{DRM}^*$	$T_j = 110 \text{ }^\circ\text{C}$	$V_{DRM}$ Specified					4	mA
$dv/dt^*$	$T_j = 110 \text{ }^\circ\text{C}$	Gate Open	Linear Slope up to $V_D = 67\% V_{DRM}$		250			V/ $\mu\text{s}$
$(dv/dt)_c^*$	$T_c = 60 \text{ }^\circ\text{C}$	$V_D = V_{DRM}$	$I_T = 53 \text{ A}$ $(di/dt)_c = 15.5 \text{ A/ms}$		10			V/ $\mu\text{s}$
$t_{gt}$	$T_j = 25 \text{ }^\circ\text{C}$	$V_D = V_{DRM}$	$I_T = 53 \text{ A}$ $I_G = 200 \text{ mA}$ $di_G/dt = 2 \text{ A}/\mu\text{s}$	I-II-III-IV		3		$\mu\text{s}$

\* For either polarity of electrode  $A_2$  voltage with reference to electrode  $A_1$ .

**PACKAGE MECHANICAL DATA**

TO 48 Metal

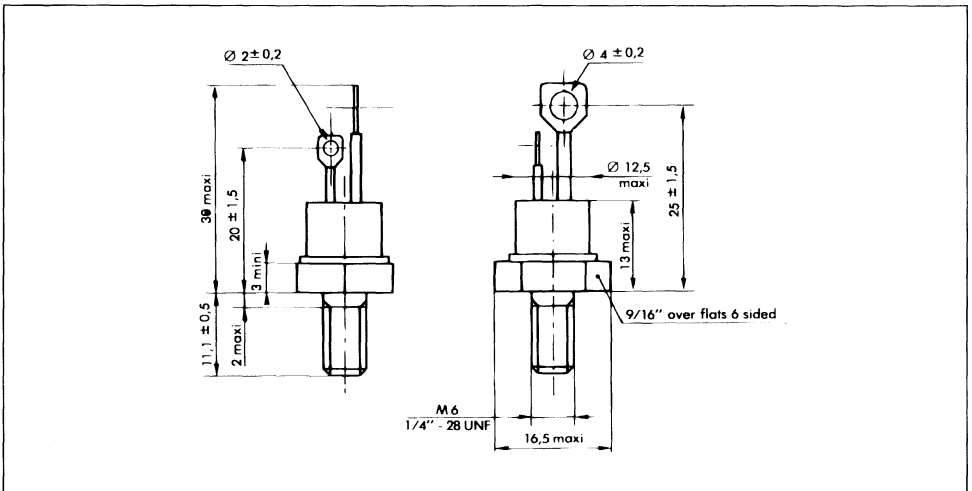

Cooling method : by conduction (method C)

Marking : type number

Weight :  $13.5 \pm 1 \text{ g}$

Polarity : anode to case

Stud torque :  $3.5 \text{ m}\Lambda\text{N min} - 3.8 \text{ m}\Lambda\text{N max}$ .

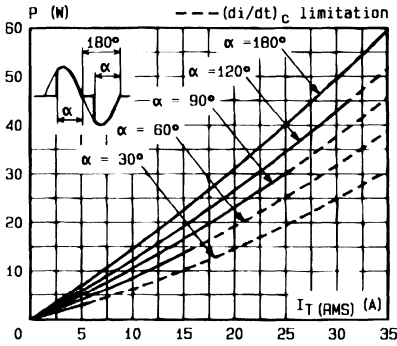

Fig. 1 - Maximum mean power dissipation versus RMS on-state current ( $f = 60$  Hz).

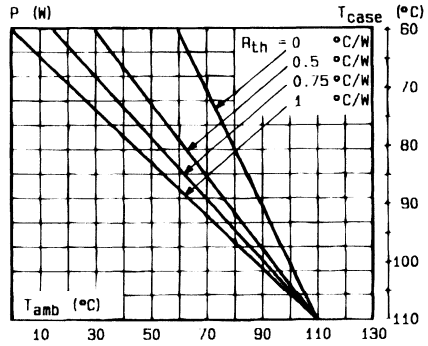

Fig. 2 - Correlation between maximum mean power dissipation and maximum allowable temperatures ( $T_{amb}$  and  $T_{case}$ ) for different thermal resistances heatsink + contact.

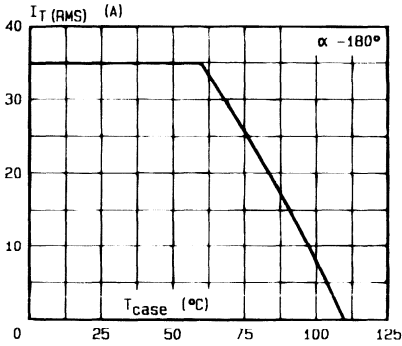

Fig. 3 - RMS on-state current versus case temperature.

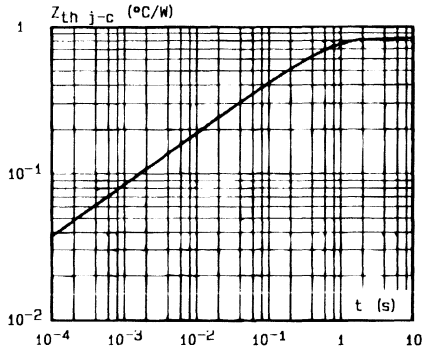

Fig. 4 - Thermal transient impedance to case versus pulse duration.

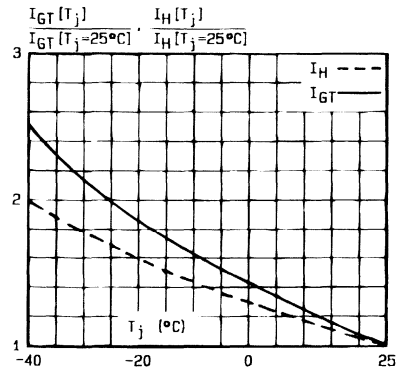

Fig. 5 - Relative variation of gate trigger current and holding current versus junction temperature.

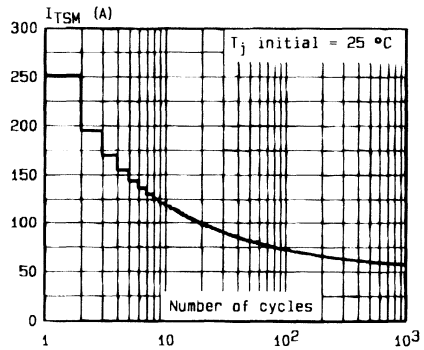

Fig. 6 - Non repetitive surge peak on-state current versus number of cycles.

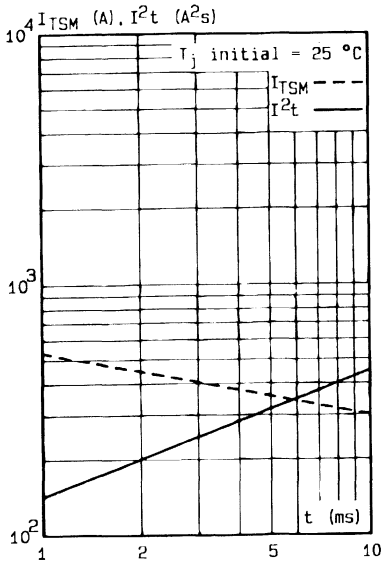

Fig.7 - Non repetitive surge peak on-state current for a sinusoidal pulse with width:  $t \leq 10$ ms, and corresponding value of  $I^2t$ .

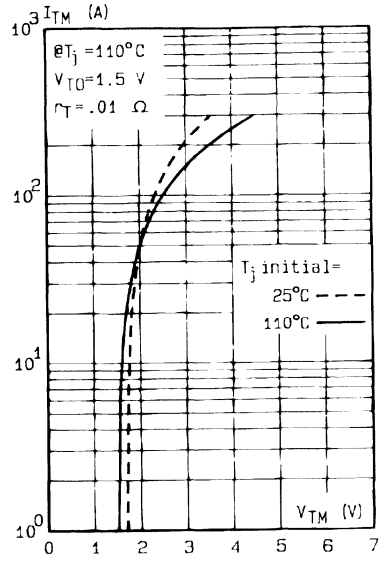

Fig.8 - On-state characteristic (maximum values).



**ALTERNISTORS**

- $(di/dt)_c > 28$  A/ms (400 Hz)
- INSULATING VOLTAGE : 2500 V<sub>RMS</sub>  
( $t \leq 1$  mn - F = 50 Hz)
- UL RECOGNIZED (E81734)

**APPLICATIONS**

- POWER CONTROL ON INDUCTIVE LOAD  
(motor, transformer...)
- HIGH FREQUENCY OR HIGH  $(di/dt)_c$  LEVEL  
CIRCUITS

**DESCRIPTION**

New range of solid state AC - switches with very high commutating capability.

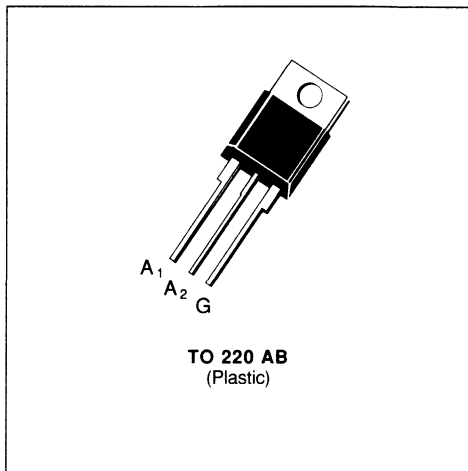
**ABSOLUTE RATINGS** (limiting values)

Symbol	Parameter		Value	Unit	
$I_{T(RMS)}$	RMS on-state Current (360° conduction angle)		$T_C = 75^\circ C$ 8	A	
$I_{TSM}$	Non Repetitive Surge Peak on-state Current		$t = 10$ ms	80	A
			$t = 8.3$ ms	85	
			$t = 2.5$ ms	115	
$I^2t$	$I^2t$ Value for Fusing	$t = 10$ ms	32	A <sup>2</sup> s	
$di/dt$	Critical Rate of Rise of on-state Current (1)		100	A/ $\mu$ s	
$T_{stg}$ $T_j$	Storage and Operating Junction Temperature Range		- 40 to 150	$^\circ C$	
			- 40 to 110	$^\circ C$	

Symbol	Parameter	TXDV				Unit
		208	408	608	808	
$V_{DRM}$	Repetitive Peak off-state Voltage (2)	200	400	600	800	V

(1)  $I_G = 1$  A  $di_G/dt = 1$  A/ $\mu$ s

(2)  $T_j = 110^\circ C$ .

**THERMAL RESISTANCES**

Symbol	Parameter	Value	Unit
$R_{th(j-a)}$	Junction to Ambient	60	$^\circ C/W$
$R_{th(j-c)} DC$	Junction to Case for DC	4	$^\circ C/W$
$R_{th(j-c)} AC$	Junction to Case for 360° Conduction Angle (F = 50 Hz)	3	$^\circ C/W$

**GATE CHARACTERISTICS** (maximum values)

$P_{GM} = 40 \text{ W}$  ( $t_p = 10 \mu\text{s}$ )       $I_{GM} = 4 \text{ A}$  ( $t_p = 10 \mu\text{s}$ )  
 $P_{G(AV)} = 1 \text{ W}$        $V_{GM} = 16 \text{ V}$  ( $t_p = 10 \mu\text{s}$ )

**ELECTRICAL CHARACTERISTICS**

Symbol	Test Conditions	Quadrants	Min.	Typ.	Max.	Unit
$I_{GT}$	$T_J = 25 \text{ }^\circ\text{C}$ $V_D = 12 \text{ V}$ $R_L = 33 \text{ } \Omega$ Pulse Duration > 20 $\mu\text{s}$	I-II-III			100	mA
$V_{GT}$	$T_J = 25 \text{ }^\circ\text{C}$ $V_D = 12 \text{ V}$ $R_L = 33 \text{ } \Omega$ Pulse Duration > 20 $\mu\text{s}$	I-II-III			1.5	V
$V_{GD}$	$T_J = 110 \text{ }^\circ\text{C}$ $V_D = V_{DRM}$ $R_L = 3.3 \text{ k}\Omega$	I-II-III	0.2			V
$I_H^*$	$T_J = 25 \text{ }^\circ\text{C}$ $I_T = 500 \text{ mA}$ Gate Open				100	mA
$I_L$	$T_J = 25 \text{ }^\circ\text{C}$ $V_D = 12 \text{ V}$ $I_G = 200 \text{ mA}$ Pulse Duration > 20 $\mu\text{s}$	I-III		100		mA
		II		200		
$V_{TM}^*$	$T_J = 25 \text{ }^\circ\text{C}$ $I_{TM} = 11 \text{ A}$ $t_p = 10 \text{ ms}$				1.8	V
$I_{DRM}^*$	$T_J = 110 \text{ }^\circ\text{C}$ $V_{DRM}$ Specified				2	mA
$dv/dt^*$	$T_J = 110 \text{ }^\circ\text{C}$ Gate Open Linear Slope up to $V_D = 67 \% V_{DRM}$		500			V/ $\mu\text{s}$
$(di/dt)_c^*$	$T_C = 75 \text{ }^\circ\text{C}$ $V_D = V_{DRM}$ $I_T = 11 \text{ A}$	$(dv/dt)_c = 200 \text{ V}/\mu\text{s}$	7			A/ms
		$(dv/dt)_c = 10 \text{ V}/\mu\text{s}$	28			
$t_{gt}$	$T_J = 25 \text{ }^\circ\text{C}$ $V_D = V_{DRM}$ $I_T = 11 \text{ A}$ $I_G = 0.5 \text{ A}$ $di_G/dt = 3.5 \text{ A}/\mu\text{s}$	I-II-III		2.5		$\mu\text{s}$

\* For either polarity of electrode  $A_2$  voltage with reference to electrode  $A_1$ .

**PACKAGE MECHANICAL DATA : TO 220 AB Plastic**

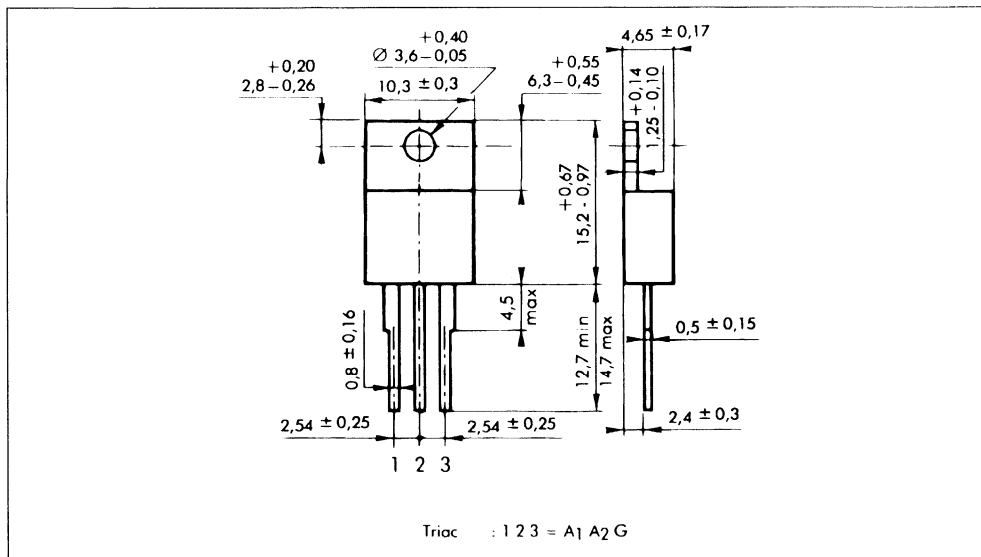

Cooling method : by conduction (method C)  
 Marking : type number  
 Weight : 2 g

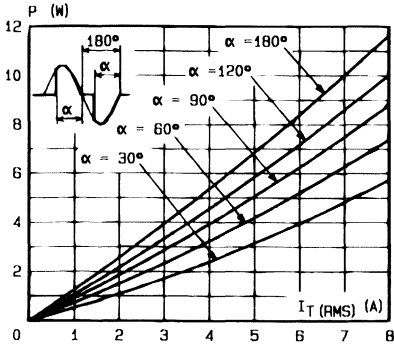

Fig.1 - Maximum mean power dissipation versus RMS on-state current.

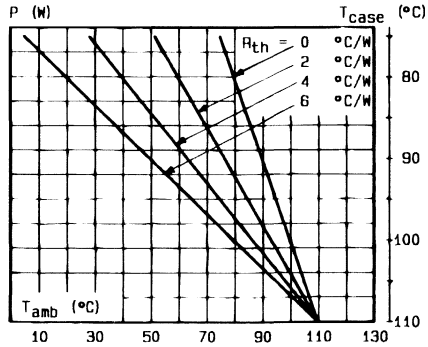

Fig.2 - Correlation between maximum mean power dissipation and maximum allowable temperatures ( $T_{amb}$  and  $T_{case}$ ) for different thermal resistances heatsink + contact.

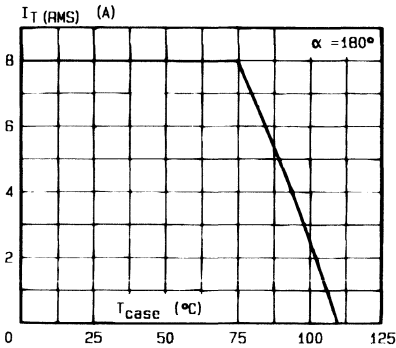

Fig.3 - RMS on-state current versus case temperature.

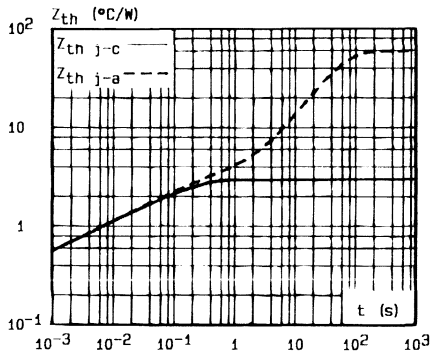

Fig.4 - Thermal transient impedance junction to case and junction to ambient versus pulse duration.

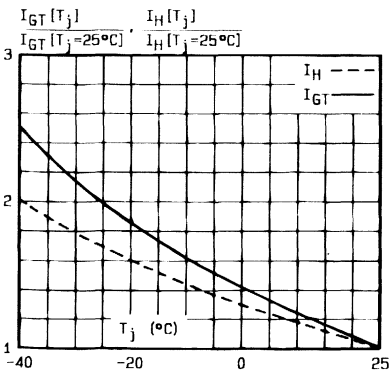

Fig.5 - Relative variation of gate trigger current and holding current versus junction temperature.

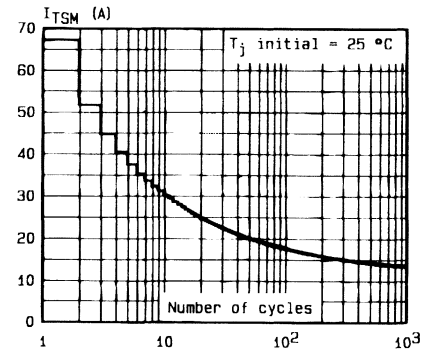

Fig.6 - Non repetitive surge peak on-state current versus number of cycles.

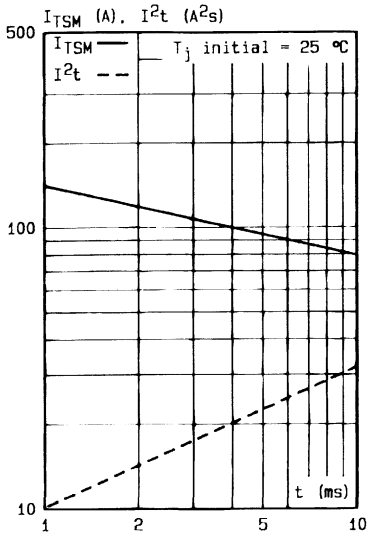

Fig.7 - Non repetitive surge peak on-state current for a sinusoidal pulse with width :  $t \leq 10$  ms, and corresponding value of  $I^2t$ .

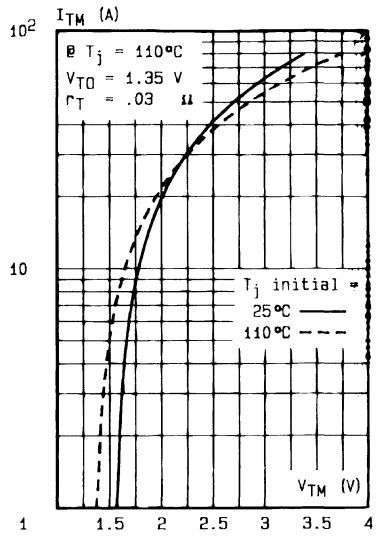

Fig.8 - On-state characteristics (maximum values).

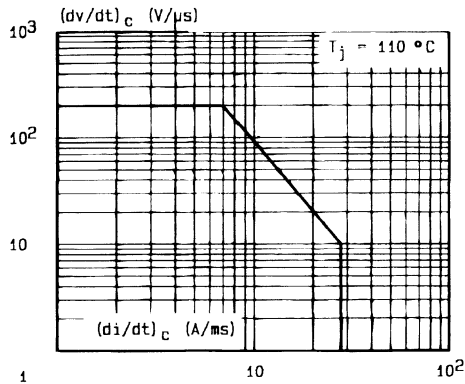

Fig.9 - Safe operating area.

**ALTERNISTORS**

- $(di/dt)_c > 42.5$  A/ms (400 Hz)
- INSULATING VOLTAGE : 2500 V<sub>RMS</sub>  
( $t \leq 1$  mn - F = 50 Hz)
- UL RECOGNIZED (E81734)

**APPLICATIONS**

- POWER CONTROL ON INDUCTIVE LOAD  
(motor, transformer...)
- HIGH FREQUENCY OR HIGH  $(di/dt)_c$  LEVEL  
CIRCUITS

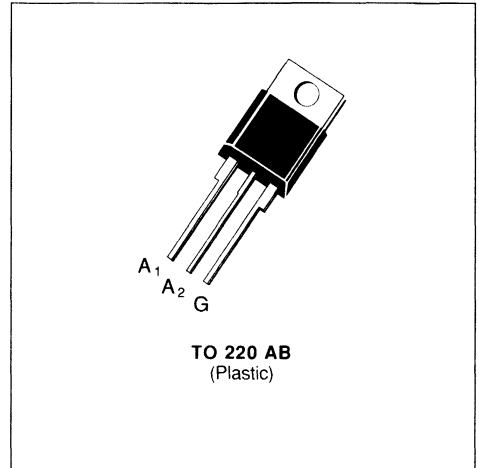
**DESCRIPTION**

New range of solid state AC - switches with very high commutating capability.

**ABSOLUTE RATINGS** (limiting values)

Symbol	Parameter		Value	Unit
$I_{T(RMS)}$	RMS on-state Current (360° conduction angle)	$T_C = 75$ °C	12	A
$I_{TSM}$	Non Repetitive Surge Peak on-state Current	$t = 10$ ms	120	A
		$t = 8.3$ ms	125	
		$t = 2.5$ ms	170	
$I^2t$	$I^2t$ Value for Fusing	$t = 10$ ms	72	A <sup>2</sup> s
$di/dt$	Critical Rate of Rise of on-state Current (1)		100	A/ $\mu$ s
$T_{stg}$ $T_J$	Storage and Operating Junction Temperature Range		- 40 to 150	°C
			- 40 to 110	°C

Symbol	Parameter	TXDV				Unit
		212	412	612	812	
$V_{DRM}$	Repetitive Peak off-state Voltage (2)	200	400	600	800	V

(1)  $I_G = 1$  A  $di_G/dt = 1$  A/ $\mu$ s

(2)  $T_J = 110$  °C.

**THERMAL RESISTANCES**

Symbol	Parameter	Value	Unit
$R_{th(j-a)}$	Junction to Ambient	60	°C/W
$R_{th(j-c)} DC$	Junction to Case for DC	2.5	°C/W
$R_{th(j-c)} AC$	Junction to Case for 360° Conduction Angle (F = 50 Hz)	1.85	°C/W

**GATE CHARACTERISTICS** (maximum values)

$P_{GM} = 40 \text{ W}$  ( $t_p = 10 \mu\text{s}$ )       $I_{GM} = 4 \text{ A}$  ( $t_p = 10 \mu\text{s}$ )  
 $P_{G(AV)} = 1 \text{ W}$        $V_{GM} = 16 \text{ V}$  ( $t_p = 10 \mu\text{s}$ )

**ELECTRICAL CHARACTERISTICS**

Symbol	Test Conditions			Quadrants	Min.	Typ.	Max.	Unit
$I_{GT}$	$T_j = 25 \text{ }^\circ\text{C}$	$V_D = 12 \text{ V}$	$R_L = 33 \text{ } \Omega$	I-II-III			100	mA
	Pulse Duration > 20 $\mu\text{s}$							
$V_{GT}$	$T_j = 25 \text{ }^\circ\text{C}$	$V_D = 12 \text{ V}$	$R_L = 33 \text{ } \Omega$	I-II-III			1.5	V
	Pulse Duration > 20 $\mu\text{s}$							
$V_{GD}$	$T_j = 110 \text{ }^\circ\text{C}$	$V_D = V_{DRM}$	$R_L = 3.3 \text{ k}\Omega$	I-II-III	0.2			V
$I_H^*$	$T_j = 25 \text{ }^\circ\text{C}$	$I_T = 500 \text{ mA}$	Gate Open				100	mA
$I_L$	$T_j = 25 \text{ }^\circ\text{C}$	$V_D = 12 \text{ V}$	$I_G = 200 \text{ mA}$	I-III		100		mA
	Pulse Duration > 20 $\mu\text{s}$			II		200		
$V_{TM}^*$	$T_j = 25 \text{ }^\circ\text{C}$	$I_{TM} = 17 \text{ A}$	$t_p = 10 \text{ ms}$				1.95	V
$I_{DRM}^*$	$T_j = 110 \text{ }^\circ\text{C}$	$V_{DRM}$ Specified					2	mA
$dv/dt^*$	$T_j = 110 \text{ }^\circ\text{C}$	Gate Open			500			V/ $\mu\text{s}$
	Linear Slope up to $V_D = 67 \% V_{DRM}$							
$(di/dt)_c^*$	$T_C = 75 \text{ }^\circ\text{C}$	$V_D = V_{DRM}$	$(dv/dt)_c = 200 \text{ V}/\mu\text{s}$		10			A/ms
			$I_T = 17 \text{ A}$	$(dv/dt)_c = 10 \text{ V}/\mu\text{s}$		42.5		
$t_{gt}$	$T_j = 25 \text{ }^\circ\text{C}$	$V_D = V_{DRM}$	$I_T = 17 \text{ A}$	I-II-III		2.5		$\mu\text{s}$
	$I_G = 0.5 \text{ A}$ $di_G/dt = 3.5 \text{ A}/\mu\text{s}$							

\* For either polarity of electrode A<sub>2</sub> voltage with reference to electrode A<sub>1</sub>.

**PACKAGE MECHANICAL DATA : TO 220 AB Plastic**

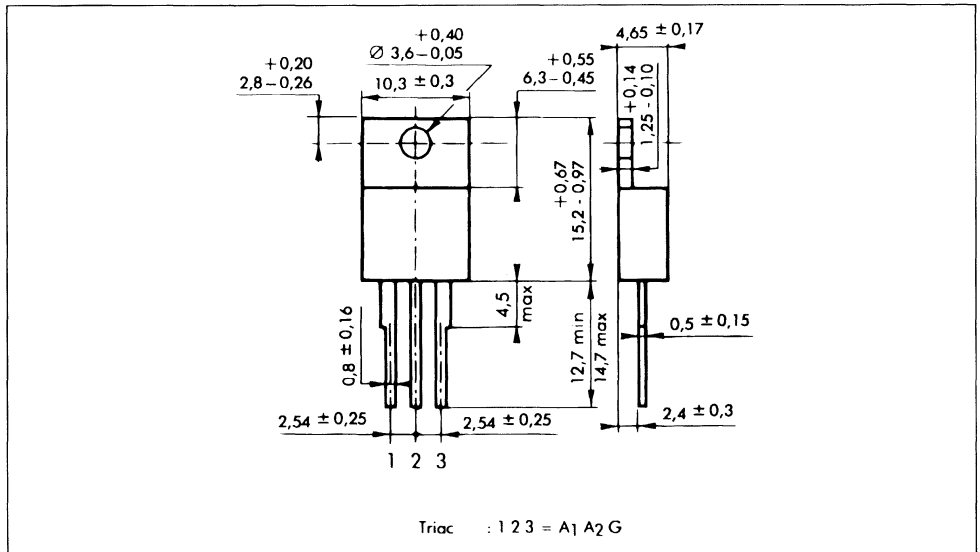

Cooling method : by conduction (method C)

Marking : type number

Weight : 2 g

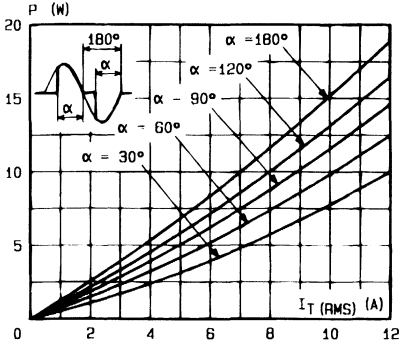

Fig. 1 - Maximum mean power dissipation versus RMS on-state current

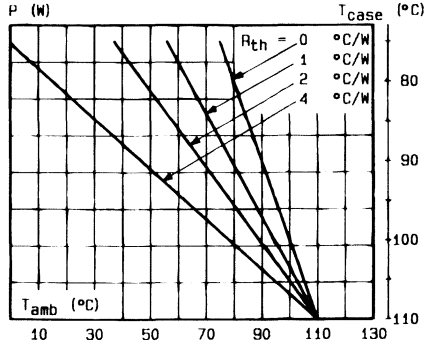

Fig. 2 - Correlation between maximum mean power dissipation and maximum allowable temperatures ( $T_{amb}$  and  $T_{case}$ ) for different thermal resistances heatsink + contact.

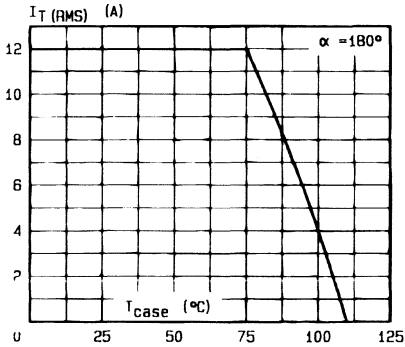

Fig. 3 - RMS on-state current versus case temperature.

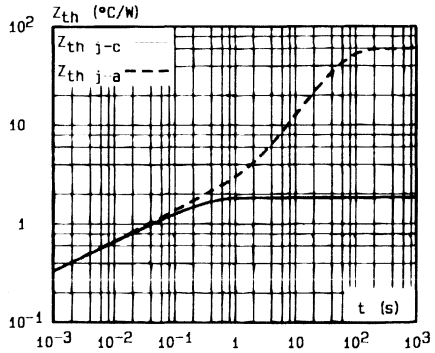

Fig. 4 - Thermal transient impedance junction to case and junction to ambient versus pulse duration.

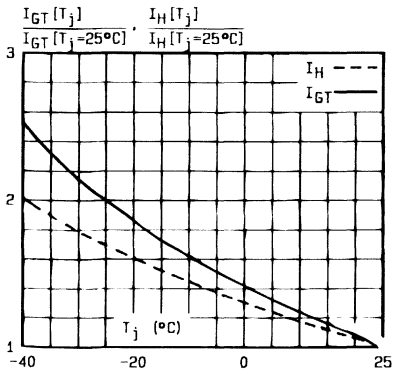

Fig. 5 - Relative variation of gate trigger current and holding current versus junction temperature.

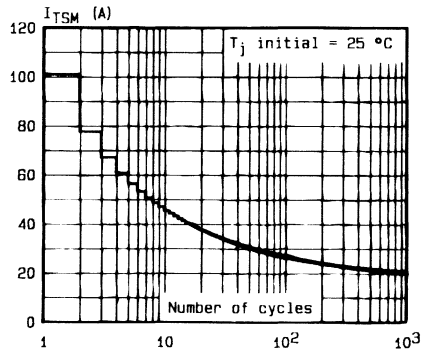

Fig. 6 - Non repetitive surge peak on-state current versus number of cycles.

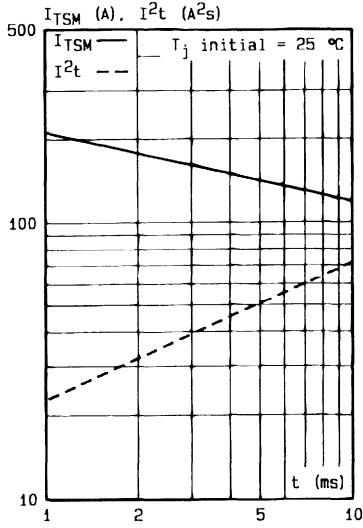

Fig.7 - Non repetitive surge peak on-state current for a sinusoidal pulse with width :  $t \leq 10$  ms, and corresponding value of  $I^2t$ .

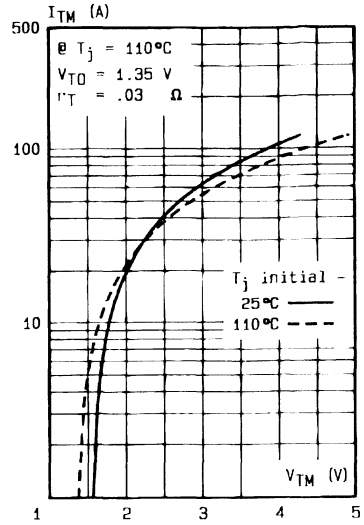

Fig.8 - On-state characteristics (maximum values).

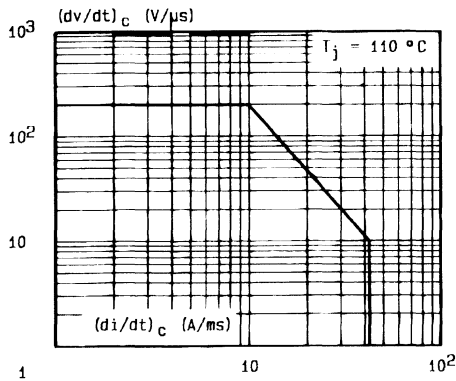

Fig.9 - Safe operating area.





## NOTES



## AUSTRALIA

### NSW 2027 EDGECLIFF

Suite 211, Edgecliff centre  
203-233, New South Head Road  
Tel. (61-2) 327-39-22  
Telex: 071 126911 TCAUS  
Telefax: (61-2) 327.61.76

## BRAZIL

### 05413 SÃO PAULO

R. Henrique Schaumann 286-CJ33  
Tel. (55-11) 883-5455  
Telex: (39-11) 37988 "UMBR BR"

## CANADA

### BRAMPTON, ONTARIO

341 Main St. North  
Tel. (416) 455-0505  
Telefax: 416-455-2606

## CHINA

### BEIJING

Beijing No. 5 Semiconductor  
Device Factory  
14 Wu Lu Tong Road  
Da Shang Mau Wai  
Tel. (86-1) 2024378  
Telex 222722 STM CH

## DENMARK

### 2730 HERLEV

Herlev Torv, 4  
Tel. (45-2) 94.85.33  
Telex: 35411  
Telefax: (45-2) 948694

## FRANCE

### 94253 GENTILLY Cedex

7 - avenue Gallieni - BP. 93  
Tel.: (33-1) 47.40.75.75  
Telex: 632570 STMHQ  
Telefax: (33-1) 47.40.79.10

### 67000 STRASBOURG

20, Place des Halles  
Tel. (33) 88.25.49.90  
Telex: 870001F  
Telefax: (33) 88.22.29.32

## HONG KONG

### WANCHAI

22nd Floor - Hopewell centre  
183 Queen's Road East  
Tel. (852-5) 8615788  
Telex: 60955 ESGIES HX  
Telefax: (852-5) 8656589

## INDIA

### NEW DELHI 110048

Liason Office  
S114, Greater Kailash Part 2  
Tel. (91) 6414537  
Telex: 31-62000 SGSS IN

## ITALY

### 20090 ASSAGO (MI)

V.le Milanofiori - Strada 4 - Palazzo A/4/A  
Tel. (39-6) 89213.1 (10 linee)  
Telex: 330131 - 330141 SGSAGR  
Telefax: (39-2) 8250449

### 40033 CASALECCHIO DI RENO (BO)

Via R. Fucini, 12  
Tel. (39-51) 591914  
Telex: 512442  
Telefax: (39-51) 591305

### 00161 ROMA

Via A. Torlonia, 15  
Tel. (39-6) 8443341/2/3/4/5  
Telex: 620653 SGSATE I  
Telefax: (39-6) 8444474

## JAPAN

### TOKYO 141

Shinagawa-Ku, Nishi Gotanda  
8-11-7, Collins Bldg 8  
Tel. (81-3) 491-8611  
Telefax: (81-3) 491-8735

## KOREA

### SEOUL 121

8th floor Shinwon Building  
823-14, Yuksam-Dong  
Kang-Nam-Gu  
Tel. (82-2) 552-0399  
Telex: SGSKOR K29998  
Telefax: (82-2) 552-1051

## NETHERLANDS

### 5612 AM EINDHOVEN

Dillenburgstraat 25  
Tel.: (31-40) 550015  
Telex: 51186  
Telefax: (31-40) 528835

## SINGAPORE

### SINGAPORE 2056

28 Ang Mo Kio - Industrial Park 2  
Tel. (65) 4821411  
Telex: RS 55201 ESGIES  
Telefax: (65) 4820240

## SPAIN

### 08021 BARCELONA

Calle Platon, 6 4<sup>th</sup> Floor, 5<sup>th</sup> Door  
Tel. (34-3) 2022017-2020316  
Telefax: (34-3) 2021461

### 28027 MADRID

Calle Albacete, 5  
Tel. (34-1) 4051615  
Telex: 27060 TCEE  
Telefax: (34-1) 4031134

## SWEDEN

### S-16421 KISTA

Borgarfjordsgatan, 13 - Box 1094  
Tel.: (46-8) 7939220  
Telex: 12078 THSWS  
Telefax: (46-8) 7504950

## SWITZERLAND

### 1218 GRAND-SACONNEX (GENÈVE)

Chemin François-Lehmann, 18/A  
Tel. (41-22) 7986462  
Telex: 415493 STM CH  
Telefax: (41-22) 7984869

## TAIWAN

### KAOHSIUNG

7FL-2 No  
5 Chung Chen 3rd Road  
Tel. (886-7) 2011702  
Telefax: (886-7) 2011703

### TAIPEI

6th Floor, Pacific Commercial Building  
285 Chung Hsiao E. Road - SEC. 4  
Tel. (886-2) 7728203  
Telex: 10310 ESGIE TW  
Telefax: (886-2) 7413837

## UNITED KINGDOM

### MARLOW, BUCKS

Planar House, Parkway  
Globe Park  
Tel.: (44-628) 890800  
Telex: 847458  
Telefax: (44-628) 890391

## U.S.A.

NORTH & SOUTH AMERICAN  
MARKETING HEADQUARTERS  
1000 East Bell Road  
Phoenix, AZ 85022  
(1)(602) 867 6100

## SALES COVERAGE BY STATE

### AL

Huntsville - (205) 533-5995

### AZ

Phoenix - (602) 867-6340

### CA

Irvine - (714) 250-0455  
San José - (408) 452-8585

### CO

Boulder (303) 449-9000

### IL

Schaumburg - (312) 517-1890

### IN

Kokomo - (317) 459-4700

### MA

Waltham - (617) 890-6688

### MI

Southfield - (313) 358-4250

### NC

Raleigh - (919) 832-7775

### NJ

Voorhees - (609) 772-6222

### NY

Poughkeepsie - (914) 454-8813

### OR

Tigard - (503) 620-5517

### TX

Austin - (512) 339-4191  
Carrollton - (214) 466-8844

### WA

Seattle - (206) 524-6421

FOR RF AND MICROWAVE  
POWER TRANSISTORS CONTACT  
THE FOLLOWING REGIONAL  
OFFICES IN THE U.S.A.

### CA

Hawthorne - (213) 675-0742

### NJ

Totowa - (201) 890-0884

### PA

Montgomeryville - (215) 362-8500

### TX

Carrollton - (214) 466-8844

## WEST GERMANY

### 6000 FRANKFURT M1

Gutleutstraße 322  
Tel. (49-69) 237492  
Telex: 176997 689  
Telefax: (49-69) 231957  
Teletex: 6997689 = STVBP

### 8011 GRASBRUNN

Bretonischer Ring 4  
Neukeferloh Technopark  
Tel. (49-89) 460060  
Telex: 528211  
Telefax: (49-89) 4605454  
Teletex: 897107 = STDISTR

### 3000 HANNOVER 1

Eckenerstraße 5  
Tel. (49-511) 634191  
Telex: 175118418  
Teletex: 5118418 cstbeh  
Telefax: (49-511) 633552

### 8500 NÜRNBERG 20

Erlenstegenstraße, 72  
Tel. (49-911) 597032  
Telex: 626243  
Telefax: (49-911) 5980701

### 5200 SIEGBURG

Frankfurter Str. 22a  
Tel. (49-2241) 660 84-86  
Telex: 889510  
Telefax: (49-2241) 67584

### 7000 STUTTGART 1

Oberer Kirchhaldenweg 135  
Tel. (49-711) 692041  
Telex: 721718  
Telefax: (49-711) 691408

Information furnished is believed to be accurate and reliable. However, SGS-THOMSON Microelectronics assumes no responsibility for the consequences of use of such information nor for any infringement of patents or other rights of third parties which may result from its use. No license is granted by implication or otherwise under any patent or patent rights of SGS-THOMSON Microelectronics. Specifications mentioned in this publication are subject to change without notice. This publication supersedes and replaces all information previously supplied. SGS-THOMSON Microelectronics products are not authorized for use as critical components in life support devices or systems without express written approval of SGS-THOMSON Microelectronics.

Cover design by Keith & Koppel, Segrate, Italy  
Type setting and layout on Desk Top Publishing  
by AZIMUT, Hénin Bt., France  
Printed by Garzanti, Cernusco S/N, Italy

© 1989 SGS-THOMSON Microelectronics — All Rights Reserved

SGS-THOMSON Microelectronics GROUP OF COMPANIES

Australia · Brazil · China · France · Hong Kong · Italy · Japan · Korea · Malaysia · Malta · Morocco · The Netherlands ·  
Singapore · Spain · Sweden · Switzerland · Taiwan · United Kingdom · U.S.A. · West Germany